

# Contents

<b>MOTORCYCLE SAFETY..... 1</b>	<b>SERVICING YOUR HONDA .....21</b>	<u>Chassis</u>
Important Safety Information ..... 2	<i>Before You Service Your Honda</i>	Suspension ..... 97
Important Safety Precautions ..... 2	The Importance of Maintenance ..... 22	Brakes ..... 114
Accessories & Modifications ..... 3	Maintenance Safety ..... 23	Wheels ..... 118
Safety Labels ..... 4	Important Safety Precautions ..... 23	Tires & Tubes ..... 119
<b>INSTRUMENTS &amp; CONTROLS..... 5</b>	Maintenance Schedule ..... 24	Side Stand (CRF450RX) ..... 121
Operation Component Locations ..... 6	Maintenance Schedule (CRF450RX) ..... 25	Drive Chain ..... 122
MIL (Malfunction Indicator Lamp) ..... 7	Maintenance Schedule (CRF450R/RWE) ..... 26	Exhaust Pipe/Muffler ..... 126
MIL Blink Pattern ..... 7	General Competition Maintenance ..... 27	Additional Maintenance Procedures ..... 132
Current DTC/Freeze DTC ..... 7	Before & After Competition Maintenance ..... 31	<u>Electrical</u>
Circuit Inspection ..... 8	Between Races (CRF450RX)/Motos	Battery ..... 134
DTC Index ..... 9	(CRF450R/RWE) & Practice Maintenance ... 31	Appearance Care ..... 136
Engine Mode & Launch Control System Indicator	After Competition Maintenance ..... 32	
& Torque Control Indicator ..... 10	<i>Service Preparations</i>	
Engine Mode Indicator ..... 10	Maintenance Component Locations ..... 33	
Launch Control System Indicator ..... 10	Seat ..... 34	
Torque Control Indicator ..... 10	Fuel Tank (CRF450RX) ..... 35	
<b>BEFORE RIDING..... 11</b>	Fuel Tank (CRF450R/RWE) ..... 37	
Are You Ready to Ride? ..... 12	Subframe ..... 39	
Is Your Motorcycle Ready to Ride? ..... 13	<i>Service Procedures</i>	
Pre-ride Inspection ..... 13	<u>Fluids &amp; Filters</u>	
<b>BASIC OPERATING INSTRUCTIONS .... 15</b>	Fuel System (CRF450RX) ..... 42	
Safe Riding Precautions ..... 16	Fuel System (CRF450R/RWE) ..... 52	
Side Stand (CRF450RX) ..... 16	Engine Oil ..... 62	
Honda Selectable Torque Control ..... 16	Coolant ..... 65	
Starting & Stopping the Engine ..... 17	Air Cleaner ..... 67	
Fast Idle Knob ..... 17	Crankcase Breather ..... 69	
Preparation ..... 17	<u>Engine</u>	
Starting Procedure ..... 17	Throttle ..... 70	
How to Stop the Engine ..... 18	Engine Idle Speed ..... 72	
Parking (CRF450RX) ..... 19	Clutch System ..... 73	
Break-in Guidelines ..... 20	Spark Plug ..... 78	
	Valve Clearance ..... 79	
	Piston/Piston Rings/Piston Pin ..... 88	

<b>ADJUSTMENTS FOR COMPETITION... 139</b>	<b>TIPS..... 161</b>	<b>INDEX ..... 190</b>
Engine Mode Select Button ..... 140	Transporting Your Motorcycle ..... 162	<b>QUICK REFERENCE</b>
Current Mode ..... 140	Storing Your Honda ..... 163	
Mode Selection..... 140	Preparation for Storage ..... 163	
Honda Selectable Torque Control ..... 141	Removal from Storage ..... 163	
Current Mode ..... 141	You & the Environment ..... 164	
Mode Selection..... 141	Troubleshooting ..... 165	
HRC-Launch Control System ..... 142		
Front Suspension Adjustments ..... 143	<b>TAKING CARE OF THE</b>	
Front Suspension Air Pressure ..... 143	<b>UNEXPECTED ..... 167</b>	
Front Suspension Damping ..... 144	If a Fuse Blows ..... 168	
Fork Springs ..... 144	If Your Battery Is Low (or Dead) ..... 169	
Fork Oil Adjustment..... 145		
Rear Suspension Adjustments ..... 146	<b>TECHNICAL INFORMATION..... 171</b>	
Rear Suspension Spring Pre-Load..... 146	Vehicle Identification ..... 172	
Rear Suspension Damping ..... 147	Serial Numbers ..... 172	
Rear Suspension Race Sag ..... 149	Specifications ..... 173	
Suspension Adjustments for Track	Torque Specifications ..... 175	
Conditions ..... 151	Nuts, Bolts, Fasteners ..... 175	
Suspension Adjustment Guidelines ..... 152	Oxygenated Fuels ..... 178	
Tuning Tips ..... 155	Competition Logbook ..... 179	
Spark Plug Reading ..... 155	Optional Parts List ..... 181	
Chassis Adjustments ..... 156	Spare Parts & Equipment ..... 182	
Rear End..... 156	Spare Parts ..... 182	
Fork Height/Angle..... 156	General Tools..... 182	
Wheelbase ..... 156	Honda Special Tools ..... 182	
Gearing ..... 157	Chemical Products ..... 182	
Tire Selection for Track Conditions ..... 158	Other Products ..... 182	
Personal Fit Adjustments ..... 159	Wiring Diagram ..... 183	
Control Positioning ..... 159		
Handlebar Position, Width & Shape ..... 159	<b>CONSUMER INFORMATION ..... 185</b>	
	Authorized Manuals ..... 186	
	Contacting Honda ..... 187	
	Your Honda Dealer ..... 188	

**2020  
Honda CRF450RX/CRF450R/CRF450RWE  
OWNER'S MANUAL & COMPETITION HANDBOOK**



# Introduction

Congratulations on choosing your Honda CRF off-road racing (CRF450RX)/motocross (CRF450R/RWE), motorcycle.

When you own a Honda, you're part of a worldwide family of satisfied customers – people who appreciate Honda's reputation for building quality into every product.

Your CRF is a high performance racing motorcycle that utilizes the latest off-road racing (CRF450RX)/motocross (CRF450R/RWE) technology and is intended for competition use in sanctioned, closed-course events by experienced riders only.

Be aware that off-road racing (CRF450RX)/motocross (CRF450R/RWE) is a physically demanding sport that requires more than just a fine motorcycle. To do well, you must be in excellent physical condition and be a skillful rider. For the best results, work diligently on your physical conditioning and practice frequently.

Before riding, take time to get acquainted with your CRF and how it works. To protect your investment, we urge you to take responsibility for keeping your CRF well maintained. Scheduled service is a must, of course. But it's just as important to observe the break-in guidelines, and perform all the pre-ride and other periodic checks detailed in this manual.

You should also read the owner's manual before you ride. It's full of facts, instructions, safety information, and helpful tips. To make it easy to use, the manual contains a table of contents, a detailed list of topics at the beginning of each section, and an index at the back of the book.

As you read this manual, you will find information that is preceded by a **NOTICE** symbol. This information is intended to help you avoid damage to your CRF, other property, or the environment.

Unless you are mechanically qualified and have the proper tools, you should see your dealer for the service and adjustment procedures discussed in this manual.

An official Honda Service Manual for your CRF is available (page 186). It is the same manual your dealer uses. If you plan to do any service on your CRF beyond the standard maintenance procedures in this manual, you will find an official Honda Service Manual a valuable reference.

If you have any questions, or if you ever need a special service or repairs, remember that your Honda dealer knows your CRF best and is dedicated to your complete satisfaction.

Please report any change of address or ownership to your dealer so we will be able to contact you concerning important product information.

You may also want to visit our website at USA: [www.powersports.honda.com](http://www.powersports.honda.com).  
Canada: [www.honda.ca](http://www.honda.ca).

Happy riding!

## ABBREVIATION

Throughout this manual, the following abbreviations are used to identify the respective parts or system.

Abbrev. term	Full term
CKP sensor	Crankshaft Position sensor
DLC	Data Link Connector
DTC	Diagnostic Trouble Code
ECM	Engine Control Module
ECT sensor	Engine Coolant Temperature sensor
GP sensor	Gear Position sensor
IAT sensor	Intake Air Temperature sensor
MAP sensor	Manifold Absolute Pressure sensor
MIL	Malfunction Indicator Lamp
PGM-FI	Programmed Fuel Injection
TDC	Top Dead Center
TP sensor	Throttle Position sensor



## A Few Words About Safety

---

Your safety, and the safety of others, is very important. And operating this motorcycle safely is an important responsibility.

To help you make informed decisions about safety, this manual contains a section devoted to *Motorcycle Safety*, as well as a number of Safety Messages throughout the manual.

Safety Messages are preceded by a safety alert symbol  and one of three signal words: **DANGER**, **WARNING**, or **CAUTION**.

These signal words mean:

 **DANGER**

You **WILL** be **KILLED** or **SERIOUSLY HURT** if you don't follow instructions.

 **WARNING**

You **CAN** be **KILLED** or **SERIOUSLY HURT** if you don't follow instructions.

 **CAUTION**

You **CAN** be **HURT** if you don't follow instructions.

Of course, it is not practical or possible to warn you about all hazards associated with operating or maintaining a motorcycle. You must use your own good judgment.

This section presents some of the most important information and recommendations to help you ride your CRF safely. Please take a few moments to read these pages. This section also includes information about the location of safety labels on your CRF.

Important Safety Information .....2  
    Important Safety Precautions.....2  
Accessories & Modifications .....3  
Safety Labels.....4

# Important Safety Information

---

## Important Safety Precautions

Your CRF can provide many years of pleasure, if you take responsibility for your own safety and understand the challenges you can meet in competitive racing.

As an experienced rider, you know there is much you can do to protect yourself when you ride. The following are a few precautions we consider to be most important.

### ***Never Carry a Passenger.***

Your CRF is designed for one operator only. Carrying a passenger can cause a crash in which you and others can be hurt.

### ***Wear Protective Gear.***

Whether you're practicing to improve your skills, or riding in competition, always wear an approved helmet, eye protection, and proper protective gear.

### ***Take Time to Get to Know Your CRF.***

Because every motorcycle is unique, take time to become thoroughly familiar with how this one operates and responds to your commands before placing your machine, and yourself, in competition.

### ***Learn and Respect Your Limits.***

Never ride beyond your personal abilities or faster than conditions warrant. Remember that alcohol, drugs, illness and fatigue can reduce your ability to perform well and ride safely.

### ***Don't Drink and Ride.***

Alcohol and riding don't mix. Even one drink can reduce your ability to respond to changing conditions, and your reaction time gets worse with every additional drink. So don't drink and ride, and don't let your friends drink and ride either.

### ***Keep your Honda in Safe Condition.***

Maintaining your CRF properly is critical to your safety. A loose bolt, for example, can cause a breakdown in which you can be seriously injured.

### ***Lithium-Ion (Li-Ion) Battery.***

If you smell an unusual odor coming from the lithium-ion (li-ion) battery, park your CRF in a safe place outside and away from flammable objects, then stop the engine. Have your CRF inspected by your dealer immediately.

### Accessories & Modifications

Installing non-Honda accessories, removing original equipment, or modifying your CRF in any way that would change its design or operation, could seriously impair your CRF's handling, stability, and braking, making it unsafe to ride.

#### **WARNING**

Improper accessories or modifications can cause a crash in which you can be seriously hurt or killed.

Follow all instructions in this owner's manual regarding modifications and accessories.

# Safety Labels

Read these labels carefully and don't remove them.

If a label comes off or becomes hard to read, contact your dealer for replacement.

(For Canada)

**AVIS IMPORTANT**  
Conducteur seulement. Aucun passager.  
Cette motocyclette est vendue sans garantie. L'acheteur prend tous les risques tant qu'à la performance et la qualité. Lire le manuel du propriétaire.  
CE VÉHICULE A ÉTÉ CONÇU ET FABRIQUÉ POUR ÊTRE EMPLOYÉ LORS DE COMPÉTITIONS SEULEMENT. NON CONFORME AUX NORMES FÉDÉRALES DE SÉCURITÉ DES VÉHICULES AUTOMOBILES OU LES NORMES AMÉRICAINES EPA ANTIPOLLUTION ET ANTIBRUIT DE MOTOCYCLETTE.  
L'utilisation sur les rues, routes, autoroutes publique ou hors route à des fins récréatives est illégale. Les lois provinciales et fédérales interdisent l'utilisation de ce véhicule sauf lors de courses organisées ou événements compétitifs sur circuit fermé. Ou par l'obtention d'un permis d'une agence gouvernementale locale ayant juridiction.

**IMPORTANT INFORMATION**   
Operator only. No passengers. This Honda Motorcycle is sold as is without warranty, and the entire risk as to quality and performance is with the buyer. Read owner's manual.  
THIS MOTORCYCLE IS DESIGNED FOR CLOSED COURSE COMPETITION USE ONLY. IT DOES NOT CONFORM TO FEDERAL MOTOR VEHICLE SAFETY STANDARDS, U.S. EPA MOTORCYCLE NOISE STANDARDS OR U.S. EPA EMISSION STANDARDS.  
Operation on public streets, roads, highways or for off-road recreation is illegal. State and Federal laws prohibit operation of this vehicle except in an organized racing or competitive event on a closed course or by permit issued by the local governmental agency having jurisdiction.

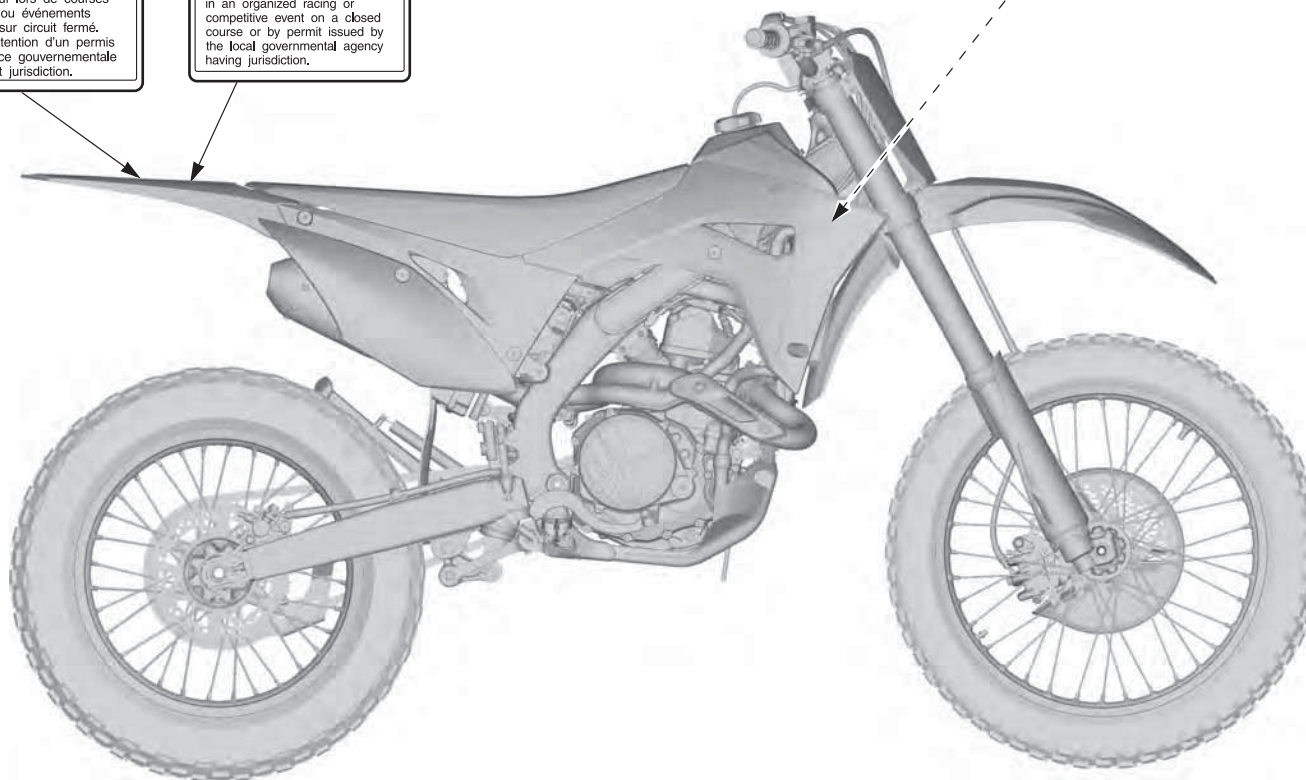

Read this section carefully before you ride. It presents the location of the basic controls on your CRF.

Operation Component Locations .....	6
MIL (Malfunction Indicator Lamp) .....	7
MIL Blink Pattern .....	7
Current DTC/Freeze DTC .....	7
Circuit Inspection.....	8
DTC Index .....	9
Engine Mode & Launch Control System Indicator & Torque Control Indicator .....	10
Engine Mode Indicator .....	10
Launch Control System Indicator .....	10
Torque Control Indicator .....	10



# Operation Component Locations

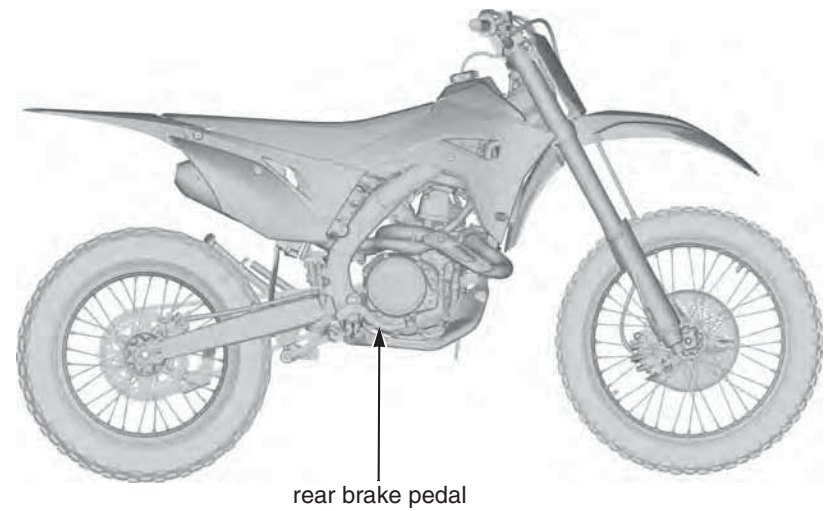
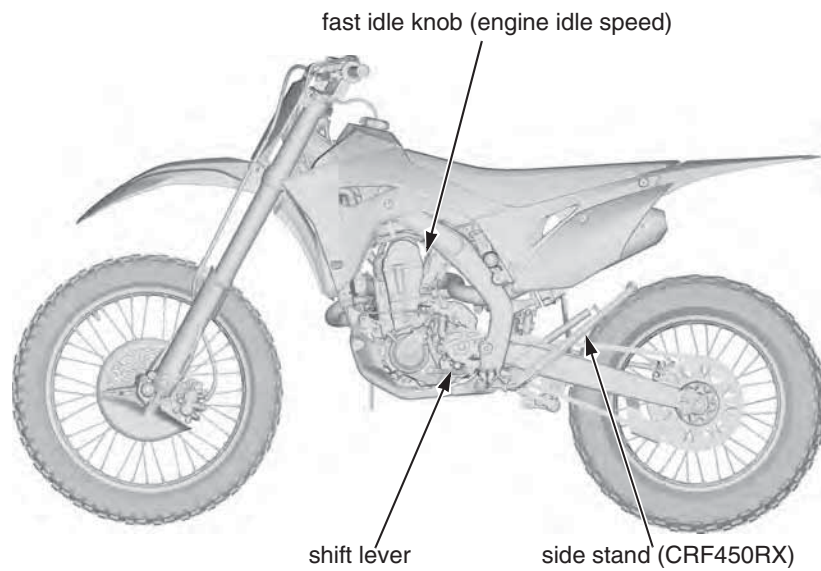
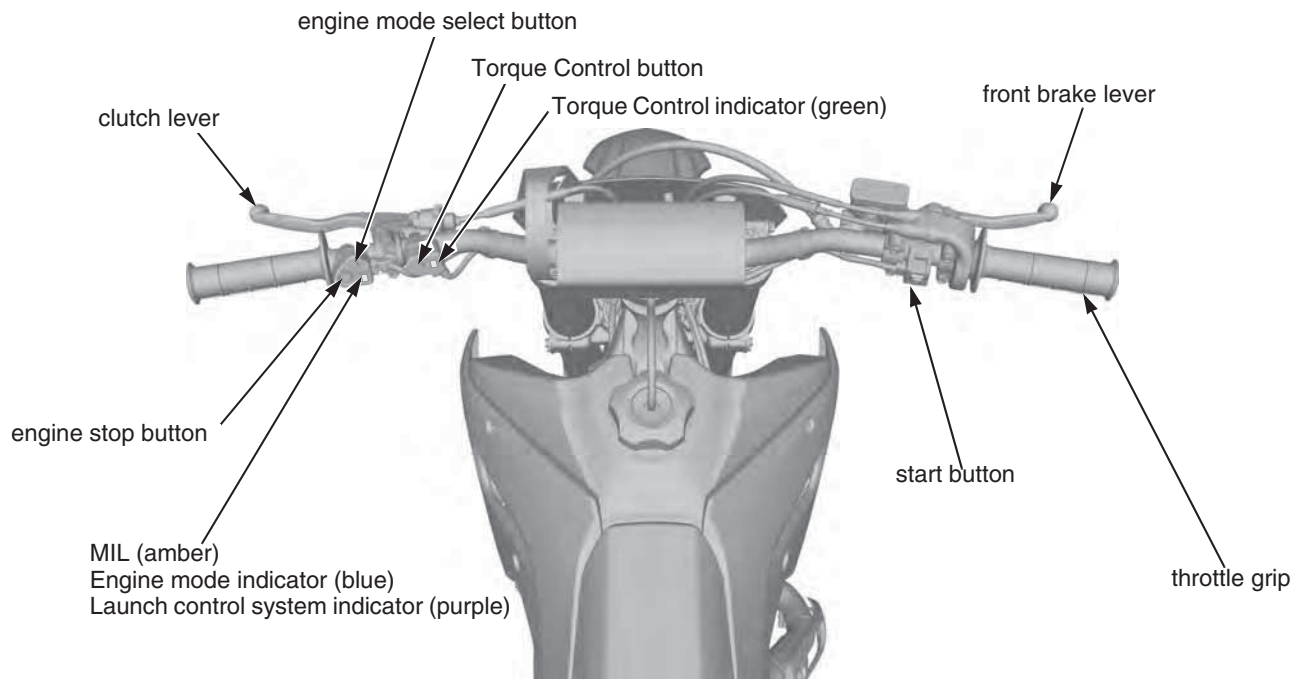

# MIL (Malfunction Indicator Lamp)

The MIL (1) on your CRF keeps you informed, alerts you to possible problems, and makes your riding safer and more enjoyable. Refer to the MIL frequently.

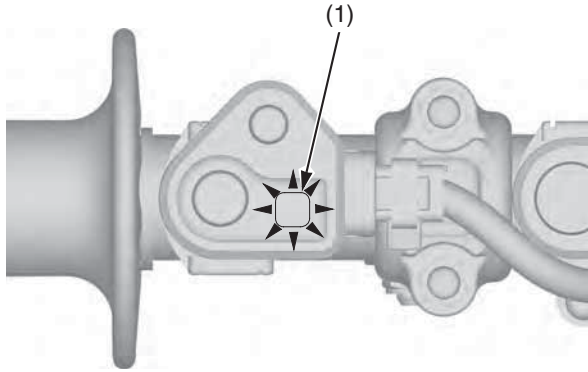

(1) MIL (amber)

When starting the engine, the MIL (amber) will stay on for 2 seconds and then go off. This is normal.

The MIL blinks when there is any abnormality in the PGM-FI system.

If the MIL comes on at any other time, reduce speed and refer to an official Honda Service Manual available for purchase from your dealer (page 186).

If the MIL does not come on when the engine is started, have your dealer check it for problems.

## MIL Blink Pattern

The MIL will blink the appropriate DTC number if the ECM detects an active problem while the engine is running at less than 4,000 rpm. The MIL will stay on when engine speed is over 4,000 rpm.

The MIL has two types of blinks: a long blink and short blink. The long blinking lasts for 1.2 seconds, the short blinking lasts for 0.4 seconds. One long blink is the equivalent of 10 short blinks. For example, when one long blink is followed by two short blinks, the MIL is 12 (one long blink = 10 blinks, plus two short blinks).

When the ECM stores more than one DTC, the MIL will indicate them by blinking in the order from the lowest number to highest number.

## Current DTC/Freeze DTC

The DTC is indicated in two ways according to the failure status.

- When the engine starts, the MIL stays on for 2 seconds, then goes off. If the ECM detects a DTC, the MIL starts blinking (indicating the DTC number by the number of blinks in amber.). Even when the MIL is blinking, you can change the engine modes. However, you cannot change the engine modes when the indicator is blinking DTC 1, 2 or 8. After an engine mode is selected, the MIL restarts blinking the current DTC number.
- In the case that the ECM does not detect an active problem but has recorded a previous problem in its memory, the MIL will not come on. If it is necessary to retrieve any past problems stored in the memory, refer to an official Honda Service Manual.

# MIL (Malfunction Indicator Lamp)

## Circuit Inspection

Always clean around the ECM and keep debris away from the connectors before disconnecting them.

A faulty PGM-FI system is often related to poorly connected or corroded connections. Check the following connections.

- (1) MAP sensor connector
- (2) ECT sensor connector
- (3) TP sensor connector
- (4) IAT sensor connector
- (5) Injector connector
- (6) CKP sensor connector
- (7) ECM connector
- (8) GP sensor connector

Remember, circuit inspection is not a “cure-all” for other problems in your engine’s PGM-FI system.

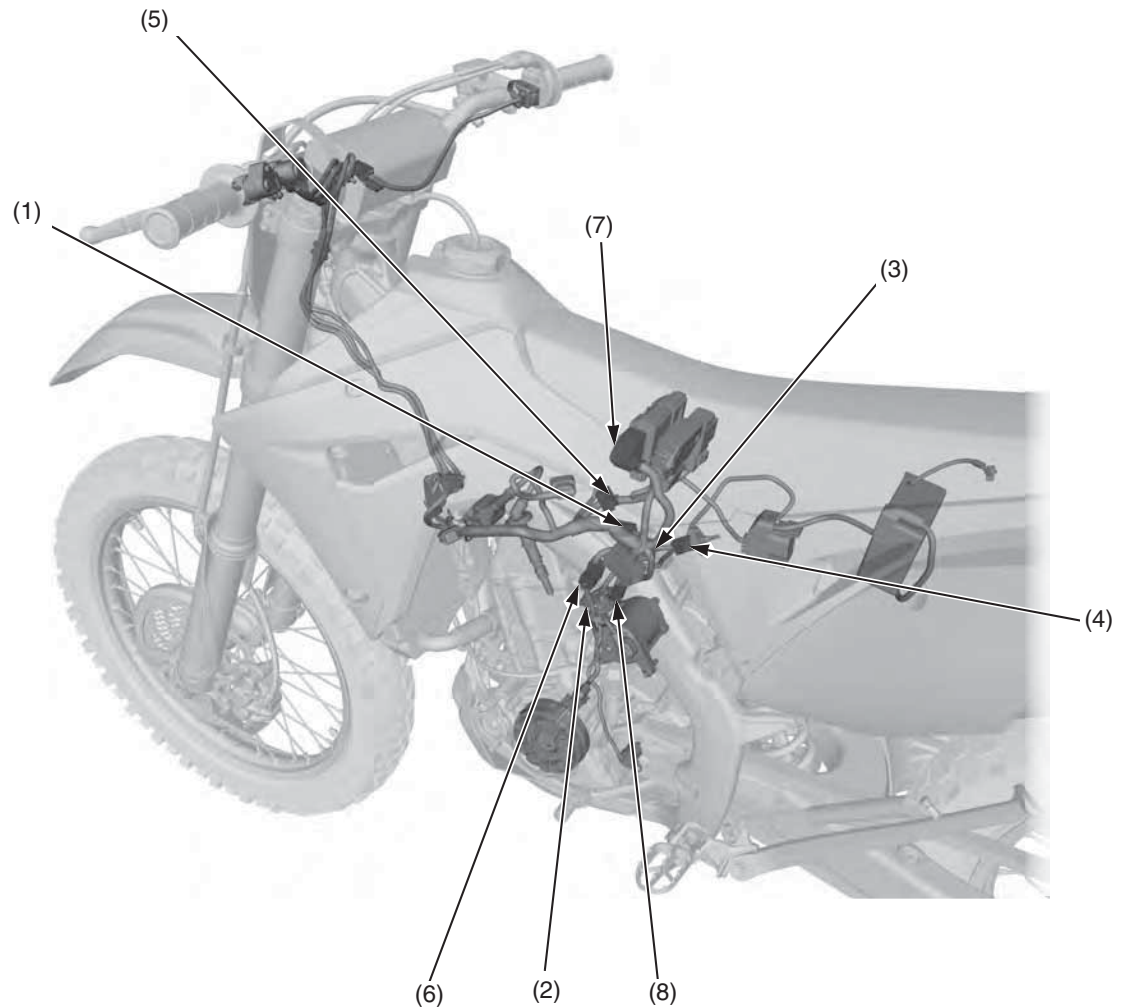

### DTC Index

Refer to *MIL Blink Pattern* on page 7.

MIL blinks	Function Failure	Symptom/Fail-safe function
1	MAP sensor circuit malfunction	Poor performance (driveability)
2	MAP sensor performance problem	Poor performance (driveability)
7	ECT sensor circuit malfunction	Hard start at a low temperature
8	TP sensor circuit malfunction	Poor engine acceleration
9	IAT sensor circuit malfunction	Engine operates normally
12	Injector circuit malfunction	<ul style="list-style-type: none"><li>• Engine does not start</li><li>• Injector, fuel pump and ignition shut down</li></ul>
41	GP sensor circuit malfunction	Engine operates normally

Should be serviced by your dealer, unless the owner has proper tools and is technically qualified.  
The series of 12 MIL blinks cannot be checked because the engine cannot be started.  
If the engine does not start, check all connector connections and/or refer to an official Honda Service Manual (page 186) for troubleshooting of the PGM-FI symptom.

# Engine Mode & Launch Control System Indicator & Torque Control Indicator

## Engine Mode Indicator

The engine mode indicator (blue) (1) is located under the engine mode select button (2). The engine mode indicator indicates the currently selected mode by blinking the mode number once when the engine is started.

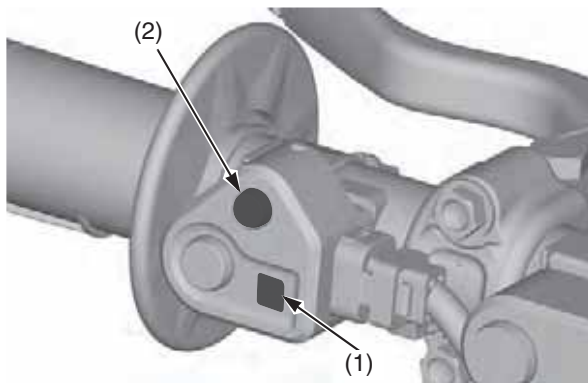

(1) engine mode indicator (blue)  
(2) engine mode select button

The engine mode indicator indicates a selected mode when you operate the engine mode select button (page 140).

If the engine mode indicator stays on or does not come on when it should, have your dealer check it for problems.

## Launch Control System Indicator

The launch control system indicator (purple) (1) is located under the engine mode select button (2). The launch control system indicator indicates the currently selected level by blinking the level number while launch control system goes into standby. The launch control system indicator (purple) comes on while the system is operating.

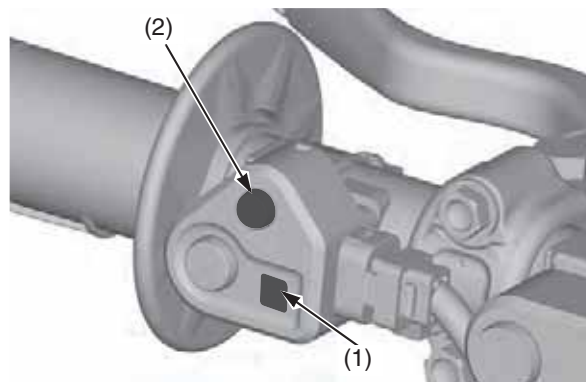

(1) launch control system indicator (purple)  
(2) engine mode select button

If the launch control system indicator does not come on when it should, have your dealer check it for problems.

## Torque Control Indicator

The Torque Control indicator (green) (1) is located to the right side of the Torque Control button (2) on the left side of the handlebar. Torque Control indicator (green) indicates the currently selected mode by blinking the mode number thrice when the engine is started. The Torque Control indicator (green) comes on while the system is operating.

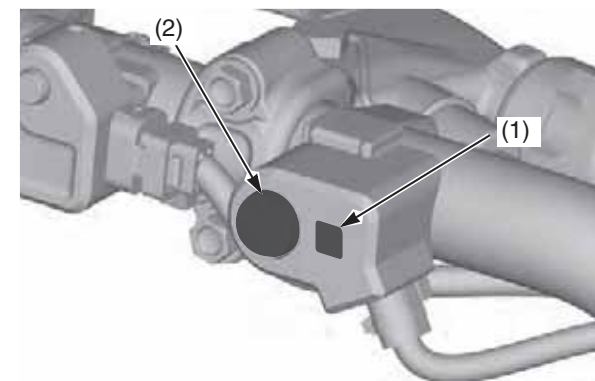

(1) Torque Control indicator (green)  
(2) Torque Control button

The Torque Control indicator indicates a selected mode when you operate the Torque Control button (page 141).

If the Torque Control indicator does not come on when it should, have your dealer check it for problems.

Before each ride, you need to make sure you and your CRF are both ready to ride. To help get you prepared, this section discusses how to evaluate your riding readiness, and what items you should check on your CRF.

For information about suspension and other adjustments, see page 139.

Are You Ready to Ride? .....	12
Is Your Motorcycle Ready to Ride? .....	13
Pre-ride Inspection .....	13



## Are You Ready to Ride?

---

Before riding your CRF for the first time, we strongly recommend that you read this owner's manual, make sure you understand the safety messages, and know how to operate the controls.

Before each ride, it's also important to make sure you and your CRF are both ready to ride.

For information about suspension and other adjustments, see page 139.

Whether you're preparing for competition or for practice, always make sure you are:

- In good physical and mental condition
- Free of alcohol and drugs
- Wearing an approved helmet, eye protection, and other appropriate riding gear

Although complete protection is not possible, wearing the proper gear can reduce the chance or severity of injury when you ride.

### **WARNING**

Not wearing a helmet increases the chance of serious injury or death in a crash.

Be sure you always wear a helmet, eye protection and other protective apparel when you ride.

Competitive riding can be tough on a motorcycle, so it's important to inspect your CRF and correct any problems you find before each ride. Check the following items (page numbers are at the right):

## **WARNING**

Improperly maintaining this motorcycle or failing to correct a problem before riding can cause a crash in which you can be seriously hurt or killed.

Always perform a pre-ride inspection before every ride and correct any problems.

## Pre-ride Inspection

Check the following before each ride:

- Engine oil level ..... 63
- Fuel line for condition ..... 42
- Coolant for proper level..... 65
- Cooling system and hoses for condition .... 66
- Spark plug for proper heat range, carbon fouling and spark plug wire terminal for looseness ..... 78
- Air cleaner for condition and contamination ..... 67
- Clutch lever freeplay..... 73
- Breather drain for cleaning ..... 69
- Steering head bearing and related parts for condition ..... 132
- Throttle operation ..... 71
- Tires for damage or improper inflation pressure ..... 119
- Spokes for looseness..... 118
- Rim locks for looseness ..... 118
- Front and rear suspension for proper operation ..... 97, 113
- Front and rear brakes, check operation..... 114
- Drive chain for correct slack and adequate lubrication ..... 122, 123
- Drive chain sliders and drive chain rollers for damage or wear ..... 122, 123
- Exhaust pipe/Muffler for looseness ..... 126
- Every possible part for looseness (such as cylinder head bolts, engine mounting bolts/nuts, axle nuts, handlebar holder bolts, fork bridge pinch bolts, drive chain adjuster, lock nuts, drive chain roller bolt/nut, wire harness connectors)..... 175-177
- MIL operation ..... 7

BLANK PAGE

This section gives basic information on how to start and stop your engine as well as break-in guidelines.

Safe Riding Precautions.....	16
Side Stand (CRF450RX) .....	16
Honda Selectable Torque Control.....	16
Starting & Stopping the Engine .....	17
Fast Idle Knob.....	17
Preparation .....	17
Starting Procedure.....	17
How to Stop the Engine .....	18
Parking (CRF450RX) .....	19
Break-in Guidelines .....	20

# Basic Operating Instructions

## Safe Riding Precautions

Before riding your CRF for the first time, please review the *Important Safety Precautions* beginning on page 2 and the previous section, titled *Before Riding*.

For your safety, avoid starting or operating the engine in an enclosed area such as a garage. Your CRF's exhaust contains poisonous carbon monoxide gas which can collect rapidly in an enclosed area and cause illness or death.

### **WARNING**

Running the engine of your vehicle while in an enclosed or even partially enclosed area can cause a rapid build-up of toxic carbon monoxide gas.

Breathing this colorless, odorless gas can quickly cause unconsciousness and lead to death.

Only run your vehicle's engine when it is located in a well ventilated area outdoors.

## Side Stand (CRF450RX)

The side stand (1) is used to support your CRF while parked (page 19). To operate, push the side stand down. Slowly lean your CRF to the left until its weight rests on the side stand. Turn the handlebar fully to the left.

Before riding, raise the side stand.

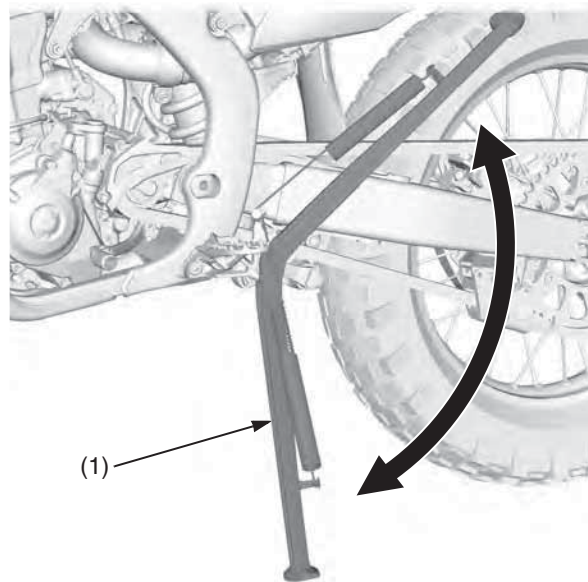

(1) side stand

## Honda Selectable Torque Control

When the Honda selectable torque control (Torque Control) detects rear wheel spin during acceleration, the system will limit the amount of torque applied to the rear wheel based on the Torque Control level selected.

Rear wheel spin during acceleration is reduced at the higher Torque Control level setting. Select a level that is appropriate for your skill and riding conditions.

Torque Control does not work during deceleration and will not prevent the rear wheel from skidding due to engine braking.

Do not close the throttle suddenly, especially when riding on slippery surfaces.

Torque Control may not compensate for rough track conditions or rapid throttle operation. Always consider track and weather conditions, as well as your skills and condition, when applying throttle.

Always use the recommended tires and sprockets to ensure correct Torque Control operation.

Always follow the proper starting procedure described below.

Your CRF can be started with the transmission in gear by pulling in the clutch lever before operating the start button.

## Fast Idle Knob

The fast idle knob has two functions:

- When pulled out, the fast idle knob assists in first-time start-up for cold weather starting.
- When pushed in, it acts like an idle adjustment screw. Refer to *Idle Speed Adjustment* on page 72.

## Preparation

Make sure that the transmission is in neutral.

## Starting Procedure

Always follow the proper starting procedure described as follows.

Check the engine oil and coolant levels before starting the engine (pages 63, 65).

### Cold Engine Starting

1. Shift the transmission into neutral.
2. If the temperature is 50°F (10°C) or below, pull the fast idle knob (1) fully up.

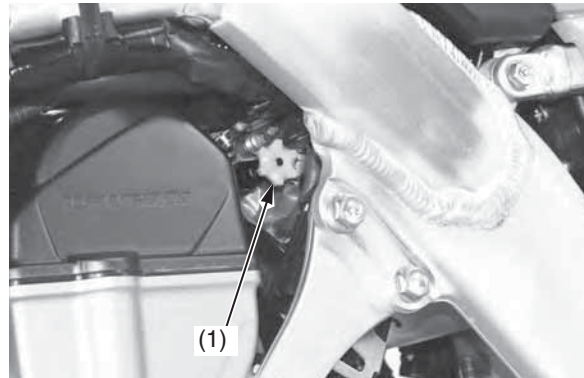

(1) fast idle knob

3. With the throttle closed.  
Pull the clutch lever all the way in, and depress the start button (2).

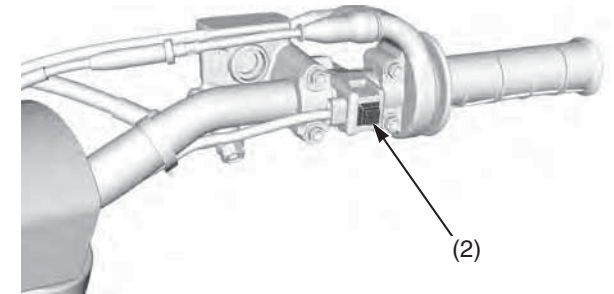

(2) start button

4. About a minute after the engine starts, push the fast idle knob back all the way to fully OFF. If idling is unstable, open the throttle slightly.



# Starting & Stopping the Engine

## Warm Engine Starting

1. Shift the transmission into neutral.
2. Pull the clutch lever and depress the start button. (Do not open the throttle.)

## Starting the engine excessively charged with fuel by throttle blipping or other reasons

1. Shift the transmission into neutral.
2. With the throttle fully opened, pull the clutch and depress the start button for 5 seconds to discharge excessive fuel from the engine.
3. Pull the clutch lever and depress the start button. (Do not open the throttle.)

Snapping the throttle or fast idling for more than about 5 minutes may cause exhaust pipe and muffler discolorations.

When starting the engine, the MIL (amber) will stay on for 2 seconds, then go off. And then the engine mode indicator (blue) indicates the current engine mode for 0.8 seconds, then goes off. If the MIL/engine mode indicator (1) does not come on or go off when it should, have your dealer check it for problems.

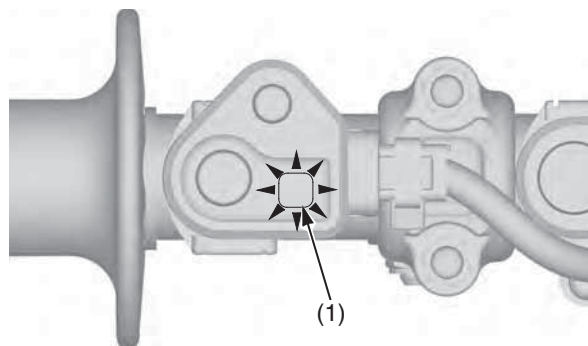

(1) MIL (amber) / engine mode indicator (blue)

## How to Stop the Engine

### Normal Engine Stop

1. Shift the transmission into neutral.
2. Push and hold the engine stop button (1) until the engine stops completely.

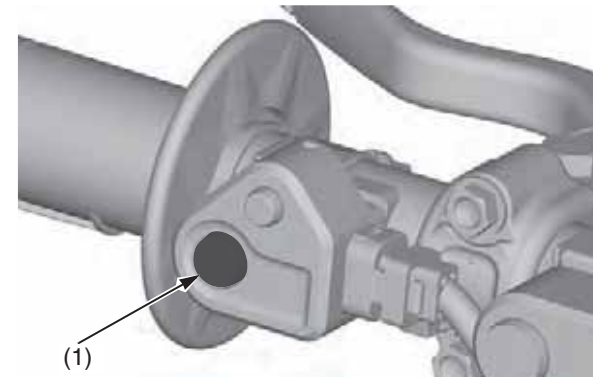

(1) engine stop button

### Emergency Engine Stop

To stop the engine in an emergency, push and hold the engine stop button.

Lower the side stand to support your CRF.  
Always choose a level surface to park.

## Break-in Guidelines

---

Help assure your CRF's future reliability and performance by paying extra attention to how you ride during the first operating day or 15 miles (25 km).

During this period, avoid full-throttle starts and rapid acceleration.

This same procedure should be followed each time when:

- piston is replaced
- piston rings are replaced
- cylinder is replaced
- crankshaft or crank bearings are replaced

Keeping your CRF well maintained is absolutely essential to your safety. It's also a good way to protect your investment, get maximum performance, avoid breakdowns, and have more fun.

To help keep your CRF in good shape, this section includes a Maintenance Schedule for required servicing and step-by-step instructions for specific maintenance tasks. You'll also find important safety precautions, information on oils, and tips for keeping your CRF looking good.

An ECM system is used on this motorcycle; consequently, routine ignition timing adjustment is unnecessary. If you want to check the ignition timing, refer to an official Honda Service Manual (page 186).

An optional tool kit may be available. Check with your dealer's parts department.

## *Before You Service Your Honda*

The Importance of Maintenance .....	22
Maintenance Safety .....	23
Important Safety Precautions .....	23
Maintenance Schedule .....	24
General Competition Maintenance .....	27
Before & After Competition Maintenance .....	31
Between Races (CRF450RX)/Motos (CRF450R/RWE) & Practice Maintenance .....	31
After Competition Maintenance .....	32

## *Service Preparations*

Maintenance Component Locations .....	33
Seat .....	34
Fuel Tank (CRF450RX) .....	35
Fuel Tank (CRF450R/RWE) .....	37
Subframe .....	39

## *Service Procedures*

### Fluids & Filters

Fuel System (CRF450RX) .....	42
Fuel System (CRF450R/RWE) .....	52
Engine Oil .....	62
Coolant .....	65
Air Cleaner .....	67
Crankcase Breather .....	69

### Engine

Throttle .....	70
Engine Idle Speed .....	72
Clutch System .....	73
Spark Plug .....	78
Valve Clearance .....	79
Piston/Piston Rings/Piston Pin .....	88

### Chassis

Suspension .....	97
Front Suspension Inspection .....	97
Rear Suspension Inspection .....	113
Brakes .....	114
Wheels .....	118
Tires & Tubes .....	119
Side Stand (CRF450RX) .....	121
Drive Chain .....	122
Exhaust Pipe/Muffler .....	126
Additional Maintenance Procedures .....	132

### Electrical

Battery .....	134
---------------	-----

Appearance Care .....	136
-----------------------	-----

# The Importance of Maintenance

---

Keeping your CRF well-maintained is absolutely essential to your safety. It's also a good way to get maximum performance during each race (CRF450RX)/moto (CRF450R/RWE).

Careful pre-ride inspections and good maintenance are especially important because your CRF is designed to be ridden in off-road competition.

Remember, proper maintenance is your responsibility. Be sure to inspect your CRF before each ride and follow the Maintenance Schedule in this section.

## **WARNING**

Improperly maintaining this motorcycle or failing to correct a problem before you ride can cause a crash in which you can be seriously hurt or killed.

Always follow the inspection and maintenance recommendations and schedules in this owner's manual.

This section includes instructions on how to perform some important maintenance tasks. Some of the most important safety precautions follow. However, we cannot warn you of every conceivable hazard that can arise in performing maintenance. Only you can decide whether or not you should perform a given task.

## WARNING

Failure to properly follow maintenance instructions and precautions can cause you to be seriously hurt or killed.

Always follow the procedures and precautions in this owner's manual.

### Important Safety Precautions

- Make sure the engine is off before you begin any maintenance or repairs. This will help eliminate several potential hazards:

**Carbon monoxide poisoning from engine exhaust.** Be sure there is adequate ventilation whenever you operate the engine.

**Burns from hot motorcycle parts.** Let the engine and exhaust system cool before touching.

**Injury from moving parts.** Do not run the engine unless instructed to do so.

- Read the instructions before you begin, and make sure you have the tools and skills required.
- To help prevent the motorcycle from falling over, park it on a firm, level surface, using the side stand (CRF450RX), an optional workstand or a maintenance stand to provide support.
- To reduce the possibility of a fire or explosion, be careful when working around gasoline. Use only a non-flammable (high flash point) solvent such as kerosene –not gasoline– to clean parts. Keep cigarettes, sparks, and flames away from all fuel-related parts.



# Maintenance Schedule

---

To maintain the safety and reliability of your CRF, regular inspection and service is required as shown in the Maintenance Schedule that follows.

The Maintenance Schedule lists items that can be performed with basic mechanical skills and hand tools. Procedures for these items are provided in this manual.

The Maintenance Schedule also includes items that involve more extensive procedures and may require special training, tools, and equipment. Therefore, we recommend that you have your dealer perform these tasks unless you have advanced mechanical skills and the required tools. Procedures for items in this schedule are provided in an official Honda Service Manual available for purchase from your dealer (page 186).

Service intervals in the maintenance schedule are expressed in terms of races (CRF450RX)/motos (CRF450R/RWE) and riding hours. To avoid overlooking required service, we urge you to develop a convenient way to record the number of races (CRF450RX)/motos (CRF450R/RWE) and/or hours you ride.

If you do not feel capable of performing a given task or need assistance, remember that your Honda dealer knows your CRF best and is fully equipped to maintain and repair it. If you decide to do your own maintenance, use only Honda Genuine Parts or their equivalents for repair or replacement to ensure the best quality and reliability.

Perform the *pre-ride inspection* (page 13) at each scheduled maintenance period.

## *Summary of Maintenance Schedule Notes and Procedures:*

### Notes:

1. (CRF450RX)  
Clean after every race for dusty riding condition.  
(CRF450R/RWE)  
Clean after every moto for dusty riding condition.
2. Replace every 2 years. Replacement requires mechanical skill.
3. Replace after the first break-in ride.
4. Inspect after the first break-in ride.
5. Replace the engine oil, if the clutch discs and plates are replaced.
6. Replace every year.

### Maintenance Procedures:

I : inspect and clean, adjust, lubricate or replace if necessary

C : clean

A : adjust

L : lubricate

R : replace

# Maintenance Schedule (CRF450RX)

Perform the *Pre-ride Inspection* (page 13) at each scheduled maintenance period.

I: Inspect and Clean, Adjust, Lubricate or Replace if necessary. C: Clean. R: Replace. A: Adjust. L: Lubricate.

ITEMS	FREQUENCY	CRF450RX NOTE	Each race or about 3.5 hours	Every 2 races or about 7.5 hours	Every 4 races or about 15.0 hours	Every 6 races or about 22.5 hours	Every 8 races or about 30.0 hours	Ref. Page
FUEL LINE		(NOTE 6)	I				R	42
FUEL PUMP FILTER		(NOTE 6)					R	46 – 51
THROTTLE OPERATION			I					71
AIR FILTER		(NOTE 1)	C					67, 68
CRANKCASE BREATHER			I					69
SPARK PLUG			I					78
VALVE CLEARANCE/DECOMPRESSOR SYSTEM		(NOTE 4)			I			79 – 87
ENGINE OIL		(NOTE 3) (NOTE 5)	I		R			63
ENGINE OIL FILTER		(NOTE 3)			R			63, 64
ENGINE IDLE SPEED			I					72
PISTON AND PISTON RINGS					R			90 – 92
PISTON PIN					R			90 – 92
RADIATOR COOLANT		(NOTE 2)	I					65, 66
COOLING SYSTEM			I					66
DRIVE CHAIN			I, L	R				122 – 124
DRIVE CHAIN SLIDER			I					122
DRIVE CHAIN ROLLER			I					123
DRIVE SPROCKET			I					124
DRIVEN SPROCKET			I					124
BRAKE FLUID		(NOTE 2)	I					115, 116
BRAKE PADS WEAR			I					117
BRAKE SYSTEM			I					114
CLUTCH SYSTEM		(NOTE 5)	I					73 – 77
CONTROL CABLES			I, L					132
EXHAUST PIPE/MUFFLER			I					126 – 130
SUSPENSION			I					97, 113
SWINGARM/SHOCK LINKAGE				L				30, 113
FORK OIL		(NOTE 3)				R		100, 101, 105 – 113
NUTS, BOLTS, FASTENERS			I					133, 175 – 177
WHEELS/TIRES			I					118 – 120
STEERING HEAD BEARINGS						I		132
SIDE STAND			I					121

WE RECOMMEND THESE ITEMS BE SERVICED BY REFERRING TO THE OFFICIAL HONDA SERVICE MANUAL.

This maintenance schedule is based upon average riding condition. Machine subjected to severe use require more frequent servicing.

NOTE: 1. Clean after every race for dusty riding condition.

2. Replace every 2 years. Replacement requires mechanical skill.

3. Replace after the first break-in ride.

4. Inspect after the first break-in ride.

5. Replace the engine oil, if the clutch discs and plates are replaced.

6. Replace every year.

# Maintenance Schedule (CRF450R/RWE)

Perform the *Pre-ride Inspection* (page 13) at each scheduled maintenance period.

I: Inspect and Clean, Adjust, Lubricate or Replace if necessary. C: Clean. R: Replace. A: Adjust. L: Lubricate.

ITEMS	FREQUENCY	CRF450R/RWE NOTE	Each race or about 2.5 hours	Every 3 races or about 7.5 hours	Every 6 races or about 15.0 hours	Every 9 races or about 22.5 hours	Every 12 races or about 30.0 hours	Ref. Page
FUEL LINE		(NOTE 6)	I				R	52
FUEL PUMP FILTER		(NOTE 6)					R	52 – 61
THROTTLE OPERATION			I					71
AIR FILTER		(NOTE 1)	C					67, 68
CRANKCASE BREATHER			I					69
SPARK PLUG			I					78
VALVE CLEARANCE/DECOMPRESSOR SYSTEM		(NOTE 4)			I			79 – 87
ENGINE OIL		(NOTE 3) (NOTE 5)	I		R			63
ENGINE OIL FILTER		(NOTE 3)			R			63, 64
ENGINE IDLE SPEED			I					72
PISTON AND PISTON RINGS					R			90 – 92
PISTON PIN					R			90 – 92
RADIATOR COOLANT		(NOTE 2)	I					65, 66
COOLING SYSTEM			I					66
DRIVE CHAIN			I, L	R				122, 123, 125
DRIVE CHAIN SLIDER			I					122
DRIVE CHAIN ROLLER			I					123
DRIVE SPROCKET			I					124
DRIVEN SPROCKET			I					124
BRAKE FLUID		(NOTE 2)	I					115, 116
BRAKE PADS WEAR			I					117
BRAKE SYSTEM			I					114
CLUTCH SYSTEM		(NOTE 5)	I					73 – 77
CONTROL CABLES			I, L					132
EXHAUST PIPE/MUFFLER			I					126 – 130
SUSPENSION			I					97, 113
SWINGARM/SHOCK LINKAGE				L				30, 113
FORK OIL		(NOTE 3)				R		100, 101, 105 – 113
NUTS, BOLTS, FASTENERS			I					133, 175 – 177
WHEELS/TIRES			I					118 – 120
STEERING HEAD BEARINGS						I		132

WE RECOMMEND THESE ITEMS BE SERVICED BY REFERRING TO THE OFFICIAL HONDA SERVICE MANUAL.

This maintenance schedule is based upon average riding condition. Machine subjected to severe use require more frequent servicing.

NOTE: 1. Clean after every moto for dusty riding condition.

2. Replace every 2 years. Replacement requires mechanical skill.

3. Replace after the first break-in ride.

4. Inspect after the first break-in ride.

5. Replace the engine oil, if the clutch discs and plates are replaced.

6. Replace every year.

Perform maintenance on firm, level ground using the side stand (CRF450RX), an optional workstand, or equivalent support.

When tightening bolts, nuts or screws, start with the larger diameter or inner fasteners, and tighten them to the specified torque using a crisscross pattern.

Use Honda Genuine Parts or their equivalents when servicing your CRF.

Clean parts in non-flammable (high flash point) cleaning solvent (such as kerosene) when disassembling. Lubricate any sliding surfaces, O-rings, and seals before reassembling. Grease parts by coating or filling where specified.

After any engine disassembly, always install new gaskets, O-rings, cotter pins, piston pin clips, snap rings, etc. when reassembling. After reassembly, check all parts for proper installation and operation.

### **All Pre-ride Inspection Items**

Refer to *Pre-ride Inspection* on page 13.

# General Competition Maintenance

## Spark Plug

Some non-resistor plugs may cause ignition problems. Refer to the recommendations elsewhere in this manual for specific types so you will be sure to use the proper reach and heat range. Replace periodically as specified in the Maintenance Schedule (pages 25, 26).

## Spark Plug Cap

Install a small plastic wire band around the spark plug cap to reduce any possibility of it loosening or of water penetration.



## Air Cleaner

Clean and oil your air cleaner regularly because the volume of air able to pass through it has a great effect on performance. Both engine performance and long term durability may be affected by an air cleaner that has deteriorated and allows dirt to pass. Inspect the air cleaner closely each time it's serviced for evidence of small tears or seam separation. Keep a spare air cleaner oiled and ready to install, sealed in a plastic bag. Riding in dusty conditions may require servicing the air cleaner or replacing it with a pre-serviced air cleaner between races (CRF450RX)/motos (CRF450R/RWE). Be careful not to over oil the air cleaner. While it is important to oil the air cleaner thoroughly, over oiling will cause an overall rich running condition, probably more noticeable off idle and in low rpm performance. Follow the servicing instructions in the Maintenance section. Use Pro Honda Foam Air Filter Oil or an equivalent. Be sure to grease the air cleaner flange where it contacts the air cleaner housing. Pro Honda Foam Air Filter Sealer or an equivalent is handy for this because any dirt that penetrates this sealing area will show up clearly (page 67). Use the Honda Genuine air cleaner or an equivalent air cleaner specified for your model. Using the wrong Honda air cleaner or a non-Honda air cleaner which is not of equivalent quality may cause premature engine wear or performance problems.

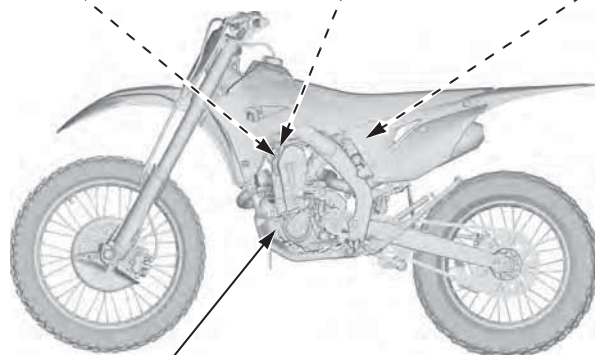

## Engine Oil and Filter

Drain and replace engine oil often to ensure the greatest service life of the piston, cylinder, crankshaft, transmission and clutch.

Also replace engine oil filter often to ensure the greatest service life. Frequent changes will also assure consistent performance of power, response, both shifting and clutch action (page 63).

## Handgrips

CRF450RX/R

Always use Honda Bond A, Pro Honda Handgrip Cement (U.S.A. only) when replacing handgrips.

CRF450RWE

Always use double-sided tape of Honda genuine parts when replacing handgrips.

Refer to an official Honda Service Manual (page 186) for installation instructions.

## Throttle Grip/Handlebar Grip

Right throttle grip: Align the index mark on the throttle grip with the index mark of the throttle pipe.

Left handlebar grip: Align the index mark on the left handlebar grip with the paint mark on the handlebar.

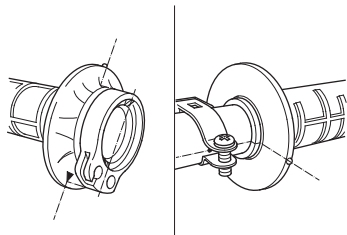

For added security, you may choose to bind the handgrips to the handlebar and throttle pipe with safety wires to prevent the possibility of them loosening. Position the twisted wire ends away from your palms and be sure to bend the wire ends well into the handgrip rubber so they will not snag your glove.

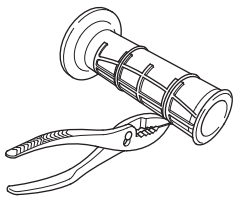

## Fork Oil/Performance

Disassemble, clean and inspect the fork and replace the oil regularly. Contamination due to the tiny metal particles produced from the normal action of the fork, as well as normal oil breakdown, will deteriorate the performance of the suspension. Refer to an official Honda Service Manual (page 186). Use only Pro Honda HP Fork Oil, A15-00 or an equivalent which contains special additives to assure maximum performance of your CRF's front suspension.

## Gaskets

Always use new gaskets when reassembling components.

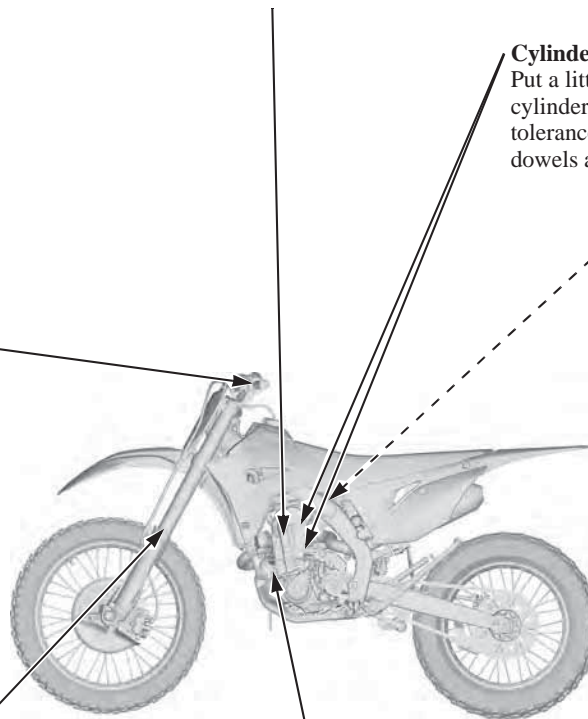

## Cylinder head/Cylinder

Put a little grease on the dowel pins of the cylinder head and cylinder to prevent corrosion from dissimilar metals. The tolerances are quite tight, so it's important to keep these dowels absolutely clean (pages 93, 94).

## Fuel Line

Refer to *Fuel Line Inspection* on pages 42 and 52. Check the fuel line for deterioration, damage, or leakage. Replace the fuel line every year.

## Fuse

Check the fuse before looking elsewhere for the cause of an electrical problem.

## Battery

The start button uses current from the battery. Limited operation also allows the battery to discharge. If you do not ride frequently, we recommend that you charge the battery frequently (see *Battery Charging* on page 135). If you do not expect to ride your CRF for at least 2 weeks, we recommend you remove the battery – or at least disconnect the battery cables (negative cable first).

## Electrical Connectors

Clean electrical connectors and wrap them with electrical tape to reduce the possibility of unwanted disconnections, water shorts or corrosion.

## Frame

Because your CRF is a high-performance machine, the frame should not be overlooked as part of your overall competition maintenance program. Periodically inspect the frame closely for possible cracking or other damage. It makes good racing sense.

## Engine Mounting Bolts and Nuts

Make sure the engine mounting bolts and nuts are tightened to the proper torque specification.

# General Competition Maintenance

## Suspension Linkage Lubrication

Disassemble, clean, inspect and lubricate all suspension linkage pivot bearings with molybdenum disulfide grease (containing more than 3% molybdenum disulfide additive Moly Paste 77) after each 7.5 hours of running time in order to maintain proper suspension performance and minimize component wear.

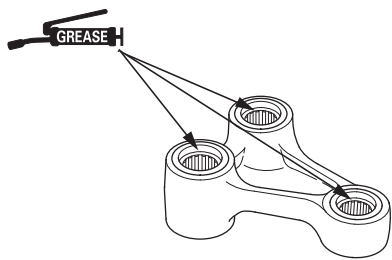

## Swingarm Pivot Lubrication

Clean, inspect and lubricate the swingarm and suspension linkage pivots with molybdenum disulfide grease (containing more than 3% molybdenum disulfide additive Moly Paste 77). Be sure all of the dust seals are in good condition.

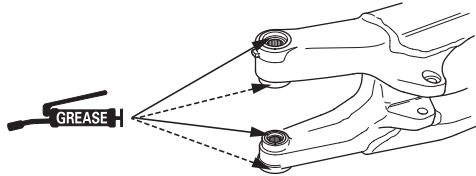

## Swingarm

Do not attempt to weld or otherwise repair a damaged swingarm. Welding will weaken the swingarm.

## Footpegs

Worn footpeg teeth can be repaired by filing the grooves between the teeth with a triangular shaped file. Be aware that filing them too sharp will reduce boot sole lifespan. Sharpen only the points of the teeth. Filing the grooves deeper will weaken the footpegs. Be sure the pegs are free to pivot freely and that the pivot pin retaining cotter pins are in good condition.



## Brake Fluid Replacement

Refer to *Brake Pad Wear* on page 117.

**Brake Caliper Inspection:** Be sure both the front and rear calipers are able to move freely on the caliper pin and caliper bracket pins. Check pad thickness periodically and replace the pads when minimum thickness is reached. If the brakes fade when they are hot, inspect the pads for glazing or damage, and replace if necessary.

**Brake Fluid Replacement:** Refer to an official Honda Service Manual (page 186) for brake fluid replacement instructions. Replace the brake fluid in the brake system every 2 years. Replace the fluid more frequently if you subject your brakes to severe use. Heavy braking heats the brake fluid and it may deteriorate sooner than expected. Any type of riding, that requires frequent use of the brakes, such as in tight woods, can shorten the service life of brake fluid.

## Throttle Control

Remove the throttle control every few rides, clean the inside of the throttle pipe and handlebar thoroughly. Inspect the cable carefully for kinks or other damage that may restrict throttle control in anyway. Move the handlebar from lock to lock to be sure there is no cable interference. Make certain the throttle operation is perfect after servicing and inspecting.

## Steering Head Bearings

Periodically clean, inspect and regrease the steering head bearings — especially if wet, muddy or extremely dusty courses are encountered often.

Use urea based multi-purpose grease designed for high temperature, high pressure performance (example: EXCELITE EP2 manufactured by KYODO YUSHI, Japan or equivalent).

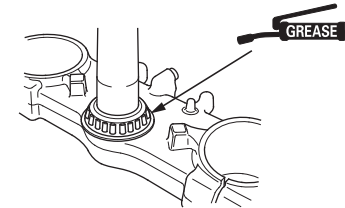

## Spokes

Check spoke tension frequently between the first few rides. As the spokes, spoke nuts and rim contact points seat-in, the spokes may need to be retightened. Once past this initial seating-in period, the spokes should hold their tension. Still, be sure your race (CRF450RX)/moto (CRF450R/RWE) maintenance program includes checking spoke tension and overall wheel condition on a regular basis (page 118).

## Nuts, Bolts, Etc.

Application of a thread locking agent to essential fasteners offers added assurance and security. Remove the nuts, clean the threads of both the nuts and bolts, apply Pro Honda Hondalock or an equivalent and tighten to the specified torque (page 175 - 177).

## Bleed Hole

After every race (CRF450RX)/moto (CRF450R/RWE), check the bleed hole below the water pump cover for leakage. Clean away any clogged dirt or sand, if necessary. Check for signs of seal leakage. If water leaks through the bleed hole, replace the mechanical seal. If oil leaks through the bleed hole, replace the oil seal. Make sure that there is no continuous coolant leakage from the bleed hole while operating the engine. A small amount of coolant weeping from the bleed hole is normal. See an official Honda Service Manual or consult your dealer for replacing the mechanical seal or oil seal. Both seals should be replaced at the same time.



## Between Races (CRF450RX)/Motos (CRF450R/RWE) & Practice Maintenance

After practice or between races (CRF450RX)/motos (CRF450R/RWE) you have a chance to make additional checks and adjustments.

- Clean accumulated dirt from under the fenders and off the wheels, suspension components, handgrips, controls, and footpegs. A stiff, nylon parts cleaning brush works well.
- Check tire air pressure.
- Check spoke tension, and make sure the rim locks are secure.

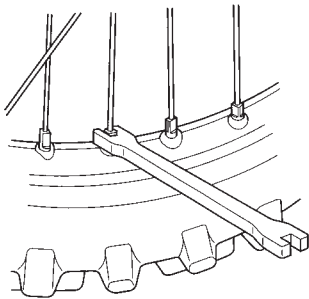

- Check to make sure the sprocket bolts and nuts are secure.
- Clean the sides of the drive chain with a stiff, nylon parts-cleaning brush. Lubricate and adjust the chain as necessary.

Do not perform maintenance while engine is running. Injury to your fingers or hands may result.

- After adjustment, check that the chain adjuster index marks (1) are in the same position on each side. This will ensure that the rear wheel is in proper alignment and allow maximum performance from the rear disc brake. Maintaining proper wheel alignment will also extend brake pad lifespan.

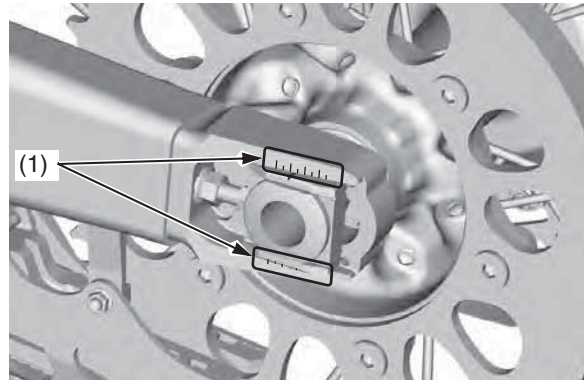

(1) chain adjuster index marks

- Suspend the front wheel above the ground and use the pressure release screws (2) to release the built-up pressure in the forks. This pressure is caused by normal fork action while riding.

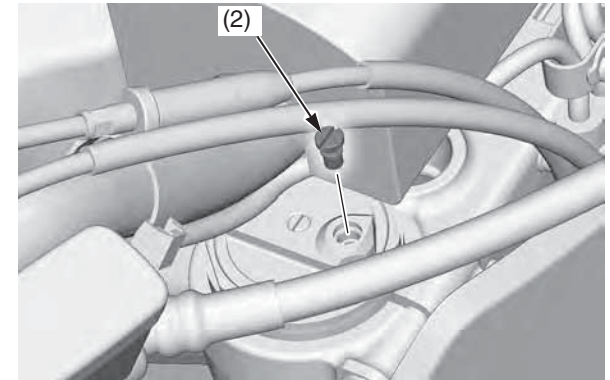

(2) pressure release screw



# Before & After Competition Maintenance

## After Competition Maintenance

It is important to the long term performance of your CRF to practice a consistent maintenance program. Right after the event is a good time to begin your next maintenance cycle.

### After Race (CRF450RX)/Moto (CRF450R/RWE) Lubrication

Apply a light coating of rust-inhibiting oil to the drive sprocket and any steel portions of the chassis or engine where the paint has worn away. This will prevent rusting of the exposed metal. Apply rust-inhibiting oil more heavily if the event was particularly wet or muddy. Take care to avoid spraying any oil near the brake pads or the brake discs.

Take care to prevent catching your fingers between the chain and sprocket.

Remove the drive chain, clean and lubricate it (pages 123 – 124). Be sure the chain is wiped clean and is dry before lubricating the chain.

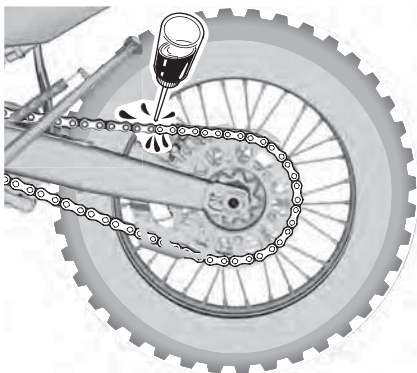

### Routine Cleaning

If your CRF is only slightly dirty, it is best to clean it by hand with the aid of a stiff bristled nylon brush and some clean rags.

Take care to prevent catching your fingers between the chain and sprocket.

A variety of reasonably priced cleaning brushes are available from variety, drug, food, and hardware stores. Some of these brushes are extremely useful in removing dirt from the many tight contours of the metal pieces of your CRF. Avoid using stiff, abrasive brushes on the plastic or rubber parts.

If your CRF was exposed to sea air or salt water, rinse it as soon as possible after the event, dry it, and apply a spray lubricant to all metal parts.

If you decide to wash your CRF or use cleaners, refer to *Appearance Care* (page 136).

# Maintenance Component Locations

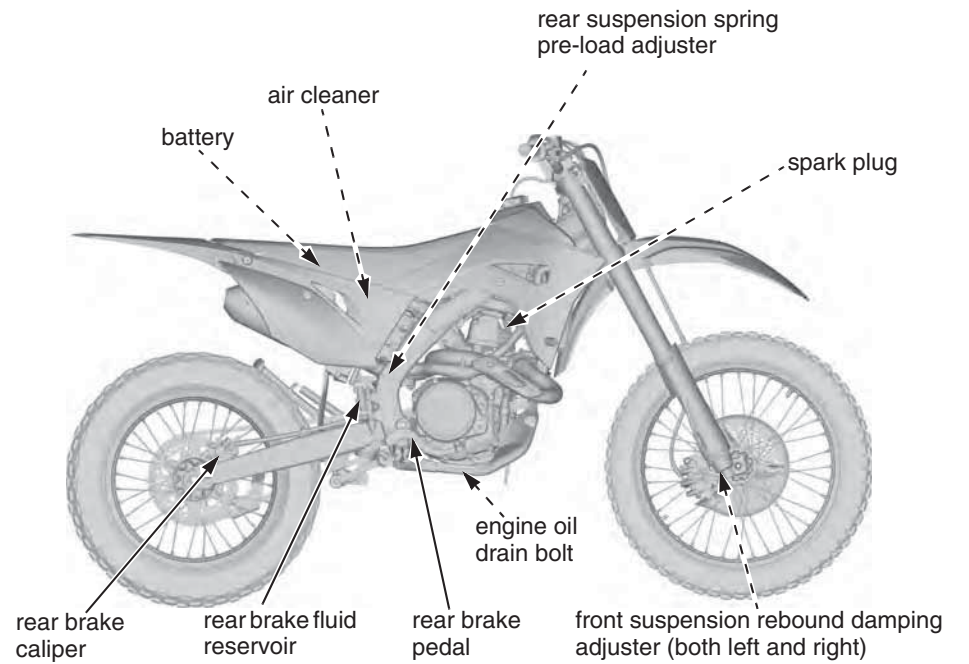
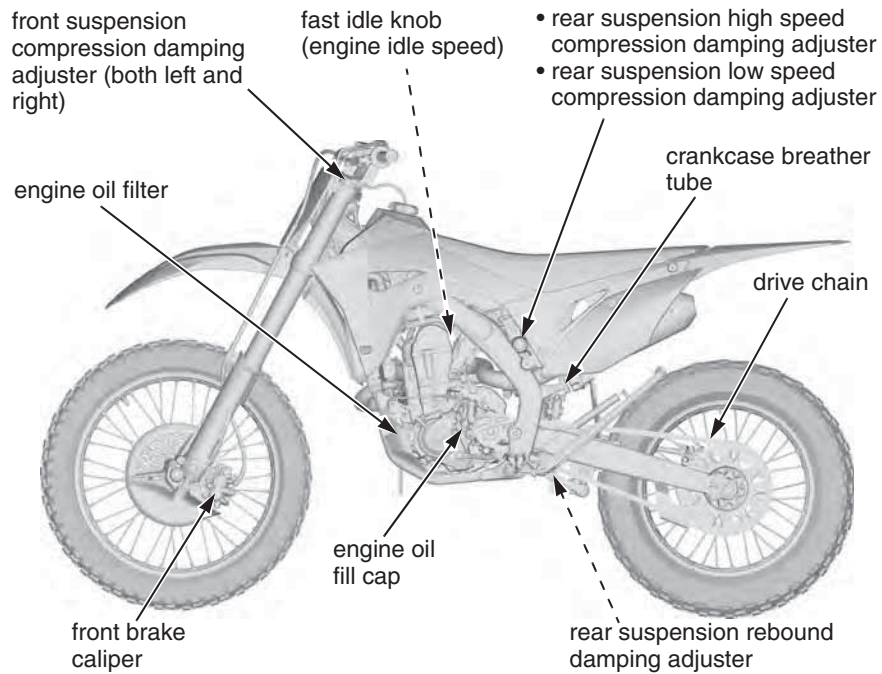
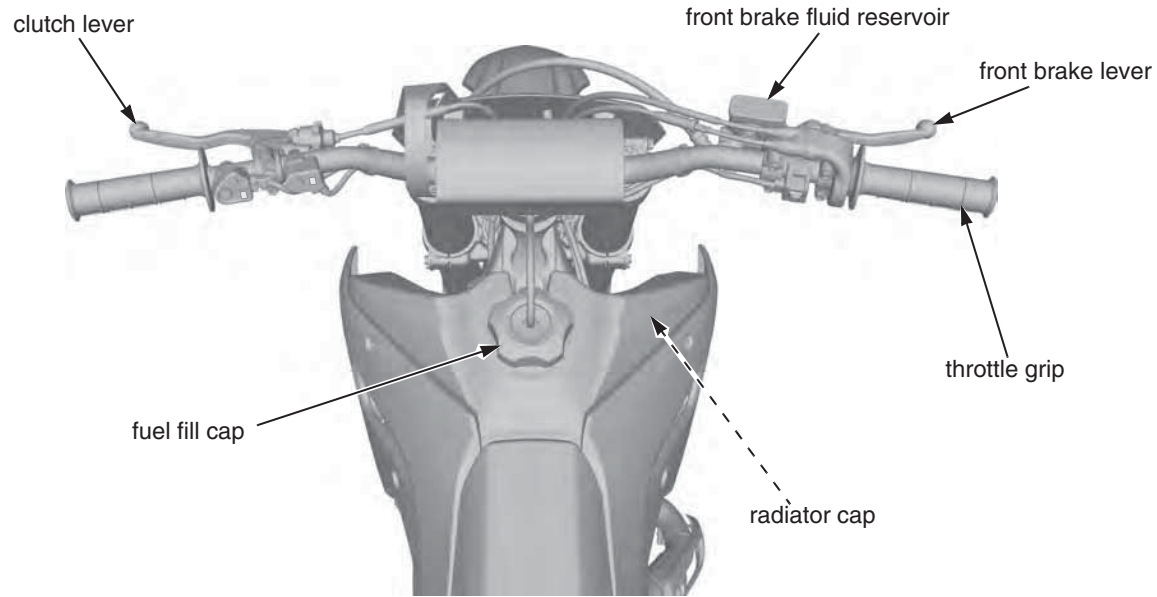

# Seat

Refer to *Important Safety Precautions* on page 23.

## Removal

1. Remove the seat mounting bolts (1) and collars (2).
2. Remove the seat (3) by pulling it backward.

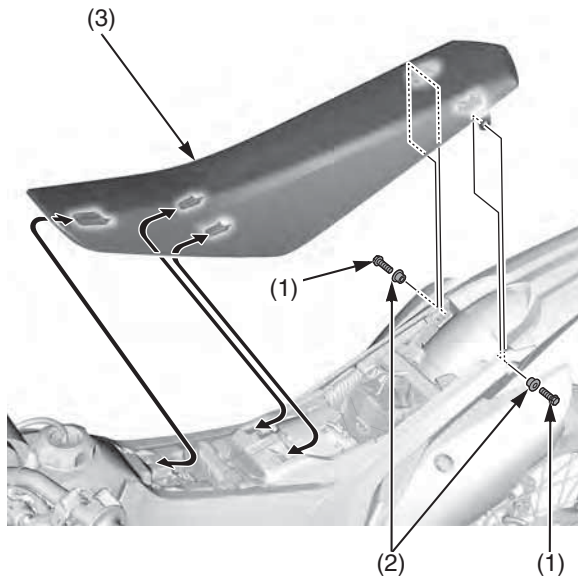

(1) seat mounting bolts  
(2) collars  
(3) seat

## Installation

1. Install the seat while aligning the seat front prong (1) with the slot (2) of the fuel tank and seat center prongs (3) with the seat support base slots (4).
2. Install and tighten the collars (5) and seat mounting bolts (6) to the specified torque:  
19 lbf·ft (26 N·m, 2.7 kgf·m)

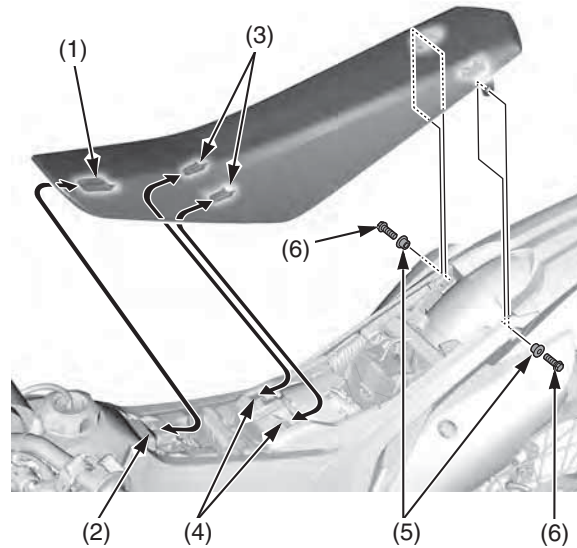

(1) seat front prong  
(2) slot  
(3) seat center prongs  
(4) seat support base slots  
(5) collars  
(6) seat mounting bolts

## Fuel Tank (CRF450RX)

Refer to *Important Safety Precautions* on page 23.

### Removal

1. Remove the seat (page 34).
2. Remove the shroud A bolt (1), shroud B bolt (2), shroud C bolt (3) and shroud D bolt (4).
3. Slide the shroud (5) toward the up to separate them from the air cleaner housing cover (6), and then remove the shroud.

The right and left shrouds can be removed in the same manner.

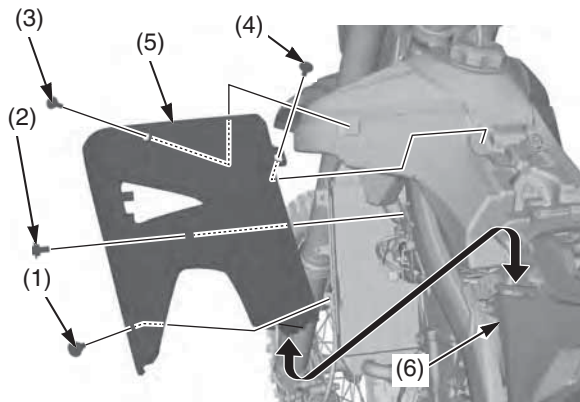

- (1) shroud A bolt
- (2) shroud B bolt
- (3) shroud C bolt
- (4) shroud D bolt
- (5) shroud
- (6) air cleaner housing cover

4. Install a hose clamp (7) to the breather tube (8) and set the hose clamp securely.
5. Pull the breather tube out of steering stem nut (9).

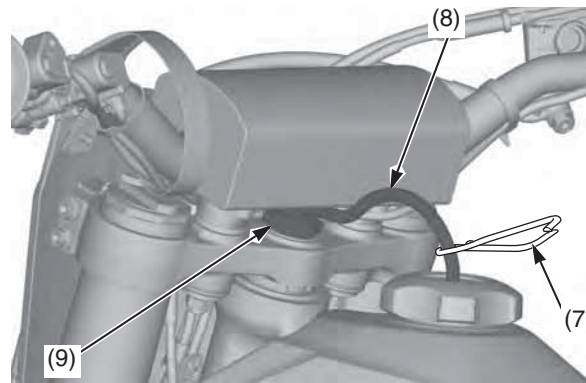

- (7) hose clamp
- (8) breather tube
- (9) steering stem nut

6. Remove the fuel tank bolt (10) and collar (11).
7. Unhook the fuel tank band (12).

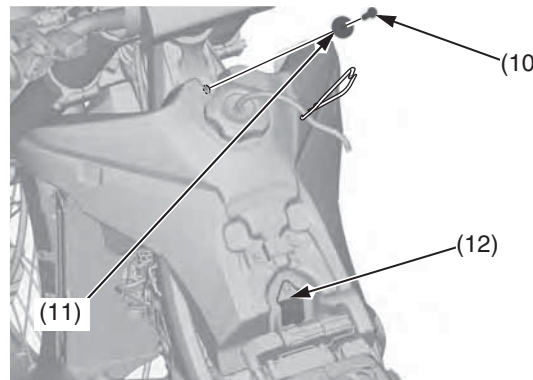

- (10) fuel tank bolt
- (11) collar
- (12) fuel tank band

8. Lift the fuel tank (13) out of the frame and hang it to the left of the frame. Check the fuel tank stopper cable (14) for deterioration, kinks or other damage.

Do not support the fuel tank by the fuel feed hose (15).

### ⚠ WARNING

Gasoline is highly flammable and explosive.

You can be burned or seriously injured when handling fuel.

- Stop the engine and keep heat, sparks and flame away.
- Handle fuel only outdoors.
- Wipe up spills immediately.

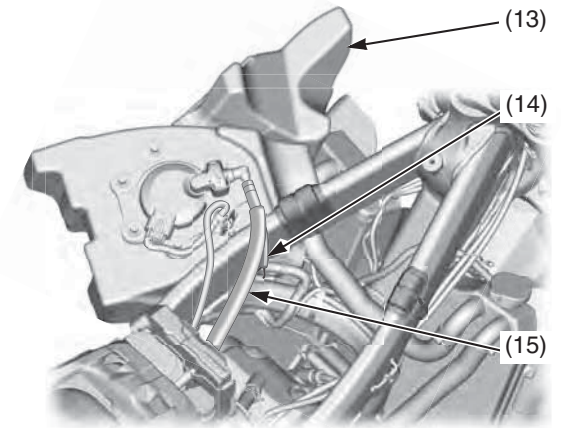

- (13) fuel tank
- (14) fuel tank stopper cable
- (15) fuel feed hose

(cont'd)



# Fuel Tank (CRF450RX)

9. Check for interference between the frame and tank, and adjust the cushion rubbers (16) on the both sides of the frame if necessary.

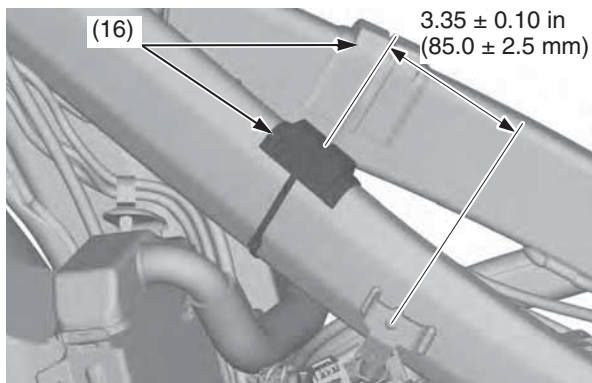

(16) cushion rubbers

## Installation

1. Install the fuel tank (1) on the frame.
2. Install and tighten the collar (2) and fuel tank bolt (3) to the specified torque:  
7 lbf-ft (10 N·m, 1.0 kgf-m)
3. Hook the fuel tank band (4).

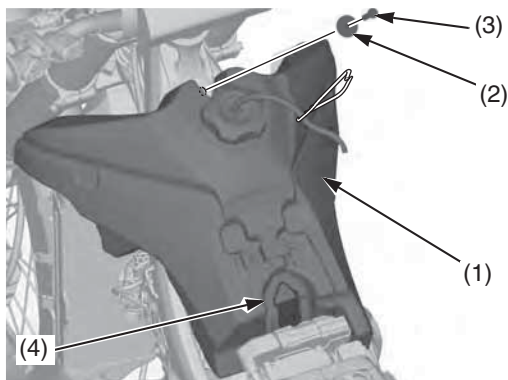

(1) fuel tank  
(2) collar  
(3) fuel tank bolt  
(4) fuel tank band

4. Put the breather tube (5) in the steering stem nut (6).
5. Remove the hose clamp (7) from the breather tube.

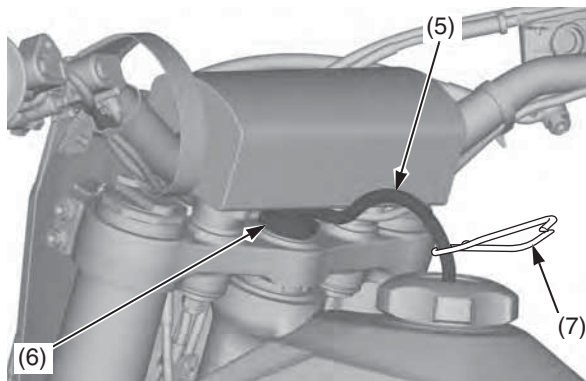

(5) breather tube  
(6) steering stem nut  
(7) hose clamp

6. Slide the shroud (8) toward the down so that the shroud tab (9) and the slot (10) on the air cleaner housing cover (11) is aligned.
7. Install the shroud D bolt (12), shroud C bolt (13), shroud B bolt (14) and shroud A bolt (15). Tighten the shroud A and B bolts to the specified torque:  
7 lbf-ft (10 N·m, 1.0 kgf-m)  
Tighten the shroud C and D bolts to the specified torque:  
3.8 lbf-ft (5.2 N·m, 0.5 kgf-m)

The right and left shrouds can be installed in the same manner.

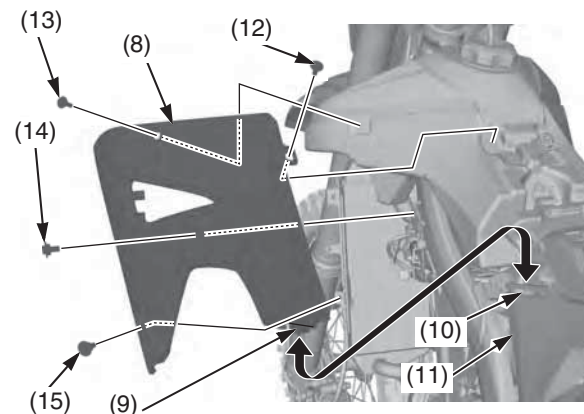

(8) shroud  
(9) tab  
(10) slot  
(11) air cleaner housing cover  
(12) shroud D bolt  
(13) shroud C bolt  
(14) shroud B bolt  
(15) shroud A bolt

8. Install the seat (page 34).

# Fuel Tank (CRF450R/RWE)

Refer to *Important Safety Precautions* on page 23.

## Removal

1. Remove the seat (page 34).
2. Remove the shroud A bolt (1), shroud B bolt (2) and shroud C bolt (3).
3. Slide the shroud (4) toward the up to separate them from the air cleaner housing cover (5), and then remove the shroud.

The right and left shrouds can be removed in the same manner.

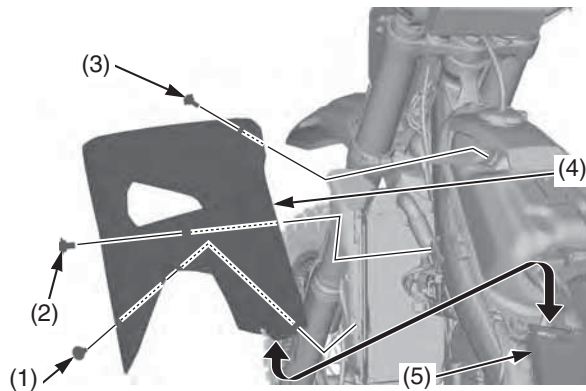

- (1) shroud A bolt  
(2) shroud B bolt  
(3) shroud C bolt  
(4) shroud  
(5) air cleaner housing cover

4. Install a hose clamp (6) to the breather tube (7) and set the hose clamp securely.
5. Pull the breather tube out of steering stem nut (8).

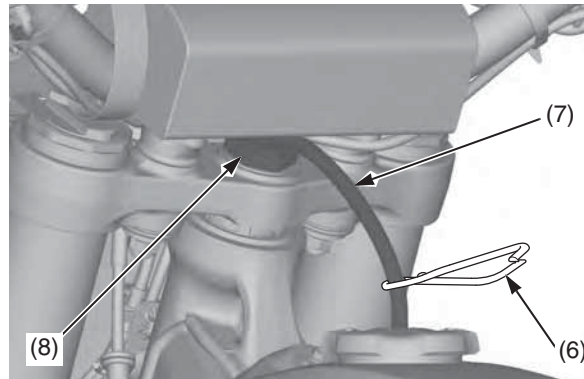

- (6) hose clamp  
(7) breather tube  
(8) steering stem nut

6. Remove the fuel tank bolts (9) and washers (10).

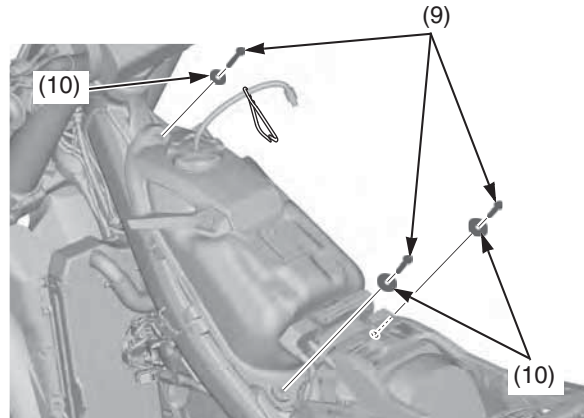

- (9) fuel tank bolts  
(10) washers

7. Lift the fuel tank (11) out of the frame and hang it to the left of the frame. Check the fuel tank stopper cable (12) for deterioration, kinks or other damage.

Do not support the fuel tank by the fuel feed hose (13).

## NOTICE

*The fuel tank is made of titanium material. Since the fuel tank has not been painted, it might be discolored with mud and dust. To remove mud or dust, use a sponge or soft cloth and a stainless steel kitchen detergent, then rinse well clean water. After washing, rinse with plenty of water and dry with a clean cloth.*

## ⚠ WARNING

Gasoline is highly flammable and explosive. You can be burned or seriously injured when handling fuel.

- Stop the engine and keep heat, sparks and flame away.
- Handle fuel only outdoors.
- Wipe up spills immediately.

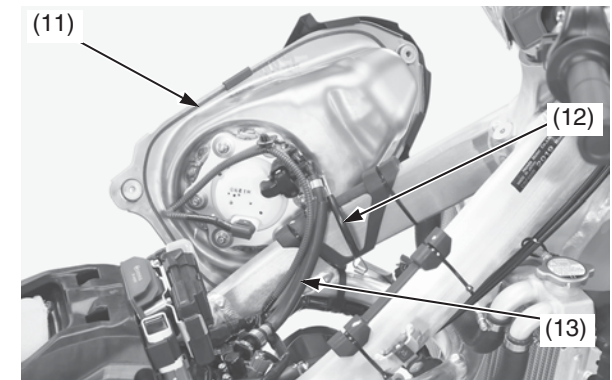

- (11) fuel tank  
(12) fuel tank stopper cable  
(13) fuel feed hose

(cont'd)

## Fuel Tank (CRF450R/RWE)

- Check for interference between the frame and tank, and check the cushion rubbers (14) on both sides of the frame for hardening or cracks.

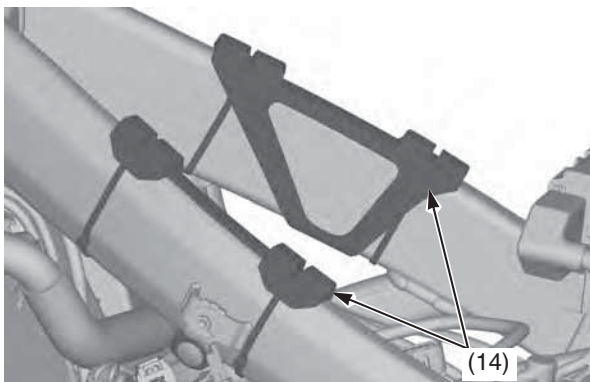

(14) cushion rubbers

### NOTICE

*Do not ride your CRF if the cushion rubbers have been removed.  
It may cause fuel tank cracking.*

### Installation

- Install the fuel tank (1) on the frame.
- Install and tighten the washers (2) and fuel tank bolts (3) to the specified torque:  
7 lbf-ft (10 N·m, 1.0 kgf·m)

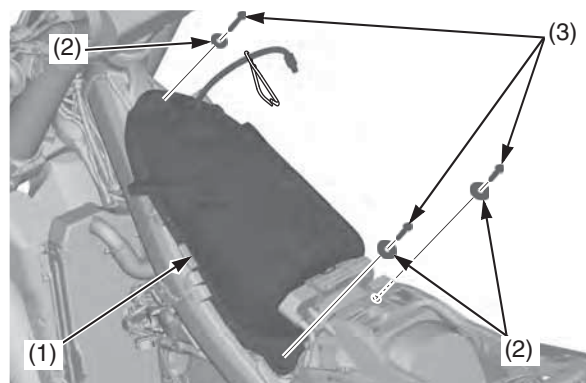

(1) fuel tank  
(2) washers  
(3) fuel tank bolts

- Put the breather tube (4) in the steering stem nut (5).
- Remove the hose clamp (6) from the breather tube.

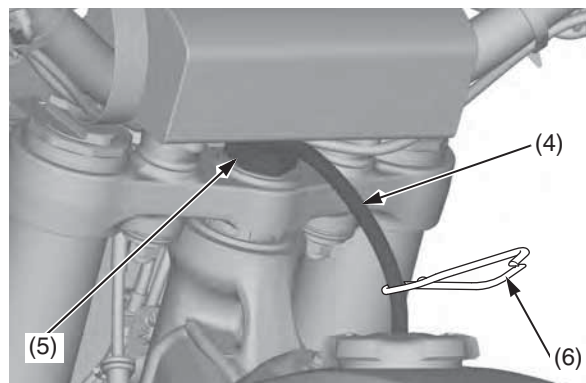

(4) breather tube  
(5) steering stem nut  
(6) hose clamp

- Slide the shroud (7) toward the down so that the shroud tab (8) and the slot (9) on the air cleaner housing cover (10) is aligned.
- Install the shroud C bolt (11), B bolt (12) and shroud A bolt (13).  
Tighten the shroud A and B bolts to the specified torque:  
7 lbf-ft (10 N·m, 1.0 kgf·m)  
Tighten the shroud C bolt to the specified torque:  
3.8 lbf-ft (5.2 N·m, 0.5 kgf·m)

The right and left shrouds can be installed in the same manner.

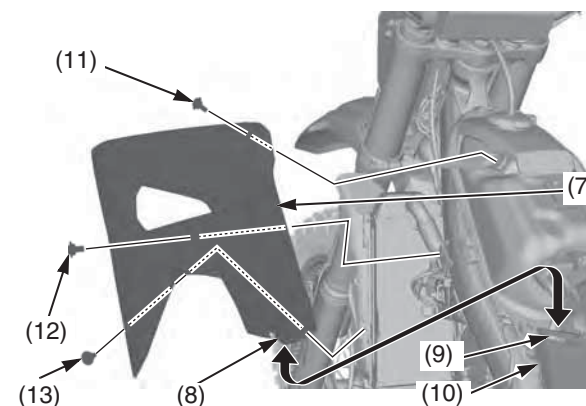

(7) shroud  
(8) tab  
(9) slot  
(10) air cleaner housing cover  
(11) shroud C bolt  
(12) shroud B bolt  
(13) shroud A bolt

- Install the seat (page 34).



Refer to *Important Safety Precautions* on page 23.

## Removal

1. Remove the seat (page 34).
2. Remove the right and left shrouds (page 35, page 37).
3. Remove the right and left mufflers (page 126).
4. Remove the right and left exhaust springs A, then remove the right and left muffler mounting A bolts (page 130). (CRF450RWE only)
5. Remove the seat support base mounting bolts (1), and collars (2).

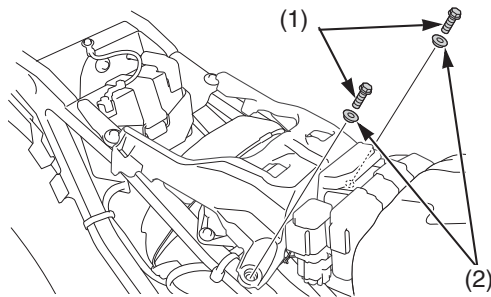

- (1) seat support base mounting bolts  
(2) collars

6. Disconnect the starter/ignition relay connector (3), lift the seat support base (4), and hang it to the left of the subframe (5).

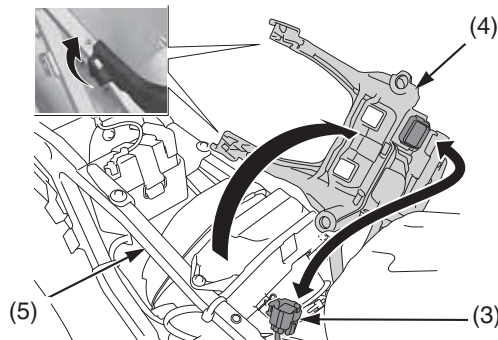

- (3) starter/ignition relay connector  
(4) seat support base  
(5) subframe

7. Disconnect the breather tube (6) and IAT sensor connector (7).
8. Loosen the air cleaner connecting tube clamp screw (8).

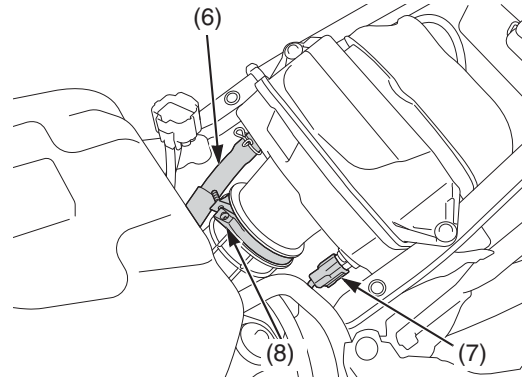

- (6) breather tube  
(7) IAT sensor connector  
(8) air cleaner connecting tube clamp screw

9. Disconnect the negative (-) terminal (9) from the battery (10).

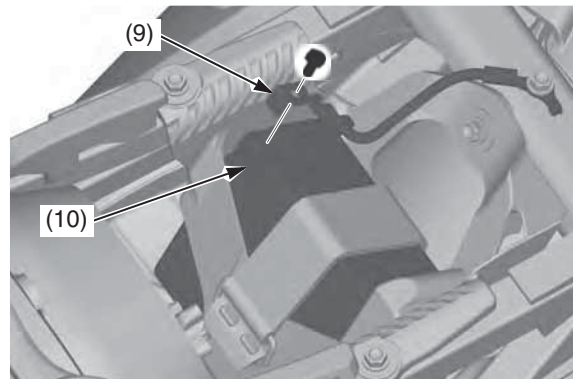

- (9) negative (-) terminal  
(10) battery

10. Remove the start magnetic switch stay bolt (11) and plastic wire band (12). Pull out the start magnetic switch (13). Remove the start magnetic switch cover (14). Remove the battery cable terminal bolt (15) and disconnect the battery cable terminal (16) from the start magnetic switch.

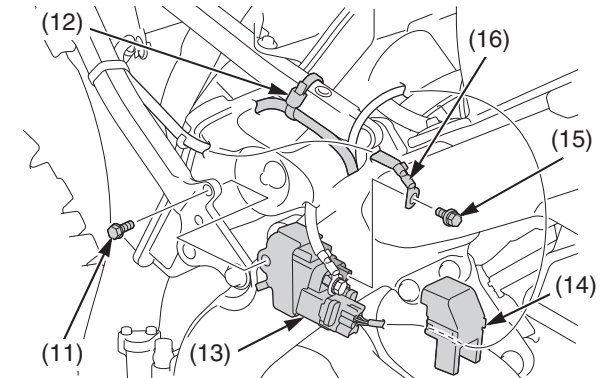

- (11) start magnetic switch stay bolt  
(12) wire band  
(13) start magnetic switch  
(14) start magnetic switch cover  
(15) battery cable terminal bolt  
(16) battery cable terminal

(cont'd)



# Subframe

11. Remove the subframe lower bolts (17) and upper bolts (18).  
Remove the subframe (5) while disconnecting the air cleaner connecting tube (19).

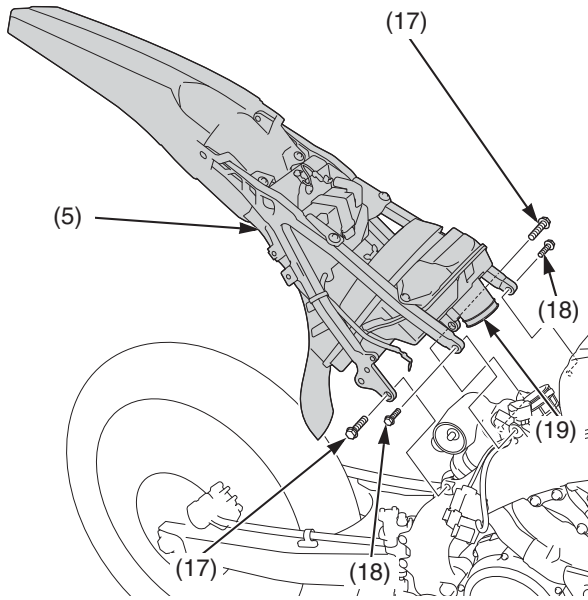

- (5) subframe  
(17) subframe lower bolts  
(18) subframe upper bolts  
(19) air cleaner connecting tube

## Installation

1. Align the upper and lower ends of the subframe to the main frame while connecting the air cleaner box (1) to the air cleaner connecting tube (2), and loosely install all subframe bolts.

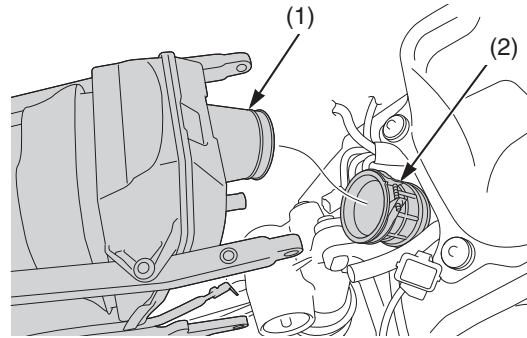

- (1) air cleaner box  
(2) air cleaner connecting tube

2. Tighten the subframe upper bolts (3) first and then tighten the lower bolts (4) to the specified torque:

subframe upper bolts:  
24 lbf-ft (32 N·m, 3.3 kgf·m)

subframe lower bolts:  
36 lbf-ft (49 N·m, 5.0 kgf·m)

Left side:

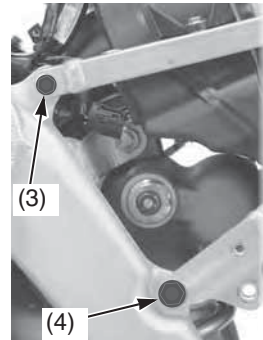

Right side:

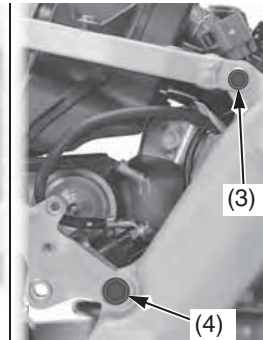

- (3) subframe upper bolts  
(4) subframe lower bolts

3. Connect the battery cable terminal (5) to the start magnetic switch (6).  
Install and tighten the battery cable terminal bolt (7) to the specified torque:  
5.2 lbf-ft (7 N·m, 0.7 kgf·m)  
Install the start magnetic switch cover (8).  
Install the start magnetic switch.  
Install and tighten the start magnetic switch stay bolt (9) to the specified torque:  
9 lbf-ft (12 N·m, 1.2 kgf·m)  
Install the plastic wire band (10).

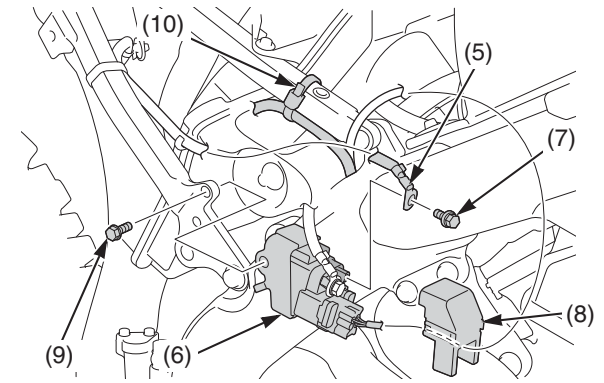

- (5) battery cable terminal  
(6) start magnetic switch  
(7) battery cable terminal bolt  
(8) start magnetic switch cover  
(9) start magnetic switch stay bolt  
(10) wire band

- Connect the negative (-) terminal (11) to the battery (12).  
Tighten the negative (-) terminal bolt (13) to the specified torque:  
1.5 lbf·ft (2.0 N·m, 0.2 kgf·m)

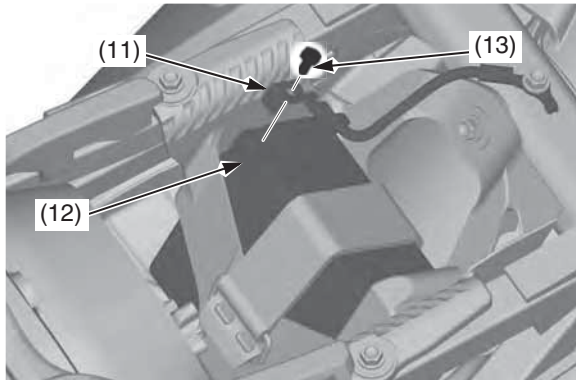

- (11) negative (-) terminal
- (12) battery
- (13) negative (-) terminal bolt

- Make sure that the air cleaner box and the air cleaner connecting tube are correctly connected and tighten the air cleaner connecting tube clamp screw (14) so the distance between the clamp ends is 0.24 - 0.35 in (6 - 9 mm).
- Connect the breather tube (15) and IAT sensor connector (16).

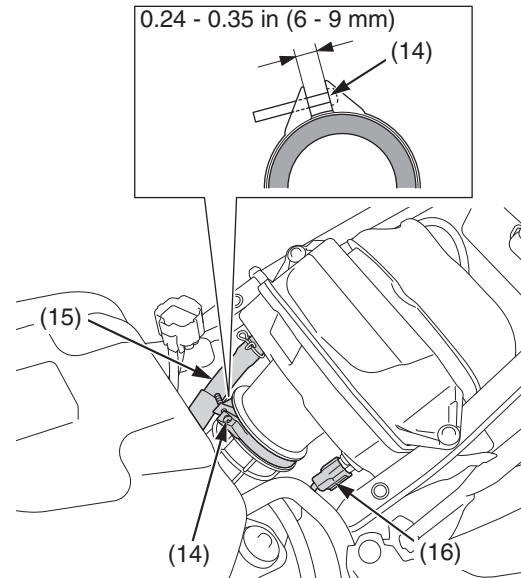

- (14) air cleaner connecting tube clamp screw
- (15) breather tube
- (16) IAT sensor connector

- Connect the starter/ignition relay connector (17) and install the seat support base (18).
- Install and tighten the collars (19), and seat support base mounting bolts (20) to the specified torque:  
7 lbf·ft (10 N·m, 1.0 kgf·m)

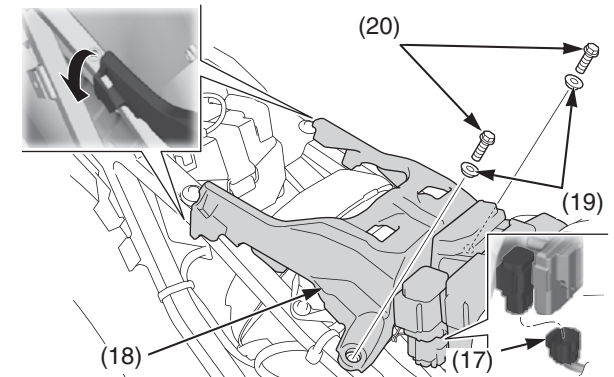

- (17) starter/ignition relay connector
- (18) seat support base
- (19) collars
- (20) seat support base mounting bolts

- Tighten the right and left muffler mounting A bolts, and install the right and left exhaust springs A, (page 133). (CRF450RWE only)
- Install the left and right mufflers (page 127).
- Install the right and left shrouds (page 36, page 38).
- Install the seat (page 34).

# Fuel System (CRF450RX)

Refer to *Important Safety Precautions* on page 23.

## Fuel

Type	Unleaded
Pump Octane Number	91 (or higher)

Use only unleaded fuel in your CRF. If you ride your CRF in a country where leaded fuel might be available, take precautions to use only unleaded fuel.

Your engine is designed to use any unleaded gasoline that has a pump octane number of 91 or higher. Gasoline pumps at service stations normally display the pump octane number. For information on the use of oxygenated fuels, see page 178.

Use of lower octane gasoline can cause persistent “pinging” or “spark knock” (a louder rapping noise) which, if severe, can lead to engine damage. (Light pinging experienced while operating under a heavy load, such as climbing a hill, is no cause for concern.)

If pinging or spark knock occurs at a steady engine speed under normal load, change brands of gasoline. If pinging or spark knock persists, consult your dealer.

Never use stale or contaminated gasoline. Avoid getting dirt, dust or water in the fuel tank.

## Refueling Procedure

1. To open the fuel fill cap (1), pull the breather tube (2) out of the steering stem nut (3). Turn the fuel fill cap counterclockwise and remove it.
2. Add fuel until the level reaches the bottom of the filler neck (4).

Fuel Tank Capacity: 2.25 US gal (8.5 ℓ)

- Be careful not to damage the fuel pump while filling the fuel tank.
- Avoid overfilling the tank. There should be no fuel in the filler neck.

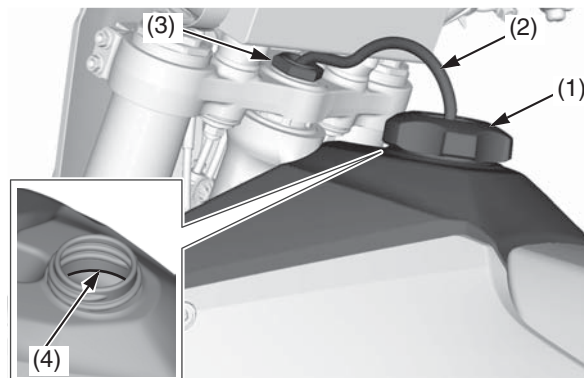

(1) fuel fill cap  
(2) breather tube

(3) steering stem nut  
(4) filler neck bottom

## ⚠ WARNING

Gasoline is highly flammable and explosive. You can be burned or seriously injured when handling fuel.

- Stop the engine and keep heat, sparks and flame away.
- Handle fuel only outdoors.
- Wipe up spills immediately.

3. Close the fuel fill cap and insert the breather tube into the steering stem nut.

## Fuel Line Inspection

1. Hang the fuel tank to the left side of the frame (page 35).
2. Remove the fuel quick connect fitting cover (1).
3. Check the fuel line (2) for cracks, deterioration, damage or leakage. Replace the fuel line, if necessary.

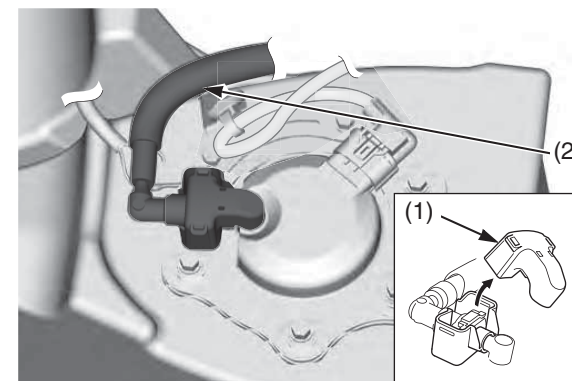

(1) fuel quick connect fitting cover  
(2) fuel line

4. Install the fuel quick connect fitting cover.
5. Install the fuel tank (page 36).

## Fuel Pressure Relieving

1. Hang the fuel tank to the left side of the frame (page 35).
2. Disconnect the fuel pump connector (1).

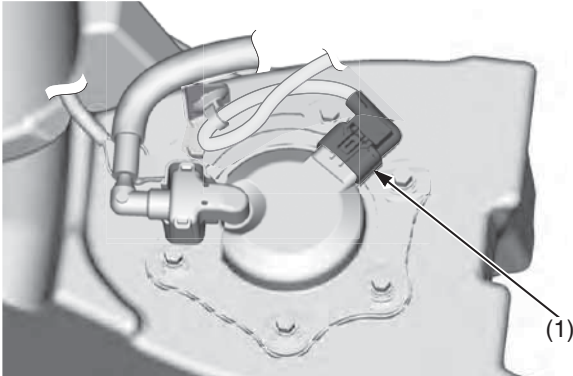

(1) fuel pump connector

3. Reposition the fuel tank and start the engine and let it idle until the engine stalls.

## Fuel Line Replacement

### Disconnection

1. Relieve the fuel pressure (this page).
2. Hang the fuel tank to the left side of the frame.
3. Remove the fuel quick connect fitting cover (1) from the fuel pump (2).
4. Check the fuel quick connect fitting (3) for dirt, and clean if necessary.

Injector side:

Fuel pump side:

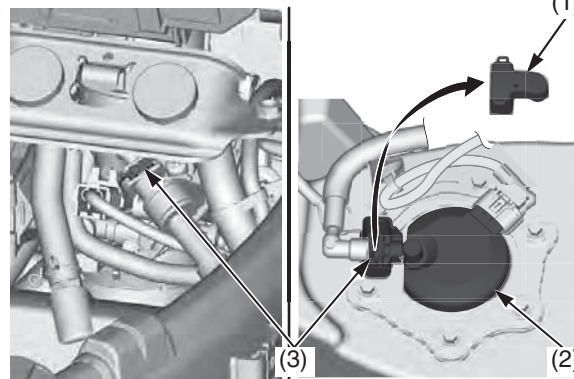

- (1) fuel quick connect fitting cover
- (2) fuel pump
- (3) fuel quick connect fitting

5. Remove the bolt (4), clamp and setting rubber (5).

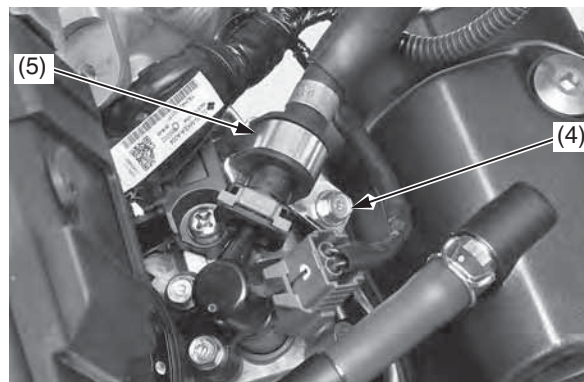

- (4) bolt
- (5) clamp and setting rubber

6. Place a shop towel (6) over the fuel quick connect fitting.

Injector side:

Fuel pump side:

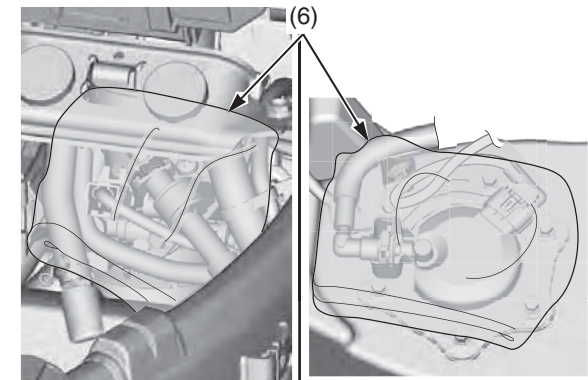

(6) shop towel

(cont'd)



# Fuel System (CRF450RX)

7. Unlock the slide retainer (7) of the quick connect fitting by completely pulling it up. Release the fuel quick connect fitting from the fuel joint (8) while holding the connector housing (9).
- Use a shop towel to absorb the remaining fuel in the fuel feed hose.
  - Be careful not to damage the hose or other parts.
  - Do not use tools.
  - Dirt intruding into the connector housing may cause slide retainer sticking.

## ⚠ WARNING

Gasoline is highly flammable and explosive. You can be burned or seriously injured when handling fuel.

- Stop the engine and keep heat, sparks and flame away.
- Handle fuel only outdoors.
- Wipe up spills immediately.

Injector side:

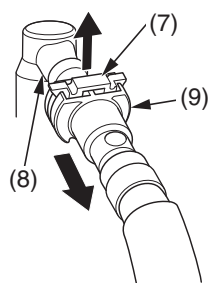

- (7) slide retainer  
(8) fuel joint  
(9) connector housing

Fuel pump side:

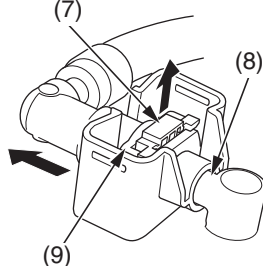

8. Remove the rubber cover (10) from the fuel joint of the fuel pump.

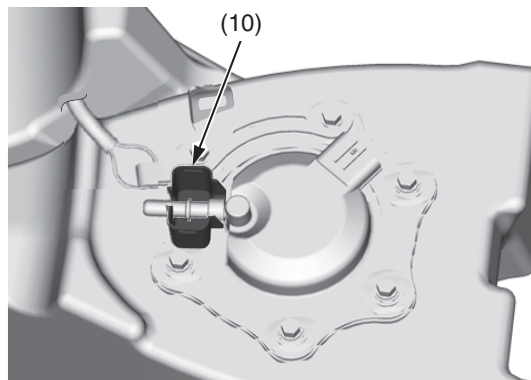

(10) rubber cover

9. To prevent damage and keep foreign matter out, cover the disconnected connector (11) and fuel joint (8) with plastic bags (12).

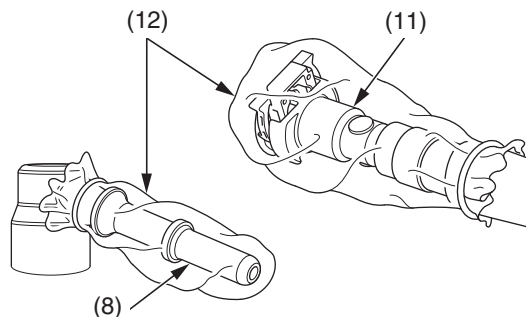

(8) fuel joint  
(11) disconnected connector  
(12) plastic bags

## Connection

1. Install the rubber cover (1) onto the fuel joint (2) of the fuel pump as shown.

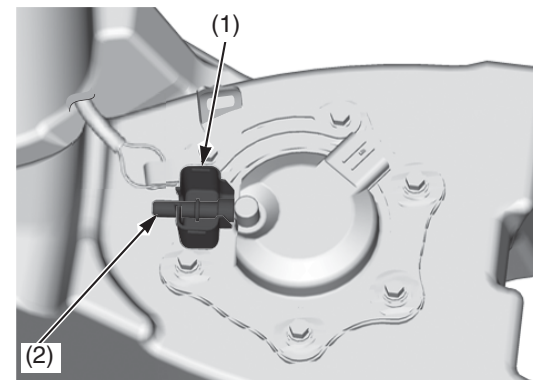

(1) rubber cover  
(2) fuel joint

2. Be sure that the slide retainer (3) is completely pulled up before connecting the quick connect fitting.
- Do not bend or twist the fuel feed hose.
  - Do not reuse the kinked or damaged fuel hose.
  - Do not use gloves or a shop towel while installing the quick connect fitting.

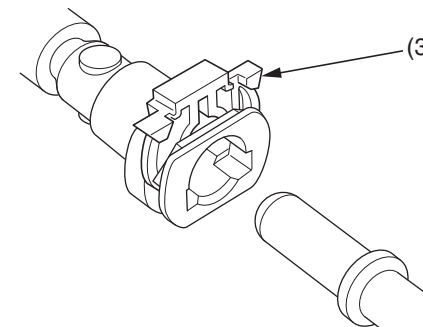

(3) slide retainer

3. Connect the quick connect fitting to the fuel joint (2) until you hear the “click” while holding the connector housing (4). Lock the slide retainer (3) by pushing it until you hear the “click”.

If it is hard to connect, put a small amount of engine oil on the pipe end of the fuel joint.

Injector side:

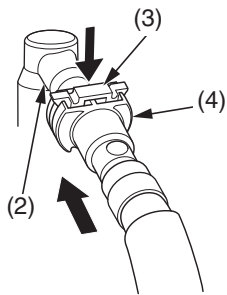

Fuel pump side:

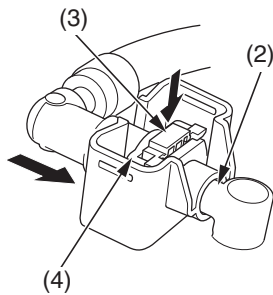

- (2) fuel joint
- (3) slide retainer
- (4) connector housing

4. Make sure the connection is secure and that the slide retainer is firmly locked into place; check visually and by pulling the connector housing.

5. Install the setting rubber (5), clamp (6) and bolt (7) by aligning the clamp tab (8) with the groove (9) of the stay. Tighten the bolt securely.

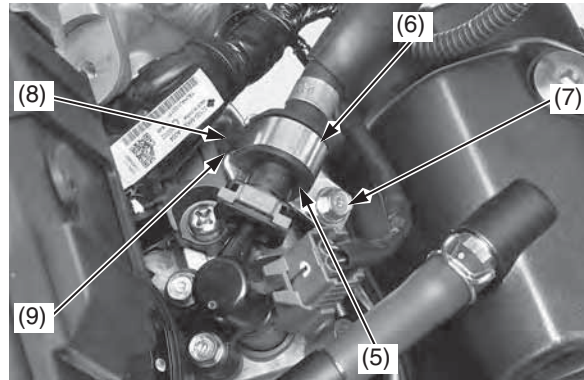

- (5) setting rubber
- (6) clamp
- (7) bolt
- (8) clamp tab
- (9) groove

6. Install the fuel quick connect fitting cover (10).

Be sure the rubber cover (1) is properly installed between the fuel quick connect fitting cover and fuel pump.

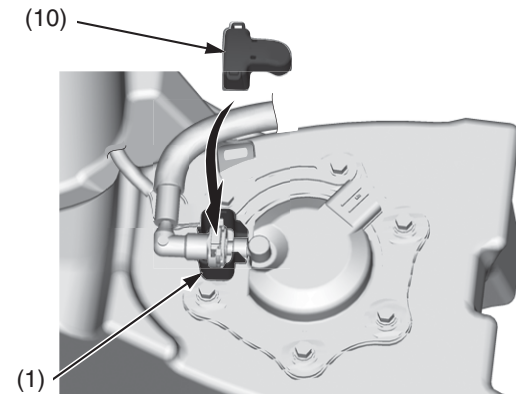

- (1) rubber cover
- (10) fuel quick connect fitting cover

7. Increase the fuel pressure (page 51).

# Fuel System (CRF450RX)

## Fuel Pump Filter Replacement

Empty the fuel tank by transferring fuel into an approved gasoline container using a commercially available hand siphon or an equivalent method. Be careful not to damage the fuel pump while draining the fuel in the fuel tank.

### **⚠ WARNING**

Gasoline is highly flammable and explosive. You can be burned or seriously injured when handling fuel.

- Stop the engine and keep heat, sparks and flame away.
- Handle fuel only outdoors.
- Wipe up spills immediately.

### Removal

1. Relieve the fuel pressure (page 43).
2. Disconnect the fuel line from the fuel pump (page 43).
3. Remove the fuel tank (1) by releasing the stopper cable (2) from the hook (3) of the frame.
4. Pull the harness band clip (4) while pressing both side of the anchor and disconnect it.

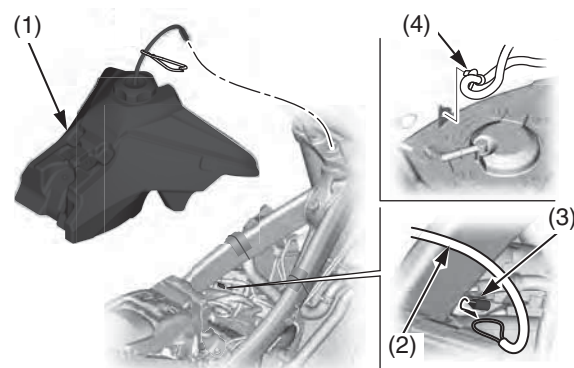

(1) fuel tank  
(2) stopper cable

(3) frame hook  
(4) harness band clip

5. Remove the fuel pump mounting bolts (5), stopper cable guide (6), stopper cable (2), washers (7), collars (8), conical spring washers (9) and fuel pump plate (10) while holding the fuel tank.

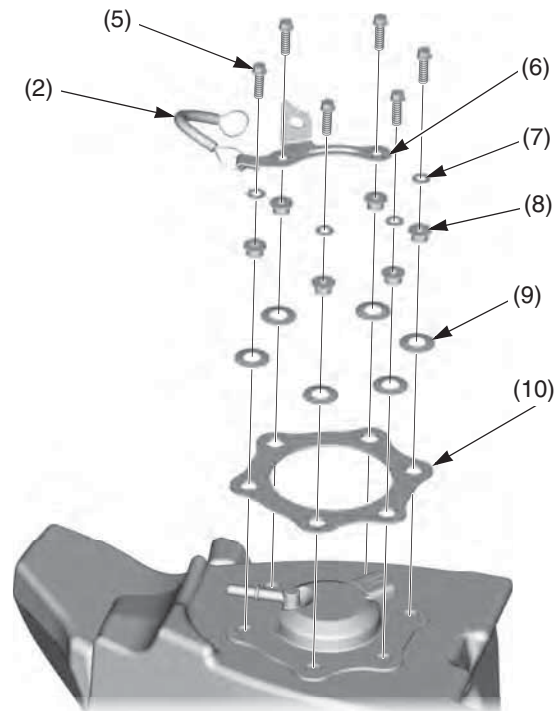

(2) stopper cable  
(5) fuel pump mounting bolts  
(6) stopper cable guide  
(7) washers  
(8) collars  
(9) conical spring washers  
(10) fuel pump plate

6. Remove the fuel pump unit (11) and O-rings (12).

Be careful not to damage the fuel pump unit.

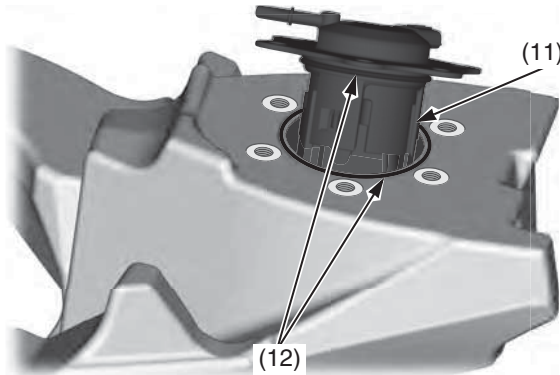

(11) fuel pump unit  
(12) O-rings

7. Disconnect the fuel pump wire terminals (13) from the fuel pump base (14).

Be careful not to damage the wires when disconnecting the fuel pump wire terminals.

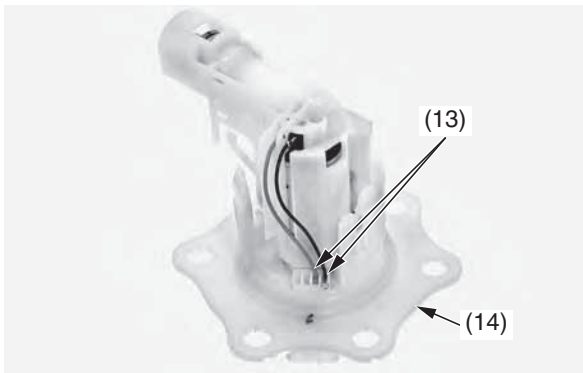

(13) fuel pump wire terminals  
(14) fuel pump base

8. Check the hooks (15) of the fuel pump unit holder and tabs (16) on the fuel pump base for damage or discoloration. If the hooks and tabs are damaged or discolored, replace the fuel pump unit as an assembly.
9. Release the hooks of the fuel pump unit holder from the grooves (17) in the fuel pump base tabs while pushing the holder against the base and slightly spreading the base tabs.

Be careful not to damage the hooks and tabs.

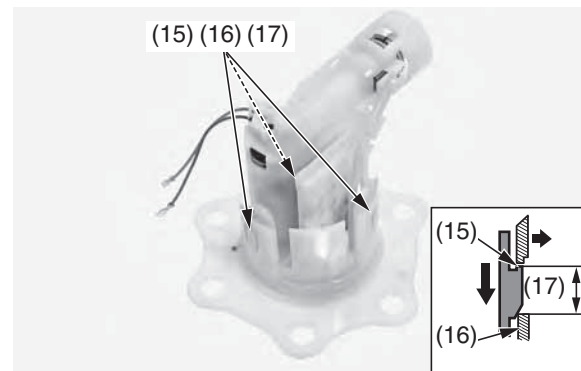

(15) hooks  
(16) tabs

(17) grooves

10. Remove the fuel pump unit holder assembly (18) from the fuel pump base (14) and remove the O-ring (19).

Wipe the spilled out fuel immediately.

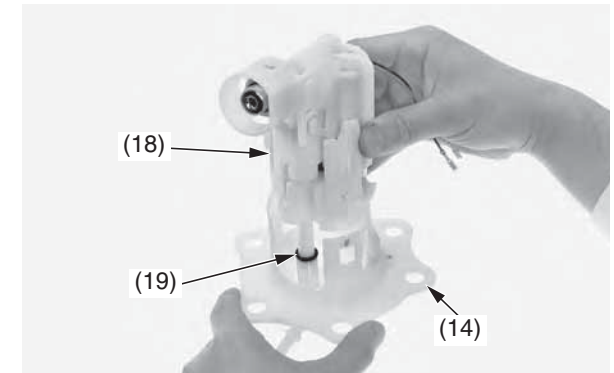

(14) fuel pump base  
(18) fuel pump unit holder assembly  
(19) O-ring

11. Remove the fuel pump stopper (20) and damper rubber (21).

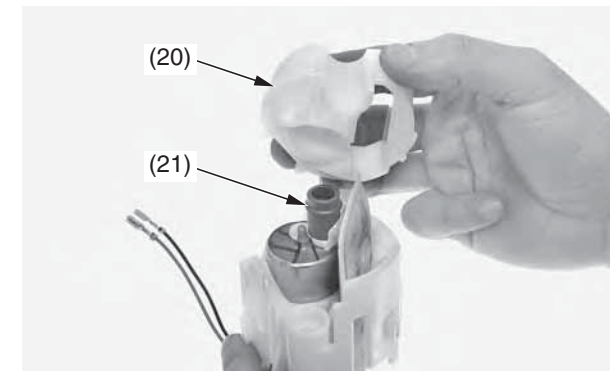

(20) fuel pump stopper  
(21) damper rubber

(cont'd)



# Fuel System (CRF450RX)

12. Remove the fuel pump assembly (22) with fuel pump filter (23), O-ring (24) from the fuel pump unit holder (25).

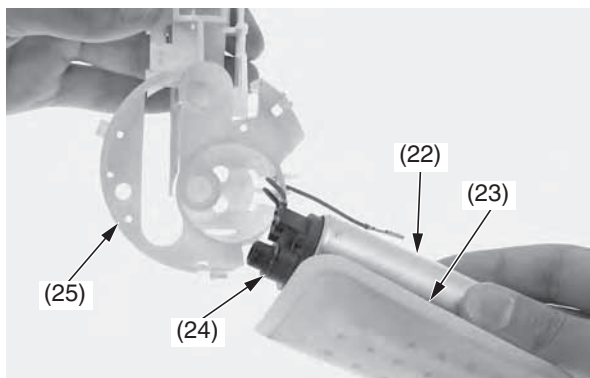

(22) fuel pump assembly  
(23) fuel pump filter  
(24) O-ring  
(25) fuel pump unit holder

13. Check the fuel pump filter (23) for clog, damage or deterioration and replace it if necessary.  
14. Remove the fuel pump filter from the fuel pump assembly (22).

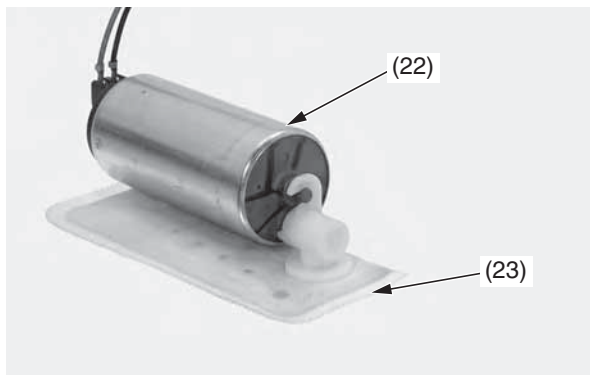

(22) fuel pump assembly  
(23) fuel pump filter

## Installation

1. Install the fuel pump filter (1) onto the fuel pump assembly (2) aligning its hook (3) with the joint boss (4) completely.

Be careful not to damage the hook.

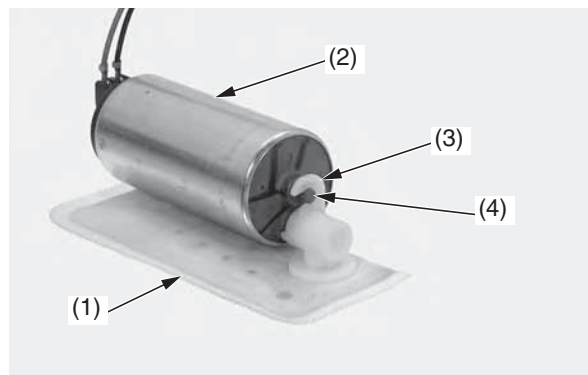

(1) fuel pump filter      (3) hook  
(2) fuel pump assembly      (4) joint boss

2. Apply small amount of engine oil to a new O-ring (5).  
Install a new O-ring to the fuel pump assembly (2).  
3. Install the fuel pump assembly with fuel pump filter into the fuel pump unit holder (6) while routing the fuel pump red (7) and black (8) wires through the holder grooves (9) as shown.

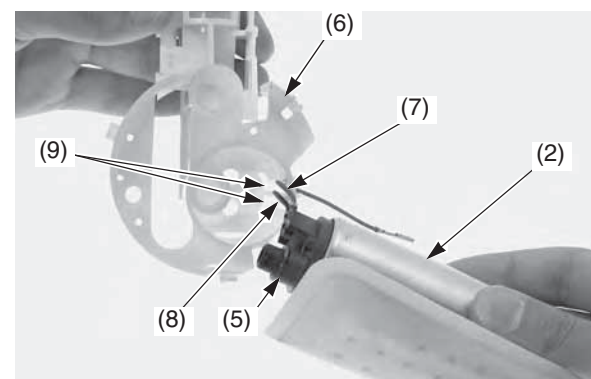

(2) fuel pump assembly      (7) red wire  
(5) O-ring (new)      (8) black wire  
(6) fuel pump unit holder      (9) grooves

4. Install a new damper rubber (10) to the fuel pump assembly as shown.  
Install fuel pump stopper (11).

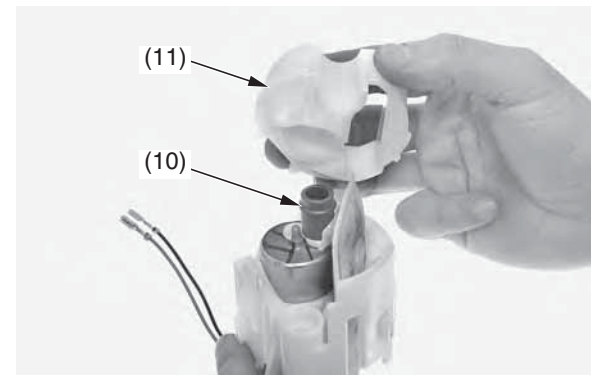

(10) damper rubber (new)      (11) fuel pump stopper

5. Apply small amount of engine oil to a new O-ring (12).  
Install a new O-ring to the fuel pump base (13).
6. Install the fuel pump unit holder assembly (14) into the fuel pump base while aligning its hooks (15) with the grooves (16) in the fuel pump base tabs (17).  
If the gap between the hooks and tabs is more than 0.04 in (1.0 mm), replace the fuel pump unit.

Be sure that the hooks are completely seated.

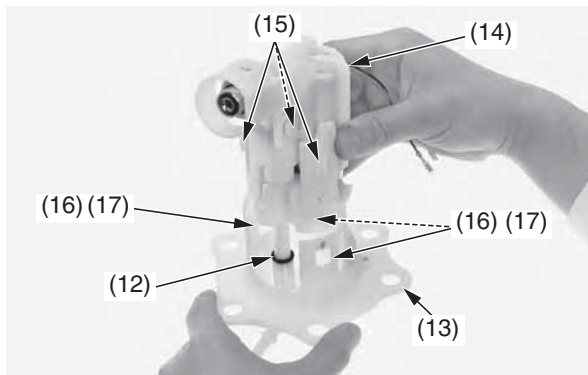

- (12) O-ring (new)
- (13) fuel pump base
- (14) fuel pump unit holder assembly
- (15) hooks
- (16) grooves
- (17) tabs

7. Connect the fuel pump red (18) and black (19) wire terminals to the fuel pump base terminals (20). Push the wire terminals until they stop as shown.

Be careful not to damage the wires.

8. Apply 0.02 oz (0.5 g) maximum of engine oil to a new O-ring (21).  
Install a new O-ring onto the fuel pump unit (22).

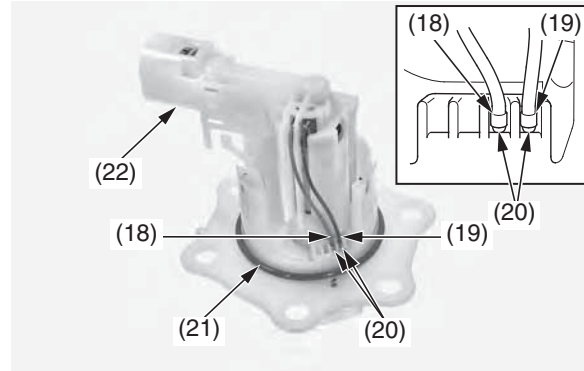

- (18) red wire terminal
- (19) black wire terminal
- (20) fuel pump base terminals
- (21) O-ring (new)
- (22) fuel pump unit

9. Apply small amount of engine oil to a new O-ring (23).  
Install a new O-ring into the fuel tank groove.
10. Install the fuel pump unit (22) into the fuel tank (24) with its hose joint facing forward.

Be careful not to damage the fuel pump unit.

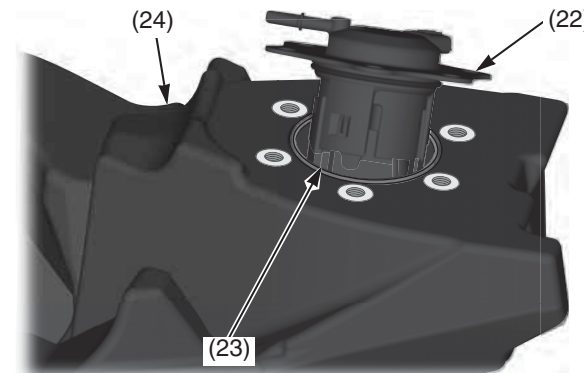

- (22) fuel pump unit
- (23) O-ring (new)
- (24) fuel tank

11. Install the fuel pump plate (25) with its identification mark (26) facing forward the front side and facing up.

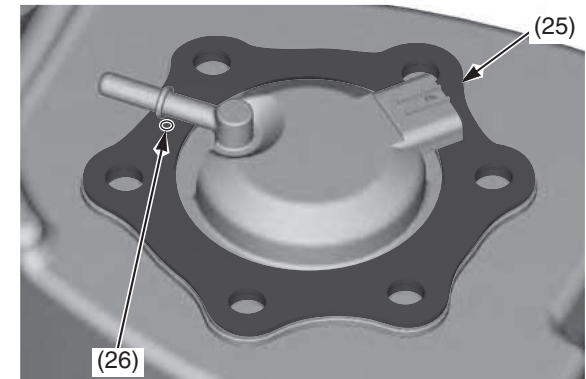

- (25) fuel pump plate
- (26) identification mark

(cont'd)

## Fuel System (CRF450RX)

12. Install the conical spring washers (27), collars (28), washers (29), stopper cable (30), stopper cable guide (31) and fuel pump mounting bolts (32).

Make sure that the convex surfaces of the conical spring washers are up side.

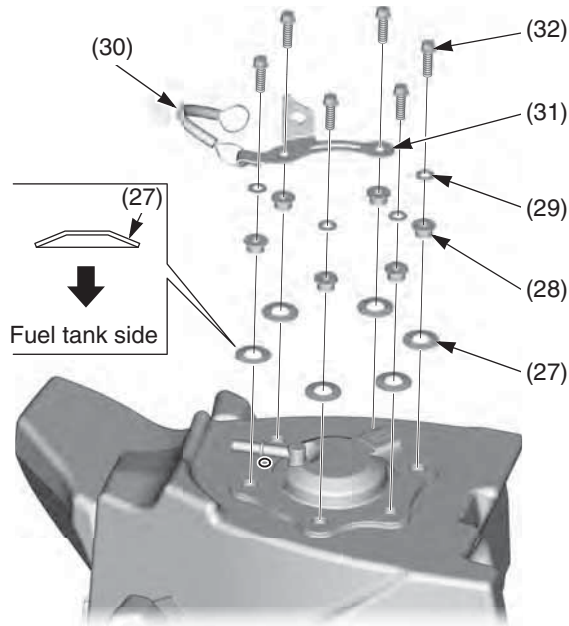

- (27) conical spring washers
- (28) collars
- (29) washers
- (30) stopper cable
- (31) stopper cable guide
- (32) fuel pump mounting bolts

13. Tighten the fuel pump mounting bolts (32) to the specified torque in the specified sequence as shown:  
8 lbf-ft (11 N·m, 1.1 kgf·m)

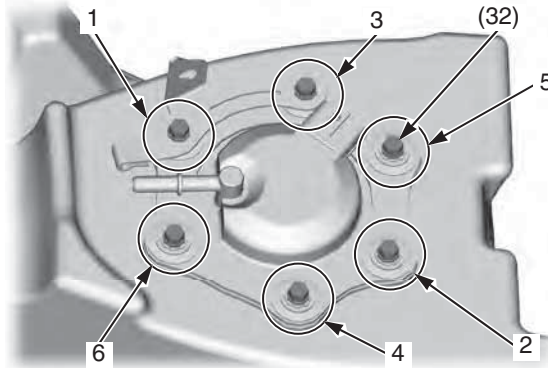

(32) fuel pump mounting bolts

14. Install the harness band clip (33) to the stopper cable guide (31).  
15. Install the stopper cable (30) to the hook (34) of the frame while holding the fuel tank (24).

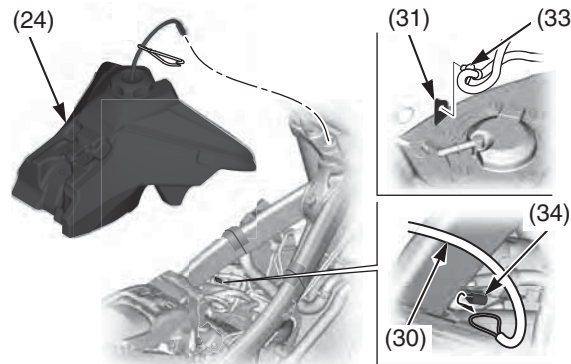

- (24) fuel tank
- (30) stopper cable
- (31) stopper cable guide
- (33) harness band clip
- (34) hook

16. Connect the fuel line (page 44).  
17. Increase the fuel pressure (page 51).

### Fuel Pressure Increasing

Make sure enough fuel remains (0.3 US gal (1.0 ℓ) minimum) in the fuel tank and add fuel if necessary before increasing fuel pressure.

With the throttle closed.

Pull the clutch lever all the way in, and depress the start button.

The engine will start up with increasing the fuel pressure.

If the engine does not start, check all connector connections and/or refer to an official Honda Service Manual (page 186) for troubleshooting of the PGM-FI symptom.

# Fuel System (CRF450R/RWE)

Refer to *Important Safety Precautions* on page 23.

## Fuel

Type	Unleaded
Pump Octane Number	91 (or higher)

Use only unleaded fuel in your CRF. If you ride your CRF in a country where leaded fuel might be available, take precautions to use only unleaded fuel.

Your engine is designed to use any unleaded gasoline that has a pump octane number of 91 or higher. Gasoline pumps at service stations normally display the pump octane number. For information on the use of oxygenated fuels, see page 178.

Use of lower octane gasoline can cause persistent “pinging” or “spark knock” (a louder rapping noise) which, if severe, can lead to engine damage. (Light pinging experienced while operating under a heavy load, such as climbing a hill, is no cause for concern.)

If pinging or spark knock occurs at a steady engine speed under normal load, change brands of gasoline. If pinging or spark knock persists, consult your dealer.

Never use stale or contaminated gasoline. Avoid getting dirt, dust or water in the fuel tank.

## Refueling Procedure

1. To open the fuel fill cap (1), pull the breather tube (2) out of the steering stem nut (3). Turn the fuel fill cap counterclockwise and remove it.
2. Add fuel until the level reaches the bottom of the filler neck (4).

Fuel Tank Capacity: 1.66 US gal (6.3 ℓ)

- Be careful not to damage the fuel pump while filling the fuel tank.
- Avoid overfilling the tank. There should be no fuel in the filler neck.

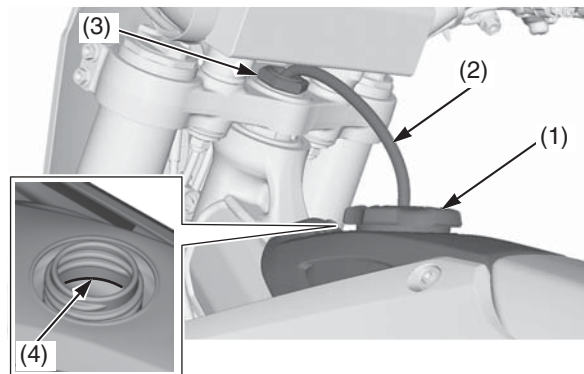

(1) fuel fill cap  
(2) breather tube

(3) steering stem nut  
(4) filler neck bottom

## ⚠ WARNING

Gasoline is highly flammable and explosive. You can be burned or seriously injured when handling fuel.

- Stop the engine and keep heat, sparks and flame away.
- Handle fuel only outdoors.
- Wipe up spills immediately.

3. Close the fuel fill cap and insert the breather tube into the steering stem nut.

## Fuel Line Inspection

1. Hang the fuel tank to the left side of the frame (page 35).
2. Remove the fuel quick connect fitting cover (1).
3. Check the fuel line (2) for cracks, deterioration, damage or leakage. Replace the fuel line, if necessary.

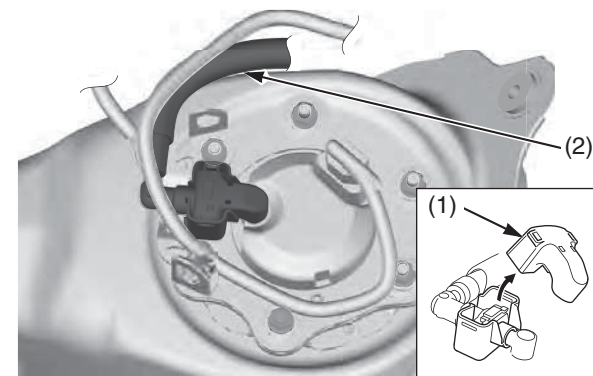

(1) fuel quick connect fitting cover  
(2) fuel line

4. Install the fuel quick connect fitting cover.
5. Install the fuel tank (page 36).



## Fuel Pressure Relieving

1. Hang the fuel tank to the left side of the frame (page 37).
2. Disconnect the fuel pump connector (1).

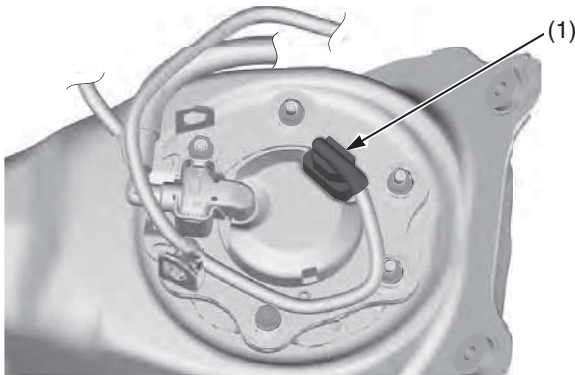

(1) fuel pump connector

3. Reposition the fuel tank and start the engine and let it idle until the engine stalls.

## Fuel Line Replacement

### Disconnection

1. Relieve the fuel pressure (this page).
2. Hang the fuel tank to the left side of the frame.
3. Remove the fuel quick connect fitting cover (1) from the fuel pump (2).
4. Check the fuel quick connect fitting (3) for dirt, and clean if necessary.

Injector side:

Fuel pump side:

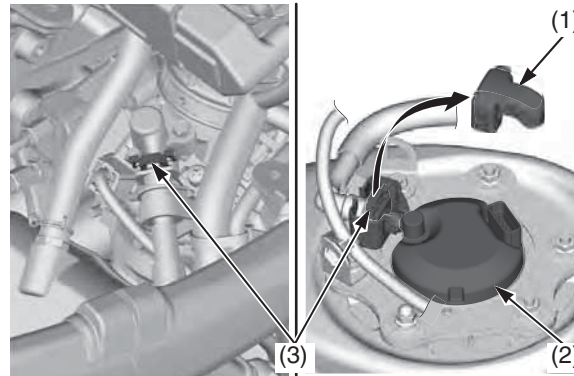

- (1) fuel quick connect fitting cover
- (2) fuel pump
- (3) fuel quick connect fitting

5. Remove the bolt (4), clamp and setting rubber (5).

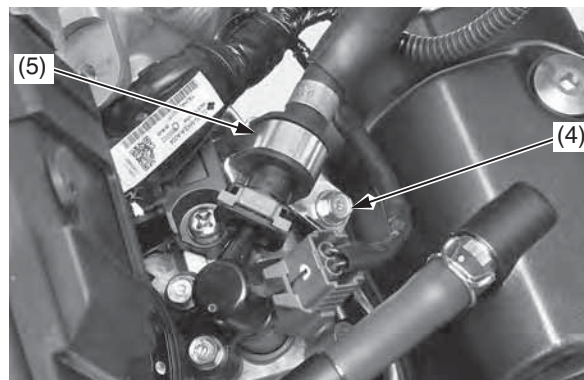

- (4) bolt
- (5) clamp and setting rubber

6. Place a shop towel (6) over the fuel quick connect fitting.

Injector side:

Fuel pump side:

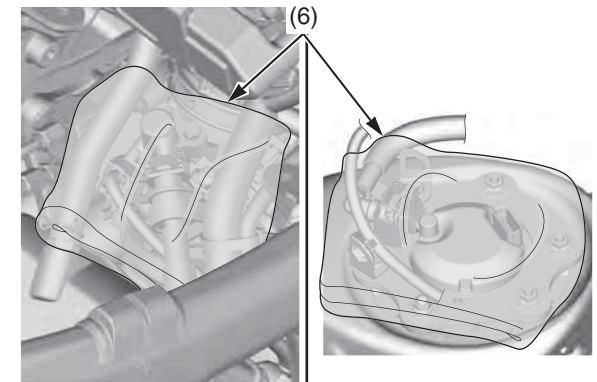

(6) shop towel

(cont'd)

# Fuel System (CRF450R/RWE)

7. Unlock the slide retainer (7) of the quick connect fitting by completely pulling it up. Release the fuel quick connect fitting from the fuel joint (8) while holding the connector housing (9).
- Use a shop towel to absorb the remaining fuel in the fuel feed hose.
  - Be careful not to damage the hose or other parts.
  - Do not use tools.
  - Dirt intruding into the connector housing may cause slide retainer sticking.

## ⚠ WARNING

Gasoline is highly flammable and explosive. You can be burned or seriously injured when handling fuel.

- Stop the engine and keep heat, sparks and flame away.
- Handle fuel only outdoors.
- Wipe up spills immediately.

Injector side:

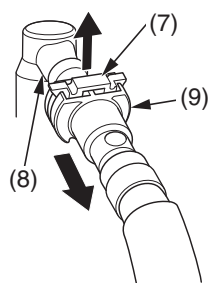

- (7) slide retainer  
(8) fuel joint  
(9) connector housing

Fuel pump side:

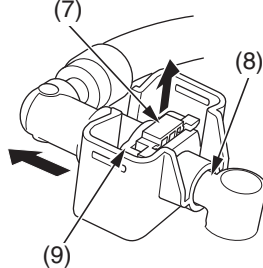

8. Remove the rubber cover (10) from the fuel joint of the fuel pump.



(10) rubber cover

9. To prevent damage and keep foreign matter out, cover the disconnected connector (11) and fuel joint (8) with plastic bags (12).

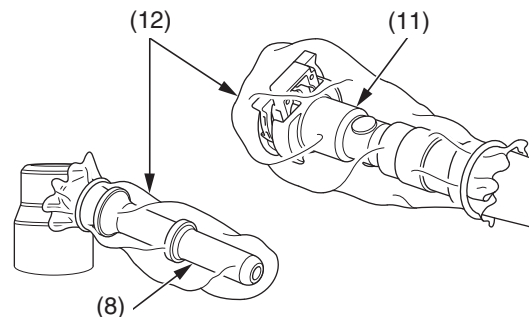

(8) fuel joint  
(11) disconnected connector  
(12) plastic bags

## Connection

1. Install the rubber cover (1) onto the fuel joint (2) of the fuel pump as shown.

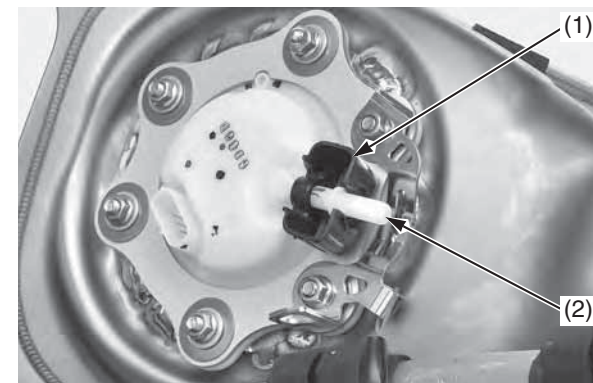

(1) rubber cover  
(2) fuel joint

2. Be sure that the slide retainer (3) is completely pulled up before connecting the quick connect fitting.
- Do not bend or twist the fuel feed hose.
  - Do not reuse the kinked or damaged fuel hose.
  - Do not use gloves or a shop towel while installing the quick connect fitting.

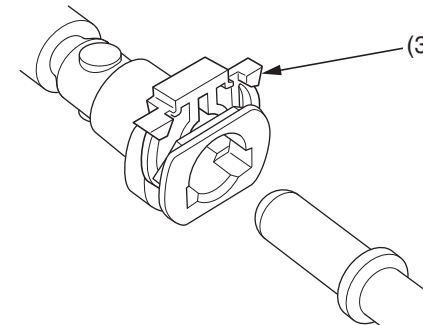

(3) slide retainer

3. Connect the quick connect fitting to the fuel joint (2) until you hear the “click” while holding the connector housing (4). Lock the slide retainer (3) by pushing it until you hear the “click”.

If it is hard to connect, put a small amount of engine oil on the pipe end of the fuel joint.

Injector side:

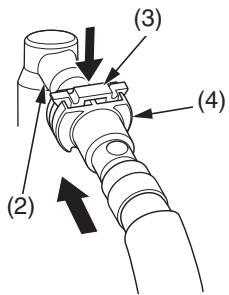

Fuel pump side:

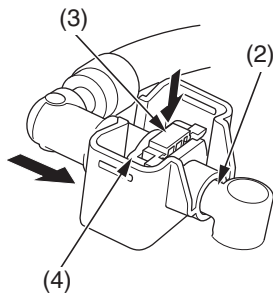

- (2) fuel joint
- (3) slide retainer
- (4) connector housing

4. Make sure the connection is secure and that the slide retainer is firmly locked into place; check visually and by pulling the connector housing.

5. Install the setting rubber (5), clamp (6) and bolt (7) by aligning the clamp tab (8) with the groove (9) of the stay. Tighten the bolt securely.

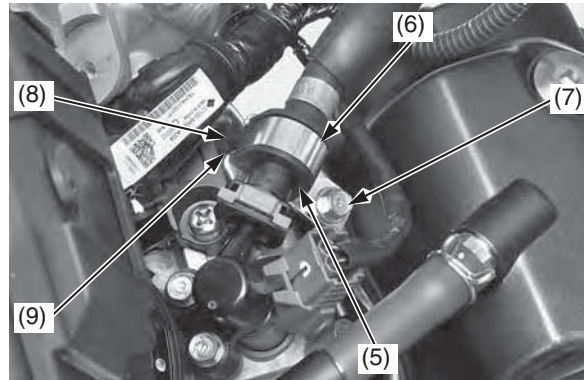

- (5) setting rubber
- (6) clamp
- (7) bolt
- (8) clamp tab
- (9) groove

6. Install the fuel quick connect fitting cover (10).

Be sure the rubber cover (1) is properly installed between the fuel quick connect fitting cover and fuel pump.

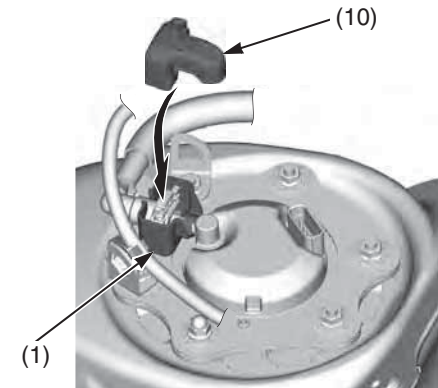

- (1) rubber cover
- (10) fuel quick connect fitting cover

7. Increase the fuel pressure (page 61).



# Fuel System (CRF450R/RWE)

## Fuel Pump Filter Replacement

Empty the fuel tank by transferring fuel into an approved gasoline container using a commercially available hand siphon or an equivalent method. Be careful not to damage the fuel pump while draining the fuel in the fuel tank.

### **⚠ WARNING**

Gasoline is highly flammable and explosive. You can be burned or seriously injured when handling fuel.

- Stop the engine and keep heat, sparks and flame away.
- Handle fuel only outdoors.
- Wipe up spills immediately.

### Removal

1. Relieve the fuel pressure (page 53).
2. Disconnect the fuel line from the fuel pump (page 53).
3. Remove the fuel tank (1) by releasing the stopper cable (2) from the hook (3) of the frame.
4. Pull the harness band clip (4) while pressing both side of the anchor and disconnect it.

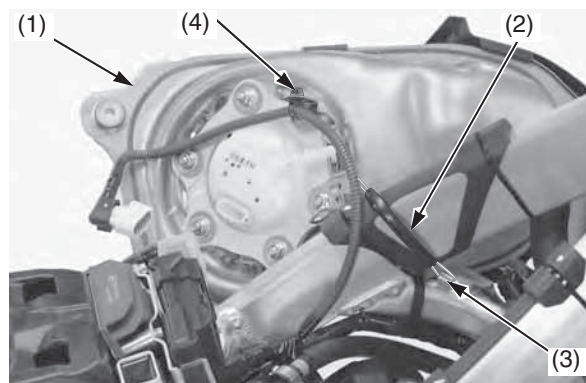

(1) fuel tank  
(2) stopper cable

(3) frame hook  
(4) harness band clip

5. Remove the fuel pump mounting nuts (5), fuel pump mounting cap nut (6), stopper cable guide (7), stopper cable (2), washer (8), collars (9), conical spring washers (10) and fuel pump plate (11) while holding the fuel tank.

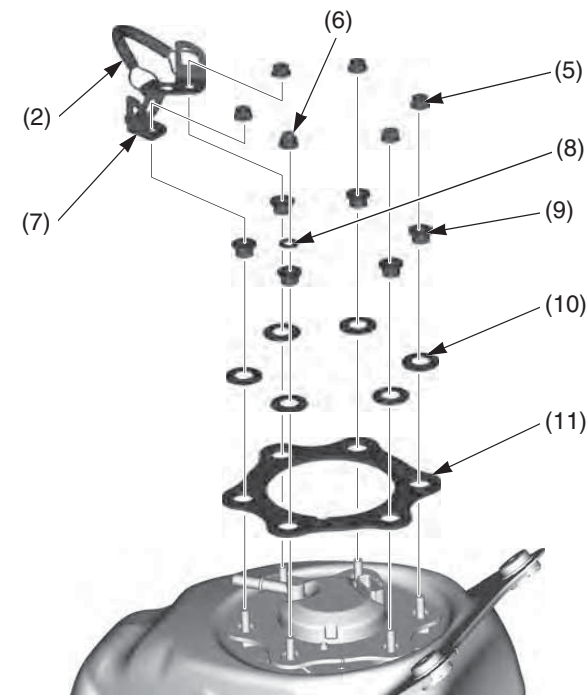

(2) stopper cable  
(5) fuel pump mounting nuts  
(6) fuel pump mounting cap nut  
(7) stopper cable guide  
(8) washer  
(9) collars  
(10) conical spring washers  
(11) fuel pump plate

6. Remove the fuel pump unit (12), dust seal (13) and O-ring (14).

Be careful not to damage the fuel pump unit.

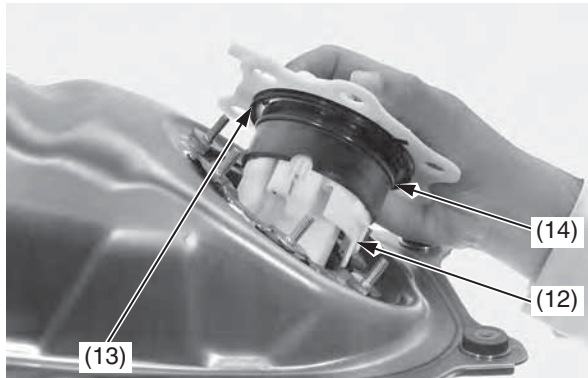

(12) fuel pump unit  
(13) dust seal  
(14) O-ring

7. Disconnect the fuel pump wire terminals (15) from the fuel pump base (16).

Be careful not to damage the wires when disconnecting the fuel pump wire terminals.

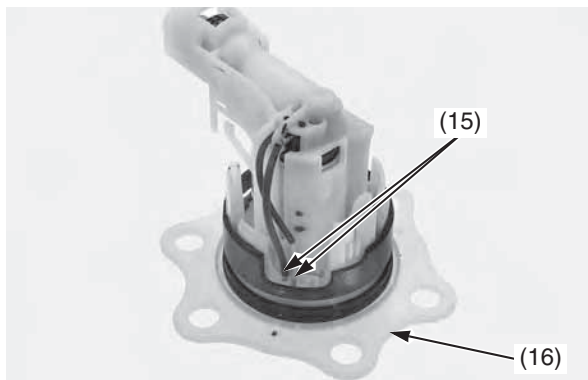

(15) fuel pump wire terminals  
(16) fuel pump base

8. Check the hooks (17) of the fuel pump unit holder and tabs (18) on the fuel pump base for damage or discoloration. If the hooks and tabs are damaged or discolored, replace the fuel pump unit as an assembly.
9. Release the hooks of the fuel pump unit holder from the grooves (19) in the fuel pump base tabs while pushing the holder against the base and slightly spreading the base tabs.

Be careful not to damage the hooks and tabs.

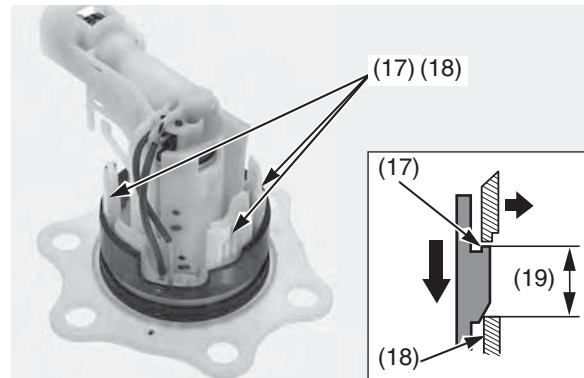

(17) hooks  
(18) tabs

(19) grooves

10. Remove the fuel pump unit holder assembly (20) from the fuel pump base (16) and remove the O-ring (21).

Wipe the spilled out fuel immediately.

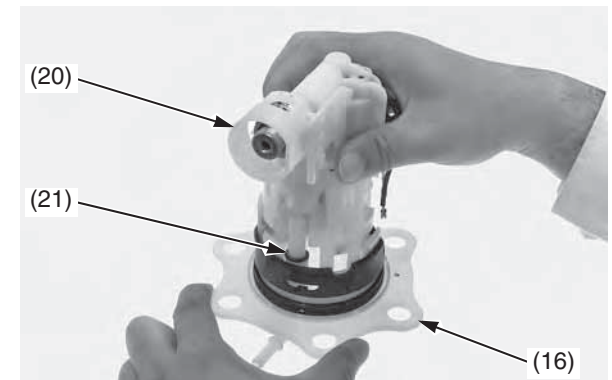

(16) fuel pump base  
(20) fuel pump unit holder assembly  
(21) O-ring

11. Remove the fuel pump stopper (22) and damper rubber (23).

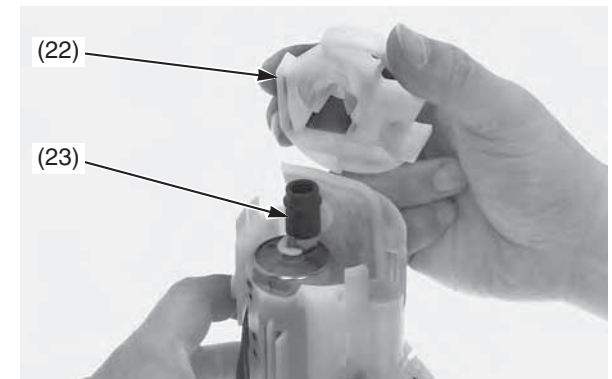

(22) fuel pump stopper  
(23) damper rubber

(cont'd)

## Fuel System (CRF450R/RWE)

12. Remove the fuel pump assembly (24) from the fuel pump unit holder (25).
13. Remove the O-ring (26) from the fuel pump assembly.

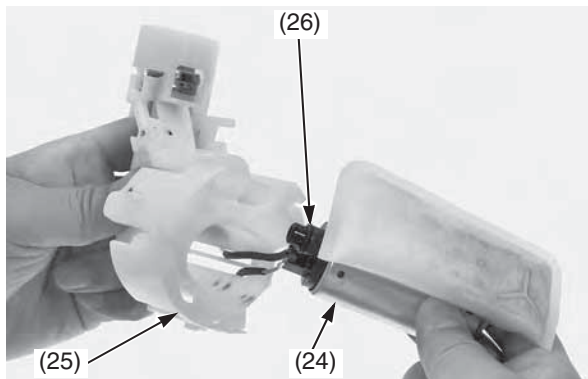

(24) fuel pump assembly  
(25) fuel pump unit holder  
(26) O-ring

14. Remove the fuel pump filter (27) from the fuel pump assembly (24).
15. Check the fuel pump filter for clog, damage or deterioration and replace it if necessary.

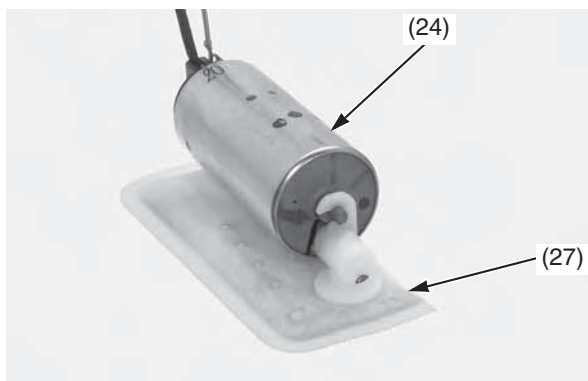

(24) fuel pump assembly  
(27) fuel pump filter

### Installation

1. Install the fuel pump filter (1) onto the fuel pump assembly (2) aligning its hook (3) with the joint boss (4) completely.

Be careful not to damage the hook.

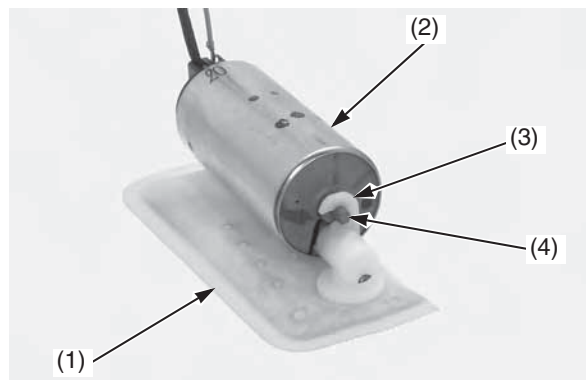

(1) fuel pump filter                      (3) hook  
(2) fuel pump assembly                (4) joint boss

2. Apply small amount of engine oil to a new O-ring (5). Install a new O-ring to the fuel pump assembly (2).
3. Install the fuel pump assembly with fuel pump filter into the fuel pump unit holder (6) while routing the fuel pump yellow (7) and green (8) wires through the holder grooves (9) as shown.

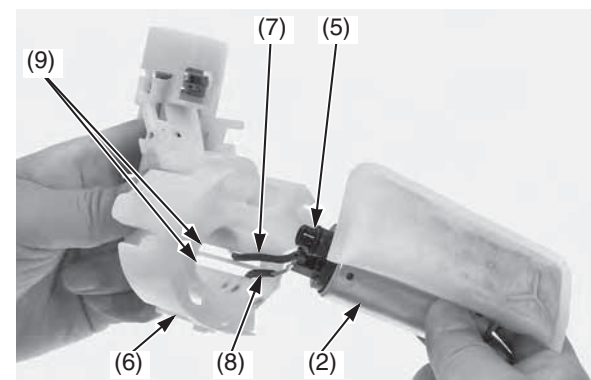

(2) fuel pump assembly                (7) yellow wire  
(5) O-ring (new)                        (8) green wire  
(6) fuel pump unit holder                (9) grooves

4. Install a new damper rubber (10) to the fuel pump assembly as shown. Install fuel pump stopper (11).

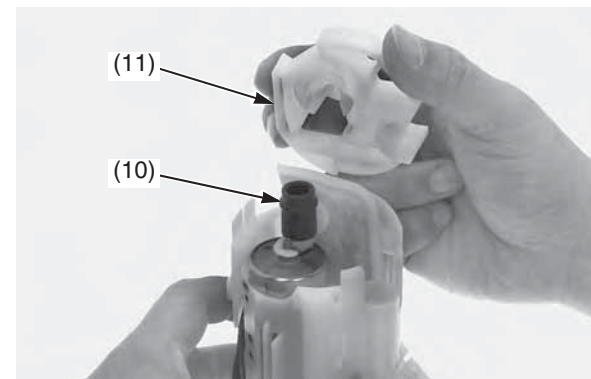

(10) damper rubber (new)  
(11) fuel pump stopper

## Fuel System (CRF450R/RWE)

- Apply small amount of engine oil to a new O-ring (12).  
Install a new O-ring to the fuel pump base (13).
- Install the fuel pump unit holder assembly (14) into the fuel pump base while aligning its hooks (15) with the grooves (16) in the fuel pump base tabs (17).  
If the gap between the hooks and tabs is more than 0.04 in (1.0 mm), replace the fuel pump unit.

Be sure that the hooks are completely seated.

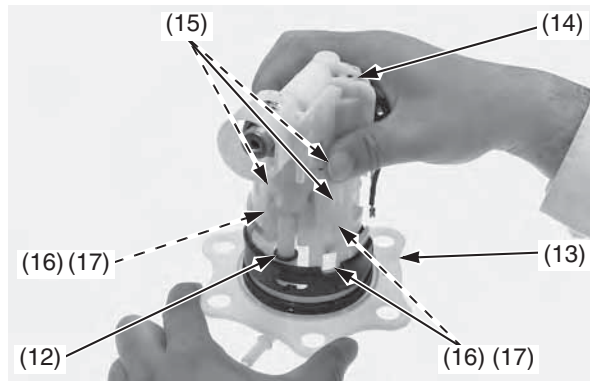

- (12) O-ring (new)
- (13) fuel pump base
- (14) fuel pump unit holder assembly
- (15) hooks
- (16) grooves
- (17) tabs

- Connect the fuel pump yellow (18) and green (19) wire terminals to the fuel pump base terminals (20). Push the wire terminals until they stop as shown.

Be careful not to damage the wires.

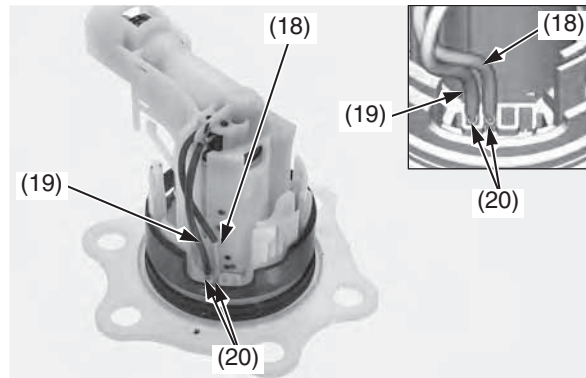

- (18) yellow wire terminal
- (19) green wire terminal
- (20) fuel pump base terminals

- Install a new dust seal (21) by aligning its tabs (22) with the fuel pump unit grooves (23).

Check the dust seal lug (24) which is located the index mark (25) of the fuel pump base (13).

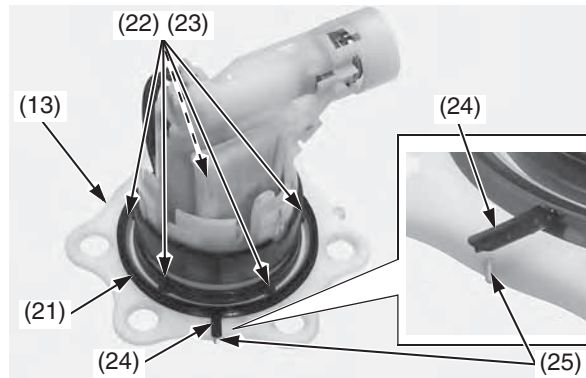

- (13) fuel pump base
- (21) dust seal (new)
- (22) tabs
- (23) grooves
- (24) dust seal lug
- (25) index mark

- Apply small amount of engine oil to a new O-ring (26).  
Install a new O-ring into the between the collar A (27) and collar B (28) of the fuel pump unit (29).



- (26) O-ring (new)
- (27) collar A
- (28) collar B
- (29) fuel pump unit

- Install the fuel pump unit (29) into the fuel tank (30) with its hose joint facing forward.

Be careful not to damage the fuel pump unit.

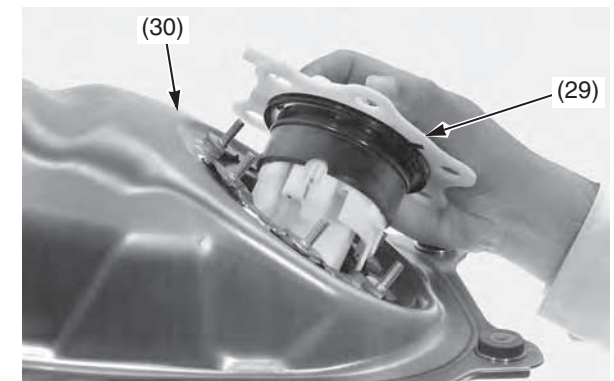

- (29) fuel pump unit
- (30) fuel tank

(cont'd)



## Fuel System (CRF450R/RWE)

11. Install the fuel pump plate (31) by aligning with its groove (32) with fuel pump unit lug (33).

Check the dust seal lug (24) is in position as shown.

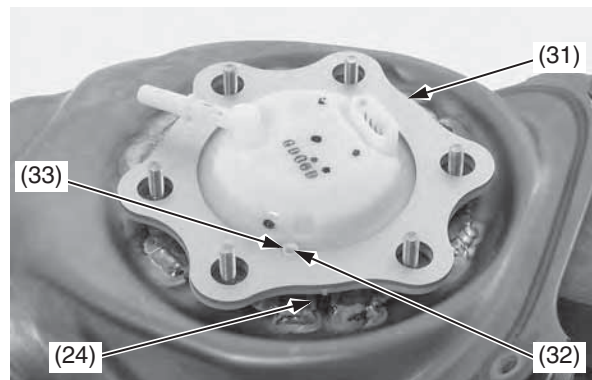

- (24) dust seal lug  
 (31) fuel pump plate  
 (32) fuel pump plate groove  
 (33) fuel pump unit lug

12. Install the conical spring washers (34), collars (35), washer (36), stopper cable (37), stopper cable guide (38), fuel pump mounting nuts (39) and fuel pump mounting cap nut (40).

Make sure that the convex surfaces of the conical spring washers are upside.

Make sure that the cap nut is in position of the identification mark (41) on the fuel pump plate (31).

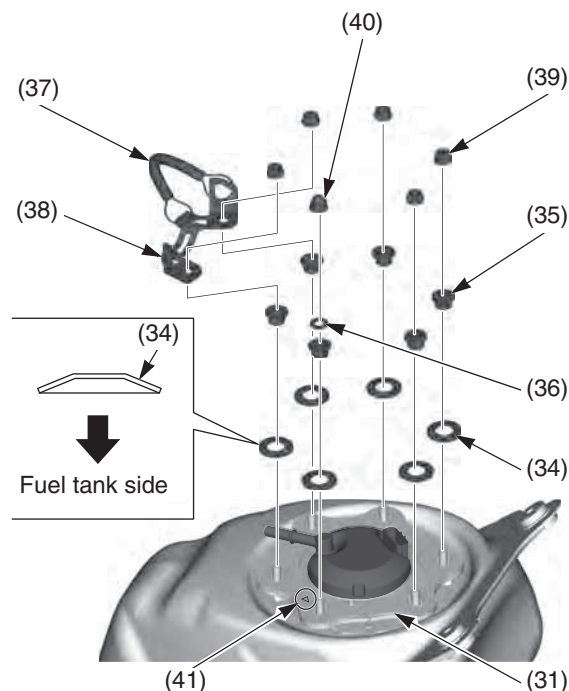

- (31) fuel pump plate  
 (34) conical spring washers  
 (35) collars  
 (36) washer  
 (37) stopper cable  
 (38) stopper cable guide  
 (39) fuel pump mounting nuts  
 (40) fuel pump mounting cap nut  
 (41) identification mark

13. Tighten the fuel pump mounting nuts (39) and cap nut (40) to the specified torque in the specified sequence as shown:  
 8 lbf-ft (11 N·m, 1.1 kgf-m)

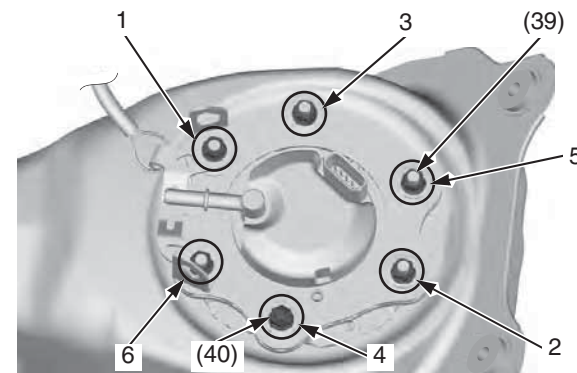

- (39) fuel pump mounting nuts  
 (40) fuel pump mounting cap nut

14. Install the harness band clip (42) to the stopper cable guide (38).  
 15. Install the stopper cable (37) to the hook (43) of the frame while holding the fuel tank (30).

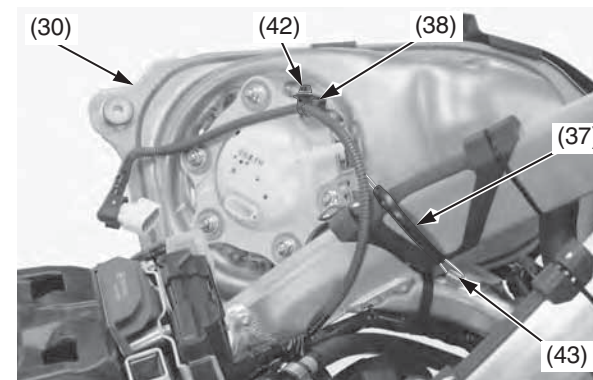

- (30) fuel tank  
 (37) stopper cable  
 (38) stopper cable guide  
 (42) harness band clip  
 (43) hook

16. Connect the fuel line (page 54).  
 17. Increase the fuel pressure (page 61).

### Fuel Pressure Increasing

Make sure enough fuel remains (0.3 US gal (1.0 ℓ) minimum) in the fuel tank and add fuel if necessary before increasing fuel pressure.

With the throttle closed.

Pull the clutch lever all the way in, and depress the start button.

The engine will start up with increasing the fuel pressure.

If the engine does not start, check all connector connections and/or refer to an official Honda Service Manual (page 186) for troubleshooting of the PGM-FI symptom.



# Engine Oil

Refer to *Important Safety Precautions* on page 23.

Using the proper oil, and regularly checking, adding, and changing oil will help extend the service life of the engine. Even the best oil wears out. Changing oil helps get rid of dirt and deposits. Operating the engine with old or dirty oil can damage your engine. Running the engine with insufficient oil can cause serious damage to the engine.

## Oil Recommendation

API classification	SG or higher except oils labeled as energy conserving or resource conserving on the circular API service label
viscosity (weight)	SAE 10W-30
JASO T 903 standard	MA
suggested oil*	Pro Honda GN4 4-stroke Oil (USA & Canada), or Honda 4-stroke oil, or an equivalent motorcycle oil

\* Suggested 4-stroke engine oils are equal performance to SJ oils that are not labeled as energy conserving or resource conserving on the circular API service label.

- Your CRF does not need oil additives. Use the recommended oil.
- Do not use API SH or higher 4-stroke engine oils displaying a circular API “energy conserving” or “resource conserving” service label on the container. They may affect lubrication.

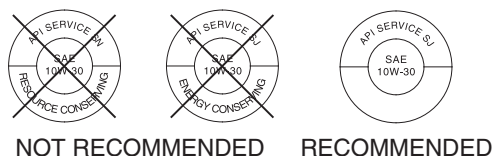

Other viscosities shown in the following chart may be used when the average temperature in your riding area is within the indicated range.

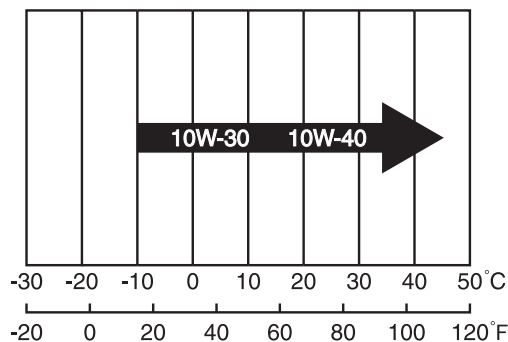

## JASO T 903 standard

The JASO T 903 standard is an index for engine oils for 4-stroke motorcycle engines. There are two classes: MA and MB. Oil conforming to the standard is labeled on the oil container. For example, the following label shows the MA classification.

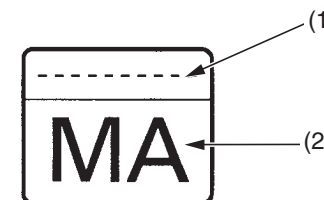

- (1) oil code
- (2) oil classification

## Checking & Adding Oil

1. Run the engine at idle for 3 minutes, then shut it off.
2. Wait 3 minutes after shutting off the engine to allow the oil to properly distribute itself in the engine.
3. Support the CRF in an upright position on a level surface.
4. Remove the engine oil fill cap/dipstick (1) from the left crankcase cover, wipe it clean, and insert it without screwing it in. Remove the oil fill cap/dipstick.
5. Check that the oil level is between the upper (2) and lower (3) level marks on the engine oil fill cap/dipstick.
  - If the oil is at or near the upper level mark, you do not have to add oil.
  - If the oil is below or near the lower level mark, add the recommended oil until it reaches the upper level mark. (Do not overfill.)
 Reinstall the engine oil fill cap/dipstick. Repeat steps 1 – 5.

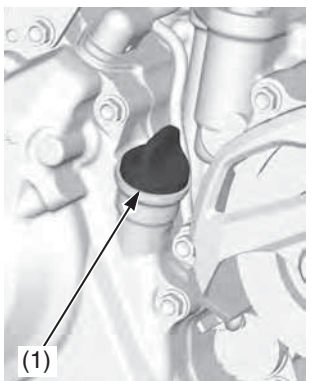

(1) engine oil fill cap/dipstick  
(2) upper level mark  
(3) lower level mark

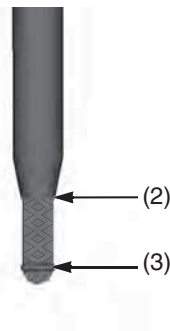

6. Check that the O-ring (4) is in good condition and replace it if necessary.
7. Reinstall the engine oil fill cap/dipstick (1).

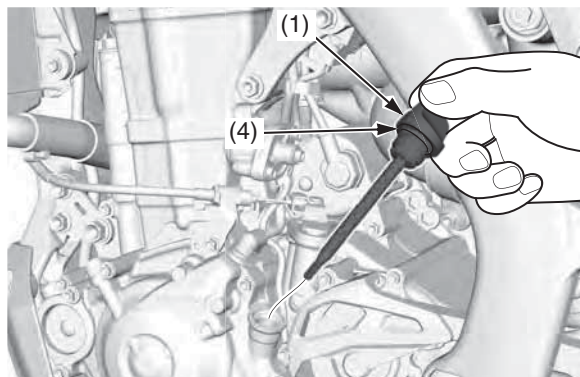

(1) engine oil fill cap/dipstick  
(4) O-ring

8. Check for oil leaks.

## Changing Engine Oil & Filter

1. Remove the engine guard A bolts/washers (1), B bolt/washer (2) and engine guard (3).

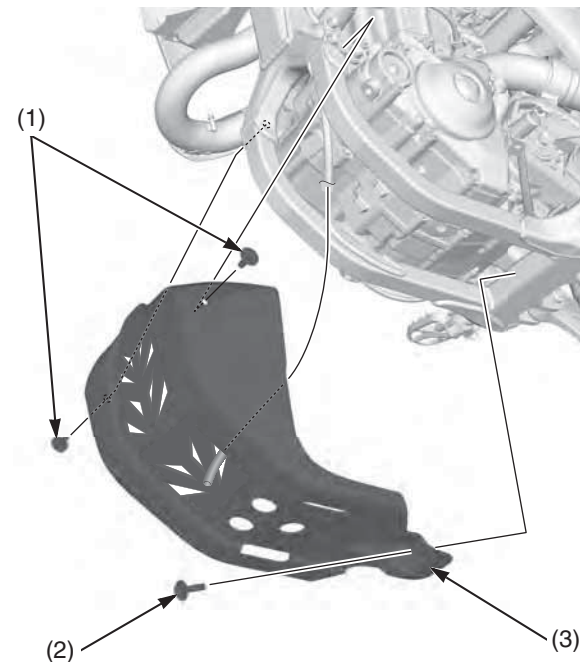

(1) engine guard A bolts/washers  
(2) engine guard B bolt/washer  
(3) engine guard

2. Run the engine at idle for 3 minutes, then shut it off.
3. Support the CRF in an upright position on a level surface.
4. Remove the engine oil fill cap/dipstick (4) from the left crankcase cover.

(cont'd)

# Engine Oil

- Place an oil drain pan under the engine to catch the oil. Then remove the engine oil drain bolt (5) and O-ring (6).
- With the engine stop button pushed, pull the clutch lever all the way in, and depress the start button to drain the engine oil completely.
- After the oil has drained, apply engine oil to the drain bolt threads, seating surface and a new O-ring, then install the O-ring on the drain bolt and tighten the drain bolt to the specified torque:  
**13 lbf-ft (18 N·m, 1.8 kgf·m)**

Pour the drained oil into a suitable container and dispose of it in an approved manner (page 164).

## NOTICE

*Improper disposal of drained fluids is harmful to the environment.*

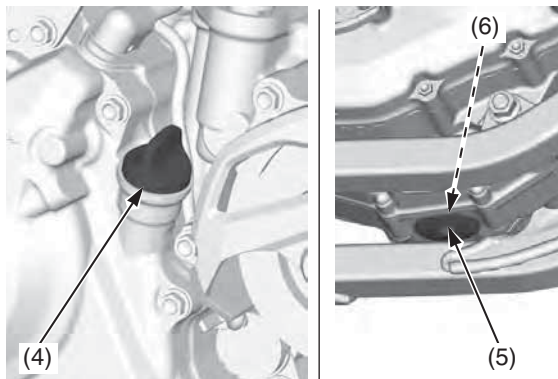

- (4) engine oil fill cap/dipstick  
(5) engine oil drain bolt  
(6) O-ring (new)

- (CRF450RX)  
It is recommended to replace the oil and filter every 4 races or about every 15.0 hours. However, if you replace only the oil before the recommended interval, see page 25.

(CRF450R/RWE)

It is recommended to replace the oil and filter every 6 races or about every 15.0 hours. However, if you replace only the oil before the recommended interval, see page 26.

- Remove the oil filter cover bolts (7) and oil filter cover (8).
- Remove the oil filter (9), O-ring (10) and spring (11).

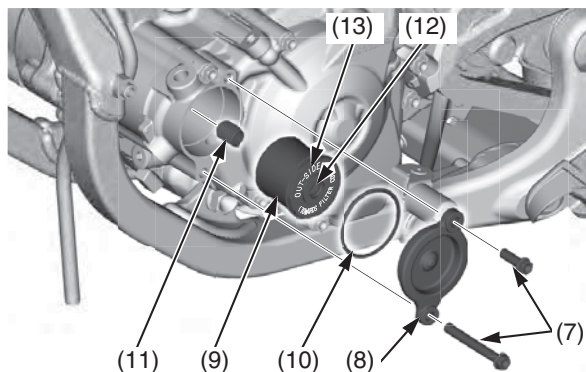

- (7) oil filter cover bolts  
(8) oil filter cover  
(9) oil filter  
(10) O-ring  
(11) spring  
(12) rubber seal  
(13) "OUT-SIDE" mark

## NOTICE

*Using the wrong oil filter may result in leaks or engine damage.*

- Apply grease to the filter side of the spring end, then install the spring into a new oil filter.
- Position the spring against the engine crankcase and install a new oil filter with the rubber seal (12) facing out, away from the engine. You should see the "OUT-SIDE" mark (13) on the filter body, near the rubber seal. Use a new Honda Genuine oil filter or a filter of equal quality specified for your model.

## NOTICE

*If the oil filter is not installed properly, it will cause serious engine damage.*

- Apply engine oil to a new O-ring and install it to the oil filter cover.
  - Install the oil filter cover being careful not to damage the O-ring, then tighten the oil filter cover bolts to the specified torque:  
**7 lbf-ft (10 N·m, 1.0 kgf·m)**
  - Install the engine guard, then tighten the engine guard A bolts/washers and B bolt/washer to the specified torque:  
**7 lbf-ft (10 N·m, 1.0 kgf·m)**
  - Fill the crankcase with the recommended oil.  
Capacity: **1.10 US qt (1.04 ℓ)**  
after draining and filter change  
**1.06 US qt (1.00 ℓ)**  
after draining
  - Install the engine oil fill cap/dipstick.
  - Check the engine oil level by following the steps in *Checking & Adding Oil* (page 63).
- Pour the drained oil into a suitable container and dispose of it in an approved manner (page 164).

## NOTICE

*Improper disposal of drained fluids is harmful to the environment.*

Refer to *Important Safety Precautions* on page 23.

Your CRF's liquid cooling system dissipates engine heat through the coolant jacket that surrounds the cylinder and cylinder head.

Maintaining the coolant will allow the cooling system to work properly and prevent freezing, overheating, and corrosion.

## Coolant Recommendation

Use Pro Honda HP Coolant or an equivalent high quality ethylene glycol antifreeze containing corrosion protection inhibitors specifically recommended for use in aluminum engines. Check the antifreeze container label.

Use only distilled water as a part of the coolant solution. Water that is high in mineral content or salt may be harmful to the aluminum engine.

## NOTICE

*Using coolant with silicate inhibitors may cause premature wear of the mechanical seal or blockage of the radiator passages. Using tap water may cause engine damage.*

The factory provides a 50/50 solution of antifreeze and water in this motorcycle. This coolant solution is recommended for most operating temperatures and provides good corrosion protection.

Decreasing the concentration of antifreeze to less than 40% will not provide proper corrosion protection.

Increasing the concentration of antifreeze is not recommended because it decreases cooling system performance. Higher concentrations of antifreeze (up to 60%) should only be used to provide additional protection against freezing. Check the cooling system frequently during freezing weather.

## Checking & Adding Coolant

Refer to *Important Safety Precautions* on page 23.

1. Position your CRF on an optional workstand or equivalent support so that it is securely held in place in an upright position.
2. With the engine cold, remove the radiator cap (1) and check coolant level. The coolant level is correct when it is at the bottom of the radiator filler neck (2).

## ⚠ WARNING

Removing the radiator cap while the engine is hot can cause the coolant to spray out, seriously scalding you.

Always let the engine and radiator cool down before removing the radiator cap.

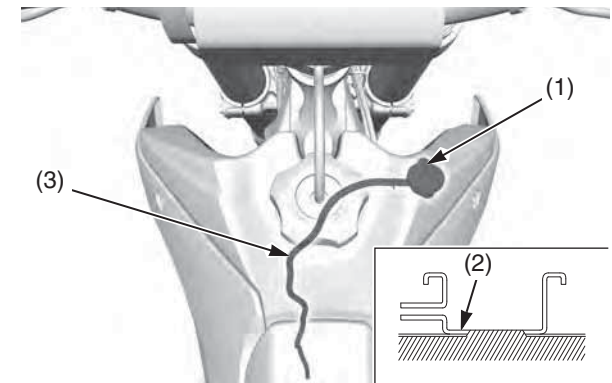

- (1) radiator cap  
(2) radiator filler neck  
(3) overflow hose

3. If the coolant level is low, add the coolant up to the filler neck.

Inspect the coolant level before each outing. A coolant loss of 0.7 – 2.0 US oz (20 – 60 cm<sup>3</sup>) through the overflow hose (3) is normal. If coolant loss is more than this, inspect the cooling system.

Capacity:

(CRF450RX)

1.22 US qt (1.15 ℓ) after disassembly

1.13 US qt (1.07 ℓ) after draining

(CRF450R/RWE)

1.19 US qt (1.13 ℓ) after disassembly

1.13 US qt (1.07 ℓ) after draining

4. Install the radiator cap securely.

## NOTICE

*If the radiator cap is not installed properly, it will cause excessive coolant loss and may result in overheating and engine damage.*



# Coolant

## Cooling System Inspection

1. Check the cooling system for leaks (see an official Honda Service Manual for troubleshooting of leaks).
2. Check the radiator hoses (1) for cracks, deterioration, and radiator hose clamps for looseness.
3. Check the radiator mount for looseness.
4. Make sure the overflow hose (2) is connected and not clogged.
5. Check the radiator fins (3) for clogging.

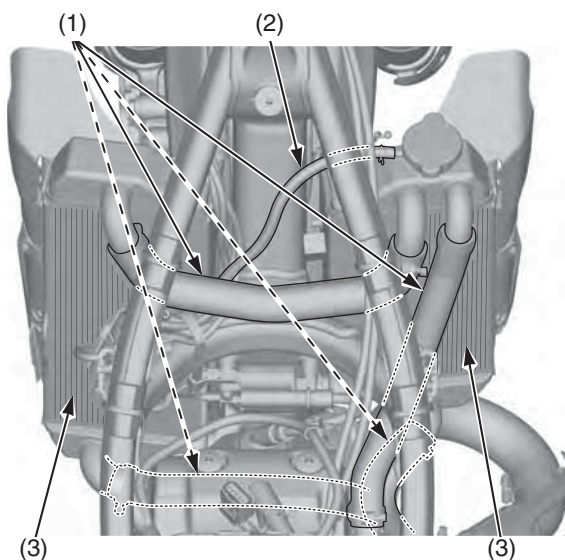

(1) radiator hoses  
(2) overflow hose

(3) radiator fins

6. Check the bleed hole (4) below the water pump cover (5) for leakage. Clean away any clogged dirt or sand, if necessary. Check the bleed hole of the water pump for signs of seal leakage. If water leaks through the bleed hole, replace the mechanical seal. If oil leaks through the bleed hole, replace the oil seal. Make sure that there is no continuous coolant leakage from the bleed hole while operating the engine. A small amount of coolant weeping from the bleed hole is normal. See an official Honda Service Manual or consult your dealer for replacing the mechanical seal or oil seal. Both seals should be replaced at the same time.

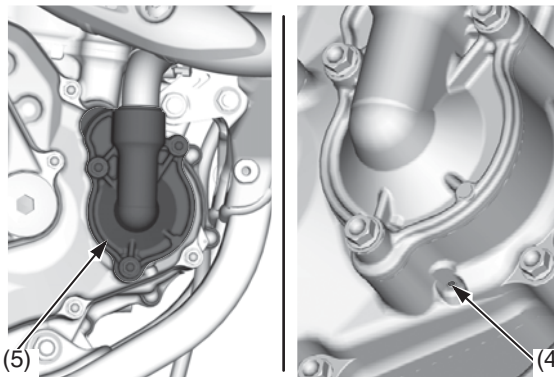

(4) bleed hole  
(5) water pump cover

7. Check the radiator air passages for clogging or damage. Straighten bent fins (6), and remove insects, mud or other obstructions with compressed air or low water pressure. Replace the radiator if the air flow is restricted over more than 20% of the radiating surface.

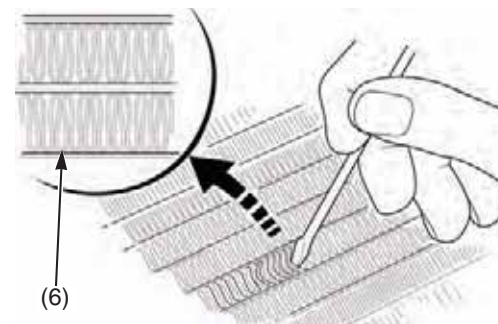

(6) fins

Radiator should be replaced by your dealer, unless you have the proper tools and service data and are mechanically qualified. Refer to an official Honda Service Manual (page 186).

## Coolant Replacement

Refer to *Important Safety Precautions* on page 23.

Coolant should be replaced by your dealer, unless you have the proper tools and service data and are mechanically qualified. Refer to an official Honda Service Manual (page 186).

### **⚠ WARNING**

Removing the radiator cap while the engine is hot can cause the coolant to spray out, seriously scalding you.

Always let the engine and radiator cool down before removing the radiator cap.

To properly dispose of drained coolant, refer to *You & the Environment* on page 164.

### **NOTICE**

*Improper disposal of drained fluids is harmful to the environment.*

Refer to *Important Safety Precautions* on page 23.

The air cleaner uses polyurethane inner and outer pieces which can't be separated. A dirty air cleaner will reduce engine power.

Proper air cleaner maintenance is very important for off-road vehicles. A dirty, water-soaked, worn-out, or defective air cleaner will allow dirt, dust, mud, and other impurities to pass into the engine.

Service the air cleaner more frequently if you ride in unusually wet or dusty areas. Your dealer can help you determine the correct service interval for your riding conditions.

Your CRF's air cleaner has very specific performance requirements. Use a new Honda Genuine air cleaner specified for your model or an air cleaner of equal quality.

## NOTICE

*Using the wrong air cleaner may result in premature engine wear.*

Proper air cleaner maintenance can prevent premature engine wear or damage, expensive repairs, low engine power, poor gas mileage, and spark plug fouling.

## NOTICE

*Improper or lack of proper air cleaner maintenance can cause poor performance and premature engine wear.*

## Cleaning

1. Remove the seat (page 34).
2. Remove the air cleaner retaining bolt (1) and air cleaner assembly (2).

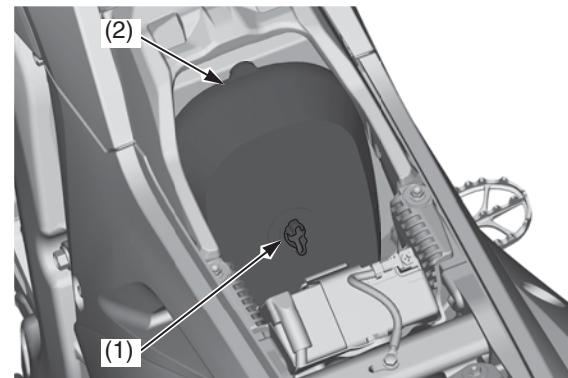

- (1) air cleaner retaining bolt  
(2) air cleaner assembly

3. Remove the air cleaner element (3) from the air cleaner holder (4) by releasing the hole (5) of the air cleaner element from the holder tab (6).

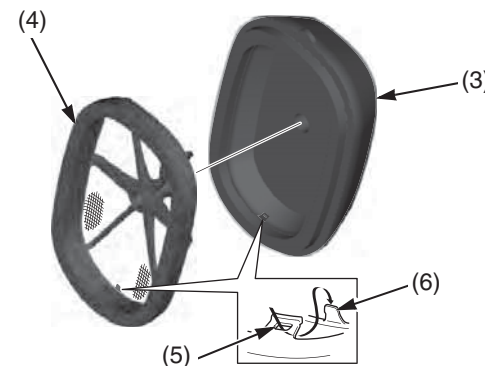

- (3) air cleaner element      (5) hole  
(4) air cleaner holder      (6) holder tab

(cont'd)



# Air Cleaner

4. Wash the air cleaner in clean non-flammable cleaning solvent such as Pro Honda foam air filter cleaner. Then wash in hot, soapy water, rinse well, and allow to dry thoroughly. The air cleaner element is made in two pieces: inner and outer, which cannot be separated.
5. Clean the inside of the air cleaner housing (7).
6. Allow the air cleaner to dry thoroughly. After drying, apply 1.4 US oz (40 cm<sup>3</sup>) of clean Pro Honda Foam Air Filter Oil or an equivalent air cleaner oil from the inside of the element. Place the element into a plastic bag (8) and spread the oil evenly by hand.

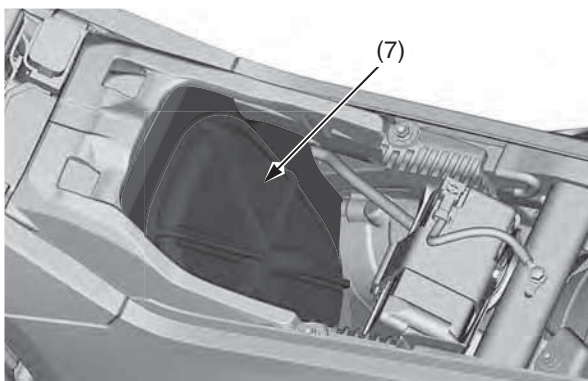

(7) air cleaner housing

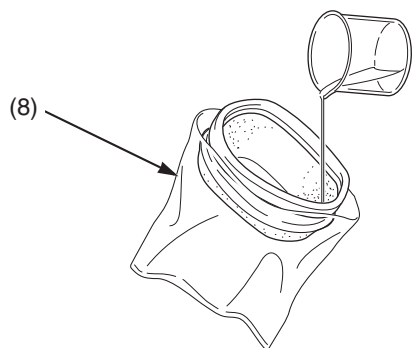

(8) plastic bag

7. Assemble the air cleaner element and holder. Install the holder tab in the hole of the air cleaner element.
8. Apply 0.05 – 0.19 oz (1.5 – 5.5 g) of Pro Honda Foam Air Filter Sealer or equivalent to the air cleaner element contact area (9) of the air cleaner housing.
9. Install the air cleaner assembly (2) into the air cleaner housing stay (10) with the “UP” mark tab (11) facing up.
10. Carefully position the sealing flange of the element to prevent dirt intrusion.

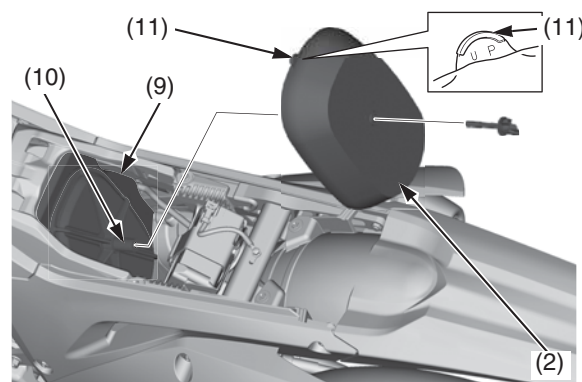

(2) air cleaner assembly  
(9) contact area  
(10) air cleaner housing stay  
(11) “UP” mark tab

11. Install and tighten the air cleaner retaining bolt (1) to the specified torque:  
1.8 lbf·ft (2.4 N·m, 0.2 kgf·m)

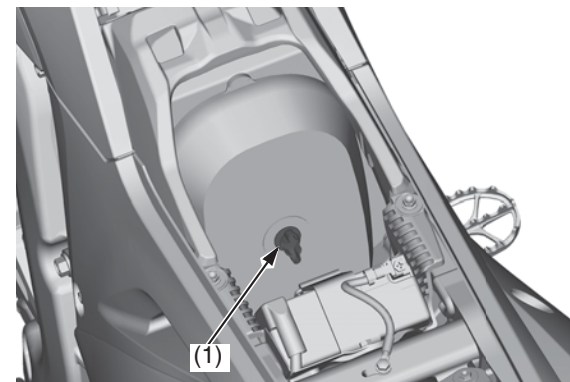

(1) air cleaner retaining bolt

## NOTICE

*Improper installation of the air cleaner assembly may allow dirt and dust to enter the engine and cause rapid wear of the piston rings and cylinder.*

12. Install the seat (page 34).

Refer to *Important Safety Precautions* on page 23.

Service more frequently if your CRF is ridden in the rain or often at full throttle.

Service the breather if you can see deposits in the transparent section of the crankcase breather tube. If the breather tube overflows, the air filter may become contaminated with engine oil causing poor engine performance.

## Draining

1. Remove the crankcase breather tube plug (1) from the crankcase breather tube (2) by sliding the clip (3) and drain deposits into a suitable container.
2. Reinstall the crankcase breather tube plug.

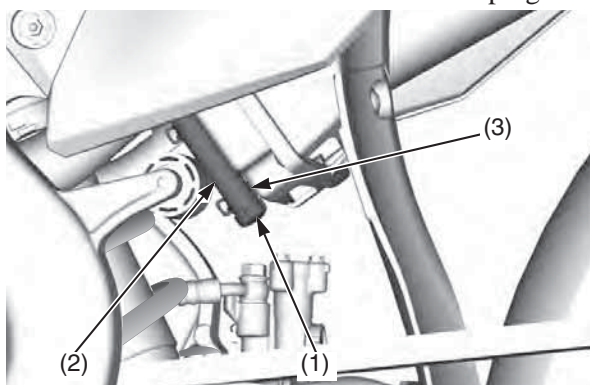

- (1) crankcase breather tube plug  
(2) crankcase breather tube  
(3) clip

# Throttle

Refer to *Important Safety Precautions* on page 23.

## Throttle Freeplay

### Inspection

Check freeplay (1).

Freeplay: 1/16 – 1/4 in (2 – 6 mm)

If necessary, adjust to the specified range.

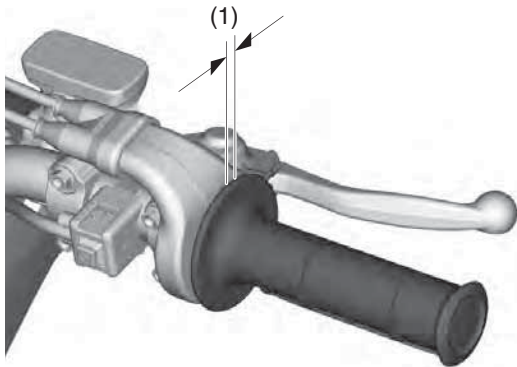

(1) freeplay

### Upper Adjustment

Minor adjustments are generally made with the upper adjuster.

1. Loosen the lock nut (1).
2. Turn the adjuster (2).  
Turning the adjuster in direction (–) will decrease freeplay and turning it in direction (+) will increase freeplay.

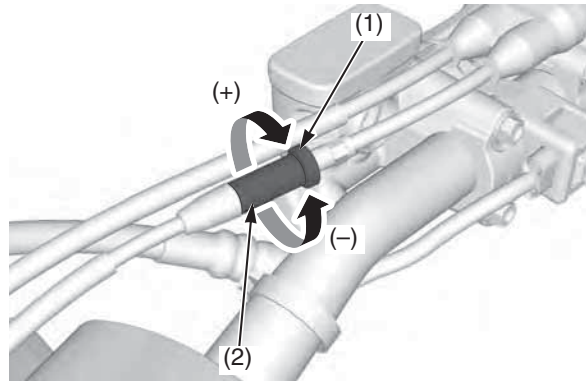

(1) lock nut  
(2) adjuster  
(+) increase freeplay  
(–) decrease freeplay

3. Tighten the lock nut securely.
4. After adjustment, check for smooth rotation of the throttle grip from fully closed to fully open in all steering positions.  
If the adjuster is threaded out near its limit or the correct freeplay cannot be reached, turn the adjuster all the way in and back out one turn. Tighten the lock nut securely.  
Make the adjustment with the lower adjuster.

### Lower Adjustment

The lower adjuster is used for major freeplay adjustment, such as after replacing the throttle cables or removing the throttle body. It is also used if you cannot get the proper adjustment with the upper adjuster.

1. Loosen the lock nut (1).
2. Turn the adjuster (2) in direction (–) to decrease freeplay, and in direction (+) to increase freeplay.

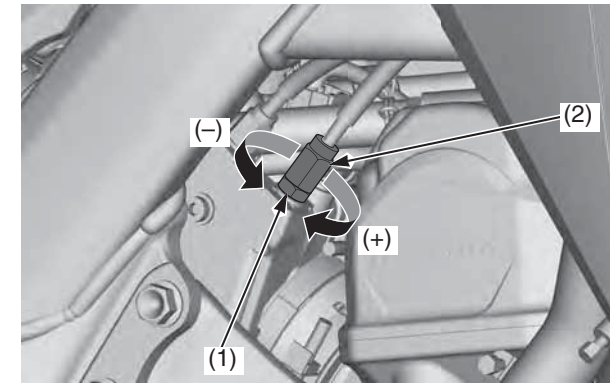

(1) lock nut  
(2) adjuster  
(+) increase freeplay  
(–) decrease freeplay

3. Tighten the lock nut to the specified torque:  
**3.0 lbf·ft (4.0 N·m, 0.4 kgf·m)**
4. Operate the throttle grip to ensure that it functions smoothly and returns completely.

If you can't get the freeplay within the specified range, contact your dealer.

## Throttle Inspection

1. Check that the throttle assembly is positioned properly (the end of the throttle housing (1) is aligned with the paint mark (2) on the handlebar) and the securing bolts are tight.

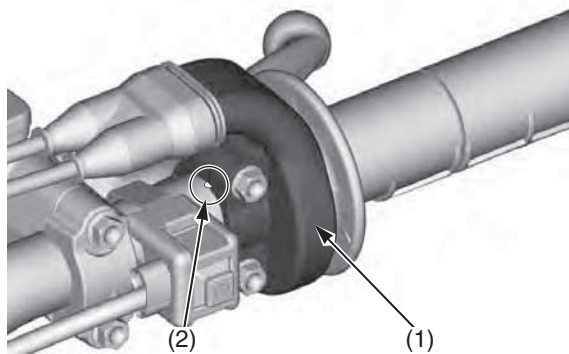

(1) throttle housing  
(2) paint mark

2. Check for smooth rotation of the throttle (3) from fully open to fully closed in all steering positions. If there is a problem, see your dealer.

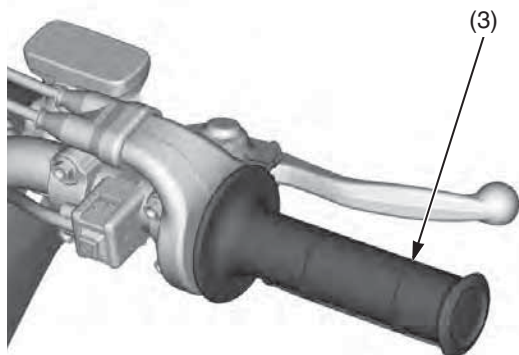

(3) throttle

3. Inspect the condition of the throttle cables from the throttle grip down to the throttle body. If the cable is kinked or chafed, have it replaced.
4. Check the cables for tension or stress in all steering positions.
5. Lubricate the cables with a commercially available cable lubricant.

## Throttle Cable Lubrication

Check for smooth rotation of the throttle. If necessary, apply multi-purpose grease to sliding surface of the throttle cable ends.

1. Slide the dust cover (1).
2. Remove the throttle housing bolts (2).
3. Remove the throttle housing (3) from the throttle pipe (4).
4. Thoroughly lubricate the throttle cable ends (5) with multi-purpose grease.

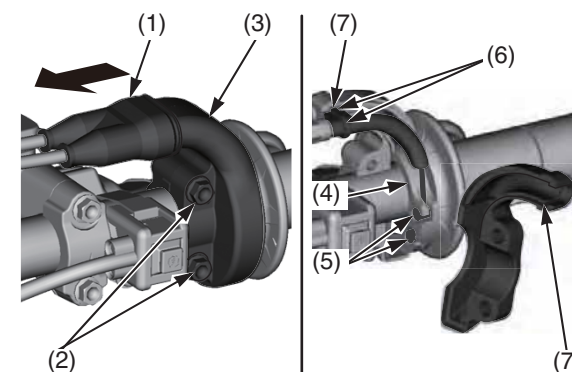

(1) dust cover  
(2) housing bolts  
(3) throttle housing  
(4) throttle pipe

(5) throttle cable ends  
(6) lugs  
(7) grooves

5. Install the throttle housing, then tighten the throttle housing bolts to the specified torque:  
7 lbf-ft (10 N·m, 1.0 kgf·m)

### NOTICE

*Align the lugs (6) of the wire guide with the grooves (7) of the throttle housing.*

6. Install the dust cover in the reverse order.

If the throttle operation is not smooth, replace the throttle cable.

Be sure the throttle returns freely from fully open to fully closed automatically, in all steering positions.

# Engine Idle Speed

Refer to *Important Safety Precautions* on page 23.

Remember, idle speed adjustment is not a “cure-all” for other problems in your engine’s PGM-FI system. Adjusting the idle speed will not compensate for a fault elsewhere.

The engine must be at normal operating temperature for accurate idle speed adjustment. When pushed in, the fast idle knob acts as the idle adjustment screw.

Turning it counterclockwise results in a faster/higher idle speed.

Turning it clockwise results in a slower/lower idle speed.

## Idle Speed Adjustment

1. If the engine is cold, start it and warm it up 3 minutes. Then shut it off.
2. Connect a tachometer to the engine.
3. Shift the transmission into neutral. Start the engine.
4. Adjust idle speed with the fast idle knob (1).  
Idle speed:  $2,000 \pm 100$  rpm

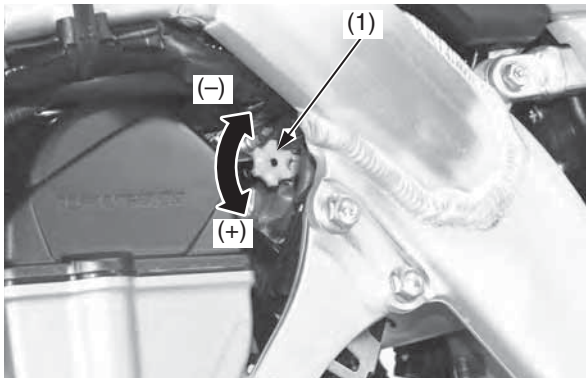

- (1) fast idle knob
- (+) increase
- (-) decrease



Refer to *Important Safety Precautions* on page 23.

## Clutch Lever Freeplay

### Inspection

Check freeplay (1).

Freeplay: 3/8 – 13/16 in (10 – 20 mm)

If necessary, adjust to the specified range.

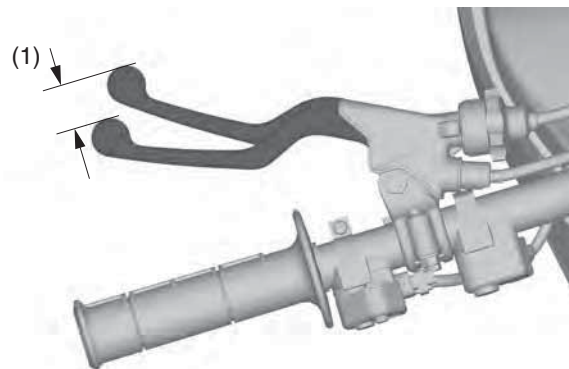

(1) freeplay

Improper freeplay adjustment can cause premature clutch wear.

Make sure to adjust the clutch lever freeplay after the clutch cable is disconnected.

### Cable End Adjustment

Minor adjustments are generally made with the clutch cable end adjuster.

Turning the clutch cable end adjuster (1) in direction (+) will increase freeplay and turning it in direction (-) will decrease freeplay.

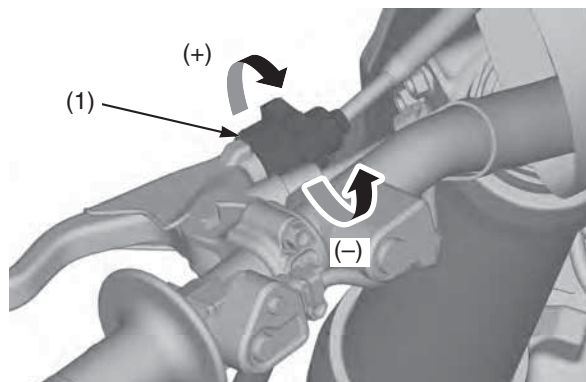

(1) clutch cable end adjuster  
(+) increase freeplay  
(-) decrease freeplay

If the adjuster is threaded out near its limit or the correct freeplay cannot be reached, turn the adjuster all the way in and back out five turns and make the adjustment with the integral cable adjuster.

### Integral Cable Adjustment

The integral cable adjuster is used if the cable end adjuster is threaded out near its limit — or the correct freeplay cannot be obtained.

1. Turn the cable end adjuster in direction (+) until it seats lightly and then turn it out five turns.
2. Loosen the lock nut (1).
3. Slide the rubber boot (2) off and turn the integral cable adjuster (3) to obtain the specified freeplay.
4. Once the specified freeplay has been obtained, slide the rubber boot on and tighten the lock nut.

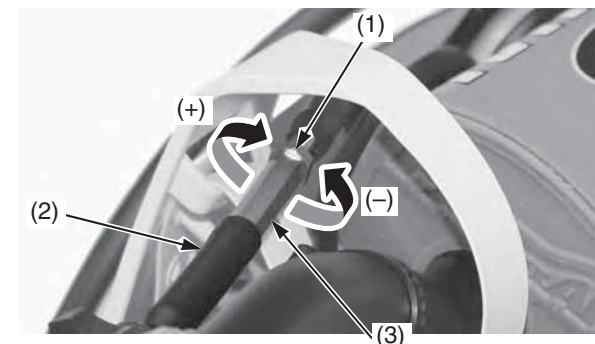

(1) lock nut  
(2) rubber boot  
(3) integral cable adjuster  
(+) increase freeplay  
(-) decrease freeplay

5. Start the engine, pull the clutch lever in, and shift into gear. Make sure the engine does not stall and the motorcycle does not creep. Gradually release the clutch lever and open the throttle. Your CRF should move smoothly and accelerate gradually.

If you can't get proper adjustment, or the clutch does not work properly, the cable may be kinked or worn, or the clutch discs may be worn. Inspect the clutch discs and plates (page 76).



# Clutch System

## Other Inspections

- Check that the clutch lever assembly is positioned properly (the end of the holder (1) is aligned with the paint mark (2) on the handlebar) and the securing bolts are tight.

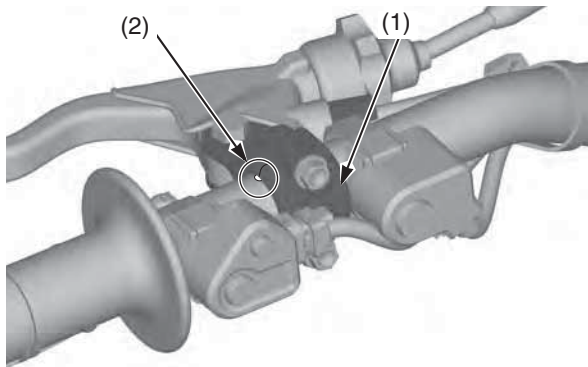

(1) holder  
(2) paint mark

- Check the clutch cable for kinks or signs of wear. If necessary, have it replaced.

## Clutch Operation

1. Check for smooth clutch lever operation. If necessary, lubricate the clutch lever pivot bolt sliding surface with grease and/or clutch cable with commercially available cable lubricant.
2. Check the clutch cable for deterioration, kinks, or damage.

## Clutch Cable Lubrication

Check for smooth clutch lever operation. If necessary, apply multi-purpose grease to sliding surface of the clutch cable ends.

1. Release the dust cover (1).
2. Turn the adjuster (2) and remove the clutch cable (3).
3. Disconnect the clutch cable end from the clutch lever (4).
4. Thoroughly lubricate the clutch cable end (5) with multi-purpose grease.

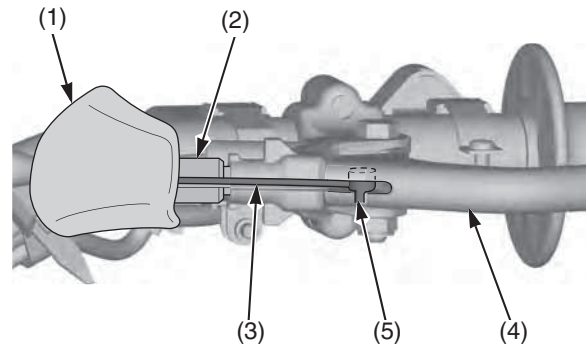

(1) dust cover  
(2) adjuster  
(3) clutch cable  
(4) clutch lever  
(5) clutch cable end

5. Connect the clutch cable end to the lever.
6. Install the clutch cable and turn the adjuster.

7. Remove the clutch cable end adjuster (6).
8. Apply multi-purpose grease to the clutch cable end adjuster inside surface.

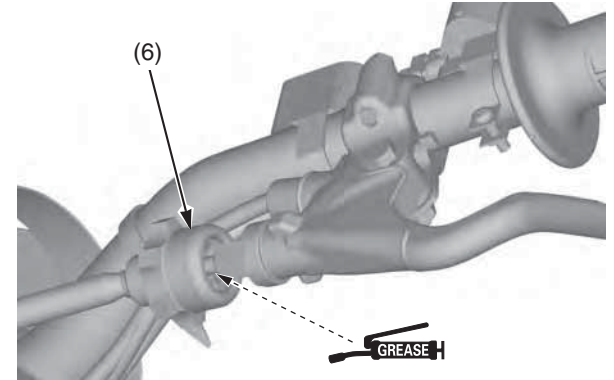

(6) clutch cable end adjuster

9. Recheck clutch lever freeplay and adjust as necessary (page 73).

If the clutch lever operation is not smooth, replace the clutch cable.

## Clutch Disc/Plate Removal

1. Drain the engine oil (page 63).
2. Remove the six clutch cover bolts (1) and clutch cover (2).

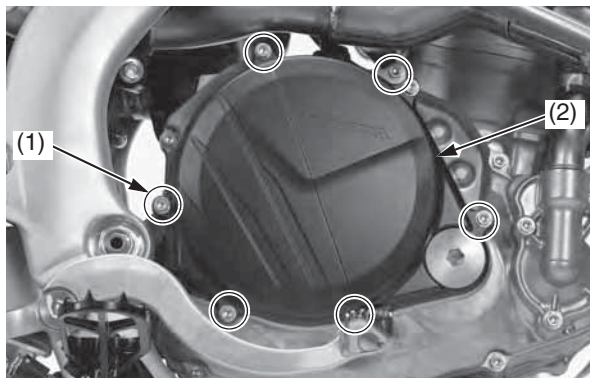

(1) clutch cover bolts      (2) clutch cover

3. Remove the six clutch spring bolts and springs (3).

Loosen the bolts in a crisscross pattern in two or three progressive steps.

4. Remove the clutch pressure plate (4).

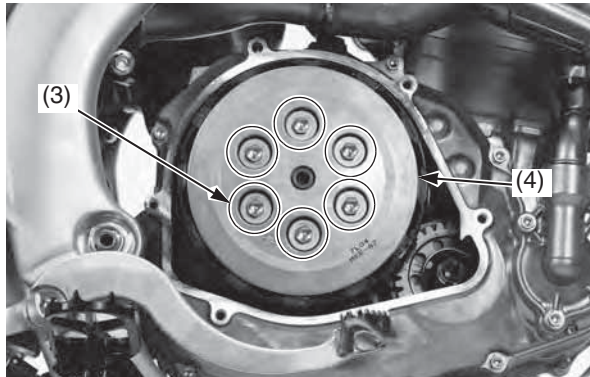

(3) clutch spring bolts and springs  
(4) clutch pressure plate

5. Remove the clutch lifter (5).

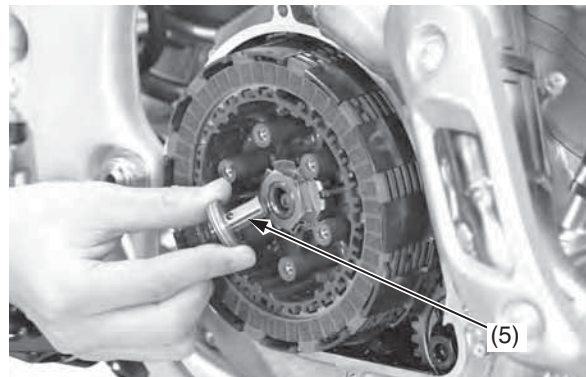

(5) clutch lifter

6. Check the operation of the thrust bearing (6) built in clutch lifter with your finger. The bearing should turn smoothly and quietly.

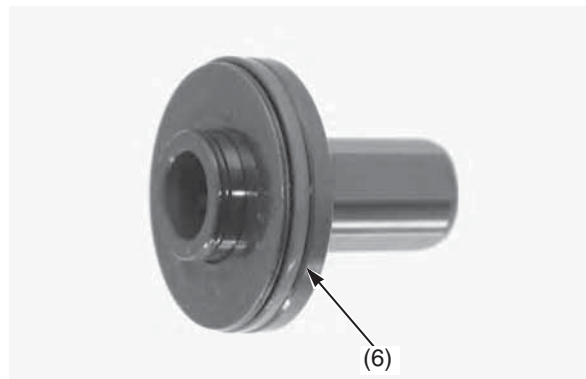

(6) thrust bearing

If the operation is not smooth, refer to an official Honda Service Manual (page 186) for bearing disassembly or see your dealer.

7. Remove the seven clutch discs, six clutch plates, judder spring and spring seat (7).

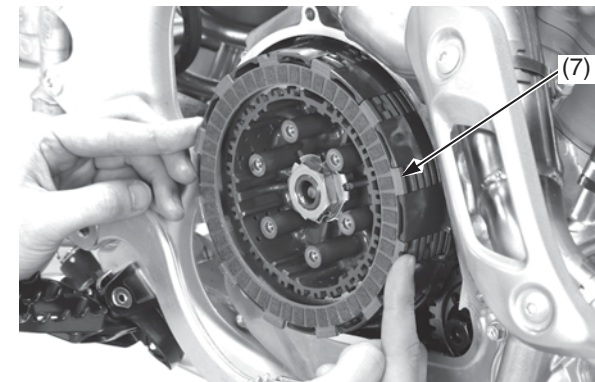

(7) clutch discs, clutch plates, judder spring and spring seat

# Clutch System

## Clutch Disc/Plate/Spring Inspection

- Replace the clutch discs (1) if they show signs of scoring or discoloration.  
Measure the thickness of each clutch disc.  
Service Limit: 0.112 in (2.85 mm)  
Replace the clutch discs and clutch plates as a set.

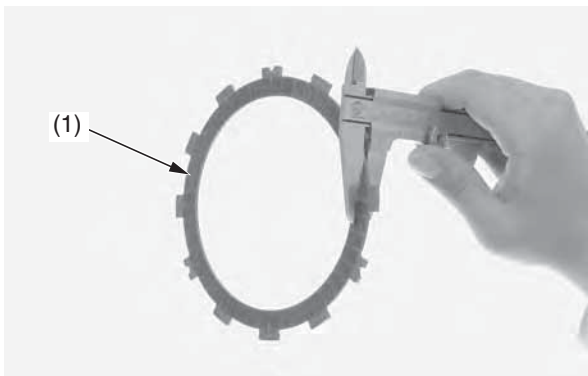

(1) clutch discs

- Check the clutch plates (2) for excessive warpage or discoloration.  
Check the plate warpage on a surface plate using a feeler gauge.  
Service Limit: 0.006 in (0.15 mm)  
Replace the clutch discs and plates as a set.

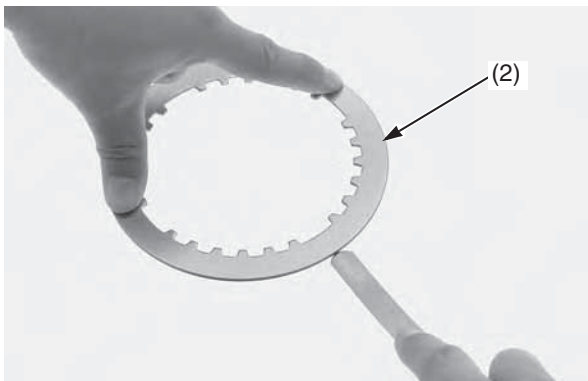

(2) clutch plates

- Check the clutch springs (3) for wear or damage.  
Measure the free length of each clutch spring.  
Service Limit: 1.917 in (48.70 mm)  
Replace the clutch spring as a set.

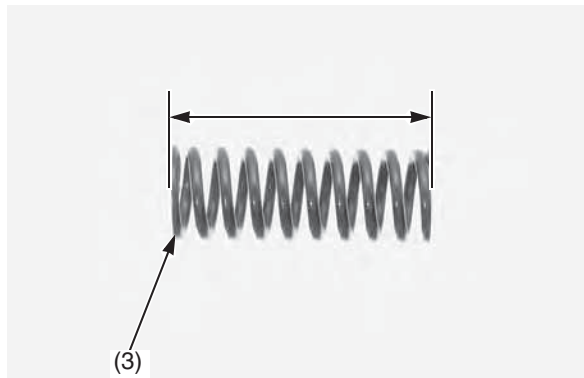

(3) clutch springs

- If you feel the clutch slipping after replacing the clutch disc and plate, replace the clutch springs.

## Clutch Disc/Plate Installation

1. Install the spring seat (1) and judder spring (2) onto the clutch center as shown.  
Coat the clutch discs with engine oil.
2. Install the clutch disc A (larger I.D. disc) (3) onto the clutch outer.  
Stack the six clutch plates (4), five clutch discs B (5) alternately while aligning the lugs (6) of the clutch center with the groove (7) of the clutch plates as shown.  
Install the clutch disc C (8).

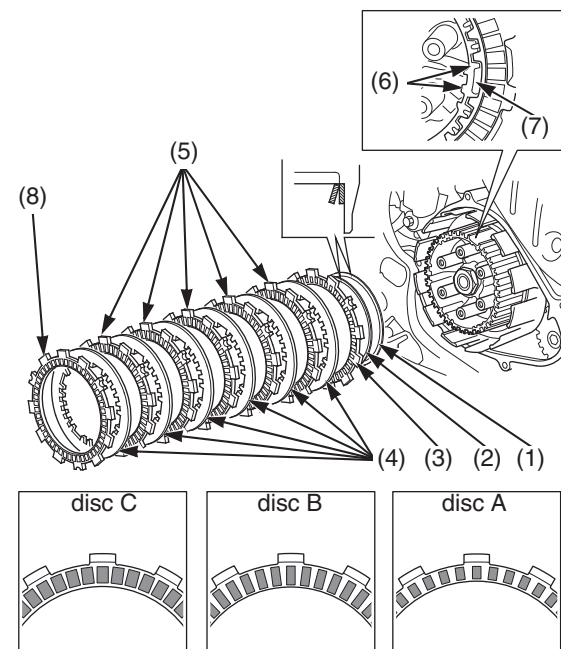

- (1) spring seat  
(2) judder spring  
(3) clutch disc A  
(4) clutch plates

- (5) clutch discs B  
(6) lugs  
(7) groove  
(8) clutch disc C



3. Install the clutch lifter (9) onto the clutch lifter rod (10).

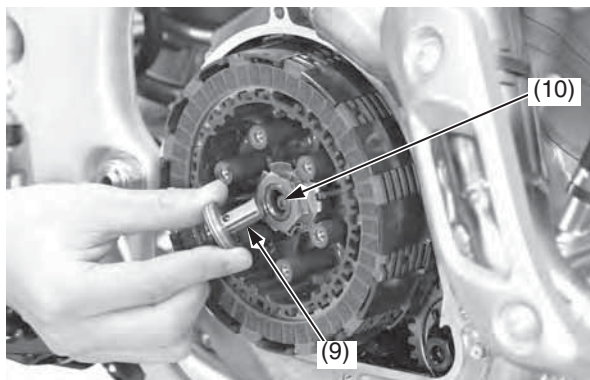

(9) clutch lifter      (10) clutch lifter rod

4. Install the clutch pressure plate (11).
5. Install the six clutch springs and bolts (12).
6. Tighten the bolts in a crisscross pattern in two or three steps to the specified torque:  
9 lbf-ft (12 N·m, 1.2 kgf·m)

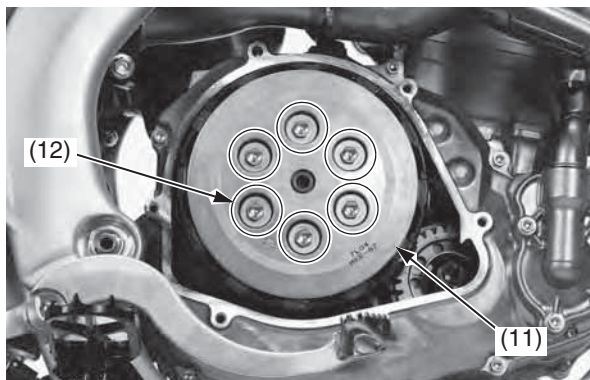

(11) clutch pressure plate  
(12) clutch springs and bolts

7. Apply engine oil to a new O-ring (13) and install it in the groove of the clutch cover (14).
8. Install the cover by tightening the six cover bolts in a crisscross pattern in two or three steps to the specified torque:  
7 lbf-ft (10 N·m, 1.0 kgf·m)

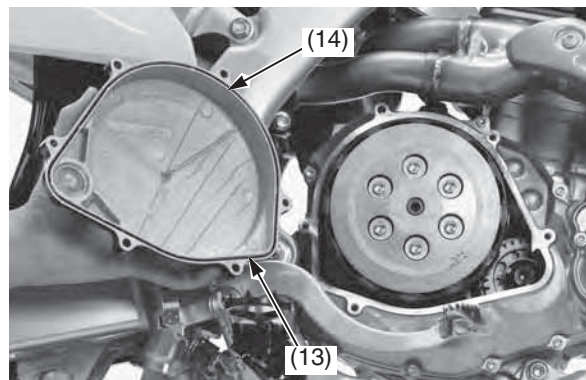

(13) O-ring (new)  
(14) clutch cover

9. Fill the crankcase with the recommended oil (page 63).

# Spark Plug

Refer to *Important Safety Precautions* on page 23.

## Spark Plug Recommendation

The recommended standard spark plug is satisfactory for most racing conditions.

Standard	SILMAR9A – 9S (NGK)
Optional	SILMAR10A – 9S (NGK)

Use only the recommended type of spark plugs in the recommended heat range.

### NOTICE

*Using a spark plug with an improper heat range or incorrect reach can cause engine damage. Using a non-resistor spark plug may cause ignition problems.*

This motorcycle uses a spark plug that has an iridium tip in the center electrode and a platinum tip in the side electrode.

Be sure to observe the following when servicing the spark plug.

- Do not clean the spark plug. If an electrode is contaminated with accumulated objects or dirt, replace the spark plug with a new one.
- To check the spark plug gap, use only a “wire-type feeler gauge.” To prevent damaging the iridium tip of the center electrode and platinum tip of the side electrode, never use a “leaf-type feeler gauge.”
- Do not adjust the spark plug gap. If the gap is out of specification, replace the spark plug with a new one.

## Spark Plug Inspection & Replacement

1. Remove the seat and hang the fuel tank to the left of the frame (pages 34, 35, 37).
2. Disconnect the spark plug cap (1).
3. Clean any dirt from around the spark plug base.
4. Remove the spark plug (2).

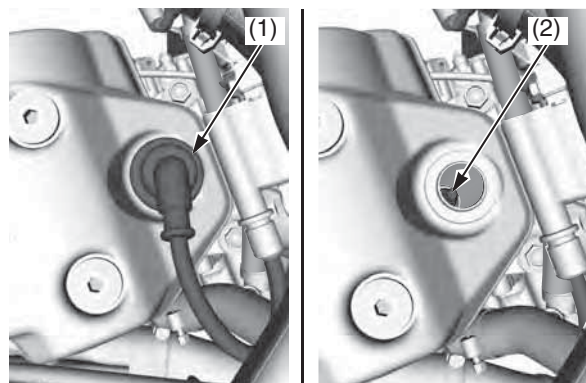

(1) spark plug cap

(2) spark plug

5. Check the electrodes for wear or deposits, the sealing gasket (3) for damage, and the insulator for cracks. Replace if you detect them.
6. Check the spark plug gap (4), using a wire-type feeler gauge. If the gap is out of specifications, replace the plug with a new one.  
The recommended spark plug gap is:  
0.031 – 0.035 in (0.8 – 0.9 mm)

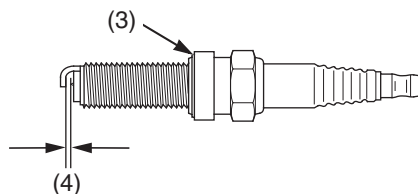

(3) sealing gasket  
(4) spark plug gap

7. To obtain accurate spark plug readings, accelerate up to speed on a straightaway. Press and hold the engine stop button and disengage the clutch by pulling the lever in. Coast to a stop, then remove and inspect the spark plug. The porcelain insulator around the center electrode should appear tan or medium gray.

If you're using a new plug, ride for at least 10 minutes before taking a plug reading; a brand-new plug will not color initially.

If the electrodes appear burnt, or the insulator is white or light gray (lean) or the electrodes and insulator are black or fouled (rich), there is a problem elsewhere (page 155). Check the PGM-FI system and ignition timing.

8. With the sealing gasket attached, thread the spark plug in by hand to prevent cross-threading.
9. Tighten the spark plug.
  - If the old plug is good:  
1/12 turn after it seats.
  - If installing a new plug, tighten it twice to prevent loosening:
    - a) First, tighten the plug:  
1/4 turn after it seats.
    - b) Then loosen the plug.
    - c) Next, tighten the plug again:  
1/12 turn after it seats.

### NOTICE

*An improperly tightened spark plug can damage the engine. If a plug is too loose, the piston may be damaged. If a plug is too tight, the threads may be damaged.*

10. Connect the spark plug cap. Take care to avoid pinching any cables or wires.
11. Install the fuel tank and seat (pages 34, 36, 38).

Refer to *Important Safety Precautions* on page 23.

Excessive valve clearance will cause noise and eventual engine damage. Little or no clearance will prevent the valve from closing and cause valve damage and power loss. Check valve clearance when the engine is cold at the intervals specified in the Maintenance Schedule (pages 25, 26).

The checking or adjusting of the valve clearance should be performed while the engine is cold. The valve clearance will change as engine temperature rises.

## Cylinder Head Cover Removal

Before inspection, clean the engine thoroughly to keep dirt from entering the engine.

1. Remove the seat and hang the fuel tank to the left of the frame (pages 34, 35, 37).
2. Disconnect the breather tube (1) and spark plug cap (2).

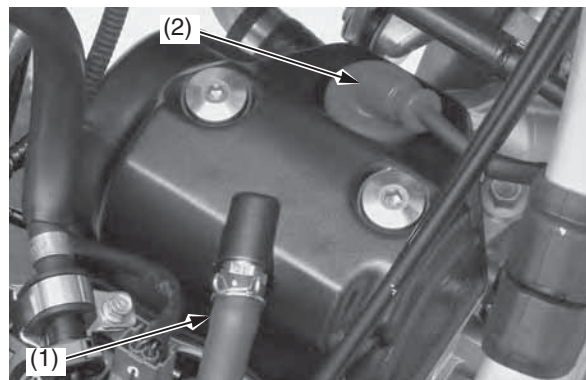

(1) breather tube

(2) spark plug cap

3. Remove the cylinder head cover socket bolts (3), rubber seals (4), cylinder head cover (5) and spark plug hole packing (6).

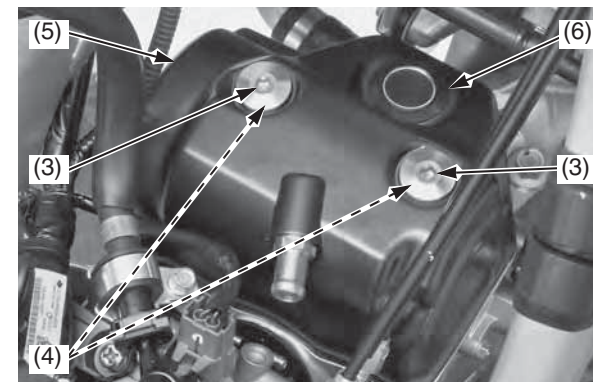

- (3) cylinder head cover socket bolts
- (4) cylinder head cover rubber seals
- (5) cylinder head cover
- (6) spark plug hole packing



# Valve Clearance

## Positioning At TDC On The Compression Stroke

1. Remove the crankshaft hole cap (1).

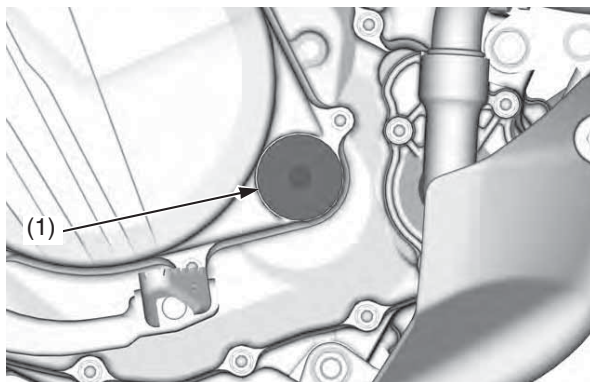

(1) crankshaft hole cap

2. Remove the spark plug (page 78).
3. Remove the cylinder head cover (page 79).

4. Rotate the crankshaft by turning the primary drive gear bolt (2) clockwise until "T" mark (3) on the primary drive gear aligns with the index mark (4) on the clutch cover. In this position, the piston may either be on the compression or exhaust stroke at TDC. If the primary drive gear passed the "T" mark, rotate the primary drive gear bolt clockwise again and align the "T" mark with the index mark. Make sure that the decompressor weight (5) is upper position.

crankshaft side:

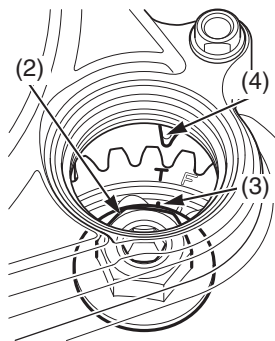

camshaft side:

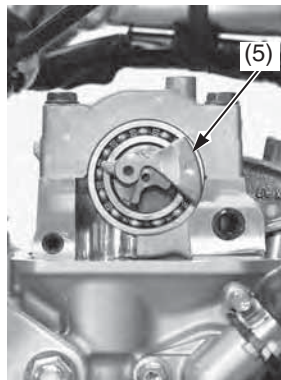

- (2) primary drive gear bolt
- (3) "T" mark
- (4) index mark
- (5) decompressor weight

5. Check the timing marks (6) on the cam sprocket aligns with the camshaft holder mating surface (7) of the cylinder head.

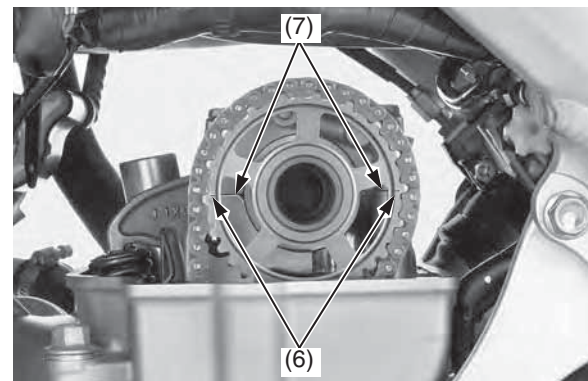

- (6) timing marks
- (7) camshaft holder mating surface

6. The inspection must be made when the piston is at the top of the compression stroke when both the intake and exhaust valves are closed. This condition can be determined by moving the rocker arms (8).

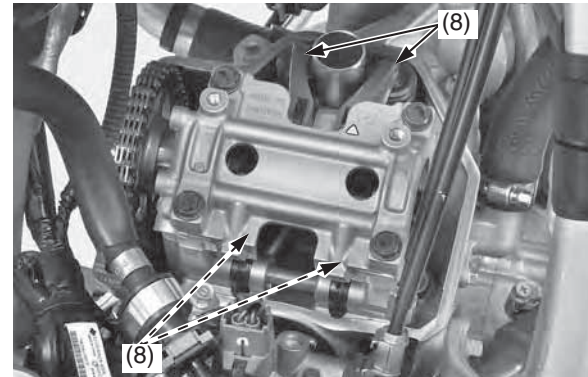

(8) rocker arms

## Valve Clearance Inspection

1. Set the piston at TDC on the compression stroke (page 80).
2. Measure the intake valve clearances by inserting a feeler gauge (1) between the intake rocker arms (2) and camshaft cam lobes (3).

### NOTICE

Be careful not to damage the intake rocker arms.

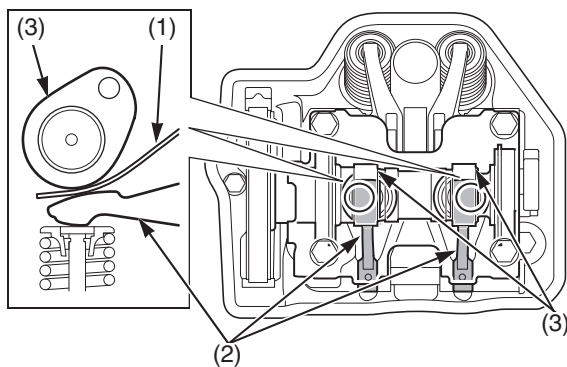
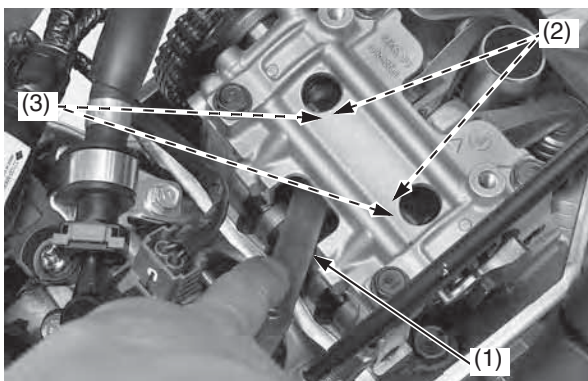

- (1) feeler gauge  
(2) intake rocker arms  
(3) camshaft cam lobes

Valve Clearance:

IN:  $0.005 \pm 0.001$  in ( $0.13 \pm 0.03$  mm)

3. Measure the exhaust valve clearances by inserting a feeler gauge (1) between the exhaust rocker arms (4) and shims (5).

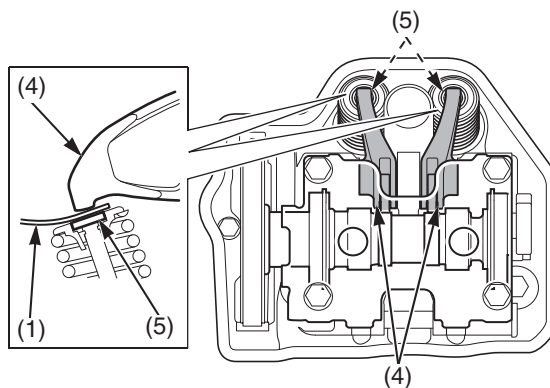
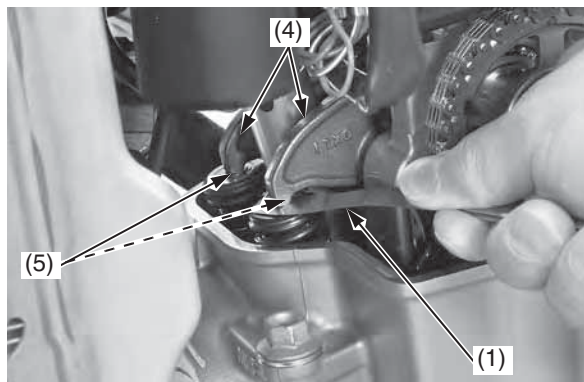

- (1) feeler gauge  
(4) exhaust rocker arms  
(5) valve shims

Valve Clearance:

EX:  $0.011 \pm 0.001$  in ( $0.28 \pm 0.03$  mm)

If intake valve clearance and exhaust valve clearance need adjustment, see Camshaft Removal (this page) and select the correct shim for each valve.

## Camshaft Removal

1. Make sure the piston is at TDC on the compression stroke (page 80). Record the intake valve and exhaust valve clearances (this page).
2. Remove the cam chain tensioner lifter cover bolt (1) and sealing washer (2).

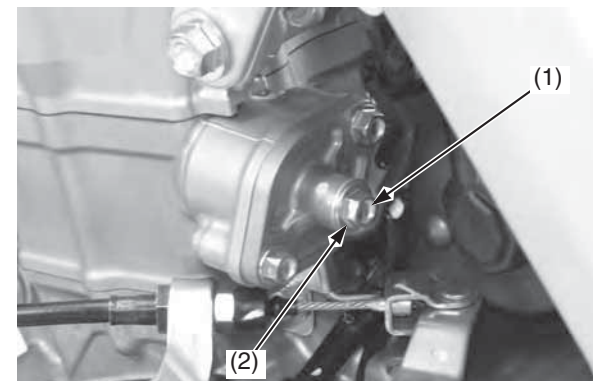

- (1) cam chain tensioner lifter cover bolt  
(2) sealing washer

(cont'd)

# Valve Clearance

3. Insert the tensioner stopper (3) into the cam chain tensioner lifter (4).  
Turn the tensioner stopper clockwise and lock the cam chain tensioner lifter by pushing the handle (5) to the cam chain tensioner lifter.
- Tensioner stopper 07AMG-001A100

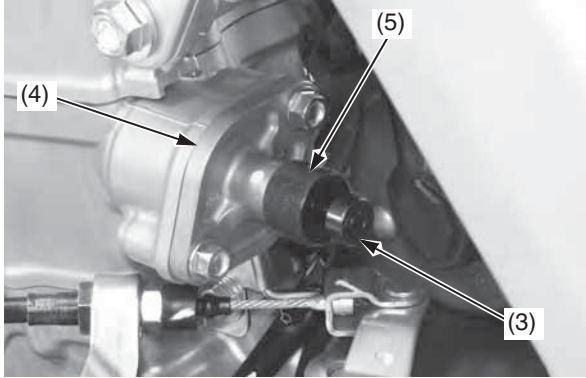

(3) tensioner stopper  
(4) cam chain tensioner lifter  
(5) handle

4. Check the piston is at TDC on the compression stroke (page 80).  
Loosen the camshaft holder bolts (6) in a crisscross pattern in two or three steps.  
Remove the camshaft holder bolts, camshaft holder (7) and set rings (8).

As you remove the camshaft holder, set rings may be sticking in the camshaft holder.

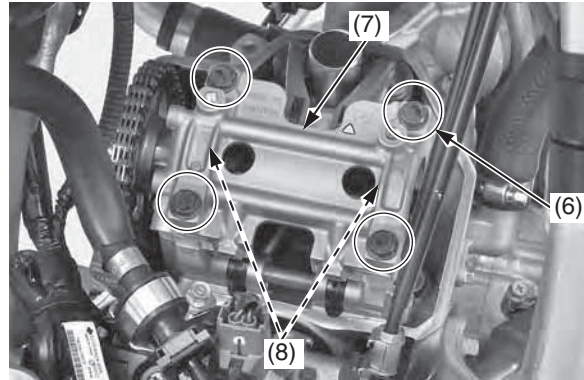

(6) camshaft holder bolts  
(7) camshaft holder  
(8) set rings

### NOTICE

*Do not let the set rings fall into the crankcase.*

If the set rings are remained on the camshaft holder, remove the set rings carefully.

5. Slide the left camshaft bearing (9) and remove the camshaft (10) by removing the cam chain (11).

Suspend the cam chain with a piece of wire to prevent the chain from falling into the crankcase.

### NOTICE

*Do not let the cam chain fall into the crankcase.*

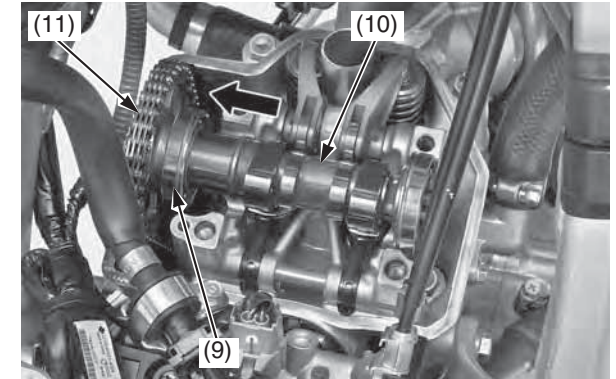

(9) left camshaft bearing  
(10) camshaft  
(11) cam chain



- Lift the rocker arms (12) up and remove the shims (13).

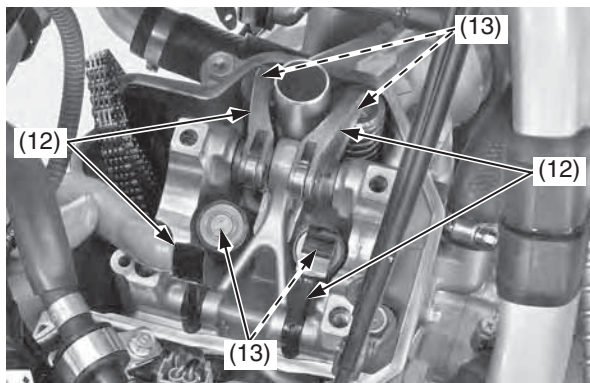

(12) rocker arms  
(13) shims

### NOTICE

*Be careful not to damage the intake rocker arms. Do not clean the intake rocker arms using a commercially available compound cleaner.*

### Shim Selection

- Measure the shim thickness with a micrometer and record it.  
Seventy-three different shims (1) are available in 0.025 mm thickness intervals, from 1.200 mm (the thinnest) to 3.000 mm (the thickest).

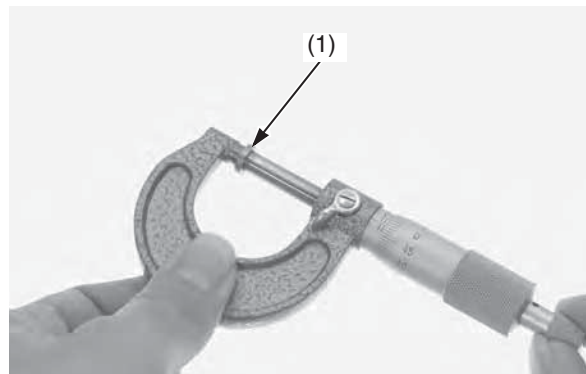

(1) shim

- Calculate the new shim thickness using the equation below.

$$A = (B - C) + D$$

A: New shim thickness  
B: Recorded valve clearance  
C: Specified valve clearance  
D: Old shim thickness

- Make sure of the correct shim thickness by measuring the shim with a micrometer.
- Reface the exhaust valve seat if carbon deposits result in a calculated dimension of over 3.000 mm.

### NOTICE

*Do not lap the intake valves. They are titanium and have a thin oxide coating. Lapping will damage this coating.*

If a calculated dimension is out of specifications, have your motorcycle inspected by your dealer.

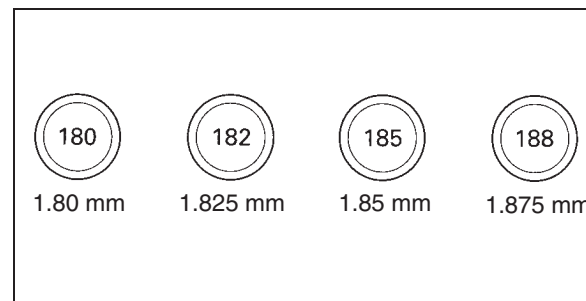

# Valve Clearance

## Camshaft Installation

1. Lift the rocker arms (1) up and install the newly selected shims (2) on the valve spring retainers (3).

### NOTICE

*Do not let the shims fall into the crankcase.*

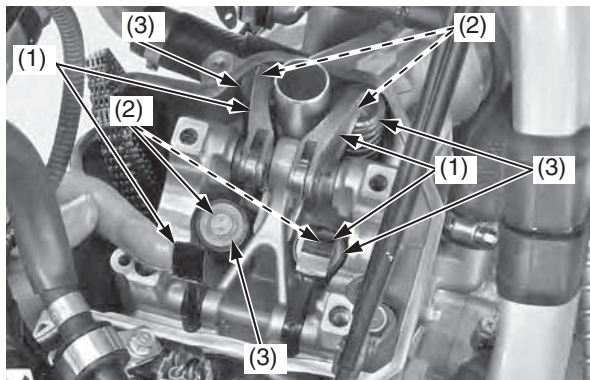

(1) rocker arms  
(2) shims  
(3) valve spring retainers

2. Check the operation of the plunger (4) by turning the decompressor weight (5) with your finger. The plunger should be retracted and protruded smoothly.

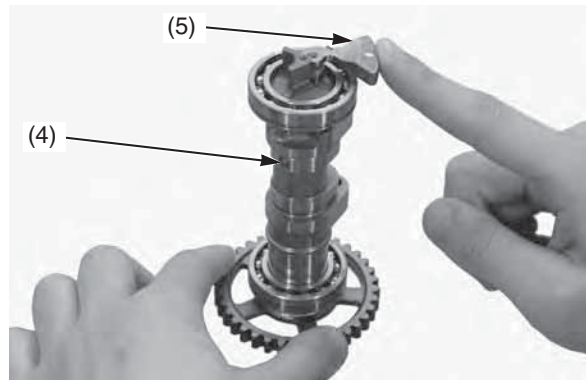

(4) plunger  
(5) decompressor weight

If the operation is not smooth, refer to an official Honda Service Manual (page 186) for decompressor disassembly or see your dealer.

3. Make sure the piston is at TDC on the compression stroke (page 80).
4. Apply molybdenum disulfide oil (a mixture of 1/2 engine oil and 1/2 molybdenum disulfide grease containing more than 3% molybdenum disulfide additive Moly Paste 77) to the following parts.
  - camshaft cam lobes
  - plunger whole surface
5. Install the camshaft (6) onto the cylinder head with the decompressor weight (5) facing up as illustrated below.
6. Install the cam chain (7) over the cam sprocket (8).

While holding the left camshaft bearing (9) to the left fully, install the camshaft (6) onto the cylinder head (10) and slide the left camshaft bearing to the right fully.

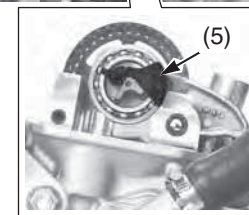
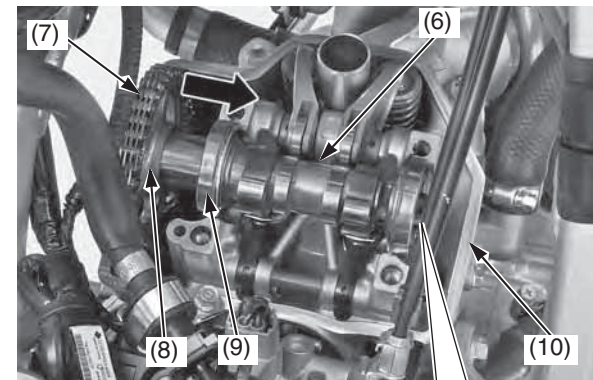

(5) decompressor weight  
(6) camshaft  
(7) cam chain  
(8) cam sprocket  
(9) left camshaft bearing  
(10) cylinder head



7. Make sure that the timing mark (11) on the cam sprocket aligns with the camshaft holder mating surface (12) of the cylinder head.

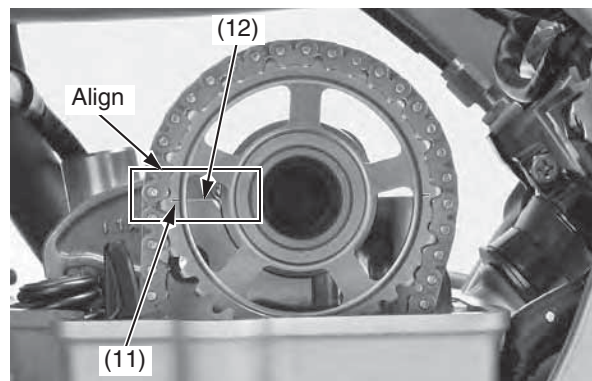

(11) timing mark  
(12) camshaft holder mating surface

8. Make sure that the dowel pins (13) are installed into the camshaft holder (14).

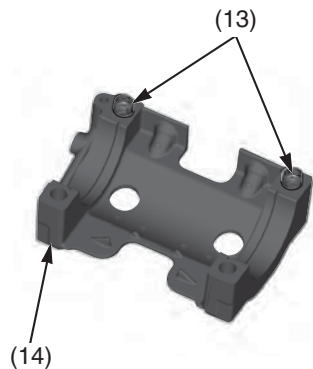

(13) dowel pins (14) camshaft holder

9. Install the set rings (15) on the camshaft bearing grooves (16).

### NOTICE

*Do not let the set rings fall into the crankcase.*

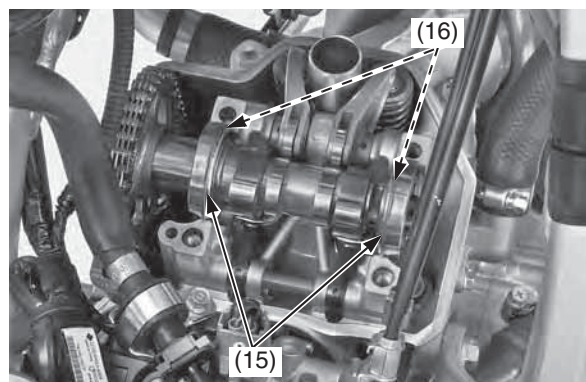

(15) set rings  
(16) camshaft bearing grooves

10. Apply engine oil to the camshaft holder bolt threads.  
Install the camshaft holder (17) with the “ $\Delta$ ” mark (18) facing forward.  
Install the camshaft holder bolts (19) (20) and tighten the camshaft holder bolts to the specified torque:  
11 lbf·ft (15 N·m, 1.5 kgf·m)

Tighten the camshaft holder bolts in a crisscross pattern in two or three steps.

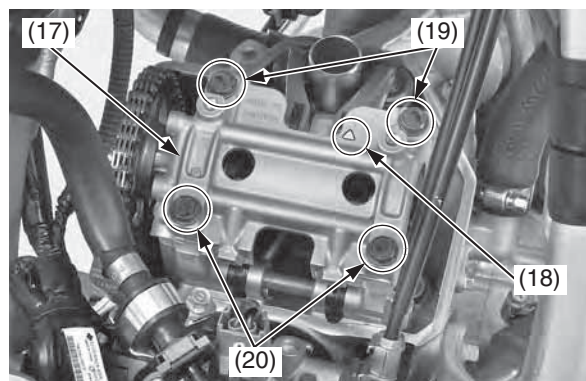

(17) camshaft holder (19) camshaft holder bolts (long)  
(18) “ $\Delta$ ” mark (20) camshaft holder bolts (short)

11. Remove the tensioner stopper (21) from the cam chain tensioner lifter.

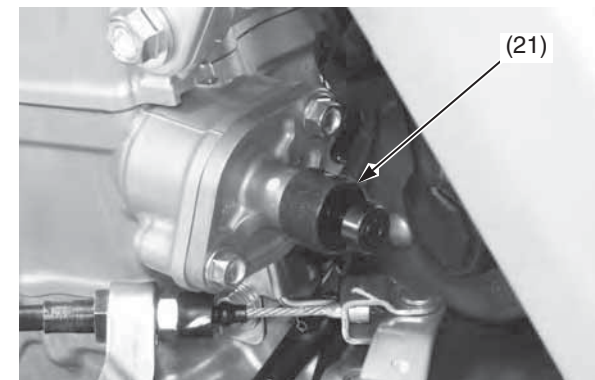

(21) tensioner stopper

12. Make sure that the piston is at TDC on the compression stroke (page 80).  
Check that the timing mark (11) on the cam sprocket aligns with the camshaft holder mating surface (12) of the cylinder head.

If the timing mark doesn't align with the camshaft holder mating surface, insert the tensioner stopper into the cam chain tensioner lifter (page 82) and then remove the cam chain and realign the timing mark.

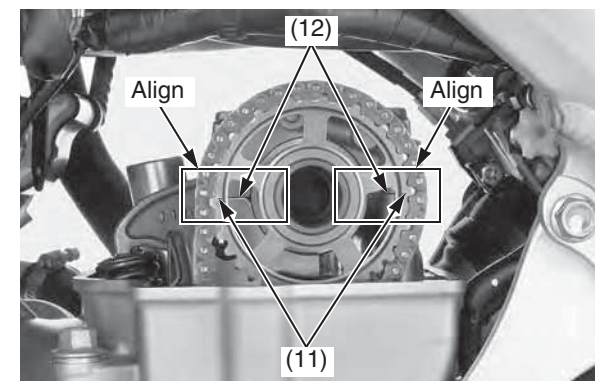

(11) timing mark  
(12) camshaft holder mating surface

(cont'd)

## Valve Clearance

13. Check that “T” mark (22) on the primary drive gear (23) aligns with the index mark (24) on the right crankcase cover.

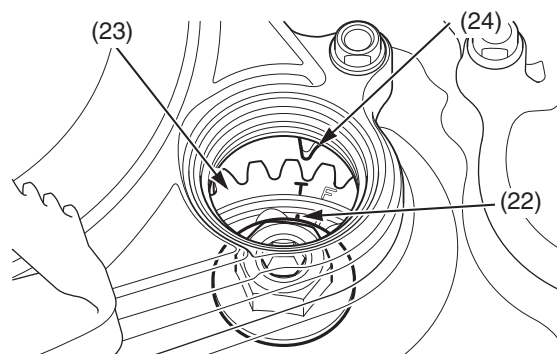

(22) “T” mark  
(23) primary drive gear  
(24) index mark

14. Rotate the camshaft by rotating the crankshaft clockwise several times.  
Make sure the piston is at TDC on the compression stroke (page 80).

15. Measure the intake and exhaust valve clearances by inserting a feeler gauge (25).  
Valve Clearance:

IN:  $0.005 \pm 0.001$  in ( $0.13 \pm 0.03$  mm)

EX:  $0.011 \pm 0.001$  in ( $0.28 \pm 0.03$  mm)

Intake side:

Exhaust side:

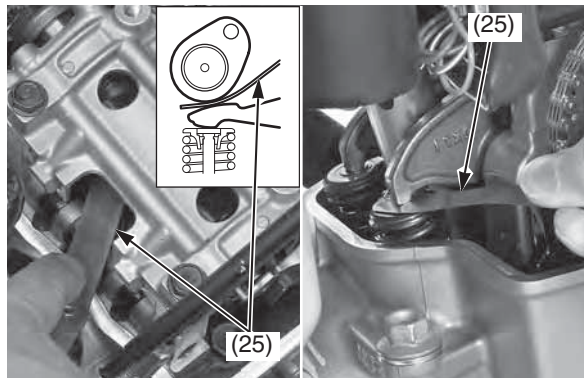

(25) feeler gauge

16. Install a new sealing washer (26) and tighten the cam chain tensioner lifter cover bolt (27).

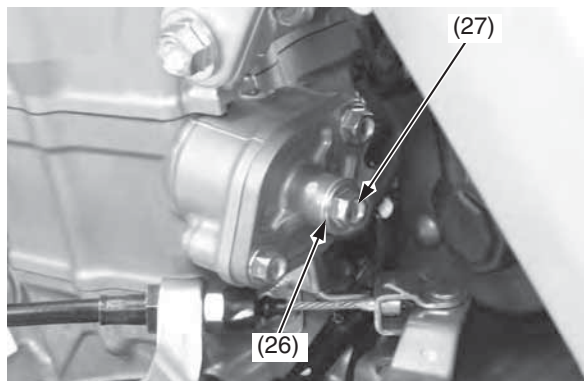

(26) sealing washer (new)  
(27) cam chain tensioner lifter cover bolt

## Crankshaft Hole Cap Installation

1. Install the spark plug (page 78).
2. Coat a new O-ring (1) with engine oil and install it onto the crankshaft hole cap (2). Apply grease to the crankshaft hole cap threads. Install and tighten the crankshaft hole cap to the specified torque:  
11 lbf-ft (15 N·m, 1.5 kgf-m)

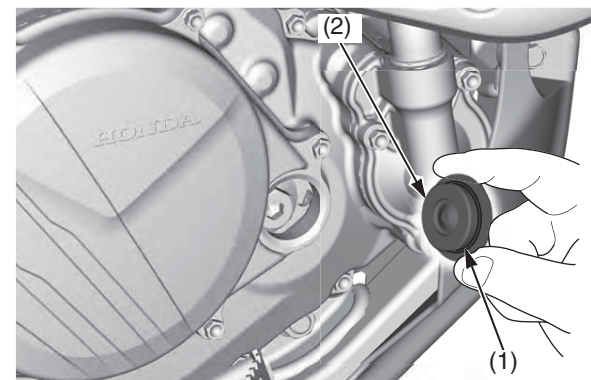

(1) O-ring (new)  
(2) crankshaft hole cap

## Cylinder Head Cover Installation

1. Check that the spark plug hole packing (1) is in good condition and replace it if necessary. Apply engine oil to the spark plug hole packing and install it to the cylinder head cover (2).
2. Check that the cylinder head cover packing (3) is in good condition and replace it if necessary. Clean and apply liquid sealant (TB1207B or equivalent) to the cylinder head cover groove (4) in the shown and install the cylinder head cover packing into the cylinder head cover groove.

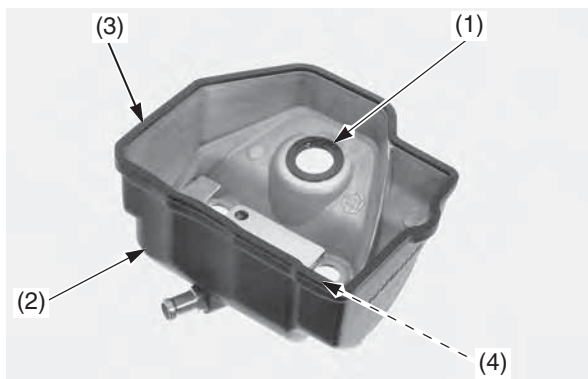

- (1) spark plug hole packing
- (2) cylinder head cover
- (3) cylinder head cover packing
- (4) cylinder head cover groove

3. Check that the rubber seals (5) are in good condition, replace them if necessary. Install the rubber seals onto the cylinder head cover with the “UP” marks (6) facing up.

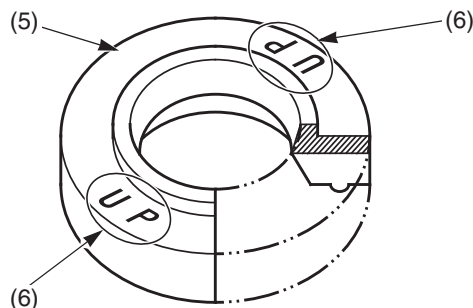

- (5) rubber seals
- (6) “UP” marks

4. Install the cylinder head cover (2) and tighten the cylinder head cover socket bolts (7) to the specified torque:  
7 lbf·ft (10 N·m, 1.0 kgf·m)

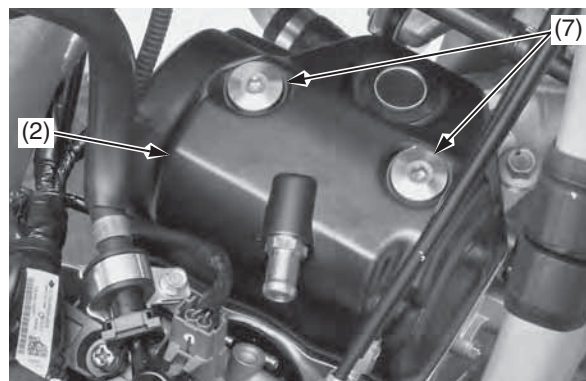

- (2) cylinder head cover
- (7) cylinder head cover socket bolts

5. Connect the spark plug cap (8) and breather tube (9).

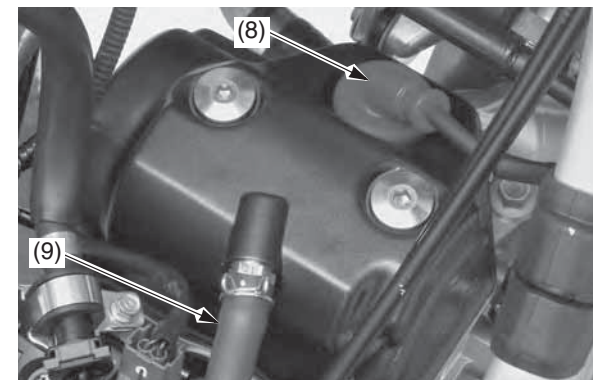

- (8) spark plug cap
- (9) breather tube

6. Install the fuel tank and seat (pages 34, 36, 38).



# Piston/Piston Rings/Piston Pin

Refer to *Important Safety Precautions* on page 23.

## Cylinder Head Removal

1. Clean the area above the engine before disassembly to prevent dirt falling into the engine.
2. Drain the radiator coolant after cooling the motorcycle (page 163).
3. Remove the seat and hang the fuel tank to the left of the frame (pages 34, 35, 37).
4. Remove the left and right mufflers (page 126).
5. Remove the exhaust pipe (page 129).
6. Remove the subframe (page 39).
7. Remove the spark plug (page 78).
8. Remove the cylinder head cover (page 79).
9. Set the piston at TDC on the compression stroke (page 80).
10. Remove the camshaft holder, camshaft and shims (page 81).
11. Disconnect the ignition coil A connector (1) and B connector (2). Remove the ignition coil (3) by removing the ignition coil bolts (4).

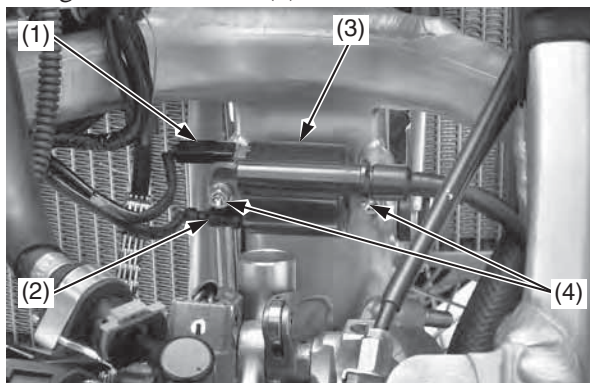

(1) ignition coil A connector      (3) ignition coil  
(2) ignition coil B connector      (4) ignition coil bolts

12. Disconnect the ECT sensor connector (5).

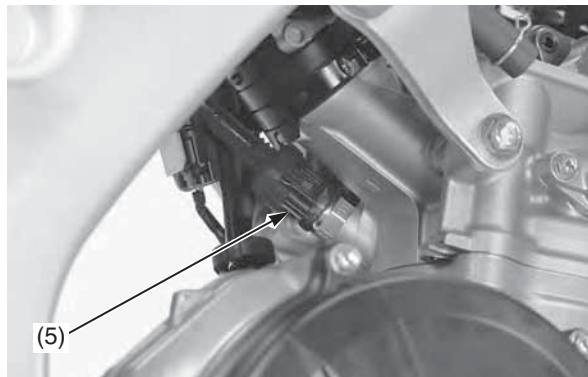

(5) ECT sensor connector

13. Loosen the radiator hose clamp screw (6) and disconnect the radiator hose (7).
14. Remove the right radiator lower mounting bolt (8) and washer (9).

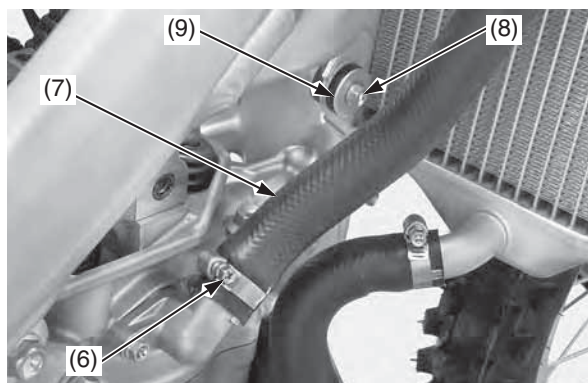

(6) radiator hose clamp screw  
(7) radiator hose  
(8) right radiator lower mounting bolt  
(9) washer

15. Loosen the insulator band screw (10) and pull the throttle body (11) out from the insulator (12).

Do not hang the throttle body and support it with a suitable strap.

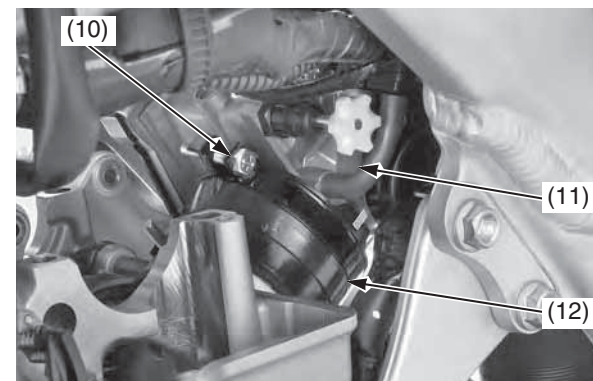

(10) insulator band screw  
(11) throttle body  
(12) insulator

16. Remove the cylinder head hanger bolts (13). Remove the cylinder head hanger plate bolts (14), left cylinder head hanger plate (15) and right cylinder head hanger plate (16).

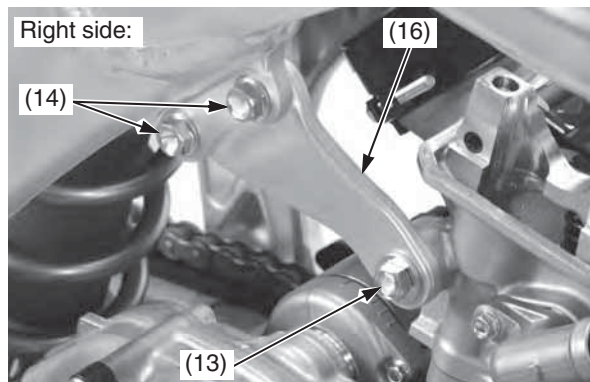
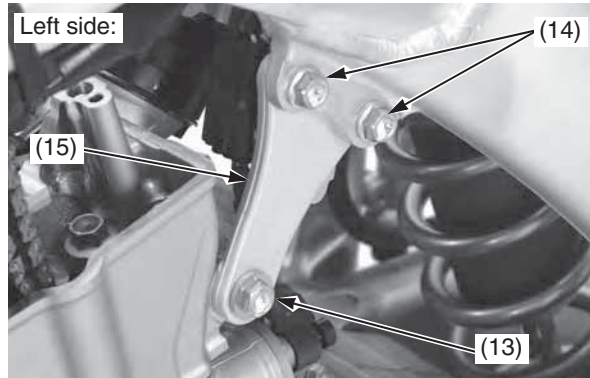

- (13) cylinder head hanger bolts  
(14) cylinder head hanger plate bolts  
(15) left cylinder head hanger plate  
(16) right cylinder head hanger plate

17. Remove the cylinder bolt (17).  
18. Remove the cylinder head bolts, washers (18) and cylinder head (19).

Loosen the bolts in a crisscross pattern in two or three steps.

### NOTICE

*Do not let the washers and cam chain fall into the crankcase.*

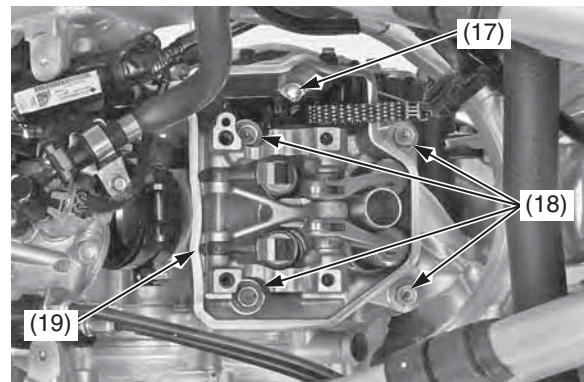

- (17) cylinder bolt  
(18) cylinder head bolts and washers  
(19) cylinder head

19. Remove the dowel pins (20) and cylinder head gasket (21).

### NOTICE

*Do not let the dowel pins and cam chain fall into the crankcase.*

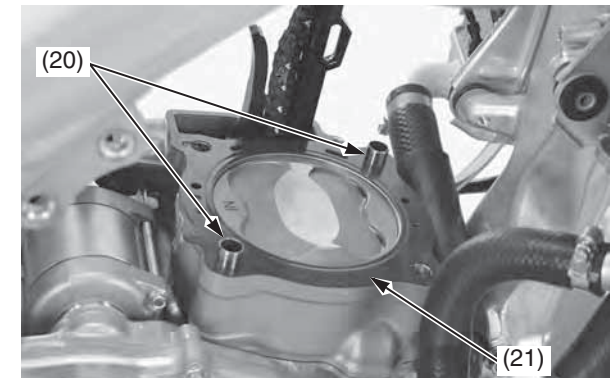

- (20) dowel pins  
(21) cylinder head gasket

20. Remove the cam chain guide (22) from the cylinder (23).

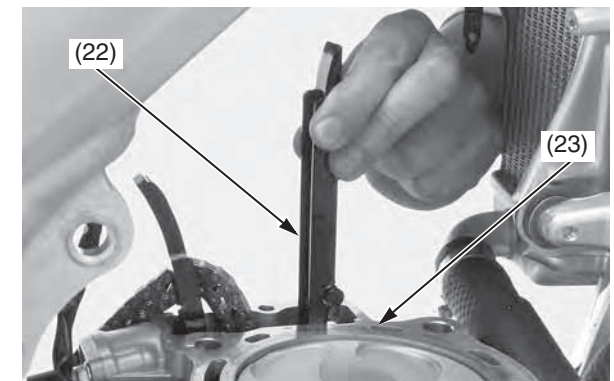

- (22) cam chain guide  
(23) cylinder



# Piston/Piston Rings/Piston Pin

## Cylinder Removal

1. Remove the cylinder (1) while holding the piston (2).

### NOTICE

*Do not let the cam chain fall into the crankcase.  
Do not pry on or strike the cylinder.*

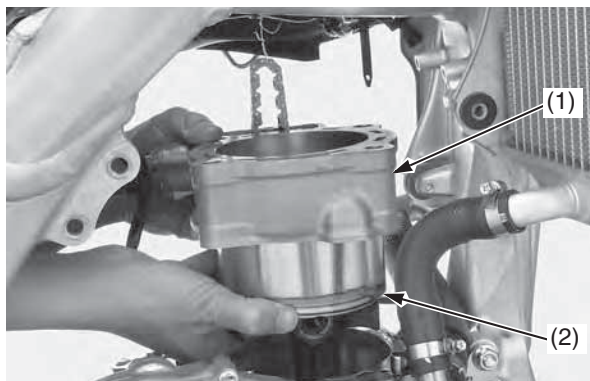

(1) cylinder (2) piston

2. Remove the dowel pins (3) and cylinder gasket (4).

### NOTICE

*Do not let the cam chain fall into the crankcase.  
Do not let the dowel pins fall into the crankcase.*

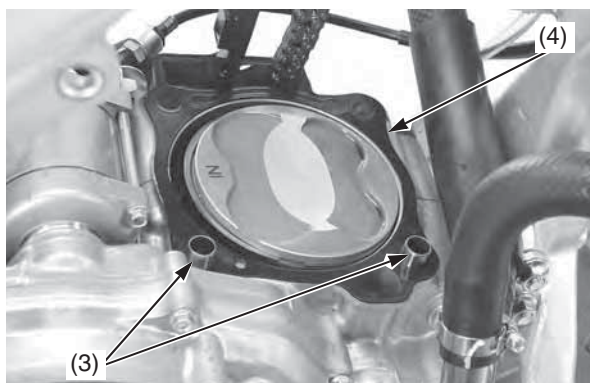

(3) dowel pins (4) cylinder gasket

## Piston Removal

1. Place clean shop towels (1) in the crankcase to keep the piston pin clips, or other parts, from falling into the crankcase.
2. Remove the piston pin clips (2) using a pair of needle-nose pliers.
3. Press the piston pin (3) out of the piston (4), and remove the piston.

(CRF450RX)

Under racing conditions, the piston, rings and piston pin should be replaced every 4 races or about every 15.0 hours of running.

(CRF450R/RWE)

Under racing conditions, the piston, rings and piston pin should be replaced every 6 races or about every 15.0 hours of running.

### NOTICE

*Be careful not to damage or shock the piston pin.  
Do not clean the piston pin using a commercially available compound cleaner.*

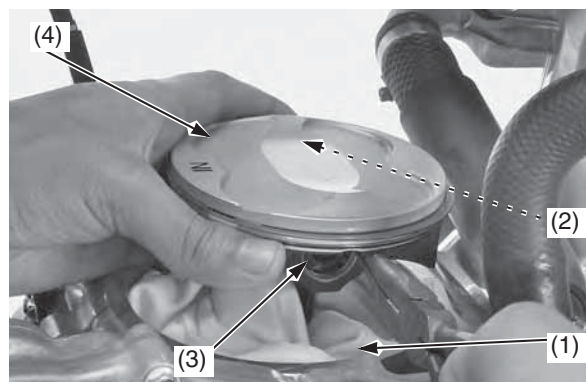

(1) shop towels (2) piston pin clips  
(3) piston pin (4) piston

## Piston Ring Removal

Spread each piston ring (1) and remove by lifting it up at a point just opposite the gap.

### NOTICE

*Do not damage the piston ring by spreading the ends too far.*



(1) piston ring

## Piston/Piston Pin/Piston Ring Inspection

We recommend you consult an official Honda Service Manual or your dealer for correct Service Limit measurements.

## Piston Ring Installation

1. Remove the carbon deposits from the piston head and piston ring grooves.

### NOTICE

*Do not damage the piston when removing the carbon deposit.*

2. Apply engine oil to each piston ring whole surface.
3. Install the spacer (1) first, then install the side rails (2) to the piston (3).
4. Install the top ring (4) to the piston with "1R" mark (5) side facing up.

### NOTICE

*Do not damage the piston ring by spreading the ends too far.*

*Do not damage the piston during piston ring installation.*

5. After installing the piston rings they should rotate freely, without sticking. Space the ring end gaps 180 degrees apart between top ring and upper side rail. Space the ring end gaps 90 degrees apart between upper side rail, spacer and lower side rail.

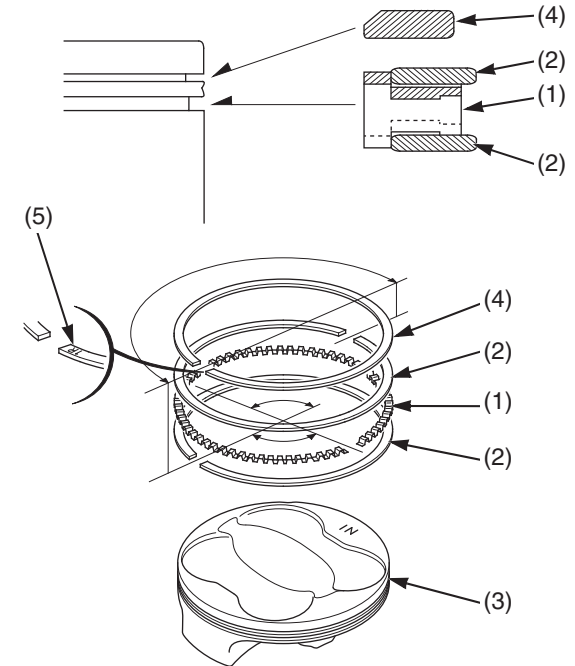

(1) spacer  
(2) side rails  
(3) piston

(4) top ring  
(5) "1R" mark

# Piston/Piston Rings/Piston Pin

## Piston Installation

1. Place clean shop towels (1) over the crankcase opening to keep the piston pin clips from falling into the crankcase.
2. Apply molybdenum disulfide oil (a mixture of 1/2 engine oil and 1/2 molybdenum disulfide grease containing more than 3% molybdenum disulfide additive Moly Paste 77) to the connecting rod small end (2) inner surface.

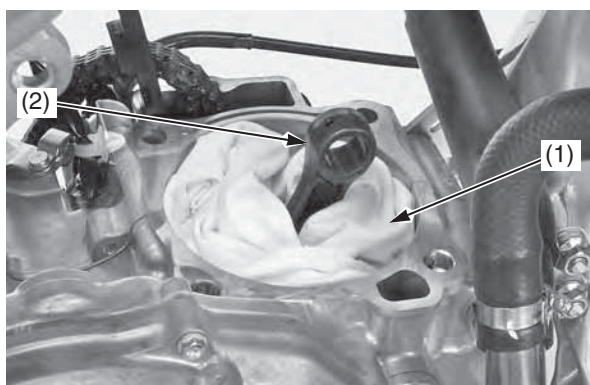

(1) shop towels  
(2) connecting rod small end

3. Install the piston (3) with the "IN" mark (4) and/or the large valve recesses (5) facing the intake side of the engine.

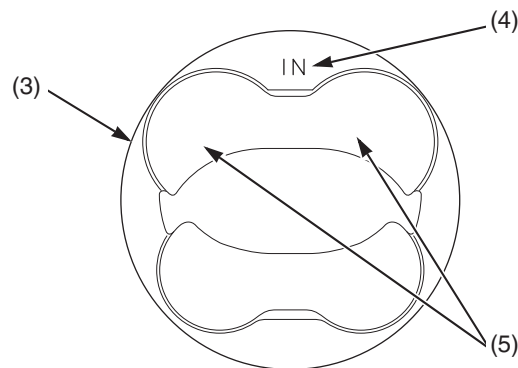

(3) piston  
(4) "IN" mark  
(5) large valve recesses

Apply molybdenum disulfide oil (a mixture of 1/2 engine oil and 1/2 molybdenum disulfide grease containing more than 3% molybdenum disulfide additive Moly Paste 77) to the piston pin (6) outer surface. Apply engine oil to the piston outer surface and piston pin hole inner surface. Install the piston pin and new piston pin clips (7).

### NOTICE

*Be careful not to damage or shock the piston pin. Use new pin clips. Never reuse old clips. Do not let the clips fall into the crankcase. Do not align the piston pin clip end gap with the piston cutout (8).*

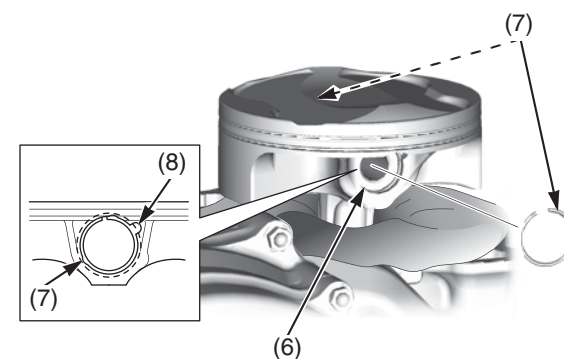

(6) piston pin  
(7) piston pin clips (new)  
(8) piston cutout

## Cylinder Installation

1. Clean the cylinder mating surfaces (1) of the crankcase, being careful not to let any material fall into the crankcase.
2. Remove the shop towels.
3. Apply liquid sealant (TB1141G manufactured by ThreeBond or equivalent) to the cylinder mating surface of the crankcase side as shown.

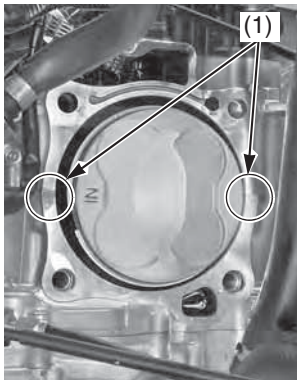

(1) cylinder mating surface

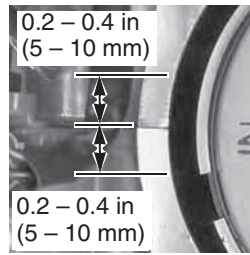

4. Install the dowel pins (2) and a new cylinder gasket (3).

### NOTICE

*Do not let the dowel pins fall into the crankcase.*

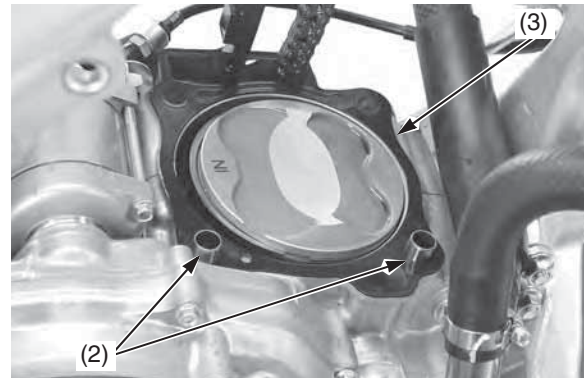

(2) dowel pins

(3) cylinder gasket (new)

5. Apply engine oil to the cylinder bore (4), piston outer surface and piston rings (5). Route the cam chain (6) through the cylinder. Install the cylinder over the piston rings by hand while compressing the piston rings.

### NOTICE

*Do not damage the piston rings and cylinder bore.  
Do not let the cam chain fall into the crankcase.*

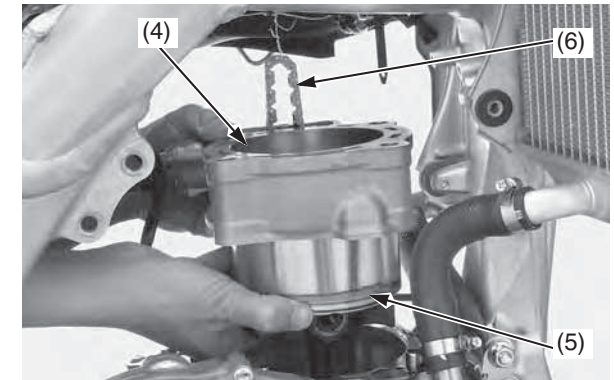

(4) cylinder bore  
(5) piston rings

(6) cam chain



# Piston/Piston Rings/Piston Pin

## Cylinder Head Installation

1. Clean any gasket material off cylinder head.
2. Install the cam chain guide (1) and fit the cam chain guide tabs (2) in the cylinder cutouts (3). Push the guide until it bottoms in the crankcase guide groove.

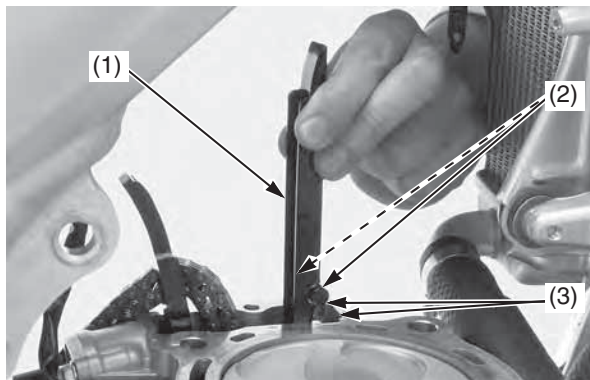

(1) cam chain guide      (3) cylinder cutouts  
(2) cam chain guide tabs

3. Install the dowel pins (4) and a new cylinder head gasket (5).

### NOTICE

*Do not let the dowel pins fall into the crankcase.*

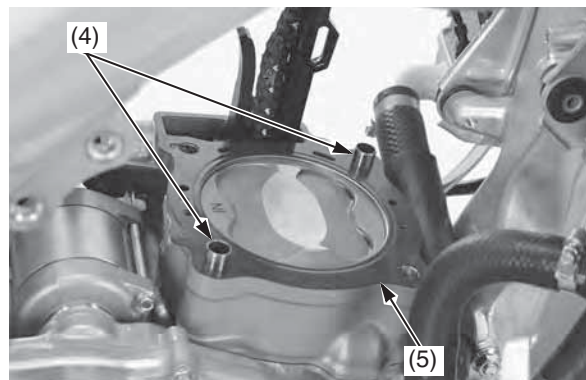

(4) dowel pins  
(5) cylinder head gasket (new)

4. Route the cam chain through the cylinder head and install the cylinder head (6).

### NOTICE

*Do not damage mating surfaces when installing the cylinder head.*

5. Apply engine oil to all cylinder head bolt threads and seating surface. Install the washers and cylinder head bolts (7) and tighten them to the specified torque in a crisscross pattern in two or three steps: 37 lbf-ft (50 N·m, 5.1 kgf-m)

### NOTICE

*Do not let the washers fall into the crankcase.*

6. Install the cylinder bolt (8) and tighten it to the specified torque:  
7 lbf-ft (10 N·m, 1.0 kgf-m)

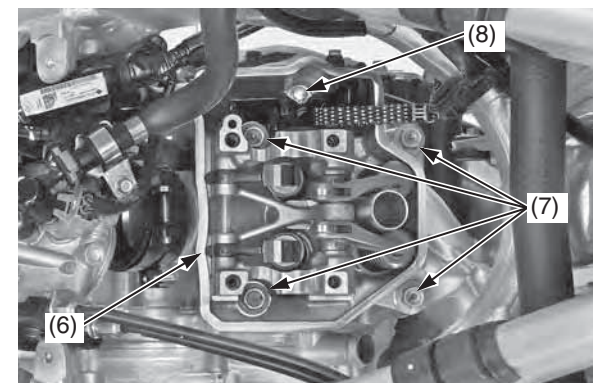

(6) cylinder head  
(7) washers and cylinder head bolts  
(8) cylinder bolt



7. Install the left cylinder head hanger plate (9) and right cylinder head hanger plate (10), then loosely install the cylinder head hanger plate bolts (11) and cylinder head hanger bolts (12). Tighten the cylinder head hanger bolts and cylinder head hanger plate bolts to the specified torque:

cylinder head hanger bolts:  
40 lbf·ft (54 N·m, 5.5 kgf·m)  
cylinder head hanger plate bolts:  
24 lbf·ft (32 N·m, 3.3 kgf·m)

Left side:

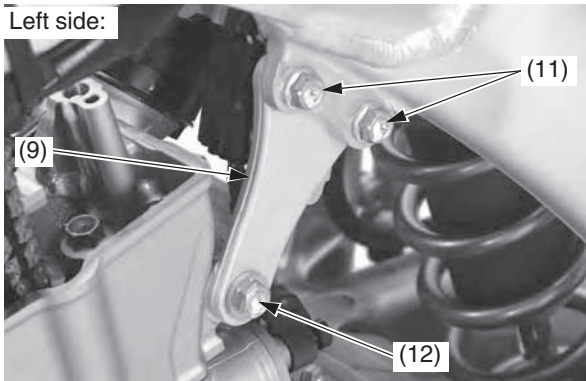

Right side:

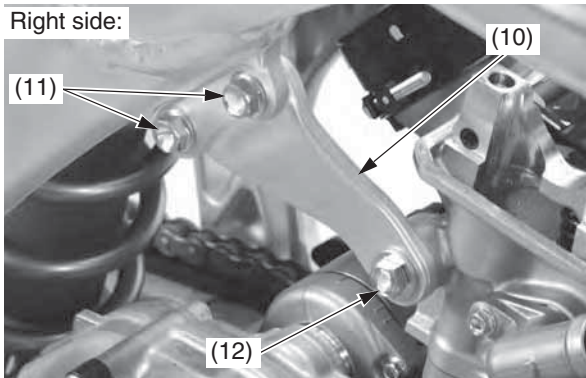

- (9) left cylinder head hanger plate  
(10) right cylinder head hanger plate  
(11) cylinder head hanger plate bolts  
(12) cylinder head hanger bolts

8. Install the throttle body (13) to the insulator (14) by aligning the tab of the throttle body with the groove of the insulator and tighten the insulator band screw (15) so the distance between the band ends is  $0.43 \pm 0.04$  in ( $11.0 \pm 1.0$  mm).

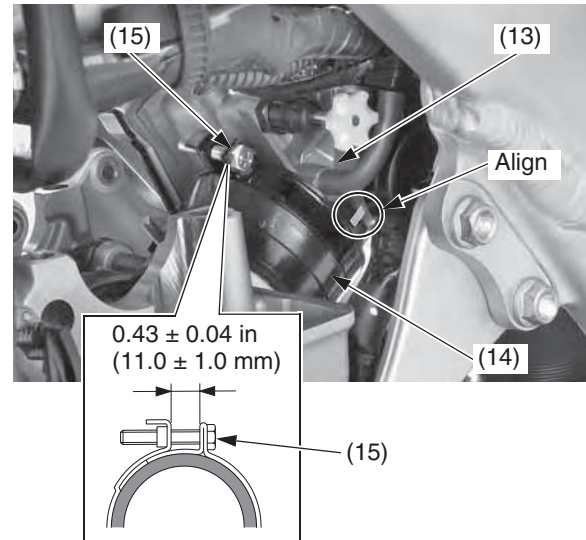

- (13) throttle body  
(14) insulator  
(15) insulator band screw

9. Install and tighten the washer (16) and right radiator lower mounting bolt (17) securely.  
10. Connect the radiator hose (18) to the water hose joint (19) of the cylinder head as shown.

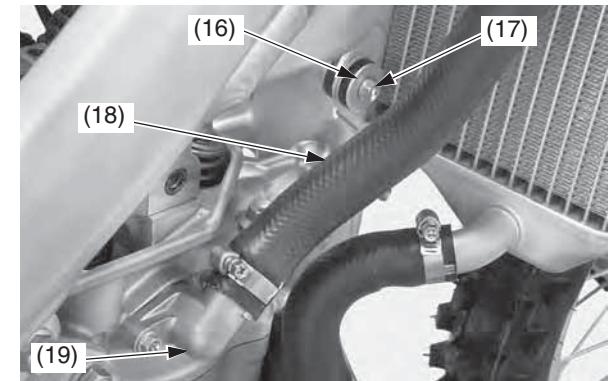

- (16) washer  
(17) right radiator lower mounting bolt  
(18) radiator hose  
(19) water hose joint

11. Tighten the radiator hose clamp screw (20) as illustrated below.

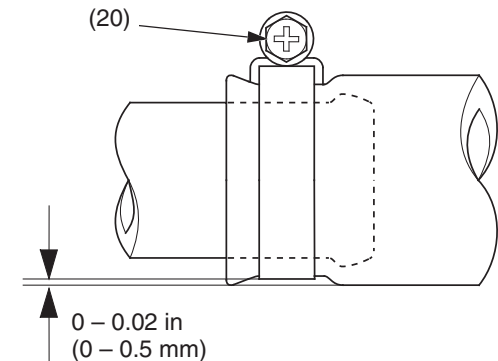

- (20) radiator hose clamp screw

(cont'd)

## Piston/Piston Rings/Piston Pin

12. Connect the ECT sensor connector (21).

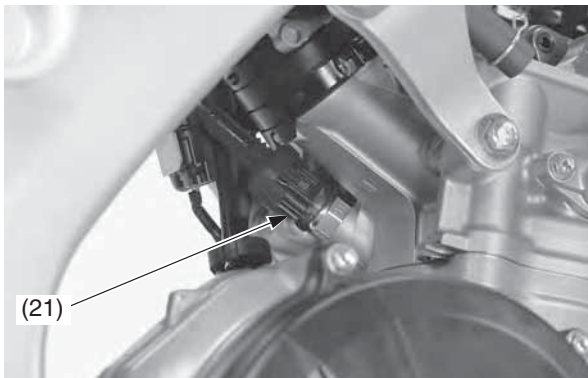

(21) ECT sensor connector

13. Install the ignition coil (22) and tighten the ignition coil bolts (23) to the specified torque: 7 lbf-ft (10 N·m, 1.0 kgf·m)  
Connect the ignition coil A connector (24) and B connector (25).

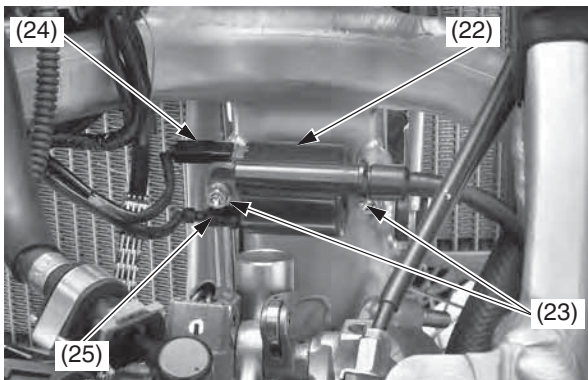

(22) ignition coil  
(23) ignition coil bolts  
(24) ignition coil A connector  
(25) ignition coil B connector

14. Install the shims, camshaft and camshaft holder (page 84).
15. Install the crankshaft hole cap (page 86).
16. Install the cylinder head cover (page 87).
17. Install the spark plug (page 78).
18. Install the exhaust pipe (page 129).
19. Install the subframe (page 40) and left and right mufflers (page 127).
20. Install the fuel tank and seat (pages 34, 36, 38).
21. Fill and bleed the cooling system (page 163).  
Check for the following:
  - compression leaks
  - abnormal engine noise
  - secondary air leaks
  - exhaust gas leaks
  - coolant leaks
  - oil leaks

Refer to *Important Safety Precautions* on page 23.

Loose, worn, or damaged suspension components may adversely affect the handling and stability of your CRF. If any suspension components appear worn or damaged, see your dealer for further inspection. Your dealer is qualified to determine whether or not replacement parts or repairs are needed.

## Front Suspension Inspection

- When your CRF is new, break it in for approximately 1 hour to ensure that the suspension has worked in (page 20).
- After break-in, test run your CRF with the front suspension at the standard setting before attempting any adjustments.
- For optimum fork performance, we recommend that you disassemble and clean the fork after riding your CRF for 3 hours. See page 98 for front suspension removal.
- (CRF450RX)  
Replace the fork oil every 6 races or 22.5 hours of running. See page 100, 101, 105 – 113 for fork oil replacement.
- (CRF450R/RWE)  
Replace the fork oil every 9 races or 22.5 hours of running. See page 100, 101, 105 – 113 for fork oil replacement.

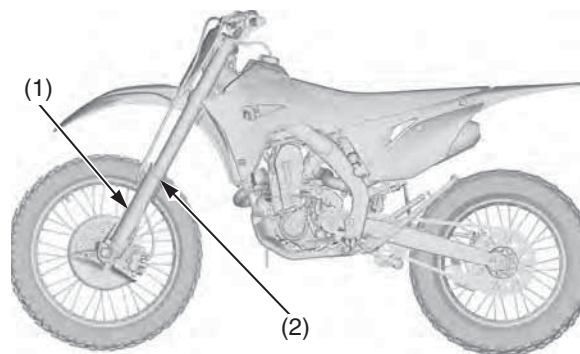

(1) fork protectors

(2) dust seals

- Use Pro Honda HP Fork Oil, A15-00 or an equivalent which contains special additives to assure maximum performance of your CRF's front suspension. Periodically check and clean all front suspension parts to assure top performance. Check the dust seals for dust, dirt, and foreign materials. Check the oil for any contamination.
- Refer to *Suspension Adjustment Guidelines* (page 152). Make all rebound and compression damping adjustments in one-click increments. (Adjusting two or more clicks at a time may cause you to pass over the best adjustment.) Test ride after each adjustment.
- If you become confused about adjustment settings, return to the standard position and start over.
- If the fork is still too stiff/soft after adjusting compression damping, determine which portion of the travel is still too stiff/soft. This is an important step that will help you solve suspension problems.

1. Make sure that the fork protectors (1) and dust seals (2) are clean and not packed with mud and dirt.
2. Check for signs of oil leakage. Damaged or leaking fork seals should be replaced before your CRF is ridden.

3. Inspect the wear rings (3) for wear or damage. Replace the wear ring if it is 0.06 in (1.5 mm) or flush with the outer tube (4). Remove the fork leg when replacing the wear ring (page 98). Install the wear ring with its end gap (5) facing rearward.

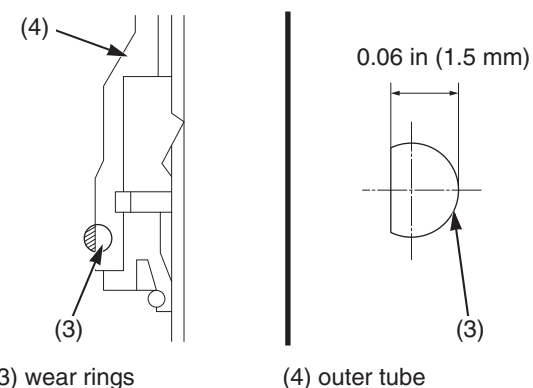

(3) wear rings

(4) outer tube

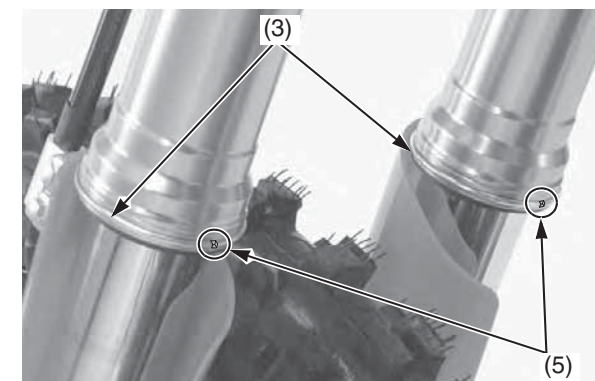

(3) wear rings

(5) end gaps

(cont'd)



# Suspension

4. Make a quick check of fork operation by locking the front brake and pushing down on the handlebar several times.

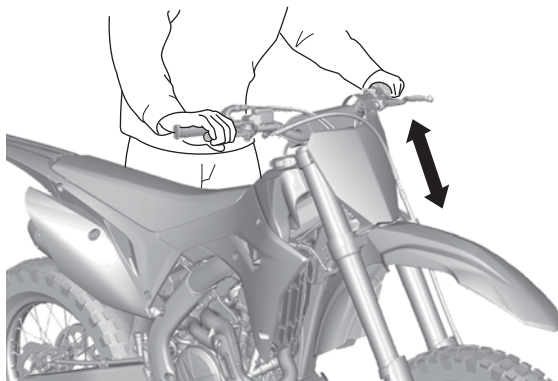

## Front Suspension Removal

- When disassembling the fork, turn the compression (1) and rebound (2) damping adjusters counterclockwise to the softest position to prevent damaging the adjustment needle (be sure to record the number of turns from the starting position).

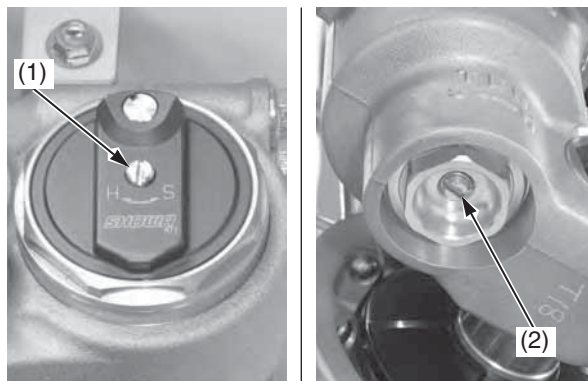

(1) compression damping adjuster  
(2) rebound damping adjuster

1. Unlock the number plate tab (3) from the handlebar. Remove the bolts (4) and number plate (5).

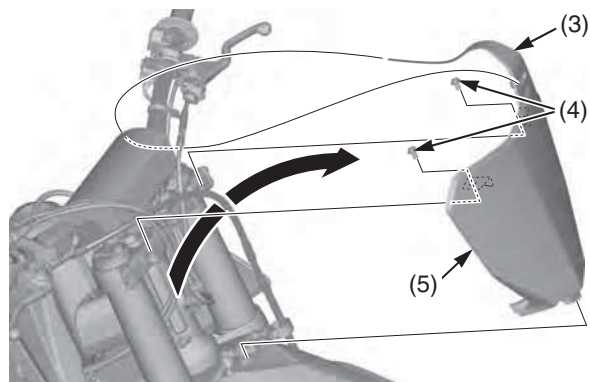

(3) number plate tab (5) number plate  
(4) bolts

2. Place your CRF on an optional workstand or equivalent support with the front wheel off the ground.
3. Remove the handlebar protector, handlebar upper holder bolts (6), handlebar upper holders (7) and handlebar (8).

### NOTICE

*Keep the master cylinder upright to prevent air from entering system.*

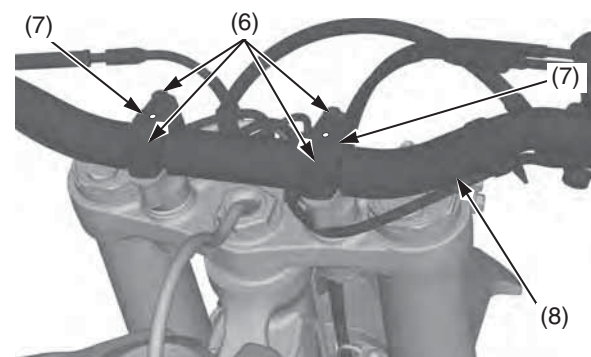

(6) handlebar upper holder bolts  
(7) handlebar upper holders  
(8) handlebar

4. Loosen the fork bridge upper pinch bolts (9).
5. Loosen the fork bolts assembly (10), but do not remove them yet.

6. Loosen the fork damper assembly (11) using the lock nut wrench (12), but do not remove them.

- Lock nut wrench 07WMA-KZ30100

## NOTICE

*Do not use an adjustable wrench to loosen the fork damper: it may damage them.*

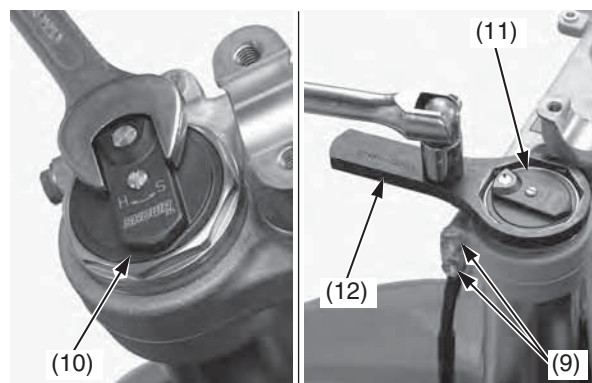

- (9) fork bridge upper pinch bolts
- (10) fork bolt assembly
- (11) fork damper assembly
- (12) lock nut wrench

7. Remove the disc cover (13) by removing disc cover socket bolts (14).

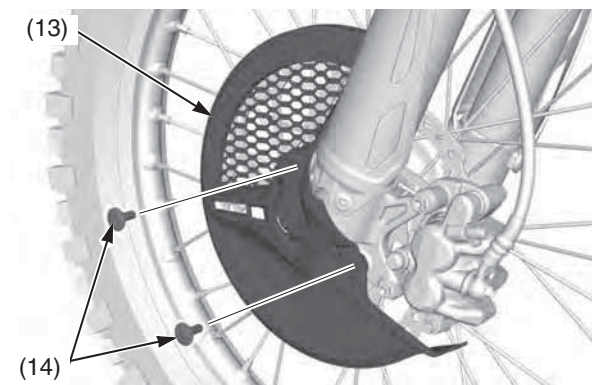

- (13) disc cover
- (14) disc cover socket bolts

8. Remove the front axle nut (15) and loosen the axle pinch bolts (16) on both forks. Pull the front axle shaft (17) out of the wheel hub and remove the front wheel with collars (18).

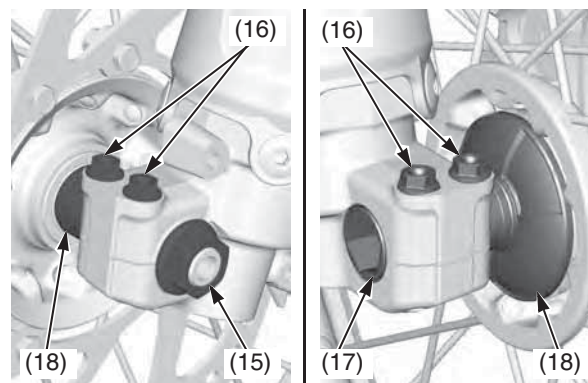

- (15) front axle nut
- (16) axle pinch bolts
- (17) front axle shaft
- (18) collars

9. Remove the brake hose clamp bolts (19), stay A (20) and stay B (21).

10. Remove the front brake caliper mounting bolts (22) and brake caliper (23).

- Do not support the brake caliper by the brake hose.
- Do not operate the brake lever after the front wheel is removed. To do so will cause difficulty in fitting the brake disc between the brake pads.

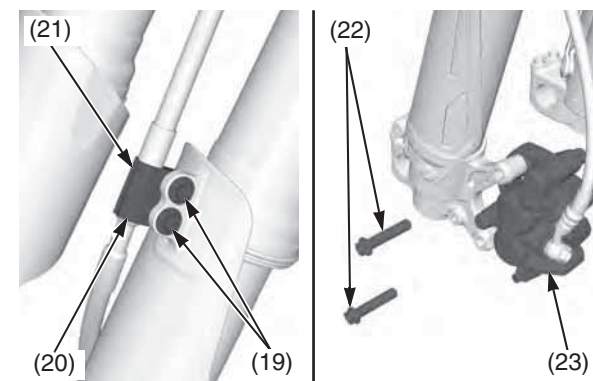

- (19) brake hose clamp bolts
- (20) stay A
- (21) stay B
- (22) front brake caliper mounting bolts
- (23) brake caliper

11. Remove the fork protector socket bolts (24) and fork protectors (25).

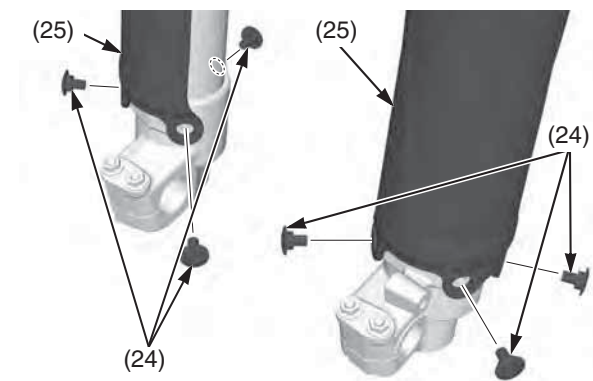

- (24) fork protector socket bolts
- (25) fork protectors

(cont'd)



# Suspension

12. Loosen the fork bridge lower pinch bolts (26), then pull the fork legs down and out.

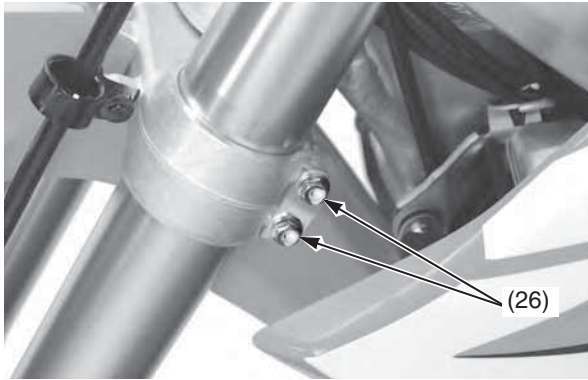

(26) fork bridge lower pinch bolts

13. Clean the fork assembly, especially the sliding surface (27) of the slider and fork dust seal (28).  
 14. Measure the length (29) between the axle holder and outer tube and record it before disassembling the fork.

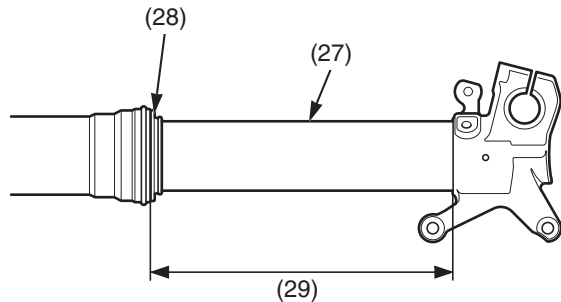

(27) sliding surface  
 (28) fork dust seal  
 (29) length

## Recommended Fork Oil

suggested oil	Pro Honda HP Fork Oil, A15-00
---------------	-------------------------------

## Fork Outer Tube Disassembly

Refer to *Front Suspension Removal* on page 98.

1. Clean the fork assembly, especially the sliding surface of the slider and dust seal.
  2. Hold the outer tube (1), then remove the fork damper assembly (2) from the outer tube using the lock nut wrench (3). Gently slide the outer tube down onto the lower end (axle holder) (4).
- Lock nut wrench 07WMA-KZ30100

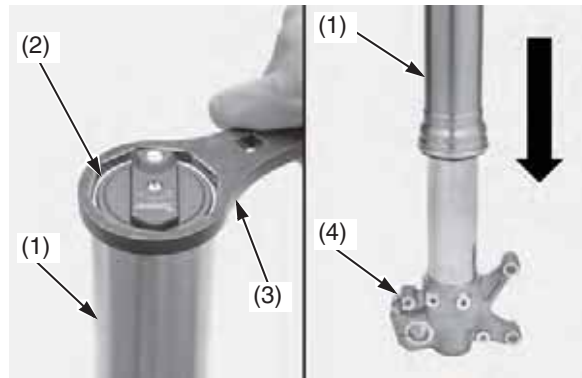

(1) outer tube  
 (2) fork damper assembly  
 (3) lock nut wrench  
 (4) axle holder

## NOTICE

The outer tube (1) can drop on the axle holder (4) and damage the fork dust seal (5). To avoid damage, hold both the outer tube and slider when removing the fork damper.

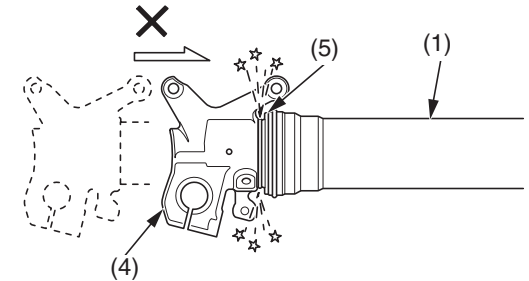

(1) outer tube  
 (4) axle holder  
 (5) fork dust seal

3. Drain the fork oil from the outer tube (1) and oil holes (6) of the fork damper assembly (2). Remove the O-ring (7) from the fork damper assembly.

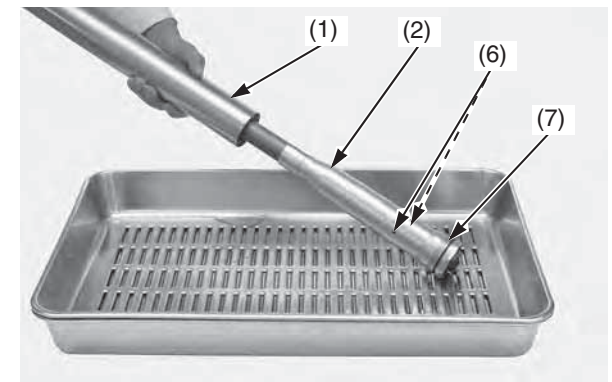

(1) outer tube  
 (2) fork damper assembly  
 (6) oil holes  
 (7) O-ring

- Drain the fork oil by turning the outer tube (1) upside down. (About 0.46 US oz (13.7 cm<sup>3</sup>) of fork oil will be left in the outer tube when it is left inverted for about 20 minutes at 68°F/20°C.)

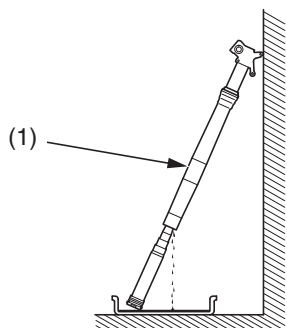

(1) outer tube

Pour the drained oil into a suitable container and dispose of it in an approved manner (page 164).

## NOTICE

*Improper disposal of drained oil is harmful to the environment.*

Amount of fork oil left in the fork (within damper and spring)

unit: cm<sup>3</sup>

minute °C/°F	5	10	20	35	55	85	145
30/86	16.5	14.1	12.7	11.8	11	10.1	8.6
20/68	17.4	15	13.7	12.6	11.5	10.5	9.1
10/50	18.9	16.5	14.8	13.7	12.5	11.4	9.8
0/32	20	18.4	15.9	14.5	13.7	13	11.7

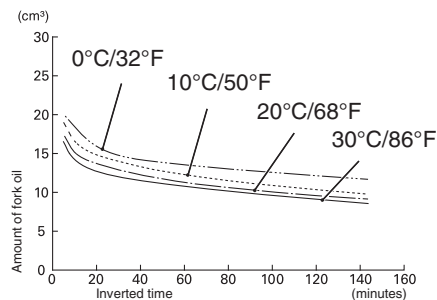

## Fork Oil Refilling

- Pour the recommended fork oil into the outer tube (1).

Be sure the oil capacity is the same in both fork legs.

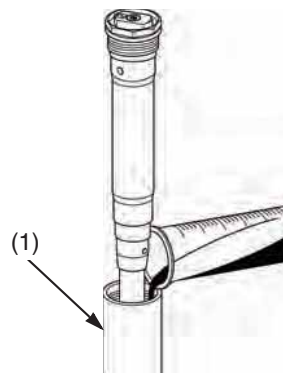

(1) outer tube

Recommended Oil:  
Pro Honda HP Fork Oil, A15-00  
Recommended Standard Amount:  
(CRF450RX)  
12.3 US oz (363 cm<sup>3</sup>)  
(CRF450R/RWE)  
12.0 US oz (356 cm<sup>3</sup>)

Fill the fork oil which is obtained by docking off the amount of the remaining oil in the fork from the recommended standard fork oil capacity.

Refer to *Front Suspension Adjustments* on page 143.

- Apply the recommended fork oil to a new O-ring (2). Install the O-ring on the fork damper assembly (3).

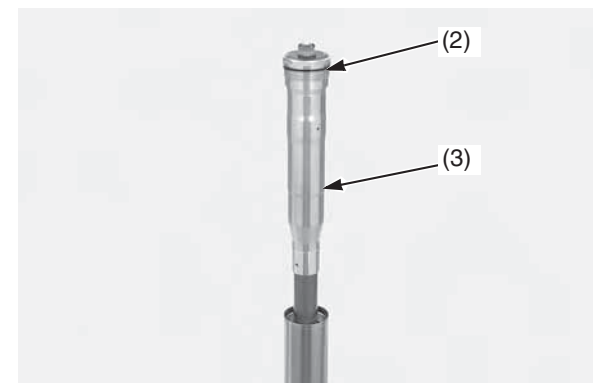

(2) O-ring (new)

(3) fork damper assembly

- Pull up the fork outer tube (1) slowly and temporarily tighten the fork damper assembly (3) using the lock nut wrench (4).

• Lock nut wrench 07WMA-KZ30100

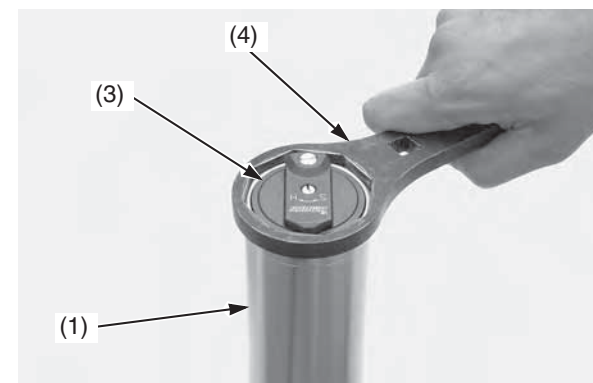

(1) outer tube

(3) fork damper assembly

(4) lock nut wrench

# Suspension

## Front Suspension Installation

1. Insert both fork legs into the fork clamps.  
Tighten the fork bridge lower pinch bolts (1) to the specified torque:  
15 lbf·ft (20 N·m, 2.0 kgf·m)

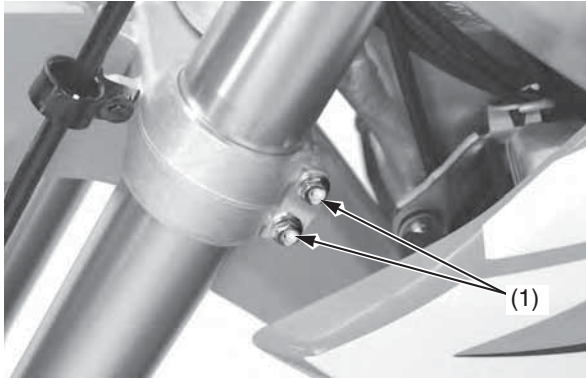

(1) fork bridge lower pinch bolts

2. Tighten the fork damper assembly (2) to the specified torque using the lock nut wrench (3):  
Actual:  
56 lbf·ft (76 N·m, 7.7 kgf·m)  
Torque wrench scale reading:  
51 lbf·ft (69 N·m, 7.0 kgf·m), using a 20 in (500 mm) long deflecting beam type torque wrench.  
• Lock nut wrench 07WMA-KZ30100

When using the lock nut wrench, use a 20 in (500 mm) long deflecting beam type torque wrench. The lock nut wrench increases the torque wrench's leverage, so the torque wrench reading will be less than the torque actually applied to the fork damper assembly.

3. Tighten the fork bolt assembly (4) to the specified torque:  
22 lbf·ft (30 N·m, 3.1 kgf·m)

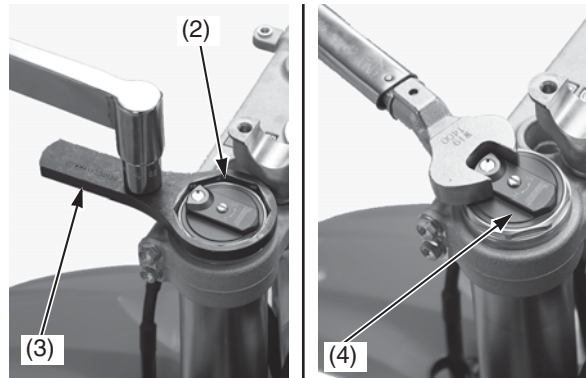

(2) fork damper assembly  
(3) lock nut wrench  
(4) fork bolt assembly

4. For ease of releasing air pressure after the forks are installed, loosen the fork bridge lower pinch bolts (1) and position the outer tubes so that the fork air pressure release screws (5) are in front of the compression damping adjuster (6).

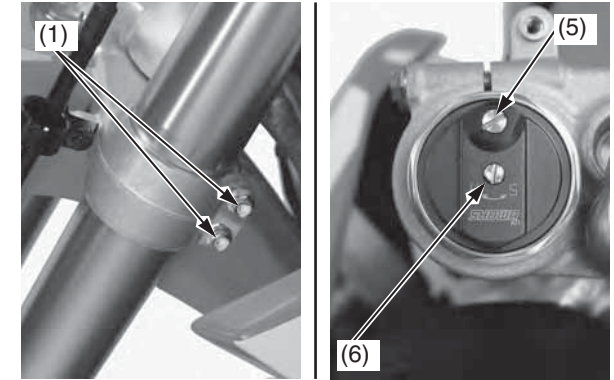

(1) fork bridge lower pinch bolts  
(5) pressure release screw  
(6) compression damping adjuster

5. Align the groove (7) in the outer tube with the top surface of the upper fork bridge (8).

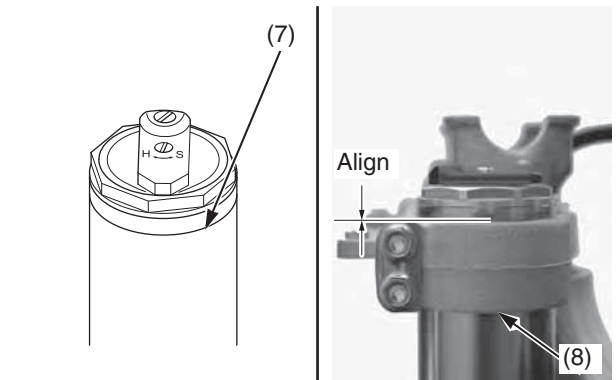

(7) groove

(8) upper fork bridge

6. Tighten the fork bridge lower pinch bolts (1) to the specified torque:  
15 lbf·ft (20 N·m, 2.0 kgf·m)
7. Tighten the fork bridge upper pinch bolts (9) to the specified torque:  
16 lbf·ft (22 N·m, 2.2 kgf·m)

## NOTICE

*Over-tightening the pinch bolts can deform the outer tubes. Deformed outer tubes must be replaced.*

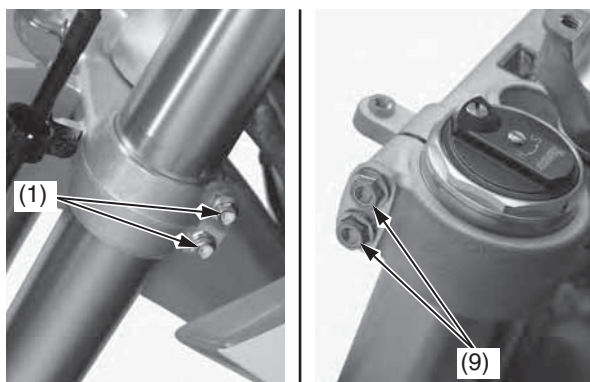

(1) fork bridge lower pinch bolts  
(9) fork bridge upper pinch bolts

8. Clean the threads of the fork protector socket bolts (10) and axle holder thoroughly. Apply locking agent to the bolt threads. Install the fork protectors (11), fork protector socket bolts. Tighten the fork protector socket bolts to the specified torque:  
5.2 lbf·ft (7 N·m, 0.7 kgf·m)

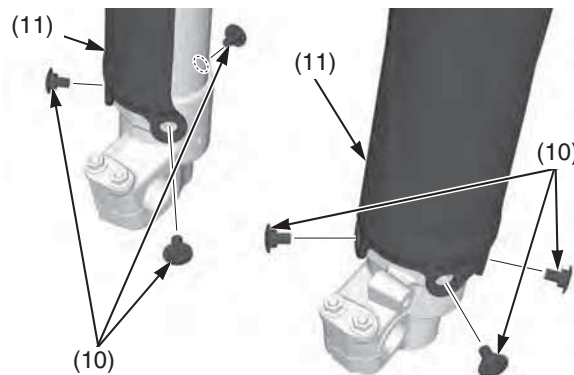

(10) fork protector socket bolts  
(11) fork protectors

9. Align the brake caliper (12) and brake hose (13) with the left fork leg, making sure that the brake hose is not twisted. An improperly routed brake hose may rupture and cause a loss of braking efficiency.
10. Align the lower surface of the brake hose protector (14), stay A (15) and stay B (16), and assemble them. Install and tighten them to the left fork protector using the brake hose clamp bolts (17).

11. Clean the threads of the front brake caliper mounting bolts (18) and brake caliper thoroughly. Apply locking agent to the bolt threads. Install the brake caliper (12) on the axle holder and tighten the front brake caliper mounting bolts to the specified torque:  
22 lbf·ft (30 N·m, 3.1 kgf·m)

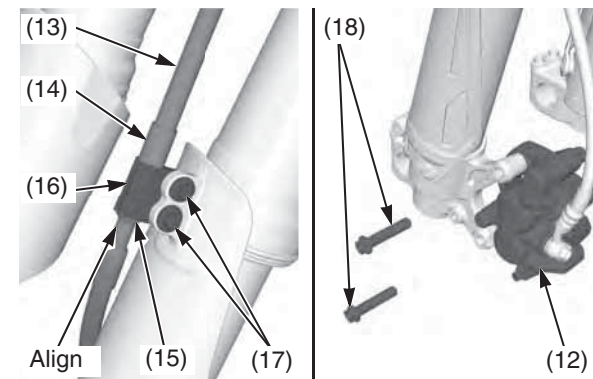

(12) brake caliper  
(13) brake hose  
(14) brake hose protector  
(15) stay A  
(16) stay B  
(17) brake hose clamp bolts  
(18) front brake caliper mounting bolts

(cont'd)



# Suspension

12. Clean the surfaces where the axle and axle clamps contact each other.  
Apply grease to each dust seal lips (19) of the front wheel.  
Install the left side collar (20) and right side collar (21) into the wheel hub.

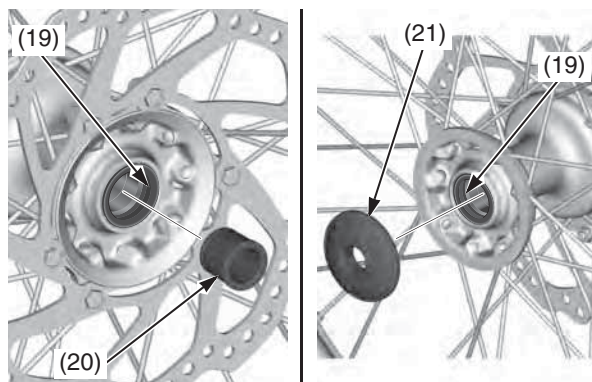

(19) dust seal lips  
(20) left side collar  
(21) right side collar

13. Install the front wheel between the fork legs while inserting the brake disc between the brake pads, being careful not to damage the pads.
14. Insert the front axle shaft (22) through the forks and wheel hub from the right side. Make sure that the front axle shaft is seated firmly onto the left fork leg clamp inner surface. Tighten the front axle nut (23) to the specified torque:  
**65 lbf-ft (88 N·m, 9.0 kgf·m)**  
Tighten the left axle pinch bolts (24) to the specified torque:  
**15 lbf-ft (20 N·m, 2.0 kgf·m)**

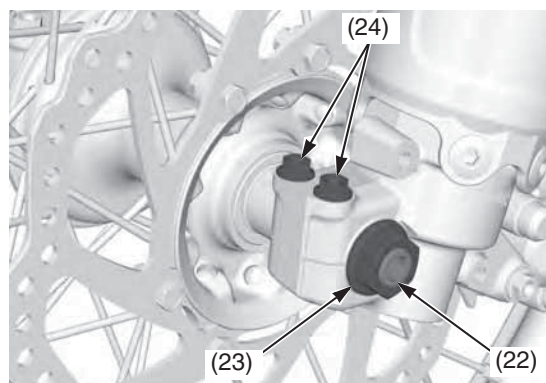

(22) front axle shaft  
(23) front axle nut  
(24) left axle pinch bolts

15. Install the handlebar (25), handlebar upper holders (26) and handlebar upper holder bolts (27) and tighten the handlebar upper holder bolts to the specified torque:  
**16 lbf-ft (22 N·m, 2.2 kgf·m)**

## NOTICE

- *Install the handlebar upper holder with the punch marks (28) facing forward.*
- *Align the paint mark (29) on the handlebar with the end of the left handlebar holders.*
- *First, tighten the bolts on front side of the handlebar upper holders.*

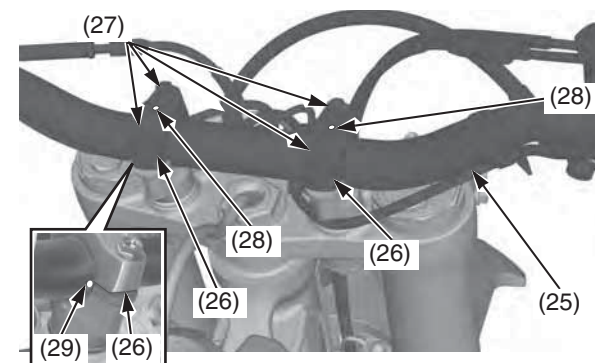

(25) handlebar  
(26) handlebar upper holders  
(27) handlebar upper holder bolts  
(28) punch marks  
(29) paint mark

16. Install the handlebar protector.  
Install the number plate (30) by aligning its tab (31) with the slit (32) on the front fender. Install and tighten the bolts (33).  
Route the number plate tab (34) around the handlebar (35) as shown. Make sure that the brake hose (13) is routed properly in front of the number plate.

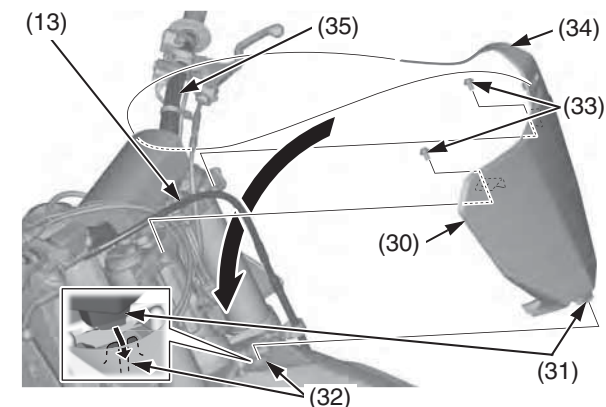

(13) brake hose  
(30) number plate  
(31) tab  
(32) slit  
(33) bolts  
(34) number plate tab  
(35) handlebar



17. With the front brake applied, pump the fork up and down several times to seat the axle and check front brake operation.

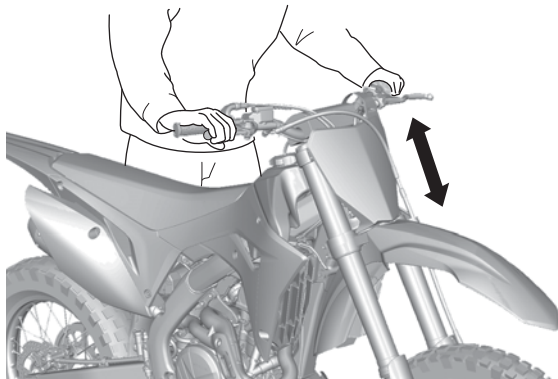

18. While keeping the forks parallel, alternately tighten the right axle pinch bolts (36) to the specified torque:  
15 lbf-ft (20 N·m, 2.0 kgf·m)

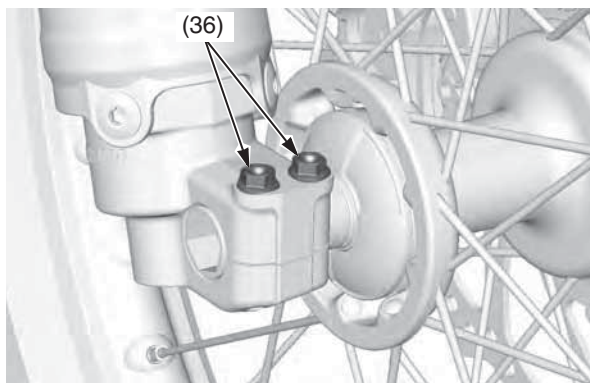

(36) right axle pinch bolts

### NOTICE

*To avoid damage when torquing the axle pinch bolts, be sure the axle is seated firmly onto the left fork leg clamp inner surface.*

19. Install the disc cover (37) and tighten the disc cover socket bolts (38) to the specified torque:  
10 lbf-ft (13 N·m, 1.3 kgf·m)

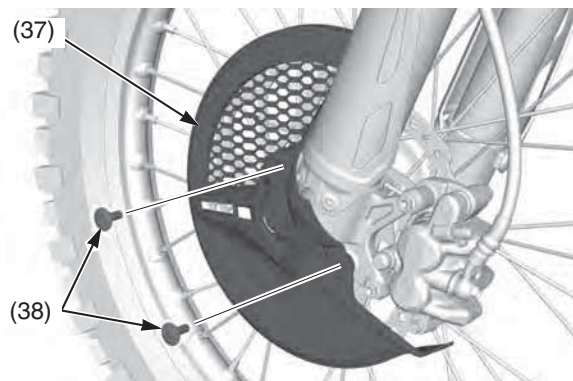

(37) disc cover

(38) disc cover socket bolts

20. Turn the compression damping (39) and rebound damping (40) adjuster screws back to their original settings.

Refer to *Front Suspension Damping* on page 144.

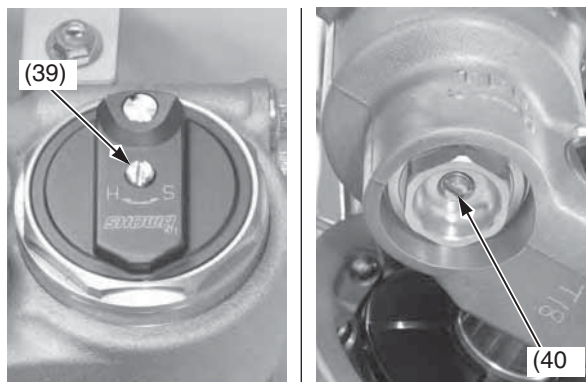

(39) compression damping adjuster

(40) rebound damping adjuster

## Fork Damper Disassembly

1. Remove the front suspension (page 98).
2. Disassemble the fork outer tube (page 100).
3. Place the lower end (axle holder) (1) of the slider in a vise with a piece of wood or soft jaws to avoid damage.

### NOTICE

*Over-tightening the vise can damage the axle holder.*

4. Loosen the fork center bolt (2).

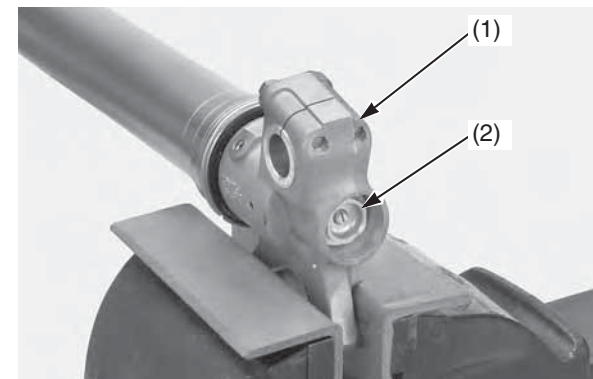

(1) axle holder

(2) fork center bolt

5. Pull up the fork outer tube slowly and temporarily tighten the fork damper assembly (page 101). Push the outer tube until the fork center bolt lock nut (3) is fully exposed and install the piston base (4) or mechanic's stopper tool between the axle holder (1) and fork center bolt lock nut.

• Piston base 07958-2500001

(cont'd)

# Suspension

6. Make the mechanic's stopper tool out of a thin piece of steel (0.08 in (2.0 mm) thick) as shown if you do not have a special tool.

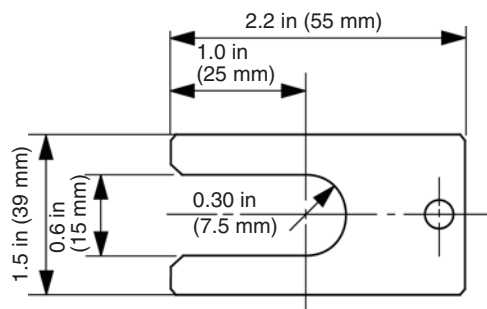

7. Hold the fork center bolt lock nut (3) and remove the fork center bolt (2) from the fork damper.

## NOTICE

*Do not remove the lock nut from the fork damper piston rod. If the lock nut is removed, the piston rod will fall in the fork damper and you may not reassemble the fork damper.*

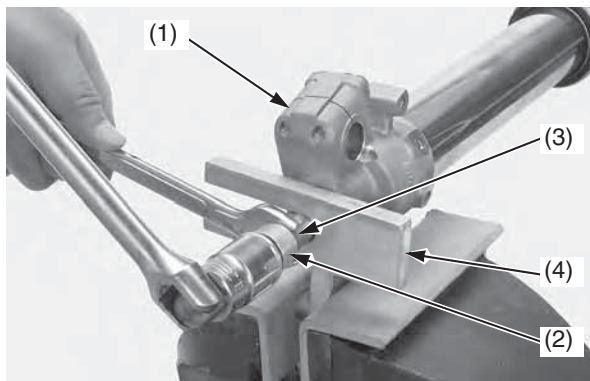

(1) axle holder (3) fork center bolt lock nut  
(2) fork center bolt (4) piston base

8. Remove the push rod (5) from the fork damper.  
9. Remove the piston base (4) or mechanic's stopper tool between the axle holder (1) and fork center bolt lock nut (3) while pushing the fork outer tube.

## NOTICE

*Be careful not to damage the lock nut and fork center bolt hole.*

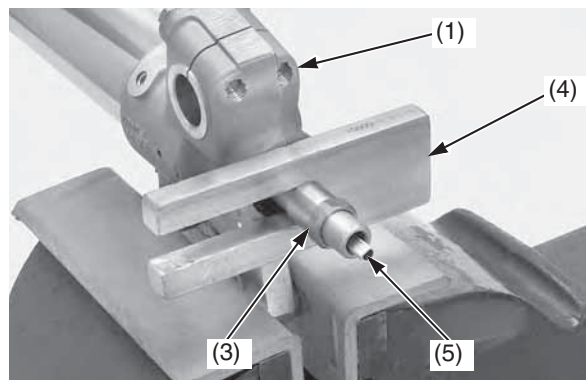

(1) axle holder (4) piston base  
(3) fork center bolt lock nut (5) push rod

10. Remove the fork damper assembly (6) from the fork assembly (7).  
Remove the fork from the vise.  
Remove the fork spring (8), spring seat collar (9) and back-up ring/seat stopper (10) from the fork damper assembly.

## NOTICE

*Do not attempt to separate the fork assembly and drop the axle holder out from the outer tube, which can damage the guide bushings (11). To avoid damage, hold both the outer tube and slider.*

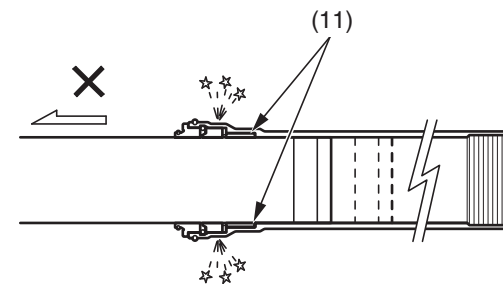

(11) guide bushing

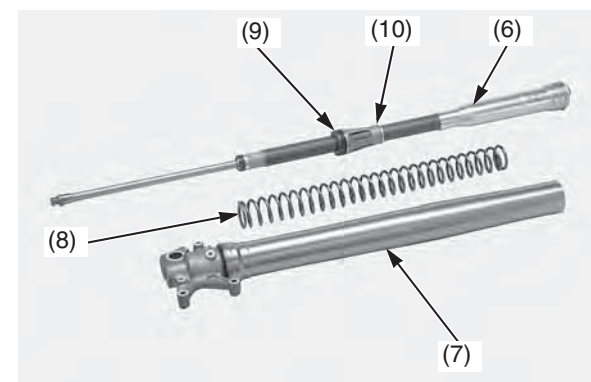

(6) fork damper assembly  
(7) fork assembly  
(8) fork spring  
(9) spring seat collar  
(10) back-up ring/seat stopper

## Damper Oil Change

1. Check the fork center bolt lock nut (1) is installed on the fork damper piston rod (2) properly.

### NOTICE

*If the lock nut was removed, the piston rod will fall into the fork damper and you will not be able to reassemble the fork damper.*

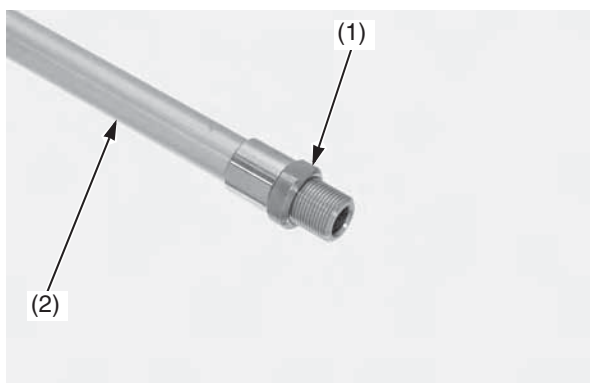

(1) fork center bolt lock nut  
(2) fork damper piston rod

2. Loosen the fork bolt assembly (3) while holding the fork damper assembly (4).

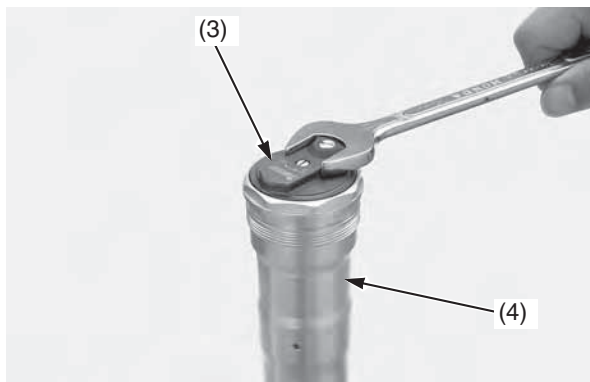

(3) fork bolt assembly (4) fork damper assembly

3. Remove the fork bolt assembly (3) from the fork damper threads and then pop it out by pumping the fork damper piston rod (2) slowly.
4. Remove the fork bolt assembly (3).

Be careful not to damage the fork bolt bushings (5). Do not disassemble the fork bolt assembly. Replace the fork bolt as an assembly if it is damaged.

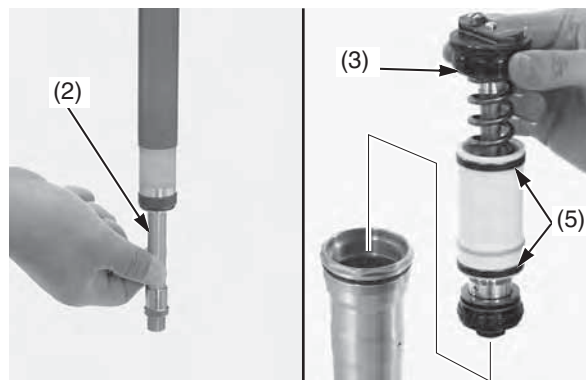

(2) fork damper piston rod (3) fork bolt assembly  
(4) fork damper assembly (5) fork bolt bushings

5. Empty the fork oil from the fork damper assembly (4) by pumping the damper rod several times.

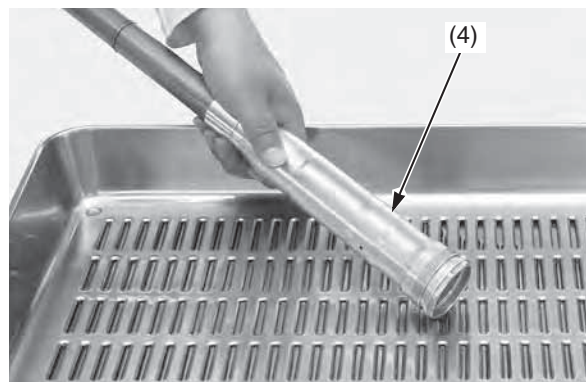

(4) fork damper assembly

6. Clean the fork bolt and fork damper assembly threads (6).

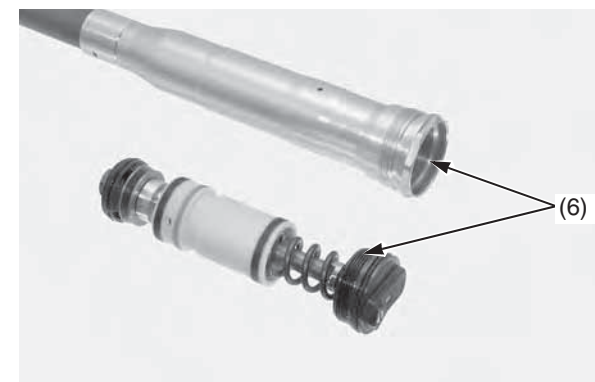

(6) fork bolt and fork damper assembly threads

7. Extend the fork damper piston rod to maximum length. Pour the recommended fork oil into the fork damper assembly (4).  
Recommended Oil:  
Pro Honda HP Fork Oil, A15-00  
Recommended Amount:  
8.4 US oz (248 cm<sup>3</sup>)

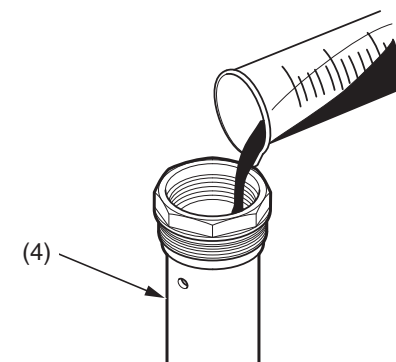

(4) fork damper assembly

(cont'd)

# Suspension

8. Pump the fork damper piston rod (2) slowly several times to bleed the air from the fork damper assembly (4).

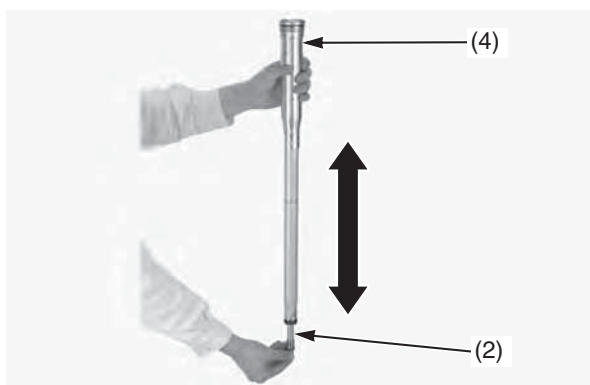

(2) fork damper piston rod  
(4) fork damper assembly

9. Apply the recommended fork oil to the fork bolt bushings (5), new O-rings (7) and new piston ring (8) on the fork bolt assembly (3).

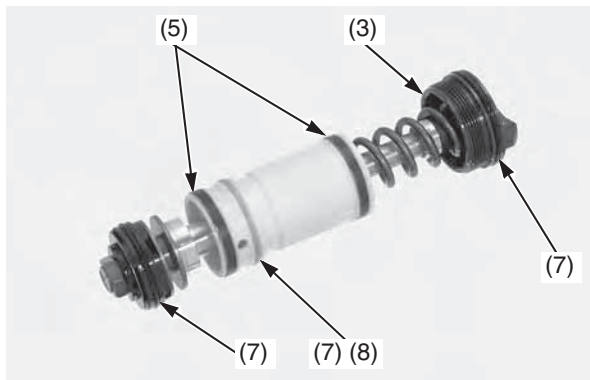

(3) fork bolt assembly  
(5) fork bolt bushings  
(7) O-rings (new)  
(8) piston ring (new)

10. Cover the oil holes (9) of the fork damper assembly with a shop towel and compress the piston rod (2) all the way. Pull the piston rod out 0.8 in (20 mm) and install the fork bolt assembly (3) into the fork damper assembly (4). Push the fork bolt assembly in slowly while pulling the piston rod out.

## NOTICE

*Be careful not to damage the fork bolt piston ring.*

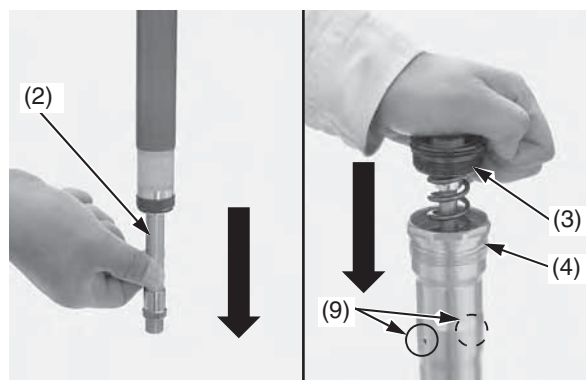

(2) fork damper piston rod  
(3) fork bolt assembly  
(4) fork damper assembly  
(9) oil holes

11. Temporarily tighten the fork bolt assembly (3) to the fork damper assembly (4).

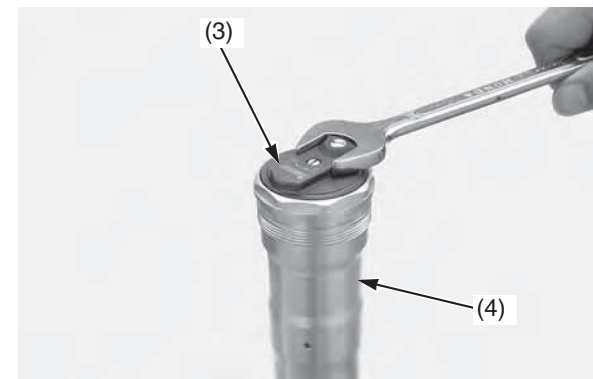

(3) fork bolt assembly  
(4) fork damper assembly

12. Completely screw in the fork center bolt lock nut (1) to the fork damper piston rod (2).

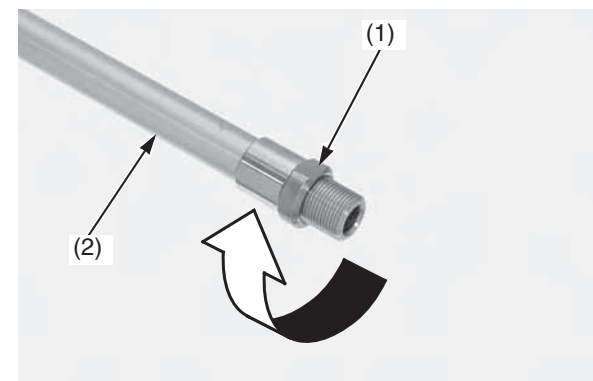

(1) fork center bolt lock nut  
(2) fork damper piston rod

13. Check the fork damper piston rod sliding surface and threads for damage.



14. Hold the fork damper assembly (4) in an upright position and pump the fork damper piston rod (2) 3.9 in (100 mm) slowly, several times.

## NOTICE

*Be careful not to bend or damage the fork damper piston rod when the piston rod is stroked.*

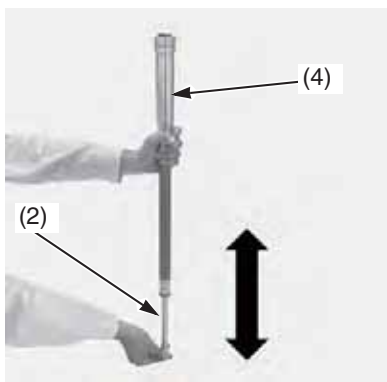

(2) fork damper piston rod (4) fork damper assembly

15. Cover the fork damper piston rod end with shop towel (10) to prevent fork damage. Cover the oil holes with shop towel to prevent blow out of fork oil. Blow the extra oil off from the fork damper assembly (4) by pumping the fork damper piston rod to full stroke.

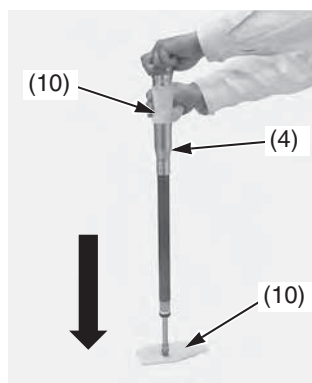

(4) fork damper assembly (10) shop towel

16. Drain the extra oil from the oil holes (9) of the fork damper assembly (4).

By doing above procedure, about 0.2 US oz (5 cm<sup>3</sup>) of fork oil will be drained from the fork damper through the oil hole and cause 8.2 US oz (243 cm<sup>3</sup>) of fork oil to be left in the fork damper assembly.

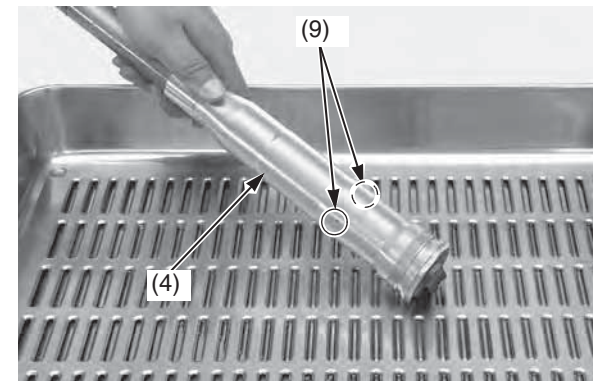

(4) fork damper assembly (9) oil holes

Pour the drained oil into a suitable container and dispose of it in an approved manner (page 164).

## NOTICE

*Improper disposal of drained fluids is harmful to the environment.*

(cont'd)



# Suspension

17. Blow out any oil from the oil hole (9) of the fork damper assembly (4) using compressed air.  
Wipe off the oil completely from the fork damper.
18. If you cannot use compressed air, remove the fork air pressure release screws (11) from the fork bolt assembly.  
Hold the fork damper upside down for 20 minutes and drain the fork oil.  
Apply the recommended fork oil to a new O-ring (12), and then install a new O-rings on the air pressure release screws (11).  
Tighten the air pressure release screws to the specified torque:  
1.0 lbf·ft (1.3 N·m, 0.1 kgf·m)

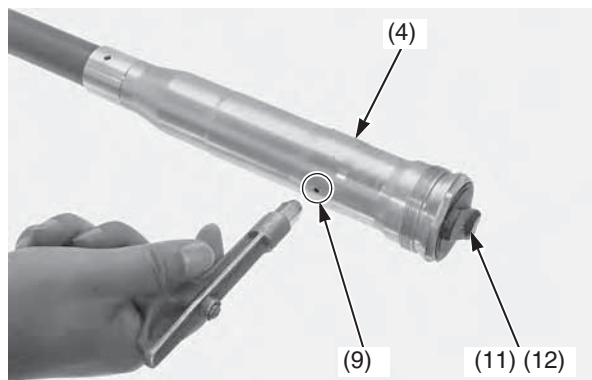

- (4) fork damper assembly
- (9) oil hole
- (11) air pressure release screws
- (12) O-rings (new)

19. Fully stroke the piston rod (2) by pushing down the fork damper assembly (4).  
Check the piston rod for smooth operation.  
If the piston rod operation is not smooth, check the piston rod for bends or damage.

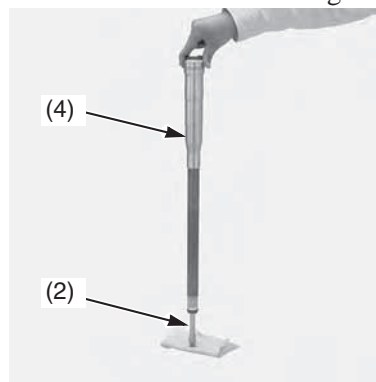

- (2) fork damper piston rod
- (4) fork damper assembly

## Fork Damper Installation

1. Drain the fork oil from the fork assembly (1) by placing it upside down.  
(About (0.2 US oz (5.4 cm<sup>3</sup>) of fork oil will be left in the fork assembly when it is left inverted for about 20 minutes at 20 °C/68 °F)

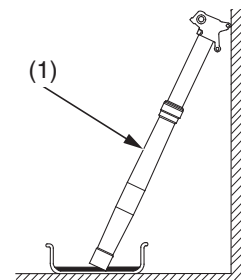

- (1) fork assembly

To properly dispose of drained fluids, refer to *You & the Environment* on page 164.

### NOTICE

*Improper disposal of drained fluids is harmful to the environment.*

Amount of fork oil left in the fork  
(without damper and spring)

unit: cm<sup>3</sup>

minute °C/°F	5	10	20	35	55	85	145
30/86	6.5	5.7	5.2	4.5	4.1	3.7	3.3
20/68	6.7	6.2	5.4	4.7	4.4	3.8	3.5
10/50	7.3	6.4	5.6	5	4.6	4.2	3.8
0/32	8.6	8.2	7.9	7.6	7.3	6.8	6

- Tighten the fork center bolt lock nut (2) fully and measure the thread length (A) as shown. Standard: 0.35 – 0.43 in (9 – 11 mm)  
Wipe the oil completely off the fork damper.

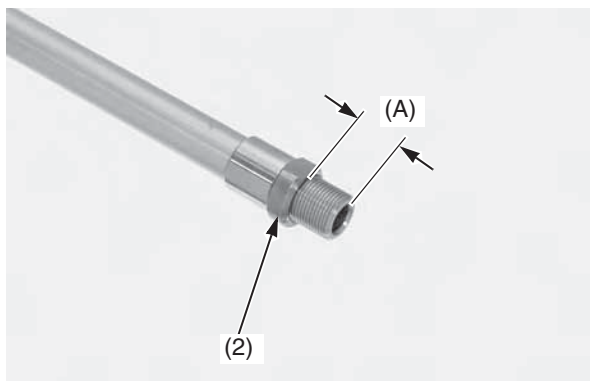

(2) fork center bolt lock nut (A) thread length

- Apply the recommended fork oil to the slider bushing (3).  
Install the seat stopper (4), back-up ring (5) and spring seat collar (6) to the fork damper (7).  
Make sure the black side of the back-up ring is seated on the seat stopper side.

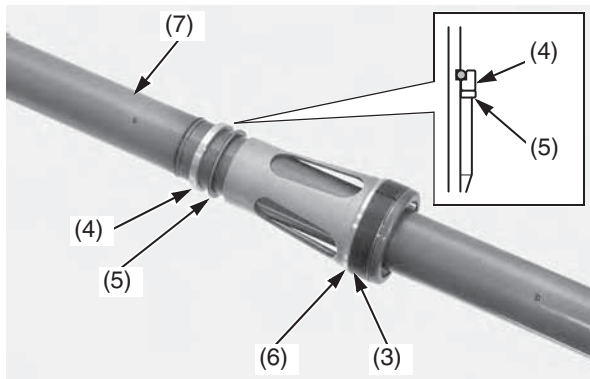

(3) slider bushing (4) seat stopper  
(5) back-up ring (6) spring seat collar  
(7) fork damper

- Blow out the oil completely off the fork spring (8).  
Put the fork spring on the fork damper assembly (9).  
Install the spring/fork damper assembly into the fork assembly (1).

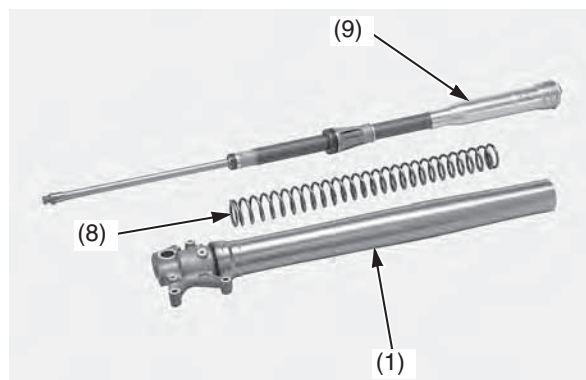

(1) fork assembly (8) fork spring  
(9) fork damper assembly

- Temporarily tighten the fork damper assembly (9) to the outer tube (10) using the lock nut wrench (11).

- Lock nut wrench 07WMA-KZ30100

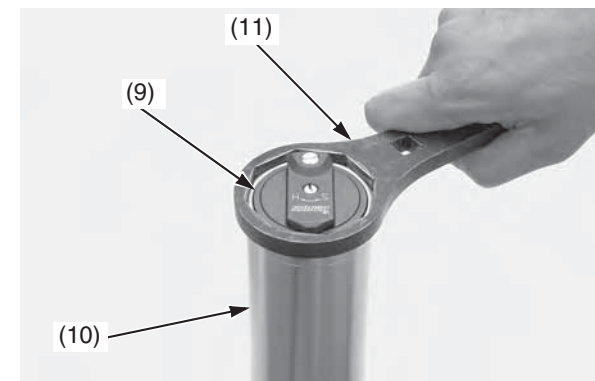

(9) fork damper assembly (11) lock nut wrench  
(10) outer tube

- Place the lower end (axle holder) (12) of the slider in a vise with a piece of wood or soft jaws to avoid to damage.

## NOTICE

*Over-tightening the vise can damage the axle holder.*

(cont'd)

# Suspension

7. Push the outer tube until the fork center bolt lock nut (2) is fully exposed and install the piston base (13) or mechanic's stopper tool between the axle holder (12) and fork center bolt lock nut.
- Measure the thread length again.  
Standard: 0.35 – 0.43 in (9 – 11 mm)
- Piston base 07958-2500001

8. Install the push rod (14) into the piston rod (15) until it stops.

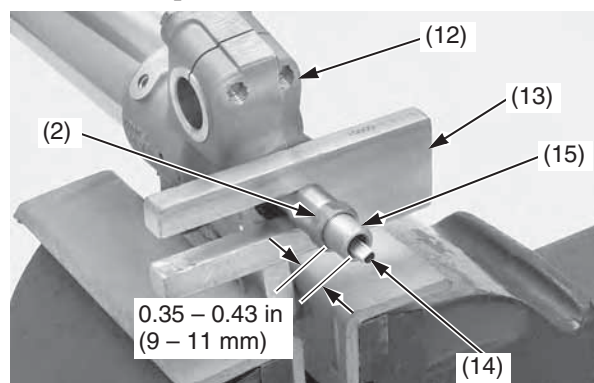

(2) fork center bolt lock nut  
(12) axle holder  
(13) piston base  
(14) push rod  
(15) piston rod

9. Apply fork oil to new O-ring (16) and install it to the fork center bolt (17). Install the fork center bolt to the fork damper piston rod (15) by aligning the each flat-side of the fork center bolt adjusting rod and the push rod (14).  
Tighten the fork center bolt fully by hand.

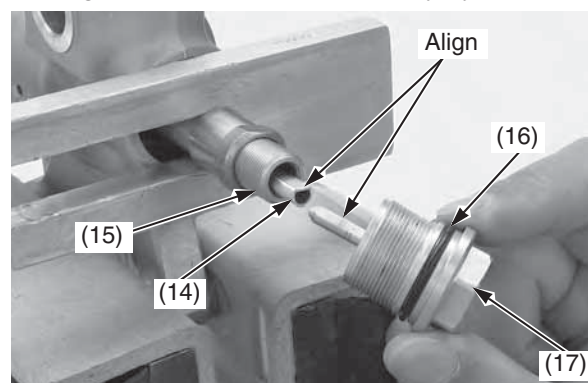

(14) push rod  
(15) piston rod  
(16) O-ring (new)  
(17) fork center bolt

10. Measure the clearance between the fork center bolt lock nut (2) and fork center bolt (17).  
Standard: 0.06 – 0.08 in (1.5 – 2.0 mm)

If the clearance is out of specification, check the fork center bolt lock nut and fork center bolt installation.

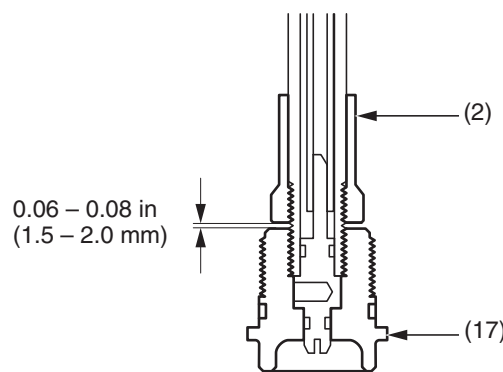

(2) fork center bolt lock nut (17) fork center bolt

11. Tighten the fork center bolt lock nut (2) to the fork center bolt (17) closely by hand. Tighten the fork center bolt lock nut to the specified torque:  
21 lbf-ft (28 N·m, 2.9 kgf·m)

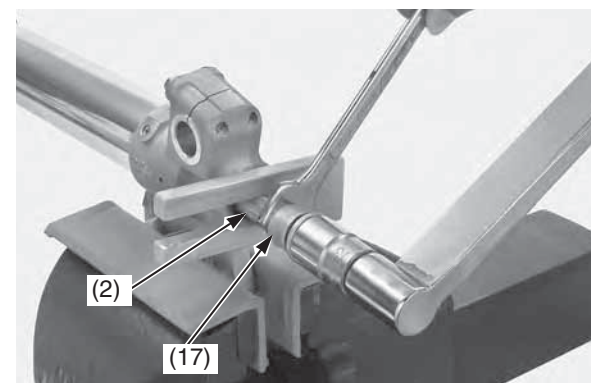

(2) fork center bolt lock nut  
(17) fork center bolt

12. Apply locking agent to the fork center bolt threads.  
Remove the piston base or mechanic's stopper tool while pushing the outer tube.  
Install the fork center bolt (17) to the axle holder and tighten it to the specified torque:  
51 lbf-ft (69 N·m, 7.0 kgf·m)

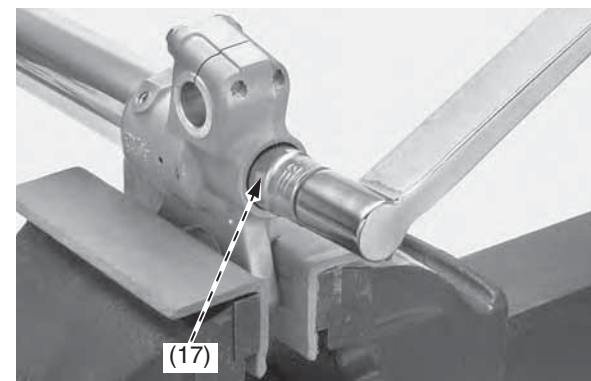

(17) fork center bolt

13. Remove the fork from the vice.
14. Measure the length between the axle holder and outer tube.  
Standard:  $12.3 \pm 0.1$  in ( $312 \pm 2$  mm)
15. Compare the length (18) at assembly and at disassembly. They should be the same length.

If the length at assembly is longer than at disassembly, check the fork center bolt and fork center bolt lock nut installation.

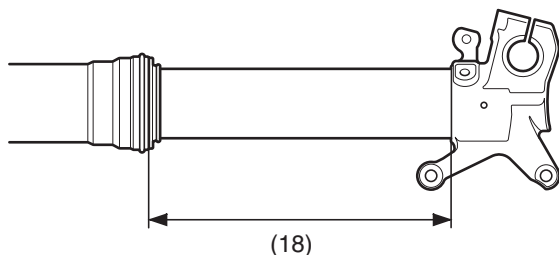

(18) length

16. Refilling the fork oil (page 101).
17. Install the front suspension (page 102).

## Rear Suspension Inspection

The swingarm is controlled by one hydraulic shock absorber with an aluminum reservoir for oil and nitrogen gas pressure. The gas pressure in the reservoir is contained within a rubber bladder.

The rear suspension's spring pre-load and damping adjustments (compression and rebound) should be adjusted for the rider's weight and track conditions (pages 149, 151, 154).

Do not attempt to disassemble, service, or dispose of the damper; see your dealer.

The instructions found in this owner's manual are limited to adjustments of the shock assembly only.

- When your CRF is new, break it in for approximately 1 hour with the standard suspension settings before attempting to adjust the rear suspension.
- Refer to *Suspension Adjustment Guidelines* (page 154) for making all rebound and compression damping adjustments in one click or 1/12 turn increments. (Adjusting two or more clicks or turns at a time may cause you to pass over the best adjustment.) Test ride after each adjustment.
- If the rear suspension is too stiff/soft, adjust it by turning all the compression and rebound adjusters according to the procedures described in page 154. After adjusting the adjusters simultaneously, suspension may be fine-tuned by turning one of the compression and rebound damping adjusters in one click or in 1/12 turn increments.
- If you have a problem finding an acceptable adjustment, return to the standard position and begin again.

1. Bounce the rear of the motorcycle up and down and check for smooth suspension action.

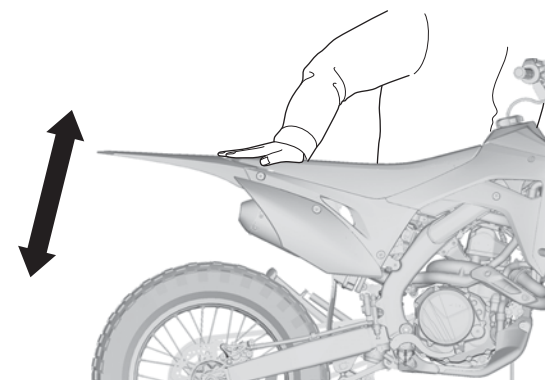

2. Remove the right and left mufflers (page 126), and subframe (page 39).
3. Check for a broken or collapsed spring.
4. Check the rear shock absorber (1) for a bent rod or oil leaks.

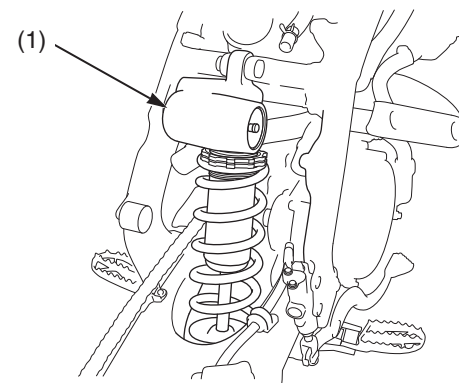

(1) rear shock absorber

5. Push the rear wheel sideways to check for worn or loose swingarm bearings. There should be no movement. If there is, have the bearings replaced by your dealer.

# Brakes

Refer to *Important Safety Precautions* on page 23.

Both the front and rear brakes are the hydraulic disc type. As the brake pads wear, the brake fluid level will drop. A leak in the system will also cause the level to drop.

Frequently inspect the system to ensure there are no fluid leaks. Periodically inspect the brake fluid level and the brake pads for wear.

If the braking response of the front brake lever or rear brake pedal feels unusual, check the brake pads. If the brake pads are not worn beyond the recommended limit (page 117), there is probably air in the brake system.

Refer to an official Honda Service Manual or see your dealer to have the air bled from the system.

## Front Brake Lever Adjustment

1. Slide the front brake lever cover (1).

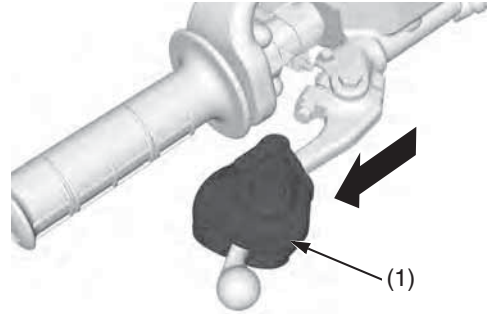

- (1) brake lever cover
2. Loosen the lock nut (2).
3. To position the front brake lever farther away from the handgrip, turn the adjuster (3) clockwise.  
To position the front brake lever closer to the handgrip, turn the adjuster counterclockwise.
4. While holding the adjuster, tighten the lock nut to the specified torque:  
4.4 lbf·ft (5.9 N·m, 0.6 kgf·m)
5. Apply silicone grease to the contacting areas of the adjuster and knocker arm (4).

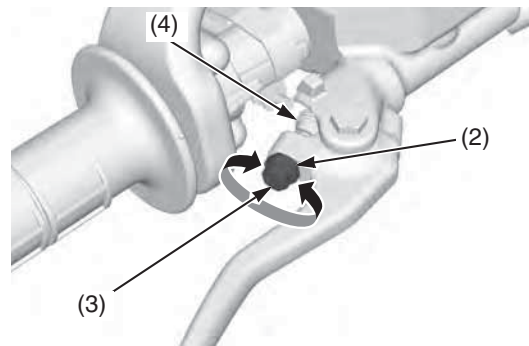

- (2) lock nut
- (3) adjuster
- (4) knocker arm
6. Install the front brake lever cover in the reverse order.

## Rear Brake Pedal Height

The rear brake pedal height should be approximately level with the right footpeg.

1. Loosen the lock nut (1) and turn the push rod (2) in direction (+) to raise the rear brake pedal (3) or in direction (–) to lower it.
2. Tighten the push rod lock nut to the specified torque at the desired pedal height.  
4.4 lbf·ft (5.9 N·m, 0.6 kgf·m)

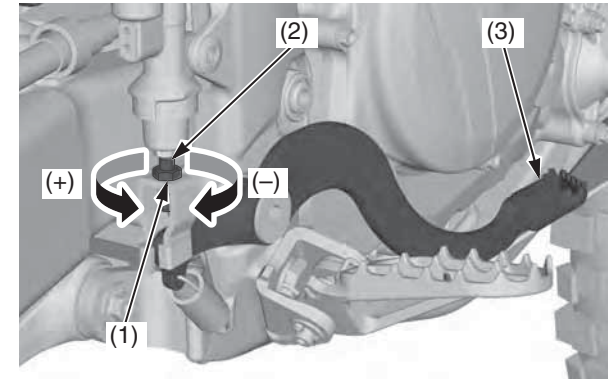

- (1) lock nut
- (2) push rod
- (3) rear brake pedal
- (+) raise the pedal height
- (–) lower the pedal height



## Fluid Level Inspection

### Front Brake Fluid Level Check

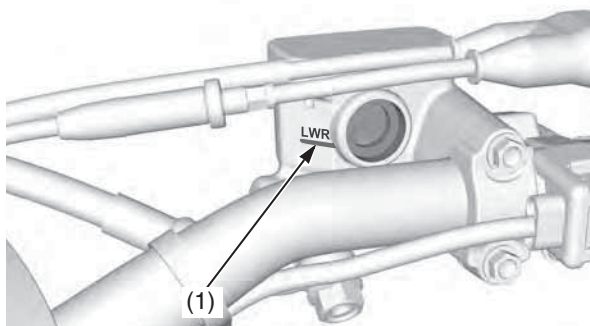

(1) LWR mark

With the motorcycle in an upright position, check the fluid level.

It should be above the LWR mark (1). If the level is at or below the LWR mark, check the brake pads for wear (page 117).

Worn brake pads should be replaced. If the pads are not worn, have your brake system inspected for leaks.

If the pulling distance for the front brake lever feels excessive, there is probably air in the brake system and it must be bled. Refer to an official Honda Service Manual or see your dealer for brake bleeding.

Honda recommends using Honda DOT 4 Brake Fluid from a sealed container, or an equivalent.

#### Other Checks:

Make sure there are no fluid leaks. Check for deterioration or cracks in the hoses and fittings.

### Rear Brake Fluid Level Check

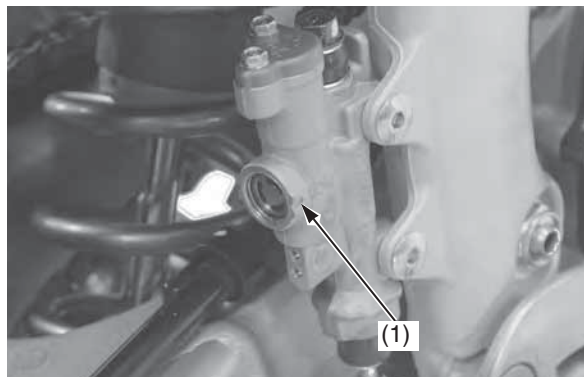

(1) LOWER mark

With the motorcycle in an upright position, check the fluid level.

It should be above the LOWER mark (1). If the level is at or below the LOWER mark, check the brake pads for wear (page 117).

Worn brake pads should be replaced. If the pads are not worn, have your brake system inspected for leaks.

If the travel for the rear brake pedal feels excessive, there is probably air in the brake system and it must be bled. Refer to an official Honda Service Manual or see your dealer for brake bleeding.

Honda recommends using Honda DOT 4 Brake Fluid from a sealed container, or an equivalent.

#### Other Checks:

Make sure there are no fluid leaks. Check for deterioration or cracks in the hoses and fittings.

# Brakes

## Adding Front Brake Fluid

### NOTICE

Spilled brake fluid will severely damage painted surfaces. It is also harmful to some rubber parts. Be careful whenever you remove the reservoir cap; make sure the reservoir is horizontal first.

- Always use fresh DOT 4 brake fluid from a sealed container when servicing the system. Do not mix different types of fluid, they may not be compatible.
  - The recommended brake fluid is Honda DOT 4 Brake Fluid or an equivalent.
1. Remove the front brake reservoir cap screws (1), reservoir cap (2) and diaphragm (3).
  2. Fill the reservoir with DOT 4 brake fluid to the upper level mark (4). Do not overfill.
  3. Install the diaphragm and reservoir cap.
  4. Tighten the front brake reservoir cap screws to the specified torque:  
0.7 lbf·ft (1.0 N·m, 0.1 kgf·m)

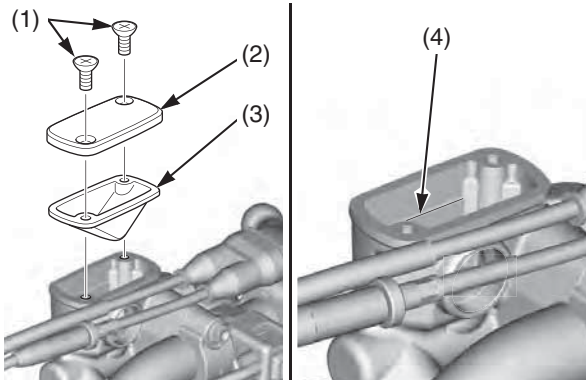

- (1) front brake reservoir cap screws
- (2) reservoir cap
- (3) diaphragm
- (4) upper level mark

## Adding Rear Brake Fluid

### NOTICE

Spilled brake fluid will severely damage painted surfaces. It is also harmful to some rubber parts. Be careful whenever you remove the reservoir cap; make sure the reservoir is horizontal first.

- Always use fresh DOT 4 brake fluid from a sealed container when servicing the system. Do not mix different types of fluid, they may not be compatible.
  - The recommended brake fluid is Honda DOT 4 Brake Fluid or an equivalent.
1. Remove the rear brake reservoir cap bolts (1), reservoir cap (2), set plate (3) and diaphragm (4).
  2. Fill the reservoir with DOT 4 brake fluid to the upper level mark (5). Do not overfill.

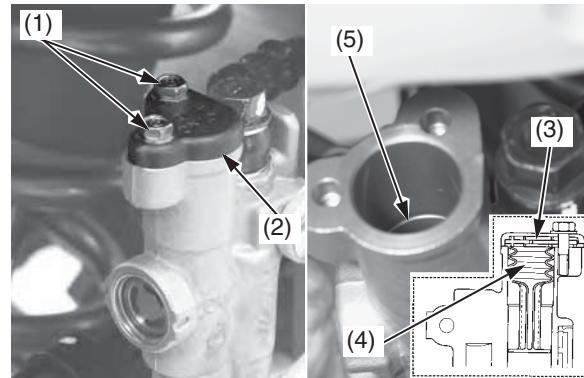

- (1) rear brake reservoir cap bolts
- (2) reservoir cap
- (3) set plate
- (4) diaphragm
- (5) upper level mark

3. Install the diaphragm, set plate and reservoir cap.
4. Tighten the rear brake reservoir cap bolts to the specified torque:  
0.7 lbf·ft (1.0 N·m, 0.1 kgf·m)

## Brake Pad Wear

Brake pad wear depends on the severity of usage and track conditions. (Generally, the pads will wear faster with wet and dirty track conditions.) Inspect the brake pads at each regular maintenance interval (pages 25, 26).

### Front Brake Pads

Inspect the brake pads (1) through the front wheel to determine the brake pad wear. If either brake pad is worn anywhere to a thickness of 0.04 in (1.0 mm), both brake pads must be replaced.

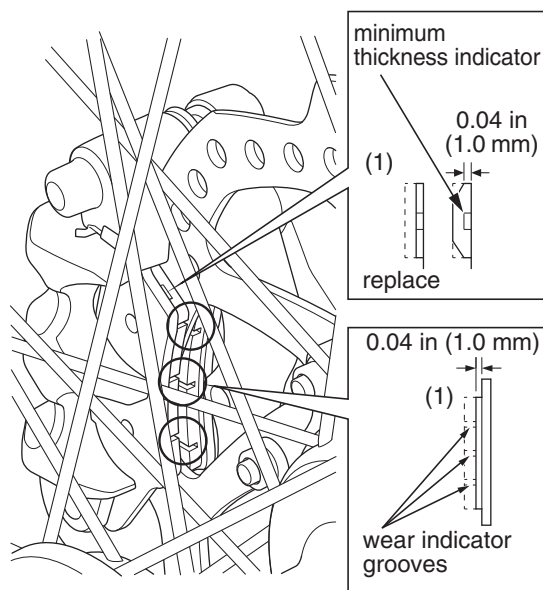

(1) brake pads

### Rear Brake Pads

Inspect the brake pads (1) from the rear side of the caliper (2) to determine the brake pad wear. If either brake pad is worn anywhere to a thickness of 0.04 in (1.0 mm), both brake pads must be replaced.

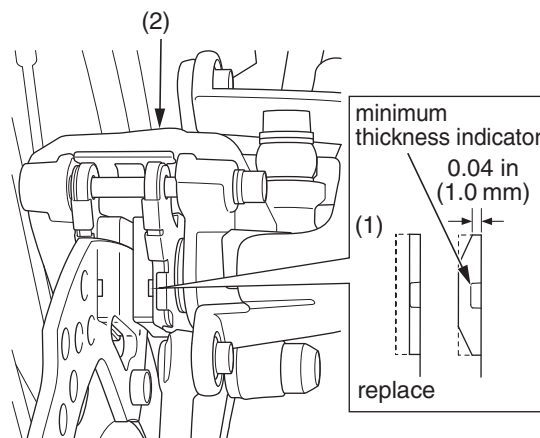

(1) brake pads  
(2) rear brake caliper

## Other Inspections

Check that the front brake lever and rear brake pedal assemblies are positioned properly (page 114) and the securing bolts are tight.

Make sure there are no fluid leaks. Check for deterioration or cracks in the hoses and fittings.

# Wheels

Refer to *Important Safety Precautions* on page 23.

Keeping the wheels true (round) and maintaining correct spoke tension are critical to safe motorcycle operation. During the first few rides, spokes will loosen more rapidly due to the initial seating of the parts. Excessively loose spokes may result in instability at high speeds and the possible loss of control. It's also important that the rim locks are secure to prevent tire slippage.

## Wheel Rims & Spokes

1. Inspect the wheel rims (1) and spokes (2) for damage.
2. Tighten, any loose spokes and rim locks (3) to the specified torque:  
Spokes: 2.7 lbf·ft (3.7 N·m, 0.4 kgf·m)  
Rim Locks: 9 lbf·ft (12 N·m, 1.2 kgf·m)
3. Check wheel rim runout. If runout is noticeable, see an official Honda Service Manual for inspection instructions.

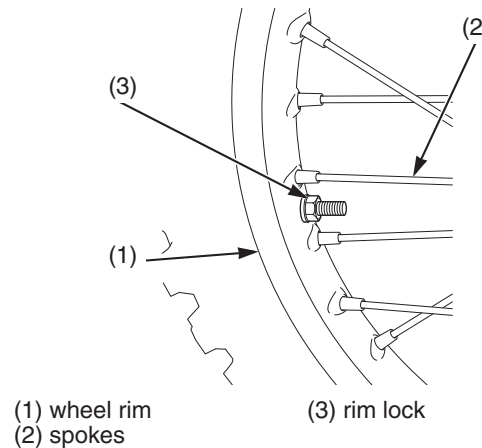

## Axles & Wheel Bearings

See an official Honda Service Manual for inspection information:

1. Check the axle shaft for runout.
2. Check the condition of the wheel bearings.

Refer to *Important Safety Precautions* on page 23.

To safely operate your CRF, the tires must be the proper type (off-road) and size, in good condition with adequate tread, and correctly inflated.

## WARNING

Using tires that are excessively worn or improperly inflated can cause a crash in which you can be seriously hurt or killed.

Follow all instructions in this owner's manual regarding tire inflation and maintenance.

The following pages give detailed information on how and when to check your air pressure, how to inspect your tires for wear and damage, and our recommendations on tire repair and replacement.

## Air Pressure

Properly inflated tires provide the best combination of handling, tread life, and riding comfort. Generally, underinflated tires wear unevenly, adversely affect handling, and are more likely to fail from being overheated. Underinflated tires can also cause wheel damage on hard terrain. Overinflated tires make your CRF ride harshly, are more prone to damage from surface hazards, and wear unevenly.

Make sure the valve stem caps are secure. If necessary, install new caps.

Always check air pressure when your tires are “cold.” If you check air pressure when your tires are “warm” — even if your CRF has only been ridden for a few miles — the readings will be higher. If you let air out of warm tires to match the recommended cold pressures, the tires will be underinflated.

The correct “cold” tire pressures are:

Front	15 psi (100 kPa, 1.0 kgf/cm <sup>2</sup> )
Rear	15 psi (100 kPa, 1.0 kgf/cm <sup>2</sup> )

If you decide to adjust tire pressures for a particular riding condition, make changes a little at a time.

## Inspection

Take time to inspect your tires and wheels before you ride.

- Inspect carefully for bumps or bulges in the side of the tire or the tread. Replace any tire that has a bump or bulge.
- Look closely for cuts, slits, or cracks in the tires. Replace a tire if you can see fabric or cord.
- Check for rocks or other objects embedded in the tire or tread. Remove any objects.
- Check the position of both valve stems. A tilted valve stem indicates the tube is slipping inside the tire or the tire is slipping on the rim.

## Tube Replacement

If a tube is punctured or damaged, you should replace it as soon as possible. A repaired tube may not have the same reliability as a new one, and it may fail while you are riding.

Use a replacement tube equivalent to the original.



# Tires & Tubes

## Tire Replacement

The tires that came on your CRF were designed to provide a good combination of handling, braking, durability, and comfort across a broad range of riding conditions.

### **WARNING**

Installing improper tires on your motorcycle can affect handling and stability. This can cause a crash in which you can be seriously hurt or killed.

Always use the size and type of tires recommended in this owner's manual.

(CRF450RX)

Front	90/90-21 54M	
	DUNLOP	AT81F
Rear	120/90-18 65M	
	DUNLOP	AT81
Type	bias-ply, tube	

(CRF450R/RWE)

Front	80/100-21 51M	
	DUNLOP	MX3SF
Rear	120/80-19 63M	
	DUNLOP	MX3S
Type	bias-ply, tube	

- When replacing, use the original equipment tires or equivalent tires of the same size, construction, speed rating, and load range as the original.
- Replace the tube any time you replace a tire. The old tube will probably be stretched and, if installed in a new tire, could fail.

Refer to *Important Safety Precautions* on page 23.

1. Check the side stand spring (1) for damage and loss of tension.
2. Check the side stand assembly for freedom of movement.

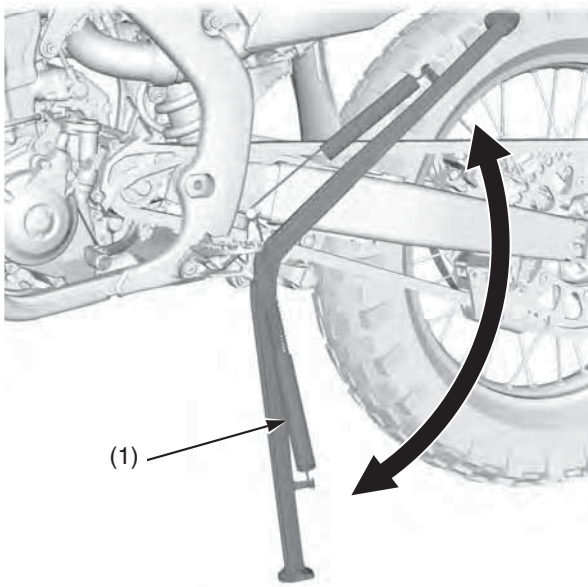

(1) side stand spring

If the side stand is stiff or squeaky, clean the pivot area and lubricate the pivot bolt with molybdenum grease.

# Drive Chain

Refer to *Important Safety Precautions* on page 23.

The service life of the chain depends on proper lubrication and adjustment. Poor maintenance can cause premature wear or damage to the drive chain or sprockets.

When the motorcycle is ridden on unusually dusty or muddy tracks, more frequent maintenance will be necessary.

Before servicing your drive chain, turn the engine OFF and check that your transmission is in neutral.

## Inspection

1. Turn the engine off, raise the rear wheel off the ground by placing an optional workstand or equivalent support under the engine and shift the transmission into neutral.
2. Check the drive chain slack (1) in the upper drive chain run midway between the drive sprocket (2) and driven sprocket (3). Drive chain slack should allow the following vertical movement by hand:  
1 3/8 – 1 3/4 in (35 – 45 mm)

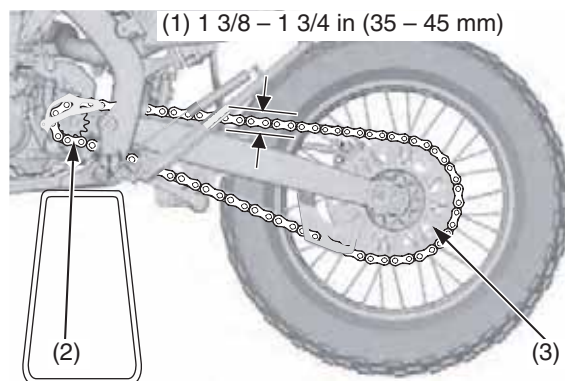

(1) drive chain slack (3) driven sprocket  
(2) drive sprocket

3. Check drive chain slack at several points along the chain. The slack should remain constant. If it isn't, some links may be kinked and binding. Lubricating the chain will often eliminate binding and kinking.

## NOTICE

*Excessive chain slack may allow the drive chain to damage the engine cases.*

4. Inspect the drive chain for:
  - damaged rollers
  - loose pins
  - dry or rusted links
  - kinked or binding links
  - excessive wear

Replace the drive chain (page 124) if it has damaged rollers, loose pins, or kinks that cannot be free. Lubricate the drive chain (page 123) if it appears dry or shows signs of rust. Lubricate any kinked or binding links and work them free. Adjust chain slack if needed (page 123).

## Drive Chain Sliders

1. Check the chain slider (1) for wear. Replace it if below the service limit.  
**SERVICE LIMIT:**  
upper side: 0.2 in (5 mm)  
lower side: 0.10 in (2.5 mm)

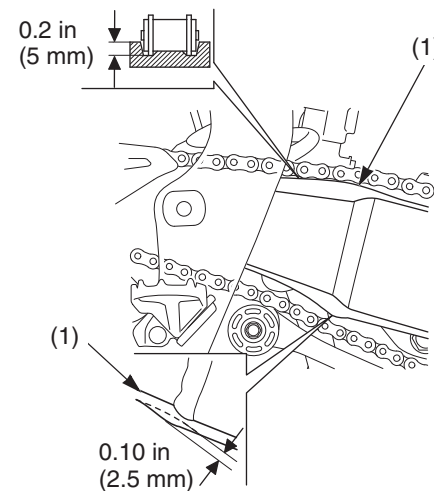

(1) chain slider

2. Check the chain guide slider (2) for wear. Replace the guide slider if it is worn to the bottom of the wear limit (3).

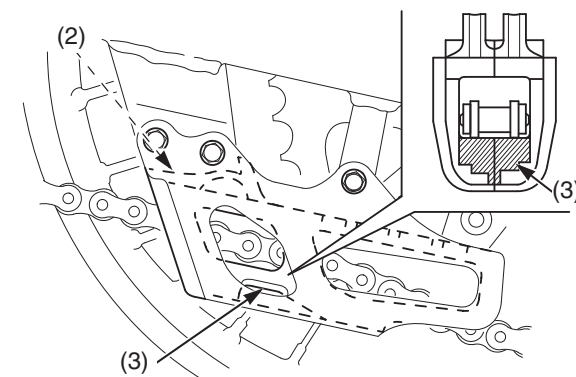

(2) chain guide slider (3) wear limit

## Drive Chain Rollers

Check the upper drive chain roller (1) and lower drive chain roller (2) for wear or damage. Measure the diameter of the drive chain rollers and replace them if below the service limit.

Service Limit:

Upper roller: 1.2 in (31 mm)

Lower roller: 1.2 in (31 mm)

Replace the roller if necessary as follows.

Install the upper drive chain roller (Green) with the “→” mark (3) facing toward the bracket and lower drive chain roller (Black) with the “→” mark facing toward outside.

Clean the threads of the lower drive chain roller bolt and apply locking agent to the threads.

Install new a drive chain roller bolt (4) and nut (5).

Tighten the drive chain roller bolt and nut to the specified torque:

9 lbf·ft (12 N·m, 1.2 kgf·m)

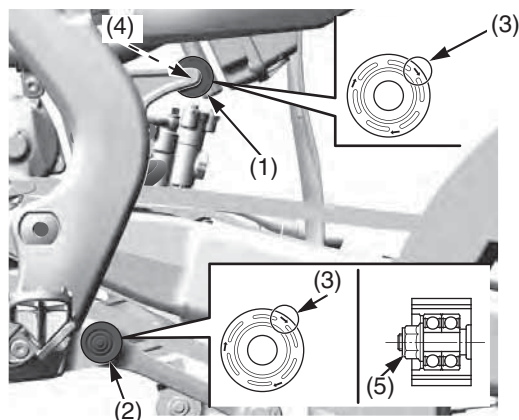

- (1) upper drive chain roller (Green)
- (2) lower drive chain roller (Black)
- (3) “→” mark
- (4) drive chain roller bolt (new)
- (5) drive chain roller nut

## Adjustment

1. Loosen the rear axle nut (1).
2. Loosen the chain adjuster lock nuts (2) and turn the adjusting bolts (3) counterclockwise to decrease slack or clockwise to increase slack. Align the index marks (4) of the axle plates (5) with the same reference marks (6) on both sides of the swingarm.

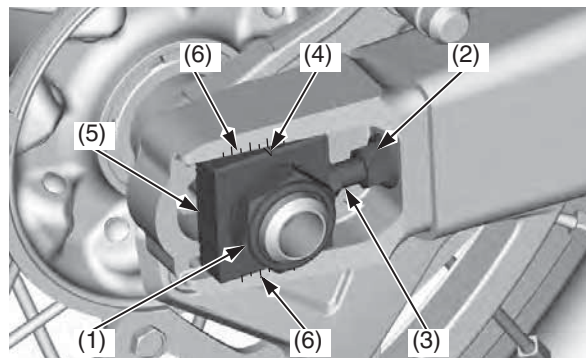

- (1) rear axle nut
- (2) chain adjuster lock nuts
- (3) adjusting bolts
- (4) index marks
- (5) axle plates
- (6) reference marks

3. Tighten the rear axle nut to the specified torque:  
94 lbf·ft (128 N·m, 13.1 kgf·m)
4. Recheck chain slack and adjust as necessary.
5. Turn the adjusting bolt counterclockwise until it touches the axle plates lightly. Then tighten the chain adjuster lock nuts to the specified torque while holding the adjusting bolts with a wrench:  
20 lbf·ft (27 N·m, 2.8 kgf·m)

## Lubrication

(CRF450RX)

Lubricate the drive chain with Pro Honda HP Chain Lube or an equivalent chain lubricant or drive chain lubricant designed specifically for use with O-ring chains. Wipe off the excess chain lubricant.

Commercial chain lubricants not designed for motorcycle drive chains may contain solvents which could damage the O-rings.

(CRF450R/RWE)

Commercially prepared drive chain lubricants may be purchased at most motorcycle shops and should be used in preference to motor oil. Pro Honda HP Chain Lube or an equivalent is recommended.

Saturate each chain joint so that the lubricant penetrates the space between adjacent surfaces of the link plates and rollers.

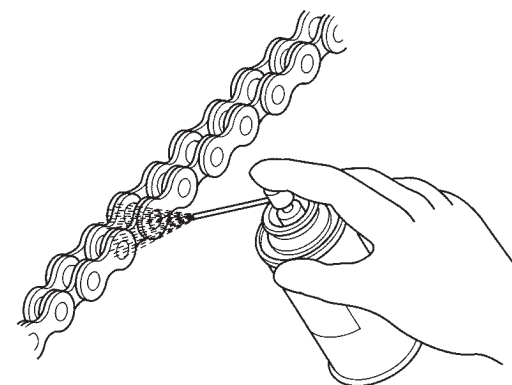

# Drive Chain

## Removal, Cleaning & Replacement (CRF450RX)

For maximum service life, the drive chain should be cleaned, lubricated, and adjusted before each outing. Your CRF has an endless (riveted master link) type chain. It should only be removed or replaced by your dealer.

The O-rings can be damaged by steam cleaning, high pressure washers, and certain solvents.

1. Clean the side surfaces of the chain with a dry cloth. Use a high flash point solvent such as kerosene or Pro Honda chain cleaner – not gasoline. Do not brush the rubber O-rings. Brushing will damage them. Use of a solvent may also damage the O-rings.
2. Replace the drive chain if it has damaged rollers, loose fitting links, damaged O-rings, or otherwise appears unserviceable.
3. Measure the drive chain plate (1). If the height of any of the drive chain plates is less than 0.52 inch (13.3 mm), the drive chain must be replaced.

Chain:

Size/link: RK520EXU/114LE

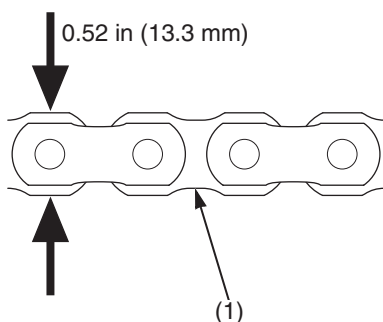

(1) drive chain plate (inner)

4. Inspect the sprocket teeth for wear or damage. We recommend replacing the sprocket whenever a new chain is installed. Both chain and sprockets must be in good condition, or the new replacement chain or sprocket(s) will wear rapidly. Excessively worn sprocket teeth have a hooked, worn appearance. Replace any sprocket which is damaged or excessively worn.

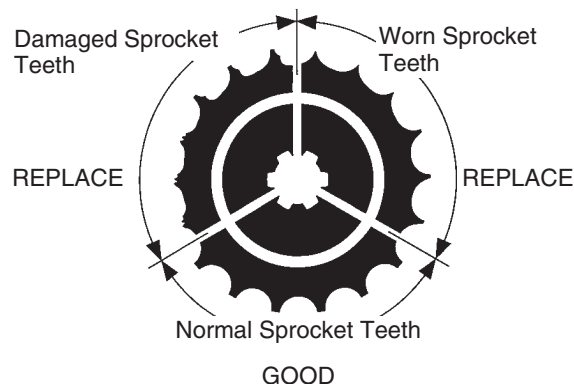

### NOTICE

*Use of a new chain with worn sprockets will cause rapid chain wear.*

5. Lubricate the drive chain (page 123).
6. Recheck chain slack and adjust if necessary.

## Removal, Cleaning & Replacement (CRF450R/RWE)

For maximum service life, the drive chain should be cleaned, lubricated, and adjusted before each outing.

1. Remove the master link retaining clip (1) with pliers.

Do not bend or twist the clip.

2. Remove the master link (2) and link plate (3). Remove the drive chain.

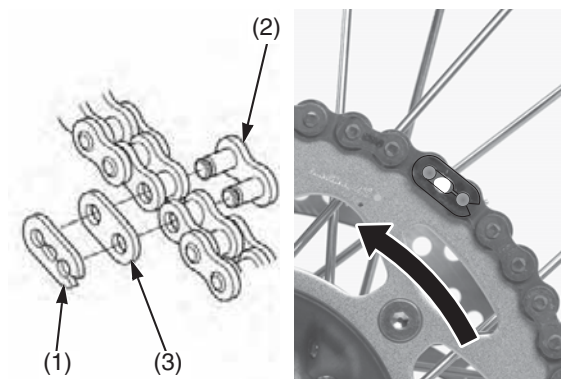

(1) master link retaining clip (2) master link (3) link plate

3. Clean the drive chain in high flash-point solvent and allow it to dry.



- Inspect the drive chain for possible wear or damage. Replace the drive chain if it has damaged rollers, loose fitting links, or otherwise appears unserviceable.
- Measure the drive chain plate (4). If the height of any of the drive chain plates is less than 0.55 inch (14.0 mm), the drive chain must be replaced.

Chain:  
Size/link:  
RK520TXZ/114RJ (CRF450R)  
GB520TXZ/114RJ (CRF450RWE)

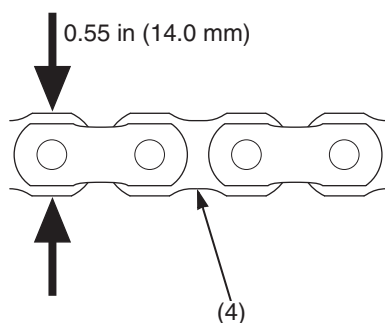

(4) drive chain plate (inner)

- Inspect the sprocket teeth for wear or damage. We recommend replacing the sprocket whenever a new chain is installed. Both chain and sprockets must be in good condition, or the new replacement chain or sprocket(s) will wear rapidly. Excessively worn sprocket teeth have a hooked, worn appearance. Replace any sprocket which is damaged or excessively worn.

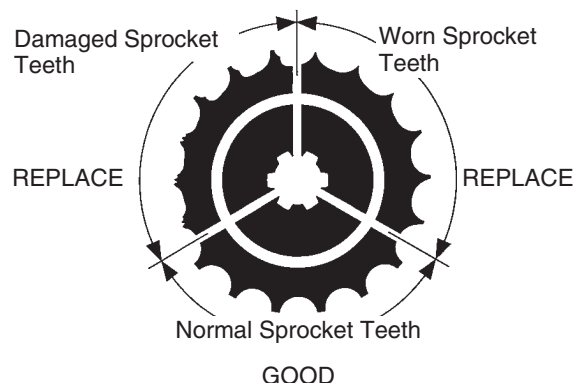

### NOTICE

*Use of a new chain with worn sprockets will cause rapid chain wear.*

- Install the chain.
- Measure a section of the drive chain to determine whether the chain is worn beyond its service limit. Put the transmission in gear, and then turn the rear wheel forward until the lower section of the chain is pulled taut. With the chain held taut and any kinked joints straightened, measure the distance between a span of 17 pins, from pin center to pin center.

If the measurement exceeds the service limit, replace the chain. After the chain is measured, shift the transmission into neutral again before proceeding with inspection and service.

Service limit: 10.12 in (257.0 mm)

MEASURE A SPAN OF 17 PINS (16 PITCHES)

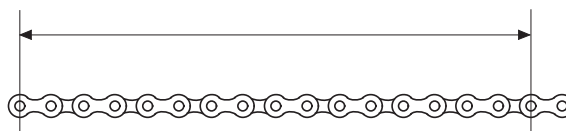

- Lubricate the drive chain (page 123).
- Pass the chain over the sprockets and join the ends of the chain with the master link. For ease of assembly, hold the chain ends against adjacent driven sprocket teeth while inserting the master link. Install the master link retaining clip so that the closed end of the clip will face the direction of forward wheel rotation.
- Recheck chain slack and adjust as necessary.

### More About Drive Chain (CRF450R/RWE)

- The master link is the most critical element of drive chain security. Master links are reusable, as long as they remain in excellent condition. We recommend installing a new master link retaining clip when the drive chain is reassembled.
- You may find it easier to install a new chain by connecting it to the old chain with a master link and pulling the old chain to position the new chain on the sprockets.

# Exhaust Pipe/Muffler

Refer to *Important Safety Precautions* on page 23.

## Exhaust Pipe/Muffler Inspection

Check the mounting bolts and exhaust pipe joint nuts for tightness.

Check the exhaust pipe and mufflers for cracks or deformation.

A damaged exhaust pipe and mufflers may reduce engine performance.

## Muffler Removal

(CRF450R/RX)

1. Remove the seat (page 34).
2. Remove the side covers (1) and air cleaner housing covers (2) by removing the bolts (3).

The procedure is the same for the both right and left side.

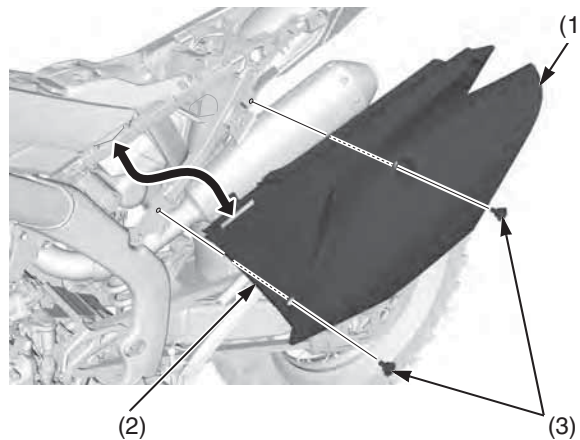

- (1) side covers (3) bolts  
(2) air cleaner housing covers

3. Loosen the right muffler clamp bolt (4).

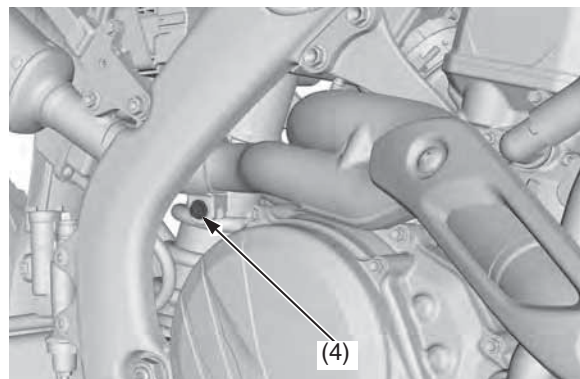

- (4) right muffler clamp bolt

4. Remove the right muffler mounting A bolt (5), B bolt (6), washer (7), and right muffler (8).

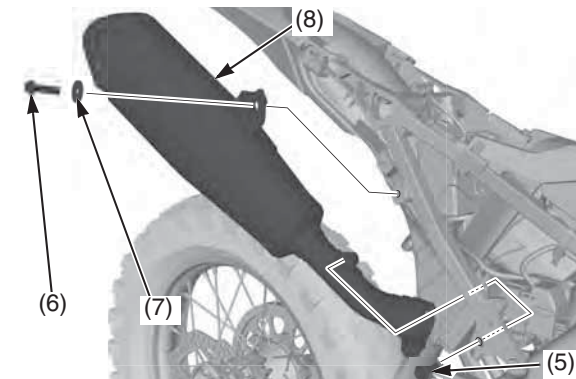

- (5) right muffler mounting A bolt  
(6) right muffler mounting B bolt  
(7) washer  
(8) right muffler

- Loosen the left muffler clamp bolt (9).

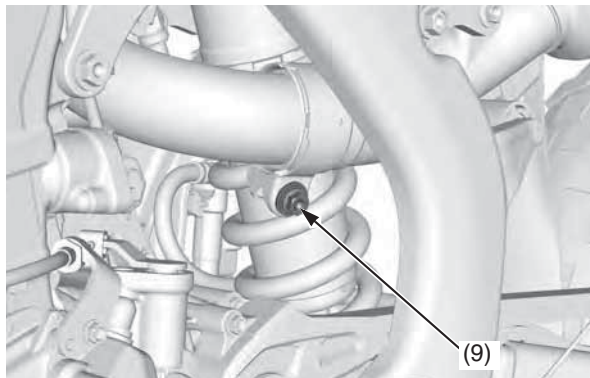

(9) left muffler clamp bolt

- Remove the left muffler mounting A bolt (10), B bolt (11), washer (12) and left muffler (13).

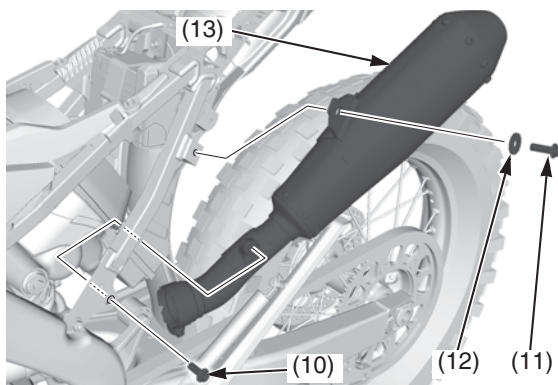

(10) left muffler mounting A bolt  
 (11) left muffler mounting B bolt  
 (12) washer  
 (13) left muffler

(CRF450RWE)

- Remove the seat (page 34).
- Remove the side covers and air cleaner housing covers (page 126).
- Remove the right muffler mounting B bolt (1), washer (2) and right muffler (3).

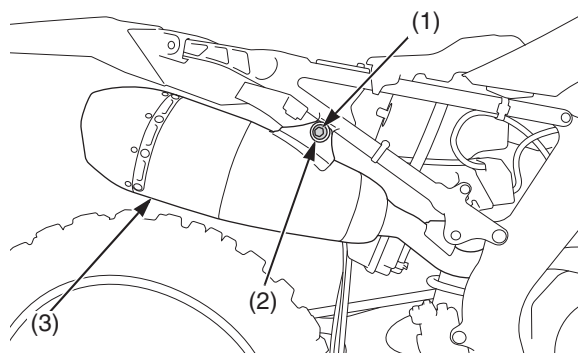

(1) right muffler mounting B bolt  
 (2) washer  
 (3) right muffler

- Remove the left muffler mounting B bolt (4), washer (5) and left muffler (6).

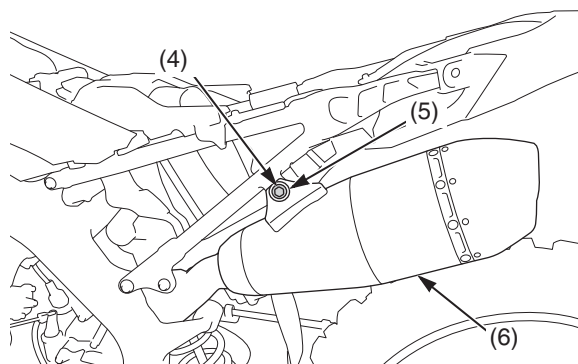

(4) left muffler mounting B bolt  
 (5) washer  
 (6) left muffler

## Muffler Installation

(CRF450R/RX)

- Remove the current gasket (1).
- Install a new gasket onto the exhaust pipe (2).
- Align the cutout (3) of the left muffler (4) with the tab (5) of the left muffler clamp (6).
- Install the left muffler.

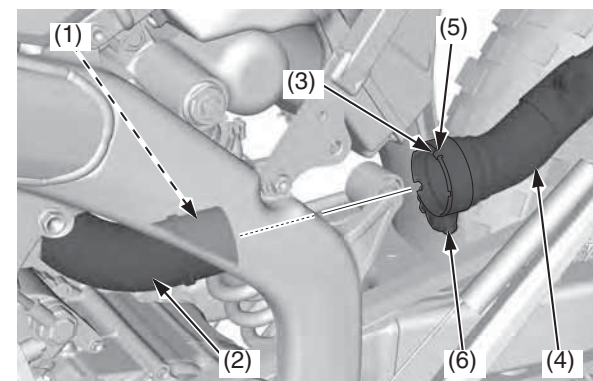

(1) gasket  
 (2) exhaust pipe  
 (3) cutout  
 (4) left muffler  
 (5) tab  
 (6) left muffler clamp

- Install the washer (7), left muffler mounting B bolt (8) and A bolt (9).

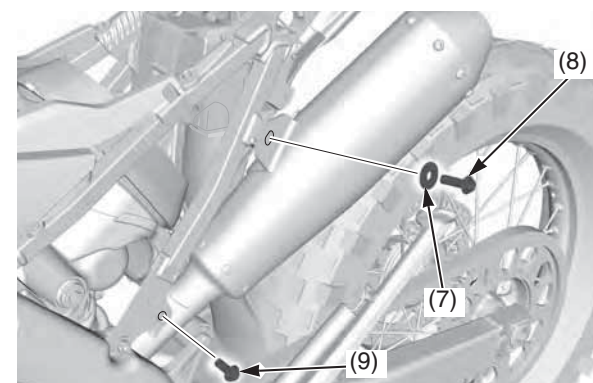

(7) washer  
 (8) left muffler mounting B bolt  
 (9) left muffler mounting A bolt



## Exhaust Pipe/Muffler

6. Tighten the left muffler clamp bolt (10) to the specified torque:  
15 lbf-ft (20 N·m, 2.0 kgf·m)

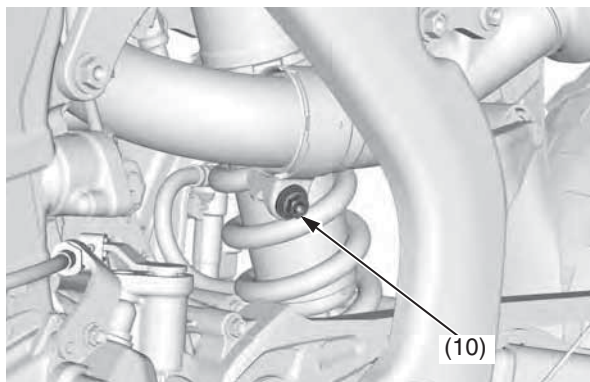

(10) left muffler clamp bolt

7. Remove the current gasket (1).  
8. Install a new gasket onto the exhaust pipe (2).  
9. Align the cutout (3) of the right muffler (11) with the tab (5) of the right muffler clamp (12).  
10. Install the right muffler (11).

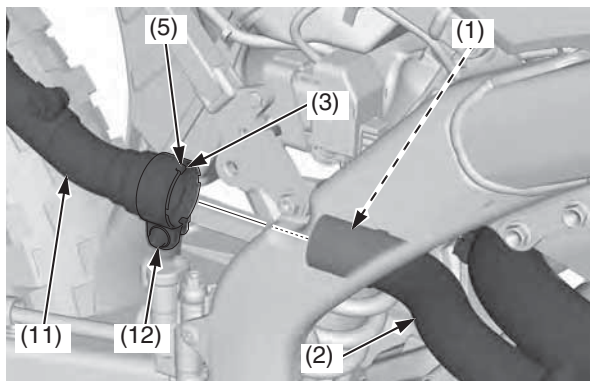

(1) gasket  
(2) exhaust pipe  
(3) cutout  
(5) tab  
(11) right muffler  
(12) right muffler clamp

11. Install the washer (13), right muffler mounting B bolt (14) and A bolt (15).

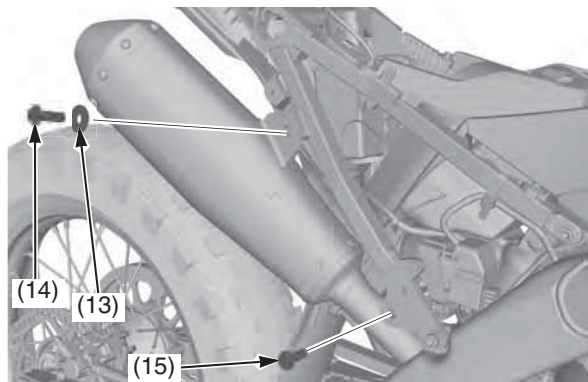

(13) washer  
(14) right muffler mounting B bolt  
(15) right muffler mounting A bolt

12. Tighten the right muffler clamp bolt (16) to the specified torque:  
15 lbf-ft (20 N·m, 2.0 kgf·m)

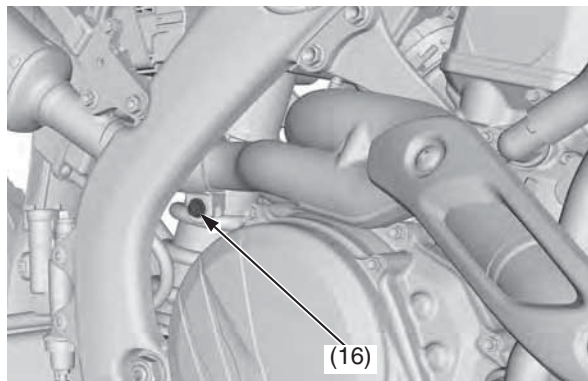

(16) right muffler clamp bolt

13. Tighten the right muffler mounting B bolt (14) and A bolt (15) to the specified torque:  
19 lbf-ft (26 N·m, 2.7 kgf·m)

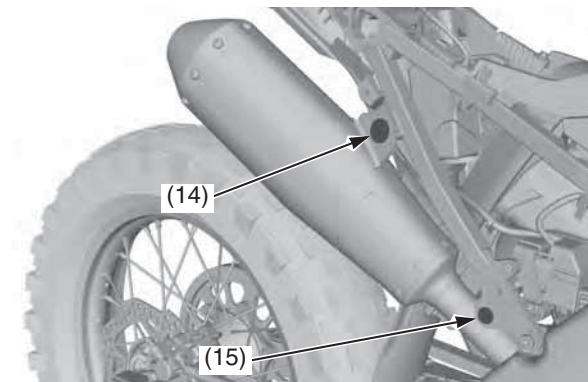

(14) right muffler mounting B bolt  
(15) right muffler mounting A bolt

14. Tighten the left muffler mounting B bolt (8) and left muffler mounting A bolt (9) to the specified torque:  
19 lbf-ft (26 N·m, 2.7 kgf·m)

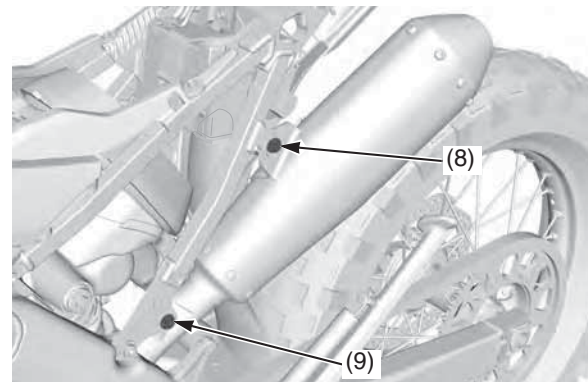

(8) left muffler mounting B bolt  
(9) left muffler mounting A bolt

15. Install the air cleaner housing covers (17) and side covers (18), and then tighten the bolts (19) to the specified torque:  
7 lbf-ft (10 N·m, 1.0 kgf·m)

The procedure is the same for the both right and left side

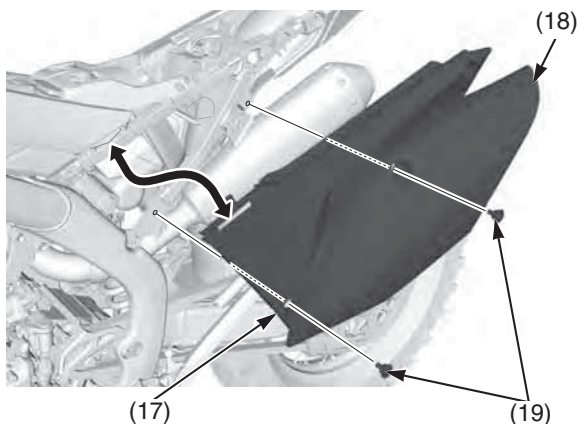

(17) air cleaner housing covers (19) bolts  
(18) side covers

16. Install the seat (page 34).

(CRF450RWE)

1. Install the left muffler (1), the washer (2) and left muffler mounting B bolt (3) but do not tighten the bolt yet.

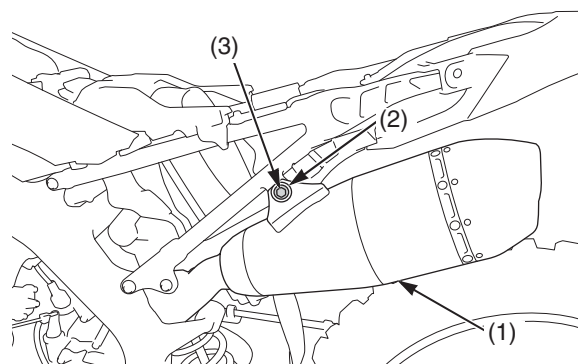

(1) left muffler  
(2) washer  
(3) left muffler mounting B bolt

2. Install the right muffler (4), the washer (5) and right muffler mounting B bolt (6) but do not tighten the bolt yet.

Tighten the right and left muffler mounting B bolts to the specified torque:  
19 lbf-ft (26 N·m, 2.7 kgf·m)

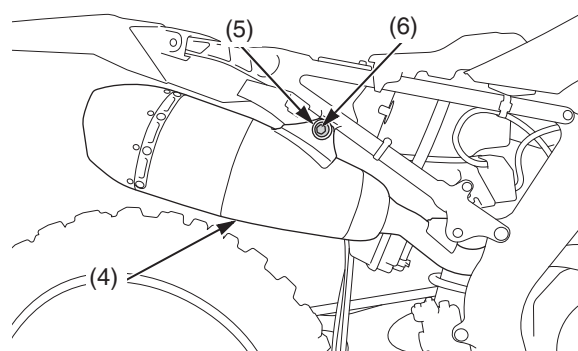

(4) right muffler  
(5) washer  
(6) right muffler mounting B bolt

3. Install the air cleaner housing covers and side covers (this page).  
4. Install the seat (page 34).

## Exhaust Pipe Removal

(CRF450R/RX)

1. Remove the right and left mufflers (page 126).  
2. Remove the exhaust pipe joint nuts (1), exhaust pipe (2) and gasket (3).

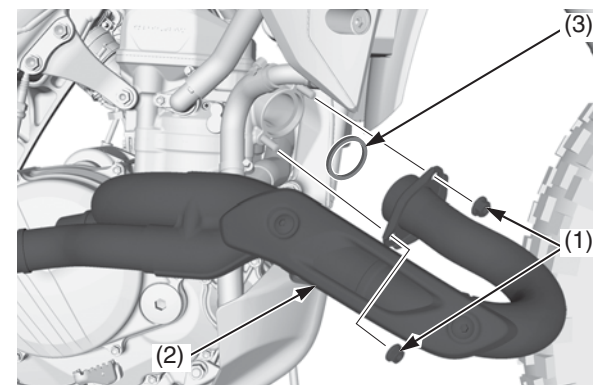

(1) exhaust pipe joint nuts  
(2) exhaust pipe  
(3) gasket



# Exhaust Pipe/Muffler

(CRF450RWE)

1. Remove the right and left muffler (page 127).
2. Remove the right exhaust spring A (1).
3. Remove the right muffler mounting A bolt (2) and right muffler joint pipe (3).

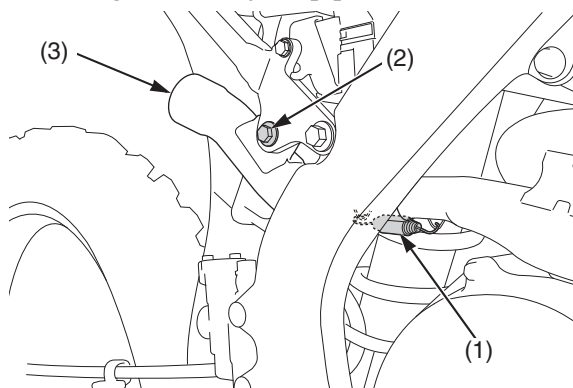

- (1) right exhaust spring A  
(2) right muffler mounting A bolt  
(3) right muffler joint pipe

4. Remove the upper drive chain roller (4) (page 123).
5. Remove the left exhaust spring A (5).
6. Remove the left muffler mounting A bolt (6) and left muffler joint pipe (7).

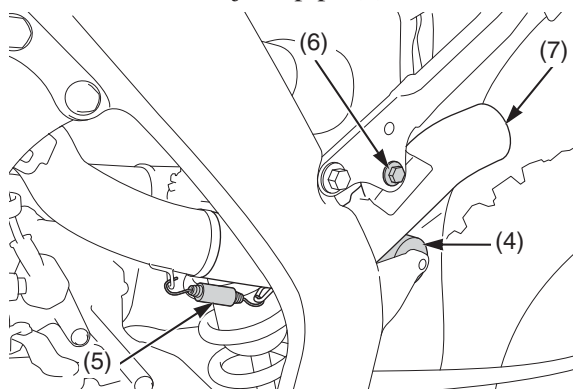

- (4) upper drive chain roller  
(5) left exhaust spring A  
(6) left muffler mounting A bolt  
(7) left muffler joint pipe

7. Remove the exhaust springs B (8).
8. Remove the exhaust pipe joint nuts (9).
9. Remove the exhaust pipe (10), sleeve (11) and exhaust pipe flange (12) as a set.
10. Remove the gasket (13).

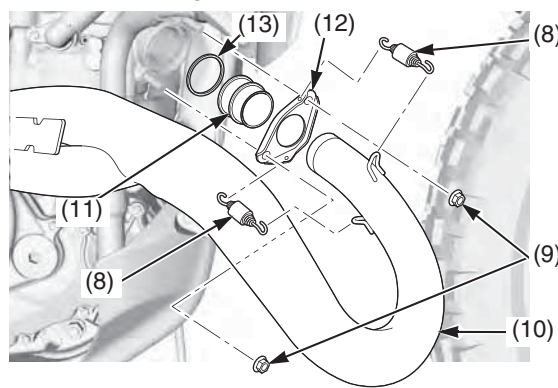

- (8) exhaust springs B  
(9) exhaust pipe joint nuts  
(10) exhaust pipe  
(11) sleeve  
(12) exhaust pipe flange  
(13) gasket

## Exhaust Pipe Installation

(CRF450R/RX)

1. Install a new exhaust pipe gasket (1).
2. Install the exhaust pipe (2) and exhaust pipe joint nuts (3) but do not tighten the nuts yet.

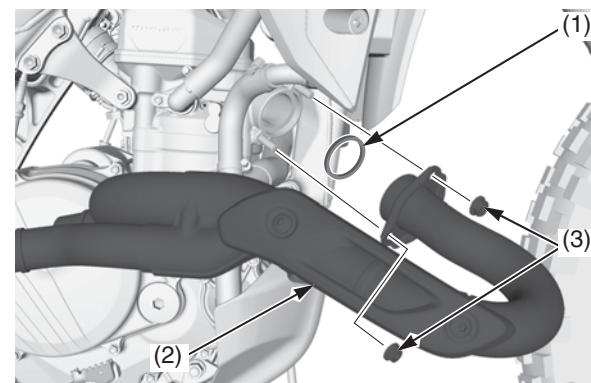

- (1) exhaust pipe gasket (new)  
(2) exhaust pipe  
(3) exhaust pipe joint nuts

3. Install the left and right mufflers (page 129) but do not tighten the bolts yet.
4. Tighten the exhaust pipe joint nuts to the specified torque:  
**15 lbf-ft (20 N·m, 2.0 kgf·m)**
5. Tighten the left muffler clamp bolt, left muffler mounting A bolt and B bolt (page 127).
6. Tighten the right muffler clamp bolt, right muffler mounting A bolt and B bolt (page 127).

(CRF450RWE)

1. Install the exhaust pipe flange (1) and sleeve (2) to the exhaust pipe (3) if removed.
2. Install a new exhaust pipe gasket (4), exhaust pipe and exhaust pipe joint nuts (5) but do not tighten the nut yet.
3. Set the exhaust springs B (6) to the exhaust pipe flange.

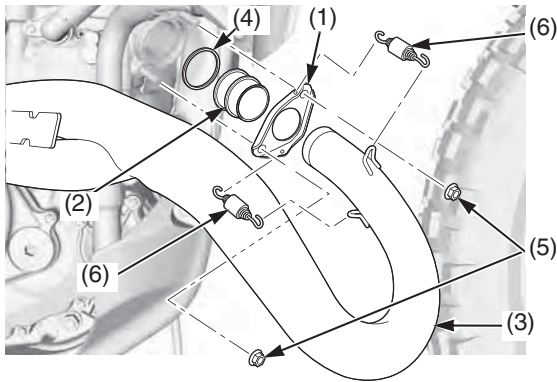

- (1) exhaust pipe flange
- (2) sleeve
- (3) exhaust pipe
- (4) exhaust pipe gasket (new)
- (5) exhaust pipe joint nuts
- (6) exhaust springs B

4. Attach the left muffler joint pipe (7) and install the left muffler mounting A bolt (8) but do not tighten the bolt yet.
5. Attach the right muffler joint pipe (9) and install the right muffler mounting A bolt (10) but do not tighten the bolt yet.
6. Install the left and right muffler but do not tighten the bolts yet (page 129).
7. Tighten the exhaust pipe joint nuts to the specified torque:  
15 lbf·ft (20 N·m, 2.0 kgf·m)
8. Tighten the right and left muffler mounting A bolts to the specified torque:  
19 lbf·ft (26 N·m, 2.7 kgf·m)
9. Tighten the right and left muffler mounting B bolts to the specified torque:  
19 lbf·ft (26 N·m, 2.7 kgf·m)

10. Install the left and right exhaust springs A (11).
11. Install the upper drive chain roller (12) (page 123).

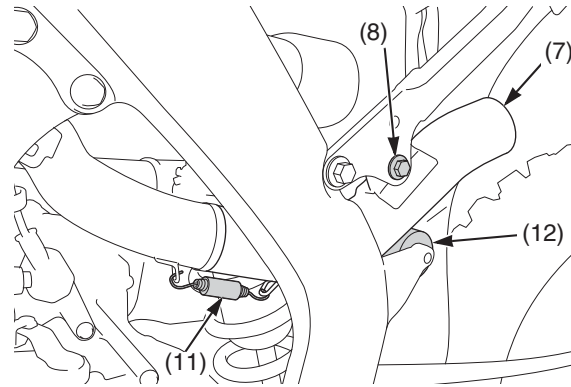

- (7) left muffler joint pipe
- (8) left muffler mounting A bolt
- (11) left exhaust springs A
- (12) upper drive chain roller

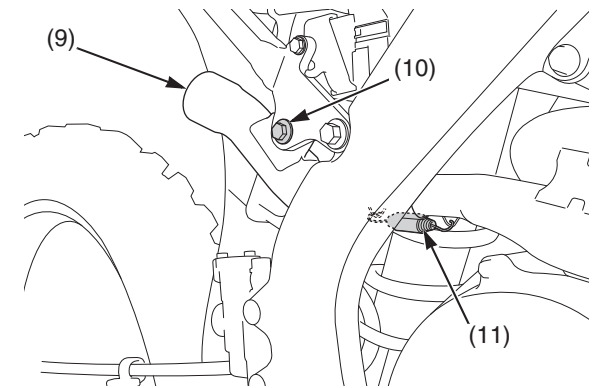

- (9) right muffler joint pipe
- (10) right muffler mounting A bolt
- (11) right exhaust springs A

12. Install the exhaust spring B to the exhaust pipe.
13. Install the air cleaner housing covers and side covers (page 129).
14. Install the seat (page 34).

## Additional Maintenance Procedures

Refer to *Important Safety Precautions* on page 23.

### Steering Head Bearing Inspection

1. With your CRF on an optional workstand or equivalent support (front wheel elevated), turn the handlebar to the right and left to check for roughness in the steering head bearings.

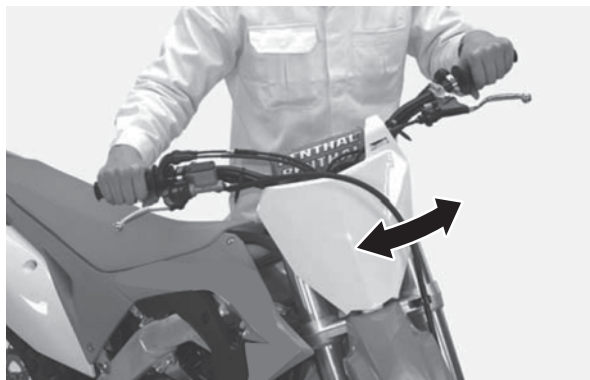

2. Stand in front of your CRF, grab the fork (at the axle), look at the steering head, and push the fork in and out (toward the engine) to check for play in the steering head bearings.

If any roughness or play is felt, but you do not see any movement in the steering head, the fork bushings may be worn.

Refer to an official Honda Service Manual for replacement or adjustment procedures, or see your dealer.



### Handlebar Inspection

1. Remove the handlebar protector and check the handlebar (1) for bends or cracks.
2. Check that the handlebar has not moved from its original position where the end of the left handlebar holders (2) is aligned with the paint mark (3).
3. Check the torque of the handlebar upper holder bolts (4):  
16 lbf-ft (22 N·m, 2.2 kgf·m)  
Tighten the front bolts first.
4. Install the handlebar protector.

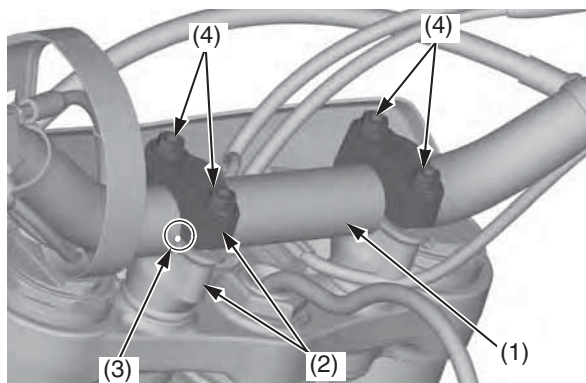

- (1) handlebar
- (2) left handlebar holders
- (3) paint mark
- (4) handlebar upper holder bolts

### Control Cables

Periodically, disconnect the clutch cables at their upper ends. Thoroughly lubricate the cable pivot points with a commercially available cable lubricant. If the clutch lever and throttle operation is not smooth, replace the cable.

Be sure the throttle returns freely from fully open to fully closed automatically, in all steering positions.

## Nuts, Bolts, Fasteners

Check and tighten nuts, bolts, and fasteners before every outing.

### ENGINE

Item	Torque		
	lbf-ft	N-m	kgf-m
1 Cylinder head cover socket bolts	7	10	1.0
2 Clutch cover bolts	7	10	1.0
3 Water pump cover bolts	7	10	1.0
4 Crankshaft hole cap	11	15	1.5
5 Oil filter cover bolts	7	10	1.0
6 Cylinder head bolts	37	50	5.1
7 Exhaust pipe joint nuts	15	20	2.0
8 Drive sprocket bolt	23	31	3.2
9 Engine oil drain bolt	13	18	1.8
10 Coolant drain bolt	7	10	1.0

### RIGHT SIDE

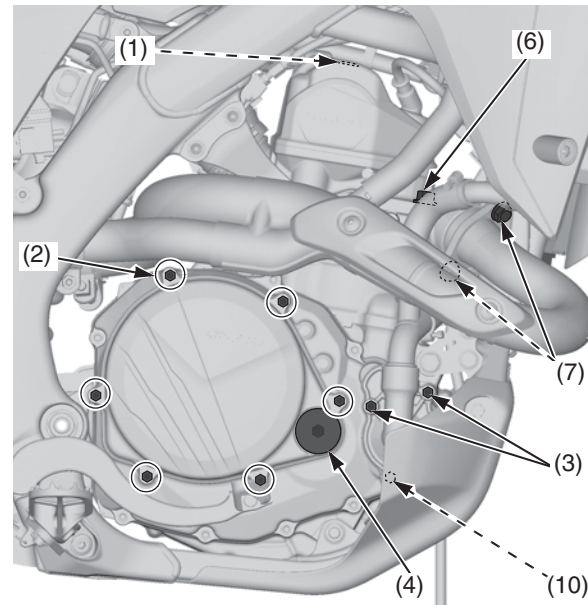

- (1) cylinder head cover socket bolts
- (2) clutch cover bolts
- (3) water pump cover bolts
- (4) crankshaft hole cap
- (6) cylinder head bolts
- (7) exhaust pipe joint nuts
- (10) coolant drain bolt

### LEFT SIDE

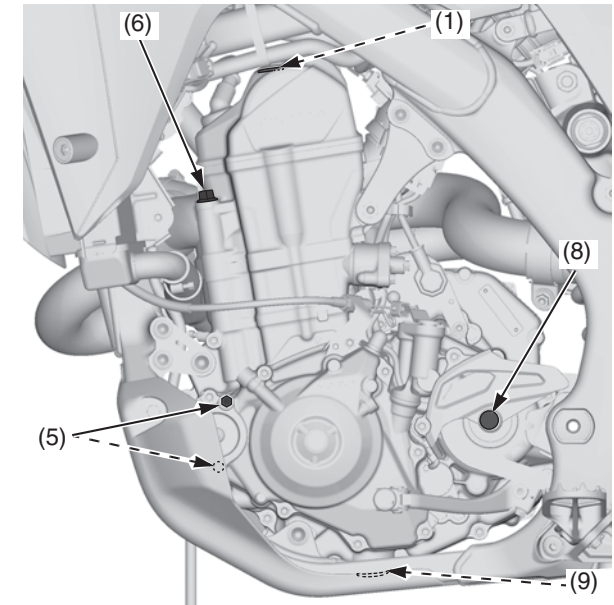

- (1) cylinder head cover socket bolts
- (5) oil filter cover bolts
- (6) cylinder head bolts
- (8) drive sprocket bolt
- (9) engine oil drain bolt



# Battery

Refer to *Important Safety Precautions* on page 23.

Your CRF has a lithium-ion (li-ion) battery. Clean the battery terminals if they become dirty or corroded.

## NOTICE

*An improperly disposed of battery can be harmful to the environment and human health. Always confirm local regulations for proper battery disposal instruction.*

Power of the start button uses current from the battery.

Limited operation also allows the battery to discharge. If you do not ride frequently, we recommend that you charge the battery frequently (see *Battery Charging* on page 135).

If you plan to store your CRF, see *Battery Storage* (this page).

If your battery seems weak and/or is leaking electrolyte (cause slow starting), see your dealer. If you smell an unusual odor coming from the lithium-ion (li-ion) battery, park your CRF in a safe place outside and away from flammable objects, then push and hold the engine stop button until the engine stops completely.

The battery has a limited life span. Consult your dealer about when you should replace the battery. Always replace the battery with another lithium-ion (li-ion) battery of the same type.

The lithium-ion (li-ion) battery contains a fuse inside.

If the fuse blows, the battery needs replacement. The voltage may read above 12V even with a blown battery fuse when the battery is unmounted (page 169).

## Battery Storage

Before you remove the battery, be sure to read all the information that follows, as well as the information on the battery label.

### ⚠ WARNING

The battery contains flammable organic solvent as electrolyte.

You can be burned or seriously injured if the battery is handled improperly.

- Keep the battery away from heat, sparks, and flame.
- Keep the battery out of the reach of children.
- Do not disassemble or modify the battery or battery terminals.
- Do not short-circuit the battery with metal tools or other metal objects.
- Do not subject the battery to impacts.

If you do not remove the battery, we recommend disconnecting the battery cables (negative cable first).

The battery is located under the seat.

## Removal

1. Remove the seat (page 34).
2. Remove the battery band (1).
3. Disconnect the negative (-) terminal (2).
4. Remove the positive terminal cover (3).
5. Disconnect the positive (+) terminal (4) and remove the battery (5).

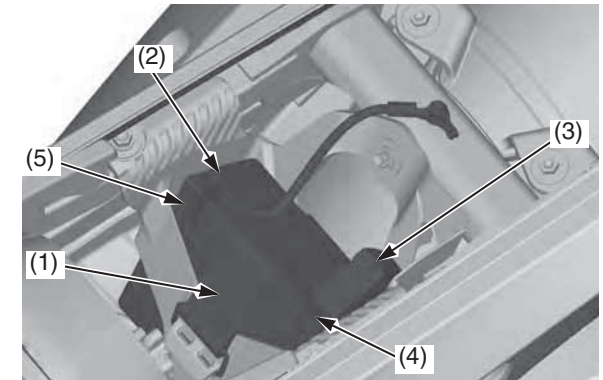

- (1) battery band                      (4) positive (+) terminal  
(2) negative (-) terminal          (5) battery  
(3) positive terminal cover

6. Unless you have been riding regularly, charge the battery (page 135).
7. Store your battery in an easy-to-reach location off the floor, in an area protected from freezing temperatures and direct sunlight.
8. Clean the battery box after removing the battery for storage. Dry the battery box.
9. Slow charge the battery (page 135) once every 30 days.



## Installation

1. Reinstall the battery (1) in the reverse order of removal. Be sure to connect the positive (+) terminal first, then the negative (-) terminal.
2. Tighten the positive (+) terminal bolt (2) and negative (-) terminal bolt (3) to the specified torque:  
1.5 lbf·ft (2.0 N·m, 0.2 kgf·m)
3. Install the battery band (4).
4. Install the positive terminal cover (5).

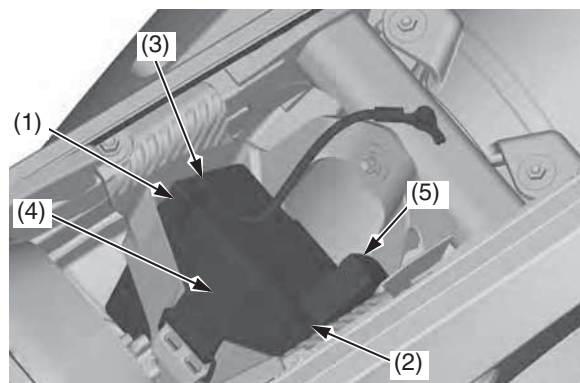

- (1) battery (4) battery band  
(2) positive (+) terminal bolt (5) positive terminal cover  
(3) negative (-) terminal bolt

## Battery Charging

Be sure to read the information that came with your battery charger and follow the instructions on the battery. Improper charging may damage the battery.

We recommend using a charger recommended by your lithium-ion (li-ion) battery manufacturer which can be purchased from your dealer. These units can be left connected for long periods without risking damage to the battery. However, the lithium-ion (li-ion) battery may degrade if stored with a charger connected. Do not intentionally leave the charger connected longer than the time period recommended in the charger's instructions.

Using an existing lead-acid battery charger or battery charger that is not recommended, will damage the electrical circuits within the Li-ion battery.

## Appearance Care

Refer to *Important Safety Precautions* on page 23.

Frequent cleaning and polishing will keep your CRF looking newer longer. Frequent cleaning also identifies you as an owner who values his motorcycle. A clean CRF is also easier to inspect and service.

While you're cleaning, be sure to look for damage, wear, and gasoline or oil leaks.

### General Recommendations

- To clean your CRF you may use:
  - water
  - Hondabrite
  - a mild, neutral detergent and water
  - a mild spray and wipe cleaner/polisher
  - a mild spray and rinse cleaner/degreaser and water
- Avoid products that contain harsh detergents or chemical solvents that could damage the metal, paint, and plastic on your CRF or discolor the seat and decals.
- If your CRF is still warm from recent operation, give the engine and exhaust system time to cool off.
- We recommend the use of a low pressure garden hose to wash your CRF. High pressure washers (like those at coin-operated car washes) can damage certain parts of your CRF. The force of water under extreme pressure can penetrate the dust seals of the suspension pivot points and steering head bearings-driving dirt inside and needed lubrication out.

If you use a high pressure washer, avoid spraying the following areas:

- brake master cylinders
- drive chain
- electrical circuit
- engine stop button
- muffler outlet
- steering head bearings (1)
- suspension pivot points (2)
- throttle body
- under fuel tank
- under seat

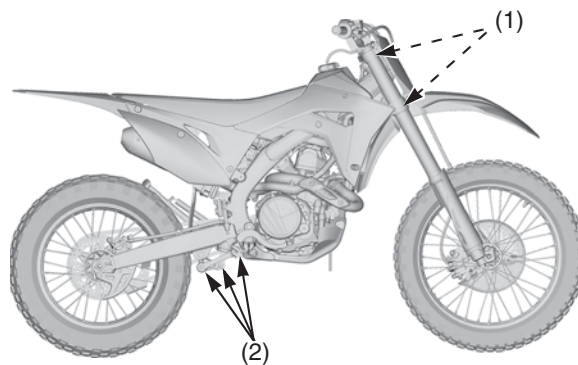

- (1) steering head bearings  
(2) suspension pivot points

### NOTICE

*High pressure water (or air) can damage certain parts of your CRF.*

You may use Pro Honda Hondabrite, a multi-surface cleaner/degreaser, to remove both dirt and petroleum-based grime from paint, alloy, plastic, and rubber surfaces. Wet any heavy deposits with water first. Then spray on Pro Honda Hondabrite and rinse with a low pressure garden hose at full pressure. Stubborn deposits may require a quick wipe with a sponge.

### Washing Your Motorcycle with a Mild Detergent

Allow the engine, muffler, brakes, and other high-temperature parts to cool before washing.

1. Rinse your CRF thoroughly using a low pressure garden hose to remove loose dirt.
2. Fill a bucket with cool water. Mix in a mild, neutral detergent, such as dish washing liquid or a product made especially for washing motorcycles or automobiles.
3. Wash your CRF with a sponge or a soft towel. As you wash, check for heavy grime. If necessary, use a mild cleaner/degreaser to remove the grime.

### NOTICE

*Do not use steel wool to clean the frame as it could damage or discolor the frame surface. Muffler stain remover (Scotch Brite Hand Pad #7447-maroon) is for removing stains on the non-coated aluminum frame only.*

4. After washing, rinse your CRF thoroughly with plenty of clean water to remove any residue. Detergent residue can corrode alloy parts.
5. Dry your CRF with a chamois or a soft towel. Leaving water on the surface to air dry can cause dulling and water spots. As you dry, inspect for chips and scratches.
6. Lubricate the drive chain to prevent rusting.
7. Start the engine and let it idle for several minutes. The engine heat will help dry moist areas.
8. As a precaution, ride at a slow speed and apply the brakes several times. This will help dry the brakes and restore normal braking performance.

## After Cleaning Lubrication

There are some things you should do just after washing your CRF to help prevent rust and corrosion.

Once your CRF is clean and dry, you should protect any bare steel from rusting by applying a light coating of a rust-inhibitor. Lubricate the drive chain and drive sprocket after removing and thoroughly cleaning in solvent. Be sure the chain is wiped clean and is dry before applying the chain lube.

Follow the suggestions given in the pages of this manual for lubricating items such as the brake and clutch lever pivot points and footpeg pivot pins.

## Aluminum Frame Maintenance

Aluminum corrodes when it comes in contact with dust, mud and road salt.

To remove stains, use Scotch Brite Hand Pad #7447 (maroon) or an equivalent.

Wet the pad and polish the surface using strokes parallel to the length of the frame.

Clean the frame using a wet sponge and a mild detergent, then rinse well with clean water. Dry the frame with a soft clean cloth, using strokes parallel to the length of the frame.

### NOTICE

*Do not use steel wool to clean the frame as it could damage or discolor the frame surface.*

*Scotch Brite Hand Pad #7447-maroon is for removing stains on the non-coated aluminum frame only.*

## Titanium Fuel Tank Maintenance (CRF450R/RWE)

The fuel tank is made of titanium material.

To remove mud or dust, use a sponge or soft cloth and a stainless steel kitchen detergent, then rinse well with clean water.

After washing, rinse with plenty of water and dry with a clean cloth.

## Exhaust Pipe and Muffler Maintenance

The exhaust pipe and muffler are titanium (CRF450RWE only) and stainless steel but may become stained by mud or dust.

To remove mud or dust, use a wet sponge and a liquid kitchen abrasive, then rinse well with clean water. Dry with chamois or a soft towel.

If necessary, remove heat stains by using a commercially available fine texture compound. Then rinse by the same manner as removing mud or dust.

BLANK PAGE

This section tells you how to fine tune your CRF for maximum competition performance.

Initial suspension adjustments should be performed after a minimum of 2 hours of easy break-in time.

Optional front and rear suspension springs are available in order to tailor your CRF specifically for your weight, riding style and course conditions.

Follow the instructions given in the rear suspension sag setting section of *Rear Suspension Adjustments* to determine if your combined rider and sprung machine weight (rider fully dressed for competition and machine coolant, oil and fuel levels ready for competition) requires an optional stiffer or softer rear spring. The need for either optional rear spring may need to be balanced by installing the optional fork springs of a similar rate.

Engine Mode Select Button .....	140
Current Mode .....	140
Mode Selection .....	140
Honda Selectable Torque Control.....	141
Current Mode .....	141
Mode Selection .....	141
HRC-Launch Control System .....	142
Front Suspension Adjustments .....	143
Front Suspension Air Pressure.....	143
Front Suspension Damping.....	144
Fork Springs.....	144
Fork Oil Adjustment .....	145
Rear Suspension Adjustments.....	146
Rear Suspension Spring Pre-Load .....	146
Rear Suspension Damping.....	147
Rear Suspension Race Sag.....	149
Suspension Adjustments for	
Track Conditions.....	151
Suspension Adjustment Guidelines .....	152
Tuning Tips.....	155
Spark Plug Reading .....	155
Chassis Adjustments .....	156
Rear End .....	156
Fork Height/Angle .....	156
Wheelbase.....	156
Gearing.....	157
Tire Selection for Track Conditions .....	158
Personal Fit Adjustments .....	159
Control Positioning.....	159
Handlebar Position, Width & Shape.....	159



# Engine Mode Select Button

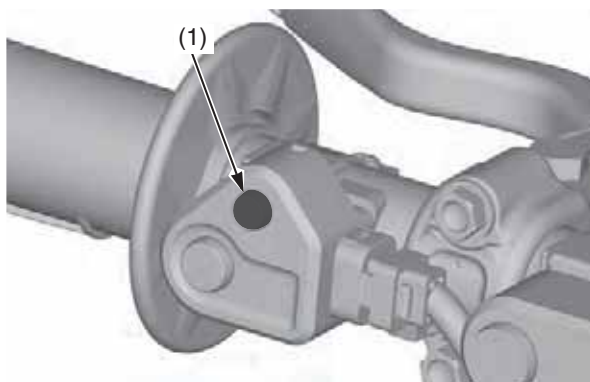

(1) engine mode select button

You can change engine output characteristic depending on track conditions by using the engine mode select button (1).

- PGM-FI mode 1: standard setting
- PGM-FI mode 2: smooth setting (reduce throttle response from the standard setting)
- PGM-FI mode 3: aggressive setting (increase throttle response from the standard setting)

## Current Mode

Start the engine and push the engine mode select button (1) with your CRF stopped. The engine mode indicator (2) under the engine mode select button indicates the selected mode by blinking the mode number in blue 3 times.

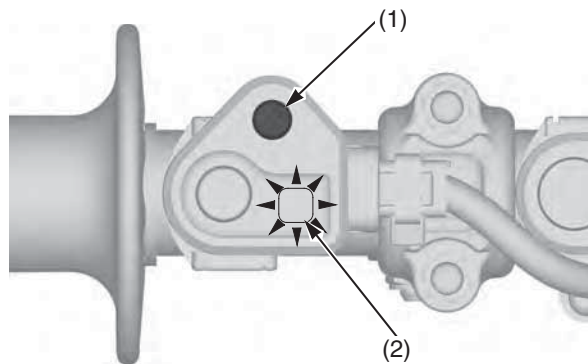

(1) engine mode select button  
(2) engine mode indicator (blue)

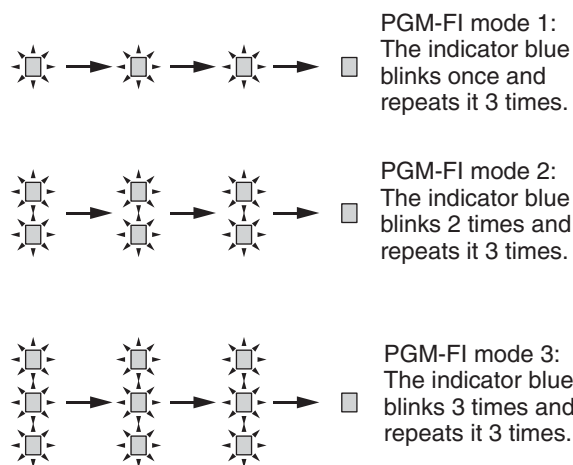

## Mode Selection

1. Start the engine.
2. With your CRF stopped and the throttle closed, push and hold the engine mode select button for 1 or more second.

Make sure that the fast idle knob is pushed in (page 17). If the fast idle knob is pulled out, the engine mode will not change.

3. Release the engine mode select button. The engine mode indicator will indicate a selected mode by the number of times the indicator blue blinks.
4. Repeat steps 2 – 3 until the desired mode is indicated.

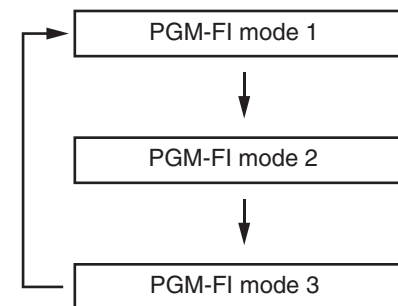

# Honda Selectable Torque Control

The Honda selectable torque control reduces slip and assists for an effective acceleration by temporarily decreasing the engine torque during rear wheel spin.

Torque Control level can be selected or turned on/off, according to your skill and track conditions by using the Torque Control button (1).

The Torque Control indicator (2) (green) comes on while the system is operating.



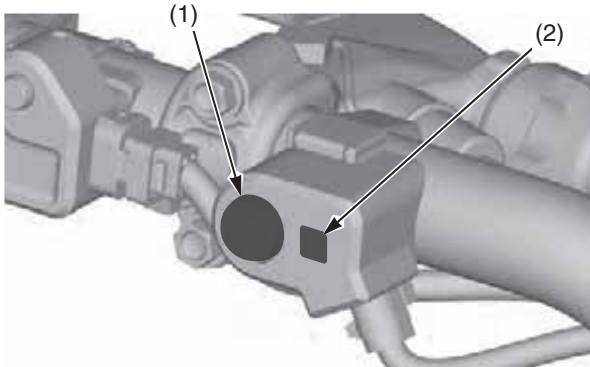

Torque Control mode	Rear wheel slip
1	High
2	Middle
3	Low
OFF	No operation



(1) Torque Control button  
(2) Torque Control indicator (green)

## Current Mode

Start the engine.  
The Torque Control indicator indicates the selected mode by blinking the mode number 3 times.

-  — Torque Control mode 1:  
The indicator short blinks once and repeats it 3 times.
-  — Torque Control mode 2:  
The indicator short blinks 2 times and repeats it 3 times.
-  — Torque Control mode 3:  
The indicator short blinks 3 times and repeats it 3 times.
-  — Torque Control off:  
The indicator does not light up.

## Mode Selection

- Start the engine.
- Press the Torque Control button to select a mode level. The mode changes every time you press the button.
  - The Torque Control indicator (green) will indicate a selected mode by the number of times the indicator blinks.
  - The last mode selected will be saved.
  - The factory setting is mode 2.
  - Torque Control can be turned on and off by press and hold the Torque Control button.

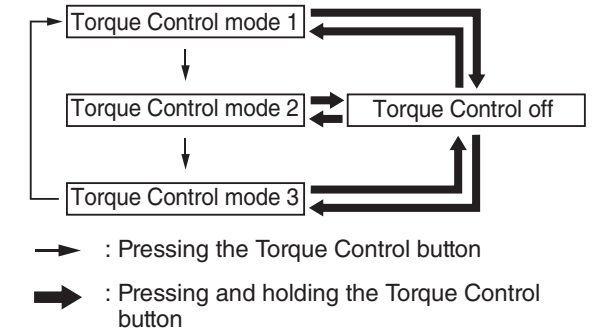

# HRC-Launch Control System

The HRC-Launch Control System reduces slip and assists for an effective start by temporarily decreasing the rev limit and Torque Control operation when starting.

You can select the level while the system is operating according to your skill and track conditions.

## To change the level

1. Start the engine and wait more than 2 seconds.
2. Close the throttle completely, press and hold the start button (1) while pulling the clutch lever in until the launch control system indicator (2) blinks (purple).
  - The system goes into standby, and the launch control system indicator indicates the selected level by blinking (purple).
  - From standby, the control to decrease the rev limit starts.
  - The system may become disabled if you snap the throttle excessively.
  - If the idle speed is low, the system may not go into standby. Set the idle speed to standard rpm, see page 72.
  - To disable the system, quickly press the start button. The launch control system indicator stops blinking.

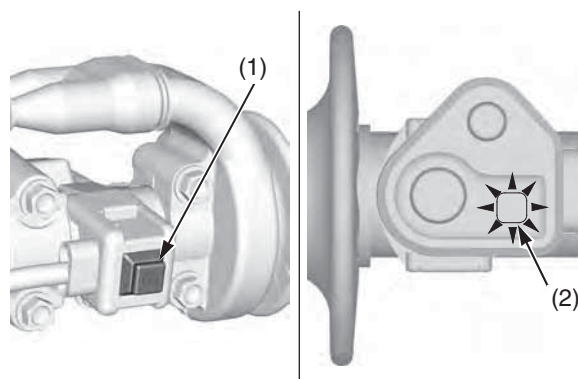

(1) start button  
(2) launch control system indicator (purple)

3. Press and hold the start button. The level changes every time you press and hold.
  - The level selected last is saved.
  - The factory setting is level 2.

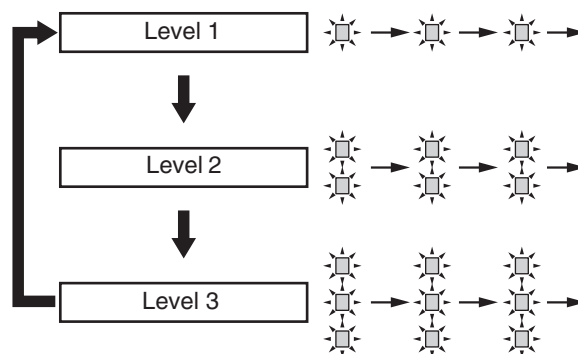

➡ : Pressing and holding the start button while the launch control system is in standby

Level	Rev limit during launch control	Rear wheel slip	Number of launch control system indicator blinks
1	High	High	1
2	Middle	Middle	2
3	Low	Low	3

4. To continue using the system, refer to step 2 in *To operate the system*.  
To disable the system, quickly press the start button. The launch control system indicator stops blinking and the system is disabled.

## To operate the system

1. Perform steps 1 and 2 in *To change the level*.
2. Shift into 1st or 2nd gear.
3. When launching, open the throttle halfway or more. The system operates.
  - The reduced rev limit and engine torque is controlled and will gradually return to normal in a few seconds. Once the rev limit returns to normal, the system is disabled.
  - The launch control system indicator comes on (purple) while the system is operating.
  - If you open the throttle halfway or more before starting, control system stops before starting and there is no effect.
  - If you close the throttle immediately, the system may not operate.
  - When the launch control system operates, these following conditions will disable launch control:
    - Vehicle is in 3rd gear
    - The throttle completely closed
4. Make sure that the launch control system indicator is off. If it is not off, the system is not disabled. Quickly press the start button to disable the system.

The front suspension can be adjusted for the rider's weight and riding conditions by using one or more of the following methods:

- **Oil volume** — The effects of higher or lower fork oil capacity are only felt during the final 3.9 in (100 mm) of fork travel.
- **Compression damping** — Turning the compression damping adjuster (1) adjusts how quickly the fork compresses.
- **Rebound damping** — Turning the rebound damping adjuster (2) adjusts how quickly the fork extends.
- **Fork springs** — Optional springs are available in softer and stiffer types than the standard rate. (page 181)

The inverted fork on your CRF features sealed damper cartridges with dual (separate air and oil) chambers to prevent aeration. The design also isolates the oil in each fork/damper, which may contain air bubbles and/or metal particles, from the sealed cartridge to provide more consistent damping.

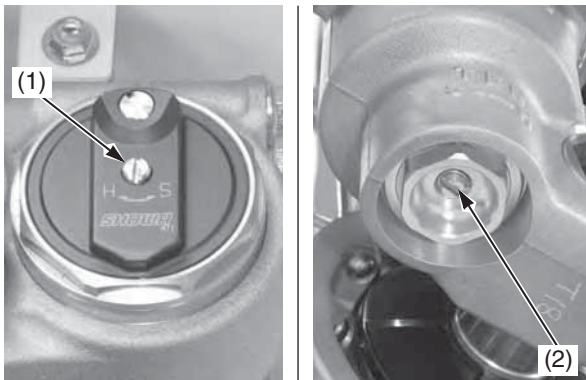

(1) compression damping adjuster  
(2) rebound damping adjuster

## Front Suspension Air Pressure

Air is an unstable gas which builds up pressure as it is worked (such as in a fork). Air pressure acts as a progressive spring and affects the entire range of fork travel. This means the fork action on your CRF will get stiffer during a race (CRF450RX)/moto (CRF450R/RWE). For this reason, release built-up air pressure in the fork legs between race (CRF450RX)/moto (CRF450R/RWE). Be sure the fork is fully extended with the front tire off the ground when you release the pressure.

The standard air pressure is 0 psi (0 kPa, 0 kgf/cm<sup>2</sup>). You may relieve accumulated air pressure in the fork legs by using the pressure release screws. The front wheel should be off the ground before you release the pressure. The air pressure should be adjusted according to the altitude and outside temperature.

1. Place an optional workstand under the engine, so that the front wheel is off the ground. Do not adjust air pressure with the front wheel on the ground as this will give false pressure readings.
2. Remove the pressure release screw (1).
3. Apply recommended fork oil to a new O-ring (2), and then install a new O-rings.
4. Install and tighten the pressure release screw to the specified torque:  
1.0 lbf-ft (1.3 N·m, 0.1 kgf·m)

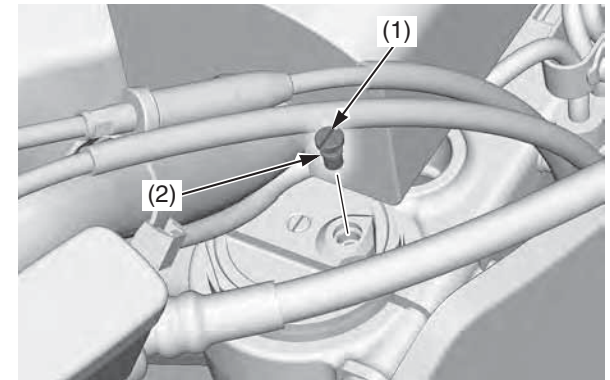

(1) pressure release screw (2) O-ring (new)

# Front Suspension Adjustments

## Front Suspension Damping

### Compression Damping Adjustment

This adjustment affects how quickly the fork compresses. The fork compression damping adjuster has 16 clicks or more. Turning the compression damping adjuster screw (1) one full turn changes the adjuster 4 clicks. To adjust the adjuster to the standard position, proceed as follows:

Turn the adjuster clockwise (harder) until it will no longer turn (lightly seats). Turn the adjuster counterclockwise (softer) until it clicks. This click is position 1.

The standard position is 8 clicks.

Make sure that both fork legs are adjusted to the same position.

### Rebound Damping Adjustment

This adjustment affects how quickly the fork extends.

The fork rebound damping adjuster has 16 clicks or more. Turning the rebound damping adjuster screw (2) one full turn changes the adjuster 4 clicks. To adjust the rebound damping to the standard setting, proceed as follows:

Turn the adjuster clockwise (harder) until it will no longer turn (lightly seats). Turn the adjuster counterclockwise (softer) until it clicks. This click is position 1.

(CRF450RX)

The standard position is 15 clicks.

(CRF450R/RWE)

The standard position is 9 clicks.

Make sure that both fork legs are adjusted to the same position.

## NOTICE

*Always start with full hard when adjusting damping.*

*Do not turn the adjuster screw more than the given positions or the adjuster may be damaged.*

*Be sure that the compression and rebound adjusters are firmly located in a detent, and not between positions.*

*Both compression and rebound damping can be increased by turning the adjuster clockwise.*

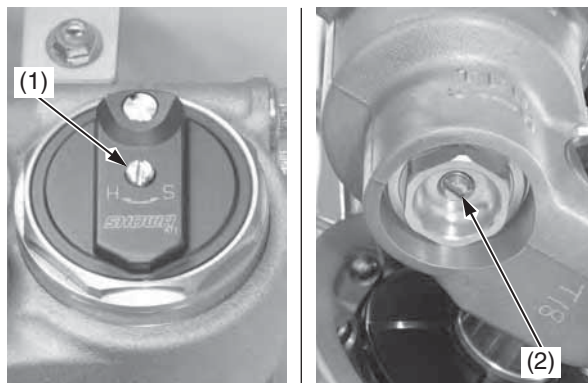

(1) compression damping adjuster screw  
(2) rebound damping adjuster screw

## Fork Springs

The fork springs in CRF's are about right for riders weighing between 170 lb (77 kg) and 200 lb (91 kg) (less riding gear). So if you're a heavier rider, you have to go up on the oil capacity or get a stiff spring. Do not use less oil than the minimum specified for each spring or there will be a loss of rebound damping control near full extension. If the fork is too stiff on big bumps, turn the compression damping adjuster counterclockwise 1-click and lower the oil capacity in increments of 0.2 US oz (5 cm<sup>3</sup>) in both fork legs until the desired performance is obtained. Do not, however, lower the oil capacity below the minimum oil capacity.

Minimum oil capacity (CRF450RX):

Standard spring:	10.5 US oz (309 cm <sup>3</sup> )
Soft spring:	10.4 US oz (307 cm <sup>3</sup> )
Stiff spring:	10.0 US oz (296 cm <sup>3</sup> )

Minimum oil capacity (CRF450R/RWE):

Standard spring:	10.3 US oz (304 cm <sup>3</sup> )
Soft spring:	10.5 US oz (309 cm <sup>3</sup> )
Stiff spring:	10.1 US oz (299 cm <sup>3</sup> )

When adjusting oil capacity, bear in mind that the air in the fork will increase in pressure while riding; therefore, the higher the oil capacity, the higher the eventual pressure of any air in the fork.



## Fork Oil Adjustment

1. Remove the front suspension (page 98).
2. Disassemble the fork outer tube (page 100).
3. Disassemble the fork damper (page 105).

### Fork Oil Capacity:

(CRF450RX)

Standard 27.4 lbf/in (4.8 N/mm) Fork Spring

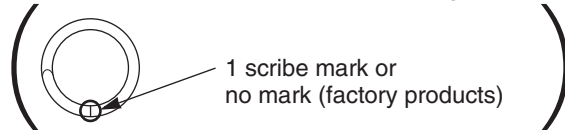

(CRF450R/RWE)

Standard 28.6 lbf/in (5.0 N/mm) Fork Spring

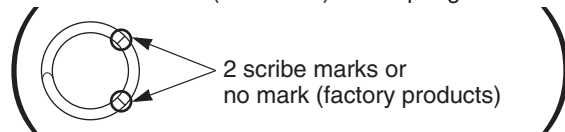

Standard oil capacity	CRF450RX	12.3 US oz (363 cm <sup>3</sup> )	
	CRF450R/RWE	12.0 US oz (356 cm <sup>3</sup> )	
Maximum oil capacity	CRF450RX	13.3 US oz (394 cm <sup>3</sup> )	Slightly stiffer as it nears full compression.
	CRF450R/RWE	13.2 US oz (389 cm <sup>3</sup> )	
Minimum oil capacity	CRF450RX	10.5 US oz (309 cm <sup>3</sup> )	Slightly softer as it nears full compression.
	CRF450R/RWE	10.3 US oz (304 cm <sup>3</sup> )	

Example: Front fork characteristics when a standard spring (CRF450RX)

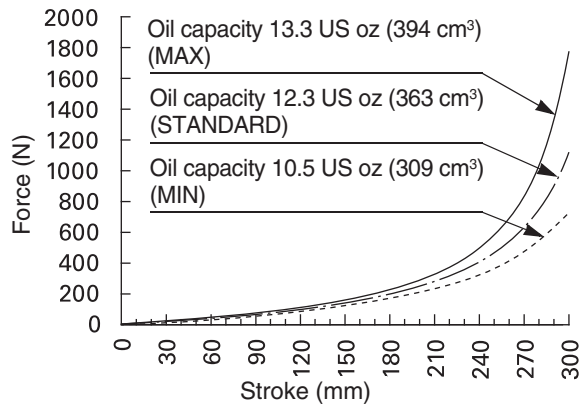

(CRF450R/RWE)

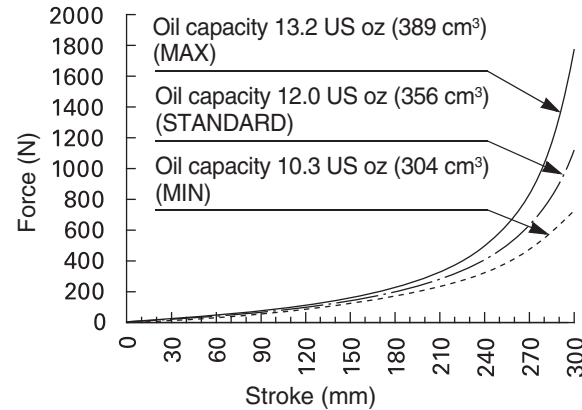

(CRF450RX)

Optional Soft 26.3 lbf/in (4.6 N/mm) Fork Spring

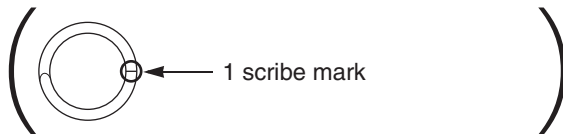

(CRF450R/RWE)

Optional Soft 27.4 lbf/in (4.8 N/mm) Fork Spring

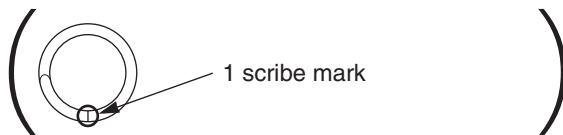

Standard oil capacity	CRF450RX	12.2 US oz (361 cm <sup>3</sup> )	
	CRF450R/RWE	12.2 US oz (361 cm <sup>3</sup> )	
Maximum oil capacity	CRF450RX	13.3 US oz (392 cm <sup>3</sup> )	Slightly stiffer as it nears full compression.
	CRF450R/RWE	13.3 US oz (394 cm <sup>3</sup> )	
Minimum oil capacity	CRF450RX	10.4 US oz (307 cm <sup>3</sup> )	Slightly softer as it nears full compression.
	CRF450R/RWE	10.5 US oz (309 cm <sup>3</sup> )	

(CRF450RX)

Optional Stiff 28.6 lbf/in (5.0 N/mm) Fork Spring

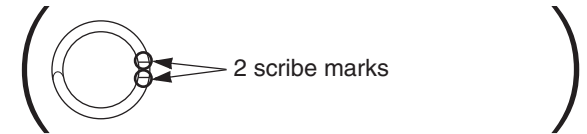

(CRF450R/RWE)

Optional Stiff 29.7 lbf/in (5.2 N/mm) Fork Spring

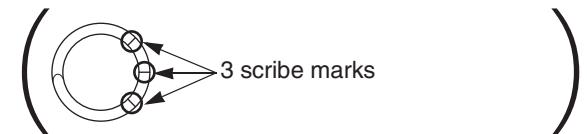

Standard oil capacity	CRF450RX	11.8 US oz (350 cm <sup>3</sup> )	
	CRF450R/RWE	11.8 US oz (350 cm <sup>3</sup> )	
Maximum oil capacity	CRF450RX	12.9 US oz (381 cm <sup>3</sup> )	Slightly stiffer as it nears full compression.
	CRF450R/RWE	13.0 US oz (383 cm <sup>3</sup> )	
Minimum oil capacity	CRF450RX	10.0 US oz (296 cm <sup>3</sup> )	Slightly softer as it nears full compression.
	CRF450R/RWE	10.1 US oz (299 cm <sup>3</sup> )	

4. Assemble the fork damper (page 110).
5. Refilling the fork oil (page 101).
6. Install the front suspension (page 102).

# Rear Suspension Adjustments

The rear suspension can be adjusted for the rider's weight and riding conditions by changing the spring pre-load and the rebound and compression damping.

The rear suspension assembly includes a damper unit that contains high pressure nitrogen gas. Do not attempt to disassemble, service, or dispose of the damper; see your dealer. The instructions found in this owner's manual are limited to adjustments of the shock assembly only.

Puncture or exposure to flame may also result in an explosion, causing serious injury. Service or disposal should only be done by your dealer or a qualified mechanic, equipped with the proper tools, safety equipment and an official Honda Service Manual.

If your CRF is new, put enough part-throttle break-in time (about 1 hour) on it to ensure that the suspension has worked in.

## Rear Suspension Spring Pre-Load

Pre-load should be adjusted when the engine is cold because it is necessary to remove the muffler. An optional pin spanner is available for turning the shock spring lock nut and adjusting nut to adjust spring pre-load.

1. Place your CRF on an optional workstand or equivalent support with the rear wheel off the ground.
2. Remove the subframe (page 39).
3. Remove the right muffler joint pipe (page 129). (CRF450RWE only)
4. Check that the spring pre-load is adjusted to the standard length. Adjust as necessary by loosening the shock spring lock nut (1) and turning the adjusting nut (2).

Each complete turn of the adjusting nut changes the spring length by 0.06 in (1.5 mm). After adjustment, hold the adjusting nut and tighten the shock spring lock nut to the specified torque:  
32 lbf·ft (44 N·m, 4.5 kgf·m)

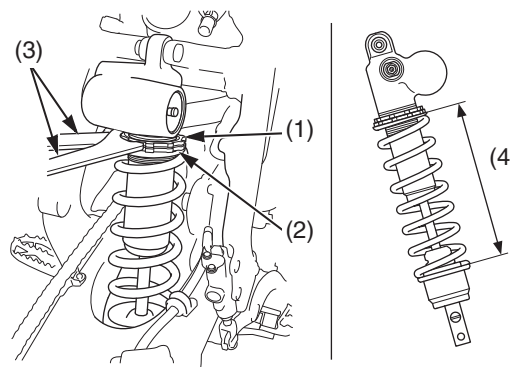

(1) shock spring lock nut      (3) pin spanners  
(2) adjusting nut              (4) spring length

Refer to the following pages for the installation procedure of the removed parts:

- air cleaner case and air cleaner connecting tube: page 41
- subframe: page 40

### To increase spring pre-load

Loosen the shock spring lock nut using the optional pin spanners (3) and turn the adjusting nut to shorten the spring length (4). Do not shorten to less than:

(CRF450RX)

Standard (Medium) spring (296.9 lbf/in (52 N/mm)):  
8.94 in (227.0 mm)

Optional Soft spring (285.5 lbf/in (50 N/mm)):  
8.94 in (227.0 mm)

Optional Stiff spring (308.3 lbf/in (54 N/mm)):  
9.07 in (230.5 mm)

(CRF450R/RWE)

Standard (Medium) spring (319.8 lbf/in (56 N/mm)):  
9.06 in (230.0 mm)

Optional Soft spring (308.3 lbf/in (54 N/mm)):  
9.07 in (230.5 mm)

Optional Stiff spring (331.2 lbf/in (58 N/mm)):  
9.13 in (232.0 mm)

## To decrease spring pre-load

Loosen the shock spring lock nut using the optional pin spanners (3) and turn the adjusting nut to increase the spring length (4). Do not increase to more than

9.41 in (239.0 mm)

Each turn of the adjusting nut changes spring length and spring pre-load. One turn equals: spring length/spring pre-load:

Standard: 0.06 in (1.5 mm)/18 lbf (78 N)

Pin spanners should be used for turning the shock spring lock nut and adjusting nut. See page 181 for optional pin spanners.

(CRF450RX)

Spring pre-load length (Standard (medium) spring)

Standard: 9.19 in (233.5 mm)

Max. : 9.41 in (239.0 mm)

Min. : 8.94 in (227.0 mm)

(CRF450R/RWE)

Spring pre-load length (Standard (medium) spring)

Standard: 9.33 in (237.0 mm)

Max. : 9.41 in (239.0 mm)

Min. : 9.06 in (230.0 mm)

## Rear Suspension Damping

### Compression Damping

Compression damping may be adjusted in two stages with separate adjusters.

The high speed compression damping adjuster (1) is effective when damping adjustment is desired for high speed operation. The low speed compression damping adjuster (2) should be used when damping adjustment is desired at relatively low speeds.

- When adjusting the compression damping adjusters, make sure to use the proper size tool to avoid damage.
- Both the high and low speed compression damping can be increased by turning the appropriate adjuster clockwise.
- Adjust the high speed compression damping adjuster in 1/4 turn increments.
- Be sure the high speed compression adjuster is firmly located in a detent, and not between positions.

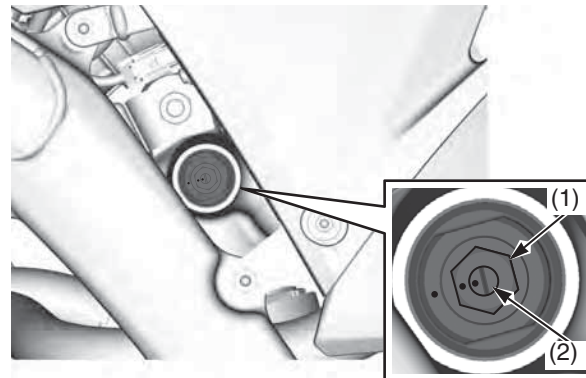

(1) high speed compression damping adjuster  
(2) low speed compression damping adjuster

### High Speed Damping:

The high speed damping can be adjusted by turning the hexagonal portion of the compression damping adjuster.

The high speed compression damping adjuster has 3 1/2 turns or more.

To adjust to the standard position:

1. Turn the adjuster clockwise (harder) until it will no longer turn (lightly seats).
2. (CRF450RX)  
Turn the adjuster counterclockwise (softer) 3 1/6 turns. Further turn it by  $\pm 1/4$ , align the punch mark (3) on the adjuster and the punch mark (4) on the adjuster body.

(CRF450R/RWE)

Turn the adjuster counterclockwise (softer) 3 turns. Further turn it by  $\pm 1/4$ , align the punch mark (3) on the adjuster and the punch mark (4) on the adjuster body.

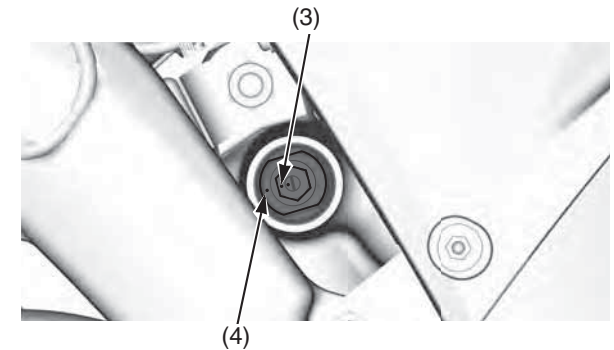

(3) high speed compression damping adjuster punch mark  
(4) adjuster body punch mark

# Rear Suspension Adjustments

## Low Speed Damping:

The low speed damping can be adjusted by turning the center screw of the compression damping adjuster.

The low speed compression damping adjuster has 13 clicks or more.

Turning the adjuster one full turn changes the adjuster 4 clicks.

To adjust to the standard position:

1. Turn the adjuster clockwise (harder) until it will no longer turn (lightly seat). Turn the adjuster counterclockwise (softer) until it clicks. This click is position 1.
2. (CRF450RX/RWE)  
Set the adjuster 10 clicks and adjust it until the punch mark (5) on the adjuster and the punch mark (4) on the adjuster body are aligned.  
(CRF450R)  
Set the adjuster 9 clicks and adjust it until the punch mark (5) on the adjuster and the punch mark (4) on the adjuster body are aligned.

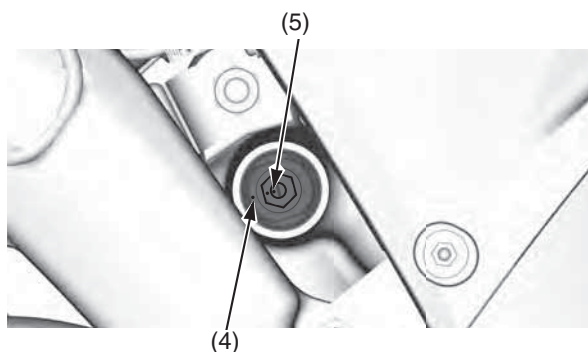

(4) adjuster body punch mark  
(5) low speed compression damping adjuster punch mark

## Rebound Damping

The rebound damping adjuster (6) is located at the lower end of the rear shock absorber.

It has 17 clicks or more. Turning the adjuster one full turn changes the adjuster 8 clicks.

- Rotate adjuster gently to prevent damage to the rear shock absorber.
- When adjusting the rebound damping adjuster, make sure to use the proper size tool to avoid damage.
- Rebound damping can be increased by turning the adjuster clockwise.
- Be sure that the rebound adjuster is firmly located in a detent, and not between positions.

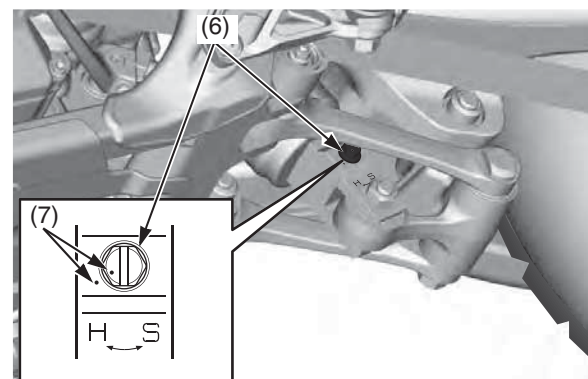

(6) rebound damping adjuster (7) punch marks

To adjust to the standard position:

1. Turn the adjuster clockwise (harder) until it will no longer turn (lightly seat). Turn the adjuster counterclockwise (softer) until it clicks. This click is position 1.
2. (CRF450RX)  
Set the adjuster 8 to 11 clicks and adjust it until the punch marks (7) on the adjuster and the rear shock absorber are aligned.  
(CRF450R/RWE)  
Set the adjuster 6 to 9 clicks and adjust it until the punch marks (7) on the adjuster and the rear shock absorber are aligned.



## Rear Suspension Race Sag

Setting the proper race sag (ride height) is very important for competition use.

Race sag refers to the amount of rear wheel travel used by your CRF at rest, ready to ride, with you on the seat. As a general rule of thumb, the race sag dimension should be about one-third of the maximum travel.

On your CRF, ride height is changed by adjusting the rear suspension spring pre-load.

### Spring Pre-load & Race Sag Adjustment

The following adjustment procedure establishes the correct starting point for any suspension tuning — the proper rear suspension spring preload adjustment for your specific needs.

Your CRF should be at normal racing weight, including fuel, oil and coolant. You should be wearing all your normal protective apparel. You will need two helpers.

To calculate the proper adjustment, it is necessary to measure between two fixed points — from the center of the seat mounting bolt to the center of the chain adjuster lock nut as illustrated here — for two different situations:

*unloaded*: motorcycle on an optional workstand with rear suspension fully extended, no rider.

*loaded with rider*: motorcycle on ground, with rider.

1. Support your CRF on an optional workstand with the rear wheel off the ground.
2. Measure the *unloaded* dimension.

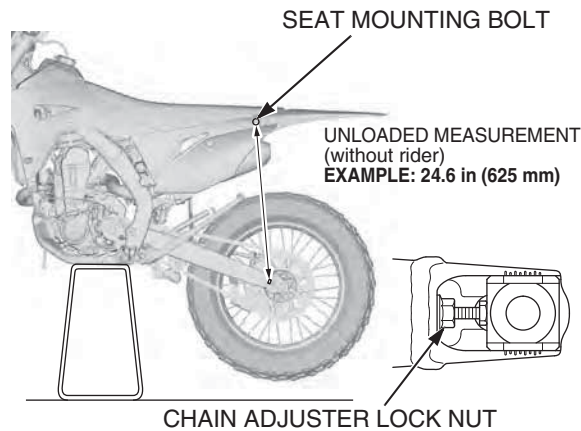

3. Measure the *loaded with rider* dimension. Remove the workstand. With two helpers available, sit as far forward as possible on your CRF's seat, wearing your riding apparel. Ask one helper to steady your CRF perfectly upright so you can put both feet on the pegs. Bounce your weight on the seat a couple of times to help the suspension overcome any situation and settle to a good reference point.

Ask the other helper to measure the *loaded with rider* dimension.

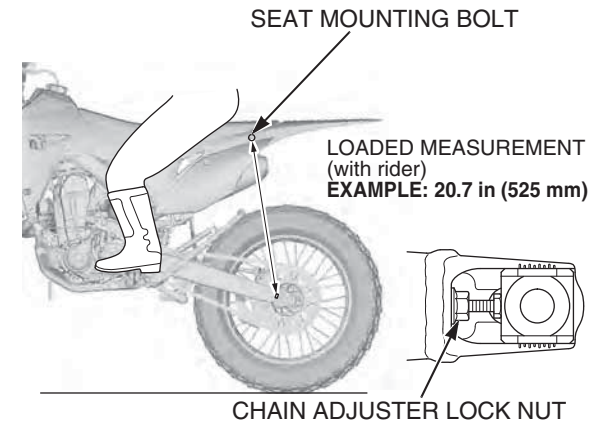

Example:

Unloaded = 24.6 in (625 mm)

– Loaded = 20.7 in (525 mm)

---

Race Sag = 3.9 in (100 mm)

4. Calculate the *race sag* dimension.

To do this, subtract the *loaded with rider* dimension (step 3) from the *unloaded* dimension (step 2).

Standard Race Sag: 4.1 in (105 mm)

Adjust spring pre-load as necessary to obtain the desired handling results.

Decreasing the race sag dimension (example: 3.7 in, 95 mm) improves turning ability for tight terrain at the cost of slightly reduced straight line stability.

Increasing the race sag dimension (example: 4.5 in, 115 mm) may improve stability on faster terrain with less turns, but will reduce turning performance slightly and may upset the balance between the front and rear suspension, producing a harsher ride. This will happen if the adjustment shifts the effective wheel travel toward the more progressive end of its range.



# Rear Suspension Adjustments

---

## Spring Rates

If you are lighter or heavier than the average rider and cannot set the proper ride height with altering the correct spring pre-load, consider an optional rear shock spring.

A spring that is too soft for your weight forces you to add excessive spring pre-load to get the right race sag and, as a result, the rear end of the motorcycle is raised. This can cause the rear wheel to unload too much in the air and top out as travel rebounds. The rear end may top out from light braking, or kick sideways over lips and square-edged terrain. It may even top-out when you dismount your CRF.

Because of the great absorption quality of the shock bumper rubber, it may be difficult for you to notice when your CRF's suspension is bottoming. Some riders may think the damping or perhaps the leverage ratio is too harsh. In reality, the problem is most likely insufficient spring pre-load or a spring that is too soft. Either situation prevents utilizing the full travel.

Keep in mind that a properly adjusted suspension system may bottom slightly every few minutes at full speed. Adjusting the suspension to avoid this occasional bottoming may cost more in overall suspension performance than it is worth.

A spring that is too stiff for your weight will not allow the rear tire to hook up under acceleration and will pass more bumps on to you.

# Suspension Adjustments for Track Conditions

---

## Soft Surface

On soft ground, sand, and especially mud, consider increasing compression damping front and rear.

Sand often requires a bit more rebound damping to minimize rear end kick. Although sand bumps are usually larger, there's more distance between them, giving the shock more time to recover.

You may want a little bit stiffer front suspension for sand tracks to help keep the front end up and improve straight-line stability.

In a muddy event, stiffer optional springs front and rear may help, especially if you are heavier than the average rider. Your CRF may be under-sprung because of the added weight of the clinging mud. This additional weight may compress the suspension too much and affect traction.

## Hard Surface

For a fast, hard track with no large jumps, you can probably run the same spring as normal, but run softer damping both ways-compression and rebound. If you run softer rebound damping, the wheel will follow the rough ground and small bumps much better, and you will hook up better. With a lot of rebound damping, the wheel returns very slowly and doesn't contact the ground quickly enough after each bump. The result is a loss of traction and slower lap times.

# Suspension Adjustment Guidelines

Follow the procedures described below to accurately adjust your CRF, using the methods described on pages 143 – 151. Remember to make all adjustments in one-click or 1/12 turn increments. Test ride after each adjustment.

## Front Suspension Adjustment Adjustments for Type of Track

Hard-surfaced track	Begin with the standard setting. If the suspension is too stiff/soft, adjust according to the chart below.
Sand track	Adjust to a stiffer position. Example: – Turn the compression damping adjuster to a stiffer position. – Install the optional stiff spring. (Adjust compression damping to a softer position and rebound damping to a stiffer position at this time.)
Mud track	Adjust to a stiffer position because mud build-up increases your CRF's weight. Example: – Turn the compression damping adjuster to a stiffer setting. – Install the optional stiff spring.

## Adjustments for Too Soft/Stiff Damping

	Symptom	Action
Soft suspension	Initial travel too soft: <ul style="list-style-type: none"> <li>• Steering is too quick.</li> <li>• Front end darts while cornering or riding in a straight line.</li> </ul>	<ul style="list-style-type: none"> <li>– Test stiffer compression damping adjustments in one-click increments.</li> <li>– Test stiffer rebound damping in one-click increments.</li> </ul>
	Middle travel too soft: <ul style="list-style-type: none"> <li>• Front end dives when cornering.</li> </ul>	If suspension isn't stiff in initial travel: <ul style="list-style-type: none"> <li>– Test stiffer compression damping adjustments in one-click increments.</li> </ul> If initial travel becomes stiff because of the above adjustment: <ul style="list-style-type: none"> <li>– Reduce the rebound damping in one-click increments.</li> <li>– Test softer compression damping adjustments in one-click increments.</li> </ul> If that doesn't solve the problem, install the optional stiff spring.
	Final travel too soft: <ul style="list-style-type: none"> <li>• Bottoms on landings.</li> <li>• Bottoms on large bumps, especially downhill bumps.</li> </ul>	If initial and middle travel aren't stiff: <ul style="list-style-type: none"> <li>– Test stiffer compression damping adjustments in one-click increments.</li> </ul> If initial and middle travel are stiff: <ul style="list-style-type: none"> <li>– Install the optional stiff spring.</li> </ul> If initial travel is stiff after installing the optional stiff spring: <ul style="list-style-type: none"> <li>– Test softer compression damping adjustments in one-click increments.</li> </ul> If initial travel is still soft after installing the optional stiff spring: <ul style="list-style-type: none"> <li>– Test stiffer compression damping adjustments in one-click increments.</li> </ul> If final travel is still soft after installing the optional stiff spring: <ul style="list-style-type: none"> <li>– Increase the fork oil capacity in increments of 0.2 US oz (5 cm<sup>3</sup>).</li> </ul>
	Entire travel too soft: <ul style="list-style-type: none"> <li>• Front end shakes.</li> <li>• Fork bottoms over any type of terrain.</li> </ul>	<ul style="list-style-type: none"> <li>– Install the optional stiff spring.</li> <li>– Test stiffer compression damping adjustments in one-click increments.</li> <li>– Increase rebound damping in one-click increments.</li> </ul>

# Suspension Adjustment Guidelines

	Symptom	Action
Stiff suspension	<p>Initial travel too stiff:</p> <ul style="list-style-type: none"> <li>• Stiff on small bumps while riding at full throttle in a straight line.</li> <li>• Stiff on small cornering bumps.</li> <li>• Front end wanders while riding at full throttle in a straight line.</li> </ul>	<ul style="list-style-type: none"> <li>– Test softer compression damping adjustments in one-click increments.</li> <li>– Reduce the rebound damping adjustments in one-click increments.</li> <li>– Check for dirt in the dust seals. Check the fork oil for any contamination. If the front end dives while cornering after the above adjustment: Reduce the rebound damping in one-click increments. If that doesn't solve the problem, install the optional stiff spring.</li> <li>– If the stiff spring makes the suspension too stiff over the full range of travel: test softer compression damping adjustments in one-click increments until the desired compression damping for initial travel is obtained.</li> </ul>
	<p>Middle travel too stiff:</p> <ul style="list-style-type: none"> <li>• Stiff on bumps when cornering.</li> <li>• Front end wanders when cornering.</li> <li>• Stiff suspension on bumps, especially downhill bumps.</li> <li>• While braking, front end dives during initial travel, then feels stiff.</li> </ul>	<p>If initial travel isn't stiff:</p> <ul style="list-style-type: none"> <li>– Test stiffer compression damping adjustments in one-click increments. (This should produce smooth fork action from initial to middle travel.)</li> </ul> <p>If initial and middle travel is stiff:</p> <ul style="list-style-type: none"> <li>– Test softer compression damping adjustments in one-click increments.</li> <li>– Reduce the rebound damping in one-click increments.</li> </ul>
	<p>Final travel too stiff:</p> <ul style="list-style-type: none"> <li>• Doesn't bottom on landings, but feels stiff.</li> <li>• Stiff on large bumps, especially downhill bumps.</li> <li>• Stiff on large bumps when cornering.</li> </ul>	<p>If initial and middle travel aren't stiff:</p> <ul style="list-style-type: none"> <li>– Test stiffer compression damping adjustments in one-click increments. (This should produce smooth fork action from initial to middle travel.)</li> </ul> <p>If final travel is still stiff after the above adjustment, or If initial and middle travel becomes stiff:</p> <ul style="list-style-type: none"> <li>– Install the optional soft spring.</li> <li>– Test softer compression damping adjustments in one-click increments.</li> </ul> <p>If the entire travel feels stiff after the above adjustment:</p> <ul style="list-style-type: none"> <li>– Test softer compression damping adjustments in one-click increments until the desired initial travel compression damping is obtained.</li> <li>– Lower the oil capacity by 0.2 US oz (5 cm<sup>3</sup>).</li> </ul>
	<p>Entire travel too stiff:</p> <ul style="list-style-type: none"> <li>• Stiff suspension on any type of terrain.</li> </ul>	<ul style="list-style-type: none"> <li>– Test softer compression damping adjustments in one-click increments.</li> <li>– Reduce the rebound damping in one-click increments.</li> <li>– Lower the oil capacity by 0.2 US oz (5 cm<sup>3</sup>).</li> </ul>

# Suspension Adjustment Guidelines

## Rear Suspension Adjustment Adjustments for Type of Track

Hard-surfaced track	Begin with the standard settings. If the suspension is too stiff/soft, adjust according to the chart below.
Sand track	Lower the rear end (to improve front wheel stability) by increasing Race Sag (reduce spring pre-load). Example: – Turn the compression damping adjuster and, especially, rebound damping adjuster to a stiffer setting. – Increase standard Race Sag (+0.2 to 0.4 in/5 to 10 mm).
Mud track	Adjust to a stiffer position because mud build-up increases your CRF's weight. Example: – Adjust the compression and rebound damping adjusters to stiffer settings. – Install an optional stiff spring. – Reduce standard Race Sag (–0.2 to –0.4 in/–5 to –10 mm).

## Symptoms and Adjustment

- Always begin with the standard settings.
- Turn the low speed compression and rebound adjusters in one-click increments, and the high speed compression adjuster in 1/12 turn increments at a time. Adjusting two or more clicks or turns at a time may cause you to pass over the best adjustment. Test ride after each adjustment.
- If, after setting, the suspension feels unusual, find the corresponding symptom in the table and test stiffer or softer compression and/or rebound damping adjustments until the correct settings are obtained as described.

	Symptom	Action
Stiff suspension	Suspension feels stiff on small bumps	1. Test softer low speed compression adjustment. 2. If it still feels stiff, further test softer low and high speed compression adjustments simultaneously.
	Suspension feels stiff on large bumps	1. Test softer high speed compression adjustment. 2. If it still feels stiff, further test softer low and high speed compression adjustments simultaneously.
	Entire travel too stiff	1. Test softer high and low speed compression adjustments and rebound adjustment simultaneously. 2. If it still feels stiff, replace the spring with an optional soft spring and begin with the standard settings to softer settings.
Soft suspension	Entire travel too soft	1. Test stiffer high and low speed compression adjustments simultaneously. 2. If it still feels soft, replace the spring with an optional stiff spring and begin with the standard settings to stiffer setting.
	Rear end sways	1. Test stiffer high and low speed compression adjustments and rebound adjustment to stiffer settings simultaneously.
Suspension bottoms	Suspension bottoms at landing after jumping	1. Test stiffer high speed compression adjustment. 2. If it still bottoms, test stiffer high and low speed compression adjustments, and replace the spring with a stiff spring (optional) if necessary.
	Suspension bottoms after landing	1. Test stiffer low speed compression adjustment. 2. If it still bottoms, test stiffer high and low speed compression adjustments, and replace the spring with a stiff spring (optional) if necessary.
	Suspension bottoms after end of continuous bumps	1. Test softer rebound damping adjustment. 2. If it still bottoms, test stiffer high and low speed compression adjustments and softer rebound damping adjustment, and replace the spring with an optional stiff spring if necessary.



## Spark Plug Reading

Refer to *Spark Plug* on page 78.

The following procedure is recommended. You may not get an accurate reading if you simply turn off the engine and pull the plug for inspection.

Use a new spark plug. Inspect the plug before installing it.

### NOTICE

*Using spark plugs with an improper heat range or incorrect reach can cause engine damage.*

Ride for 10 – 15 minutes before taking a plug reading. A new plug will not color immediately.

Before removing the spark plug, clean the spark plug area thoroughly to prevent dirt from entering the cylinder.

To obtain an accurate reading of a new spark plug:

1. Accelerate at full throttle on a straight.
2. Depress and hold the engine stop button and pull the clutch lever in.
3. Coast to a stop.
4. Remove the spark plug.
5. Use a magnifying glass to inspect the spark plug. The porcelain insulator (1) around the center electrode (2) should appear clean and colorless with a gray ring around the center electrode where it exits the porcelain. Light gray or white color streaks the porcelain insulator and center electrode indicate lean air-fuel mixture. Wet or black sooty streaks on the porcelain indicate rich air-fuel mixture.

### NOTICE

*An improperly tightened spark plug can damage the engine. If a plug is too loose, the piston may be damaged. If a plug is too tight, the threads may be damaged.*

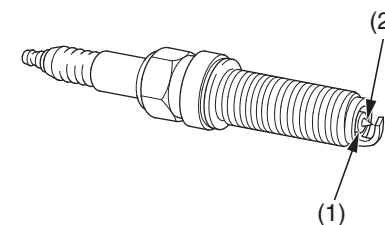

(1) porcelain insulator      (2) center electrode

### Spark Plug Coloring Guidelines

Condition	Spark Plug Appearance	Mixture
Normal	Dark brown to light tan color with dry electrode	correct
Overheating (Lean)	Light gray or white color	lean
Wet (Rich)	Wet or sooty	rich

Remember that in addition to improper air-fuel mixture:

- A lean condition can be caused by air leaks in the inlet tract or exhaust system, the passage of too much air because of the use of the wrong air cleaner, or use of a less-restrictive aftermarket exhaust system.
- A rich condition can be caused by a plugged or dirty air cleaner, use of a more-restrictive aftermarket exhaust system, or excessive oil on the air cleaner.  
Excessive smoking will occur.

# Chassis Adjustments

The following suggestions may improve a specific concern. Subtle changes in overall handling may also be noted.

## Rear End

If you have a problem with rear wheel traction, raise the rear end of your CRF by increasing the rear suspension spring pre-load. Instead of running 3.9 in (100 mm) of sag, you can run 3.5 in (90 mm) so the rear of the motorcycle will sit a little higher. This should produce more traction because of the change to the swingarm and location of your CRF's center of gravity.

If you have a problem with the steering head shaking when you use the front brake hard or if your CRF wants to turn too quickly, lower the rear of the motorcycle by reducing the rear suspension spring pre-load. This will increase fork rake and trail and should improve stability in a straight line. The effective suspension travel will be transferred toward the firmer end of wheel travel.

Keep the race sag adjustment (page 149) in the 3.7 – 4.5 in (95 – 115 mm) range.

## Fork Height/Angle

The position of the fork in the clamp is not adjustable.

### Standard Position

The groove (1) in the outer tube is aligned with the top surface of the upper fork bridge (2).

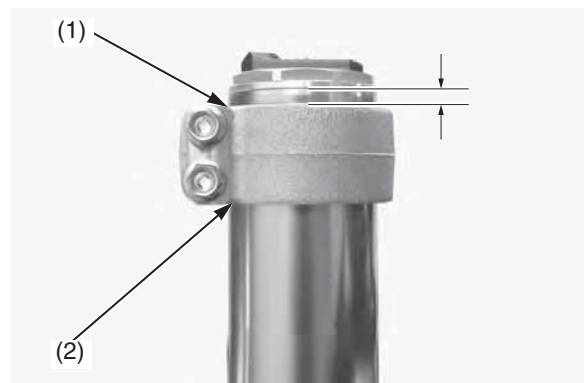

(1) groove  
(2) upper fork bridge

## Wheelbase

Adjusting your CRF's wheelbase can offer subtle changes in overall handling. You may adjust wheelbase by adding or removing links on the drive chain. If you change the wheelbase, be sure to recheck race sag and adjust, if necessary.

In the past, a general rule was lengthen the wheelbase to add straight line stability, shorten the wheelbase to improve turning. However, we suggest you do not lengthen the wheelbase of your CRF unless you are racing on a track with more fast sections than normal.

As a general recommendation, keep the wheelbase as short as possible. This positions the wheels closer together, improves turning response, increases weighting (traction) on the rear wheel, and lightens weighting on the front wheel.

With your CRF, you will probably find that the standard setting or a shorter wheelbase will offer more overall benefits.

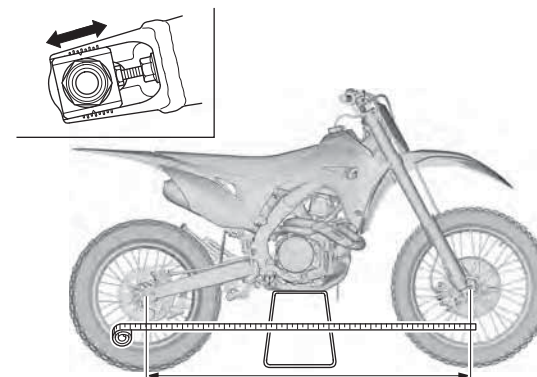

You can “adjust” the power delivery of the standard engine to suit track conditions by changing gearing. This allows you to utilize a different portion of the engine’s power range at a given throttle setting. New gearing may provide the change you are looking for without the need to consider further modifications.

The portion of your engine’s power range you use can be adjusted by changing the final drive ratio with different sized driven sprockets. Gearing changes allow you to more closely match the type of terrain and the available traction.

Normally, a change of one tooth on the driven sprocket will be sufficient.

There is a choice of both higher and lower final drive ratios with two optional driven sprockets. Like the optional springs, these sprockets are listed in the Optional Parts List section of this manual (page 181).

Unless you have the required mechanical know-how, tools, and an official Honda Service Manual, sprocket changing should be done by your dealer.

### Higher Gearing (less driven sprocket teeth)

- increases top speed in each gear (provided the engine will pull the higher gearing)
- reduces frequency of shifting (wider gear ratios)
- reduces engine rpm at a given throttle setting or ground speed (which may allow better rear wheel traction on slippery or loose terrain)

However:

- the engine may not pull the higher gearing
- the spacing between gears may be too wide
- engine rpm may be too low

### Lower Gearing (more driven sprocket teeth)

- decreases top speed in each gear
- increases frequency of shifting (narrower gear ratios)
- increases engine rpm at a given throttle setting or ground speed (which may provide more power-to-the-ground on good traction surfaces)

However:

- spacing between gears may be too narrow
- engine rpm may be too high

Some tracks may be watered heavily prior to the first race (CRF450RX)/moto (CRF450R/RWE), then lightly or not at all during the day. This results in a track surface that is slippery during the first few races (CRF450RX)/mos (CRF450R/RWE), then changes from good to great and back to good and possibly ends the day with a slick rock-hard consistency.

Ideally, your gearing should be adjusted to suit all these conditions.

- Wet and slippery or sandy conditions: use a higher gear (less teeth) to keep engine rpm down, and avoid unwanted wheelspin. The engine may bog in certain corners so you’ll need to slip the clutch to compensate; downshifting may be too drastic a change in speed.
- Average conditions: use the standard sprocket.
- Hard (but not slippery) track conditions: use lower gearing (more teeth) to keep the engine rpm high where the engine produces the most power. This may require an extra upshift on certain sections or perhaps you can just rev it out a bit longer.

For tight tracks, consider lower gearing to avoid having to slip the clutch frequently. Repeated fanning or pulling of the clutch lever in a turn to raise engine rpm may eventually damage the clutch system.

A gearing change may help for riding in sand, where you want to keep the front end light so it can float from the peak of one sand whoop to the next. Generally, with higher gearing, it is easier to maintain that perfect attitude (maximum rear wheel traction and a light front end) because you remain in the powerband longer in each gear. The higher gearing allows you to steer more efficiently with throttle control and body English.

If you are riding a track with sections where you choose to over-rev the engine temporarily rather than shifting up, higher gearing might help.

Sometimes you have to sacrifice performance on one section of the track to gain a better overall time. Your goal is the fastest overall lap time, even if the cost is some sections where the gearing feels wrong.

If you decide to try a gearing change, have someone check your times with a stopwatch (before and after the change) to get an accurate appraisal of the change. “Seat-of-the-pants” feelings can’t be trusted. Eliminating wheelspin with a gearing change can make you feel like you’re going slower when, in reality, you’ve decreased your time by increasing your speed with better traction.

These gearing recommendations should be evaluated by considering your ability, your riding style, and the track.

## Tire Selection for Track Conditions

---

Choosing the correct tire tread pattern and rubber compound can affect your placing in competition. The tires on your CRF offer a “happy medium” for the variety of soil conditions the majority of riders are likely to encounter.

Experienced competitors often switch to tires developed for specific terrain conditions. If you do switch, stay with the factory recommended sizes. Other tires may affect handling or acceleration.

Be aware that tire sizes (width and aspect ratio) do vary from manufacturer to manufacturer or even among tires made by the same manufacturer. Variations in tires, especially the sidewall profile, can change the attitude of your CRF and its handling. Tire variations that raise or lower the rear of your CRF have a more significant effect on handling than variations in front tires which, generally, don’t vary as much. Often, you can see or feel the change in tire size. Another way to check is to measure the rolling circumference of the old and new tires. A higher profile tire will have a larger rolling circumference.

If you do switch to tires designed for special terrain use, remember they will be less acceptable in other circumstances. For example, an aggressive mud tire will give excellent grip on wet, loamy terrain, but less impressive grip on a hard surface.

If you choose a tire with a sticky compound for added traction, remember that it may transfer additional loads to the transmission because it grips so well, especially when riding in situations that normally place unusual demands on the transmission.

Complete consumer information can be obtained from the various tire manufacturer representatives and dealers.

Some general recommendations for specific terrain follow:

### Hard, Slick Soil

Use tires with many relatively short knobs that are close together in order to obtain the largest possible contact patch on the surface. The rubber compound needs to be softer for hard ground in order to hook up, but not so soft that the knobs roll over easily and affect holding a straight line. These tires tend to wear more quickly than standard tires because of the combination of soft rubber and hard terrain.

### Muddy Soil

Use a more open tread pattern to avoid clogging. For these conditions, the relatively long knobs will probably be made from a harder rubber compound to reduce any tendency to bend back under acceleration or wear quickly.

### Loose, Sandy Soil

Use a tire that is similar in construction to those needed for tacky soil and mud, but with a few more knobs.

The following suggestions may make your ride both more comfortable and more responsive to your control input.

## Control Positioning

- Position the control levers so that you can use them comfortably when seated and standing.
- Adjust the mounting bolt (1) torque of the clutch and front brake lever assemblies so that they can rotate on the handlebar in a fall. If an assembly does not rotate, it may bend or break a control lever. Make sure that the bolts are torqued securely enough to prevent slippage during normal operation.

Apply Pro Honda Hondalock or an equivalent to the threads of these bolts prior to adjustment to help ensure the correct torque is retained. Tighten the top bolts first.

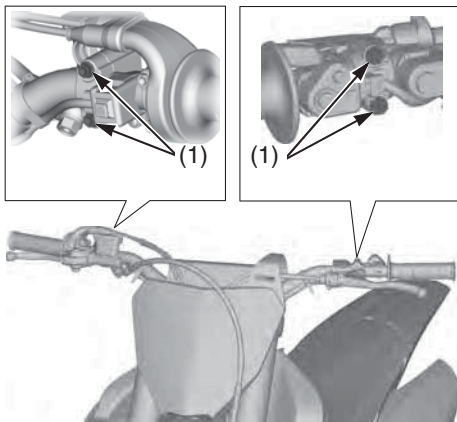

(1) control lever mounting bolts

As an alternative, consider wrapping the handlebar area under the control assemblies with Teflon tape. Then tighten the assemblies to their normal torque. Upon impact, the fully-tightened assemblies should rotate on the Teflon tape.

- Position the shift lever and rear brake pedal so they are close to your boot for rapid access, but not so close that either is depressed when sitting or standing comfortably on your CRF.

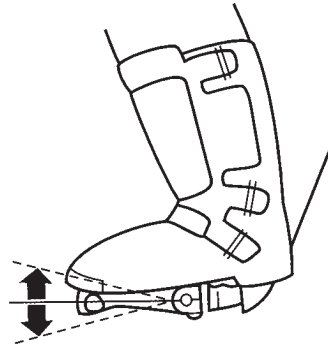

## Handlebar Position, Width & Shape

- Position the handlebar so that both gripping the bar and operating the controls are comfortable while both seated and standing, while riding straight ahead and turning.

Handlebar standard position

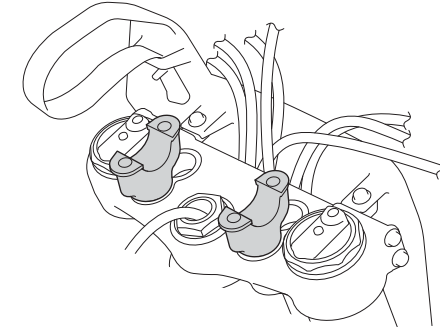

- The handlebar position may be moved backward 0.4 in (10 mm) by rotating the handlebar lower holders 180 degrees.
- The handlebar position may be moved forward 1 in (26 mm) by changing the position where the handlebar under holder bolts is inserted into the fork bridge holes.



# Personal Fit Adjustments

Position chart

Handlebar position	Handlebar lower holders position	Handlebar lower holders
Forward 1 in (26 mm)	Front holes of fork bridge	No change
Forward 0.6 in (16 mm)	Front holes of fork bridge	Rotating 180 degrees
Standard	Rear holes of fork bridge	No change
Backward 0.4 in (10 mm)	Rear holes of fork bridge	Rotating 180 degrees

Refer to an official Honda Service Manual for installation instructions. Be sure to check control cable and wiring harness routing after the adjustment.

- Handlebar width can be trimmed with a hacksaw to better suit your particular shoulder width and riding preference. Think this through carefully and cut off just a small amount at a time from both sides equally. It is obviously much easier to make the handlebar narrower than it is to add material.

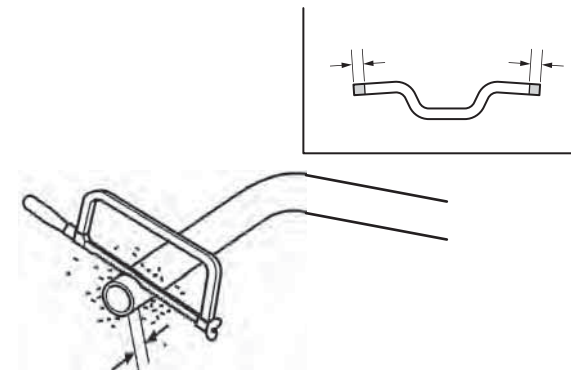

- Chamfer the edges to remove burrs and other irregularities or roughness after sawing the handlebar.
- An alternate handlebar shape, through varying rise or rearward sweep dimensions, will provide further adjustment to riding position and may better suit your particular body size or riding style. Each of the ergonomic dimensions of the machine was determined to suit the greatest possible number of riders based on an average size rider.

Here's helpful advice on how to transport and store your CRF, as well as three troubleshooting flow charts.

Transporting Your Motorcycle .....	162
Storing Your Honda.....	163
Preparation for Storage .....	163
Removal from Storage .....	163
You & the Environment.....	164
Troubleshooting .....	165

## Transporting Your Motorcycle

---

If you use a truck or motorcycle trailer to transport your CRF, we recommend that you follow these guidelines:

- Use a loading ramp.
- Relieve the fuel pressure (pages 43, 53) and drain the fuel from the fuel tank into an approved gasoline container.
- Secure the motorcycle in an upright position, using motorcycle tie-down straps. Avoid using rope, which can loosen and allow the motorcycle to fall over.

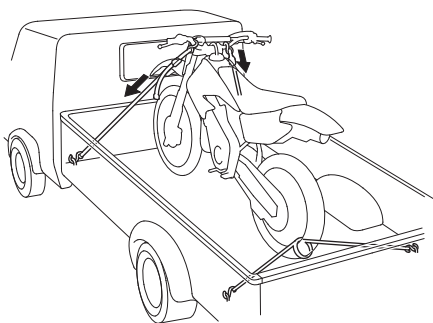

To secure your CRF, brace the front wheel against the front of the truck bed or trailer rail.

Attach the lower ends of two straps to the tie-down hooks on truck bed or trailer rail. Attach the upper ends of the straps to the handlebar (one on the right side, the other on the left), close to the fork.

Check that the tie-down straps do not contact any control cables or electrical wiring.

Tighten both straps until the front suspension is compressed about half-way. Too much pressure is unnecessary and could damage the fork seals.

Use another tie-down strap to keep the rear of the motorcycle from moving.

We recommend that you do not transport your CRF on its side. This can damage the motorcycle, and leaking gasoline could be a hazard.

If you won't be riding for an extended period, such as during the winter, thoroughly inspect your CRF and correct any problem before storing it. That way, needed repairs won't be forgotten and it will be easier to get your CRF running again.

To reduce or prevent deterioration that can occur during storage, also follow the following procedures.

## Preparation for Storage

1. Completely clean all parts of your CRF. If your CRF has been exposed to sea air or salt water, wash it down with fresh water and wipe dry.
2. Remove the engine guard A bolts/washers (1), B bolt/washer (2) and engine guard (3).
3. Change the engine oil and filter (page 63).

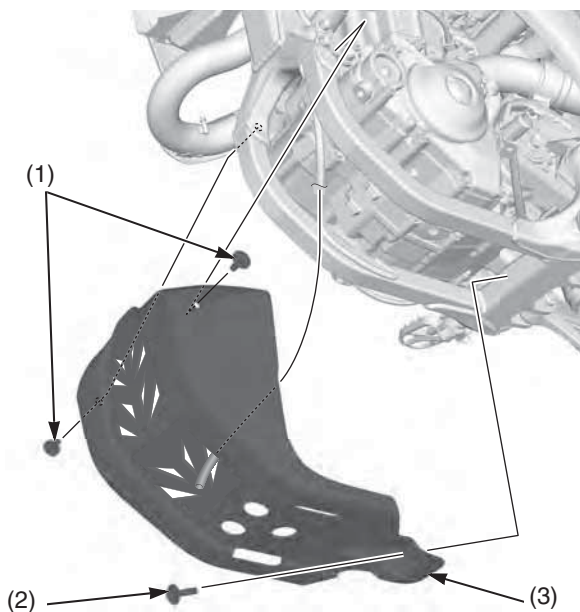

- (1) engine guard A bolts/washers  
 (2) engine guard B bolt/washer  
 (3) engine guard

4. Remove the radiator cap and coolant drain bolt (4) and sealing washer (5) at the water pump cover (6) to drain coolant. After the coolant has been completely drained, reinstall the drain bolt with a new sealing washer and radiator cap. Tighten the drain bolt to the specified torque: 7 lbf-ft (10 N·m, 1.0 kgf-m)

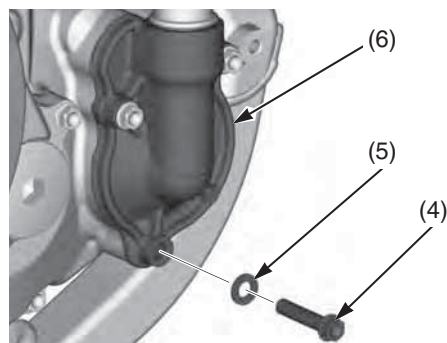

- (4) coolant drain bolt  
 (5) sealing washer (new)  
 (6) water pump cover

5. Install the engine guard (3), then tighten the engine guard A bolts/washers (1), B bolt/washer (2) to the specified torque: 7 lbf-ft (10 N·m, 1.0 kgf-m)
6. Lubricate the drive chain.
7. Relieve the fuel pressure (pages 43, 53) and drain the fuel from the fuel tank into an approved gasoline container.
8. Remove the battery. Store in an area protected from freezing temperatures and direct sunlight. Slow charge the battery (page 135) once a month.
9. Inflate the tires to their recommended pressures.
10. Place your CRF on an optional workstand or equivalent to raise both tires off the ground.

11. Stuff a rag into the muffler outlet. Then tie a plastic bag over the end of the muffler to prevent moisture from entering.
12. Store your CRF in an unheated area, free of dampness, away from sunlight, with a minimum of daily temperature variation.
13. Cover your CRF with a porous material. Avoid using plastic or similar non-breathing, coated materials that restrict air flow and allow heat and moisture to accumulate.

## Removal from Storage

1. Uncover and clean your CRF. Change the engine oil if more than 4 months have passed since the start of storage.
2. Uncover the end of the muffler and remove the rag from the muffler outlet.
3. Fill the fuel tank with the recommended fuel (pages 42, 52).
4. Charge the battery (page 135) as required. Install the battery.
5. Pour a fresh recommended coolant mixture slowly into the radiator fill hole up to the filler neck (page 65).  
 Capacity:  
 (CRF450RX)  
 1.22 US qt (1.15 ℓ) after disassembly  
 1.13 US qt (1.07 ℓ) after draining  
 (CRF450R/RWE)  
 1.19 US qt (1.13 ℓ) after disassembly  
 1.13 US qt (1.07 ℓ) after draining  
 Lean your CRF slightly right and left several times to bleed trapped air in the cooling system. If the coolant level lowers, add coolant and repeat the above procedure. Install the radiator cap securely.
6. Increase the fuel pressure (page 51).
7. Perform all maintenance checks (page 13).

## You & the Environment

---

Owning and riding a motorcycle can be enjoyable, but you must do your part to protect nature. When you show respect for the land, wildlife, and other people, you also help preserve the sport of off-road riding.

Following are tips on how you can be an environmentally responsible motorcycle owner.

- **Choose Sensible Cleaners.** Use a biodegradable detergent when you wash your CRF. Avoid aerosol spray cleaners that contain chlorofluorocarbons (CFCs) which damage the atmosphere's protective ozone layer. Don't throw cleaning solvents away; see the following guidelines for proper disposal.
- **Recycle Wastes.** It's illegal and thoughtless to put used engine oil in the trash, down a drain, or on the ground. Used oil, gasoline, coolant, and cleaning solvents contain poisons that can hurt refuse workers and contaminate our drinking water, lakes, rivers, and oceans. Before changing your oil, make sure you have the proper containers. Put oil and other toxic wastes in separate sealed containers and take them to a recycling center. Call your local or state office of public works or environmental services to find a recycling center in your area and get instructions on how to dispose of non-recyclable wastes.

### NOTICE

*Improper disposal of drained fluids is harmful to the environment.*



The items that are serviceable using this Manual are followed by the page number reference in parenthesis. The items that require use of the official Honda Service Manual are followed by an asterisk (\*).

## ENGINE DOES NOT START OR IS HARD TO START

Operate the start button with the throttle grip in fully closed position (page 17).

### CHECK

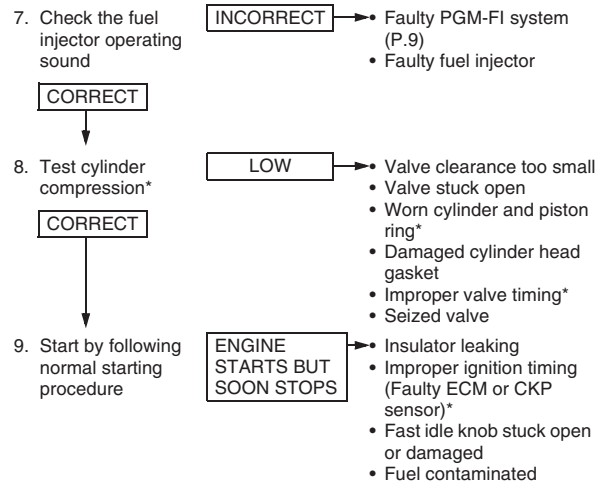
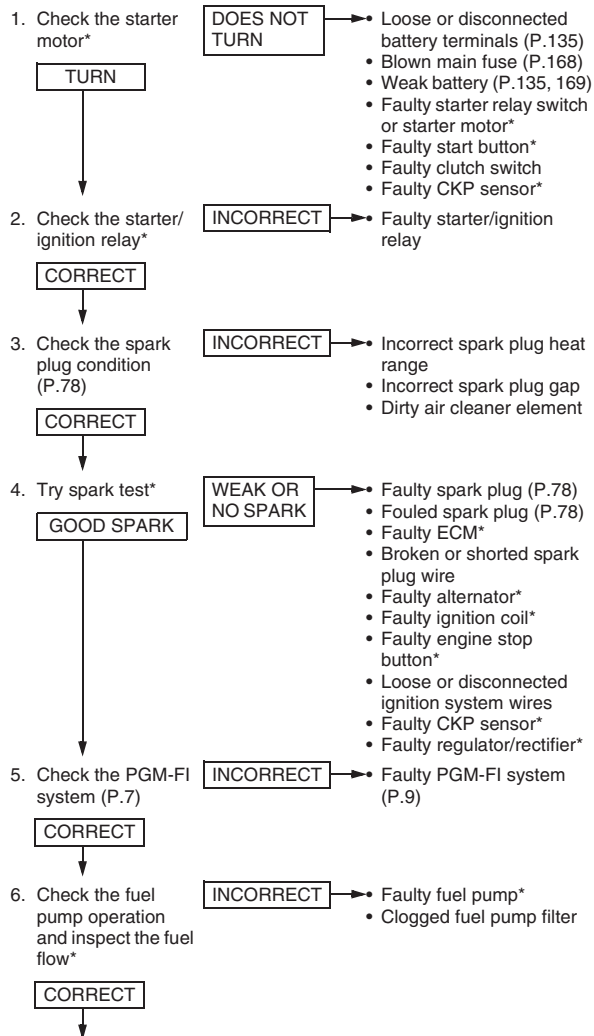

## ENGINE LACKS POWER

### CHECK

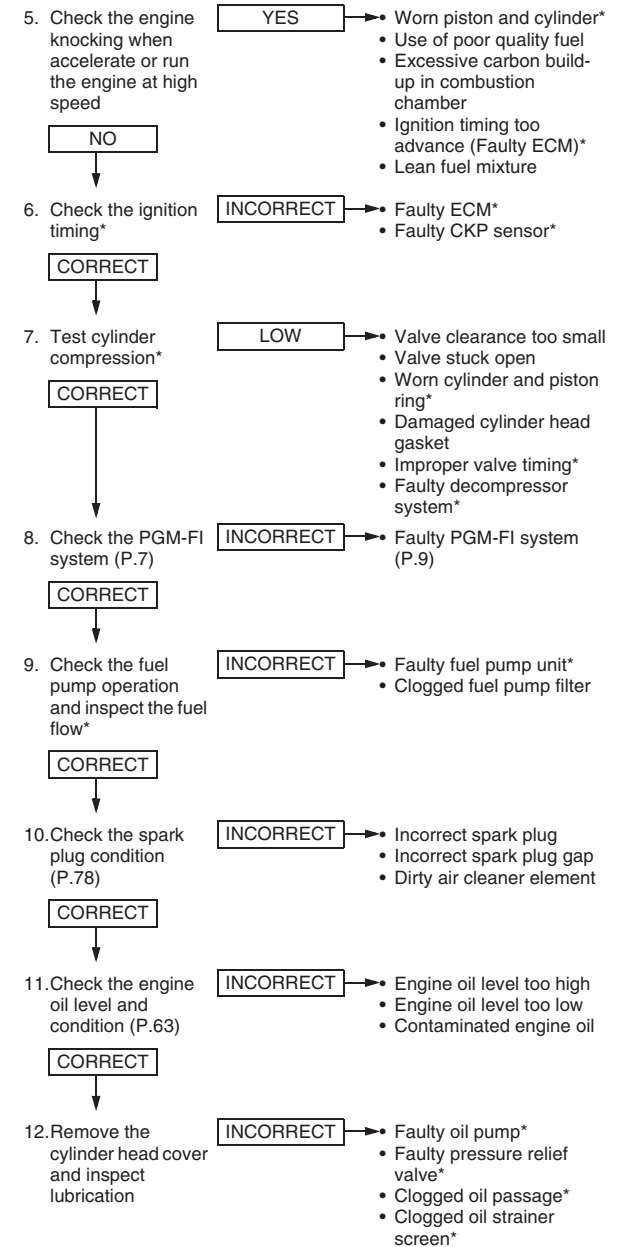
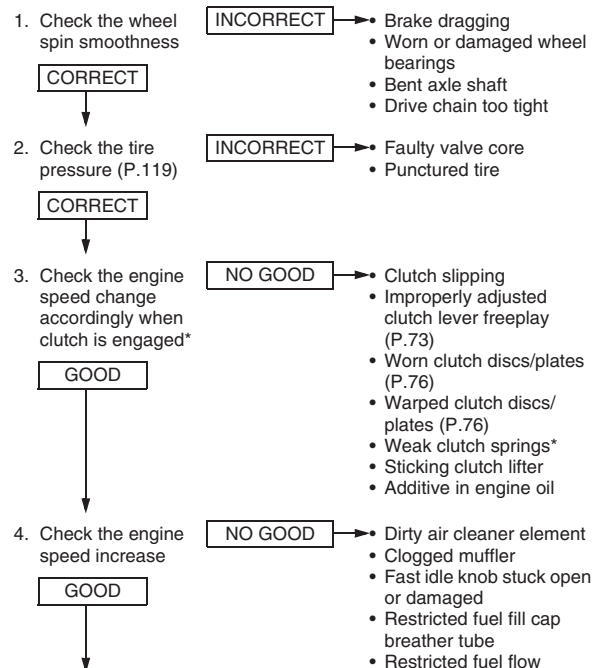

(cont'd)

# Troubleshooting

## POOR PERFORMANCE AT LOW AND IDLE SPEED

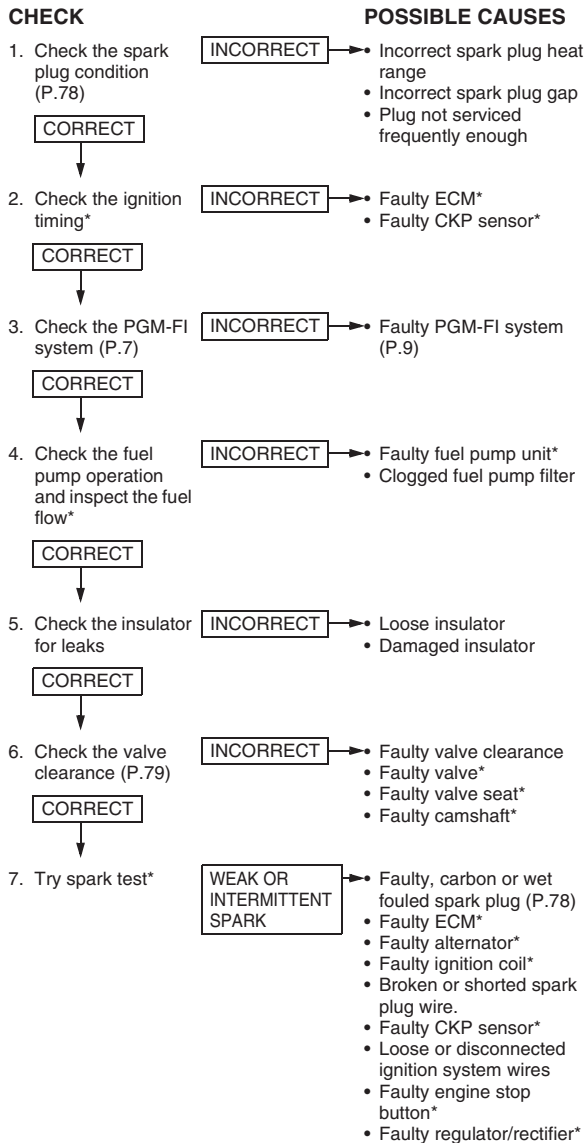

## POOR PERFORMANCE AT HIGH SPEED

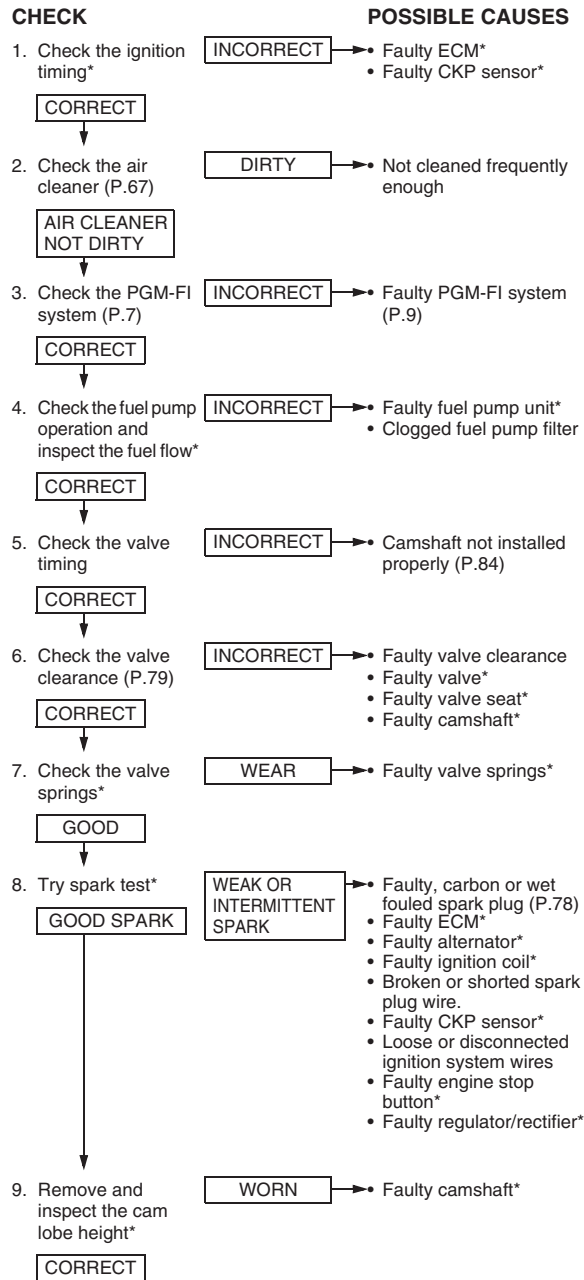

## POOR HANDLING

Steering is heavy

- Steering stem adjusting nut too tight\*
- Damaged steering head bearings

Either wheel is wobbling

- Excessive wheel bearing play
- Bent rim
- Improperly installed wheel hub
- Excessively worn swingarm pivot bearings
- Bent frame

The motorcycle pulls to one side

- Front and rear wheels not aligned
- Bent fork
- Bent swingarm
- Bent axle shaft
- Bent frame

This section gives practical advice to help you solve problems.

If a Fuse Blows .....	168
If Your Battery Is Low (or Dead) .....	169

## If a Fuse Blows

All of the electrical circuits on your CRF have a fuse to protect them from damage caused by excess current flow (short circuit or overload).

If something electrical on your CRF stops working, the first thing you should check for is a blown fuse. Check the fuse before looking elsewhere for another possible cause of the problem. Replace a blown fuse and check component operation.

- The main fuse (and spare) are located on the starter magnetic switch behind the right side cover.

### Recommended Main Fuse: 10A

1. To prevent an accidental short circuit, stop the engine.
2. Remove the seat (page 34).
3. Disconnect the negative (–) terminal (page 134).
4. Remove the right side cover and right air cleaner housing cover (page 126).

5. Remove the start magnetic switch stay bolt (1) and plastic wire band (2).
6. Pull out the start magnetic switch (3).
7. Remove the start magnetic switch cover (4).
8. Pull out the main fuse (5). If it is blown (6), install the spare main fuse (7).

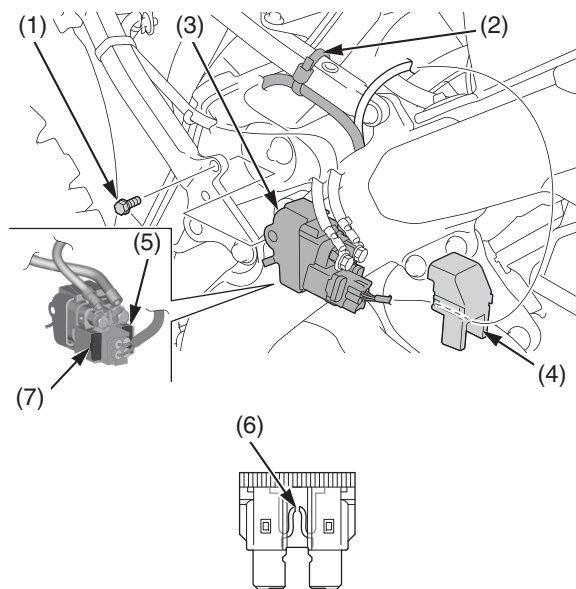

- (1) start magnetic switch stay bolt
- (2) wire band
- (3) start magnetic switch
- (4) start magnetic switch cover
- (5) main fuse
- (6) blown fuse
- (7) spare main fuse

9. Install the start magnetic switch cover (4).
10. Install the start magnetic switch (3).  
Install and tighten the start magnetic switch stay bolt (1) to the specified torque:  
**9 lbf·ft (12 N·m, 1.2 kgf·m)**
11. Install the plastic wire band (2).
12. Connect the negative (–) terminal (page 135).

If you do not have a replacement fuse with the proper rating for the circuit, install one with a lower rating.

### NOTICE

*Replacing a fuse with one that has a higher rating greatly increases the chance of damage to the electrical system.*

If you replace a blown fuse with a spare fuse that has a lower rating, replace the fuse with the correct rating as soon as you can. Also remember to replace the spare fuse that was installed.

If the replacement fuse of the same rating burns out in a short time, there is probably a serious electrical problem on your CRF.

Leave the blown fuse in that circuit and have your CRF checked by your dealer.

13. Install the right side cover, right air cleaner housing cover and bolts.
14. Install the seat (page 34).

## If Your Battery Is Low (or Dead)

---

If an overvoltage, overcurrent, or short circuit is applied, the battery fuse may blow.

Do not jump-start as this can damage your CRF's electrical system and battery.

Bump starting is not recommended.

Check the battery voltage using a digital multi meter with the cable connected.

Below 1V: The battery has failed; replace the battery.

Between 1V and 8V: The battery may have failed; charge the battery using a li-ion battery charger and then recheck, see page 135 Battery Charging. If you can't charge the battery or it appears unable to hold a charge, see your dealer.



BLANK PAGE

This section contains dimensions, capacities, and other technical data.

Vehicle Identification.....	172
Serial Numbers .....	172
Specifications .....	173
Torque Specifications .....	175
Nuts, Bolts, Fasteners .....	175
Oxygenated Fuels.....	178
Competition Logbook .....	179
Optional Parts List .....	181
Spare Parts & Equipment.....	182
Spare Parts .....	182
General Tools.....	182
Honda Special Tools .....	182
Chemical Products .....	182
Other Products .....	182
Wiring Diagram .....	183

# Vehicle Identification

## Serial Numbers

The VIN and engine serial number are required when you register your CRF. They may also be required when ordering replacement parts. You may record these numbers in the Quick Reference section at the rear of this manual.

The VIN (vehicle identification number) (1) is stamped on the right side of the steering head.

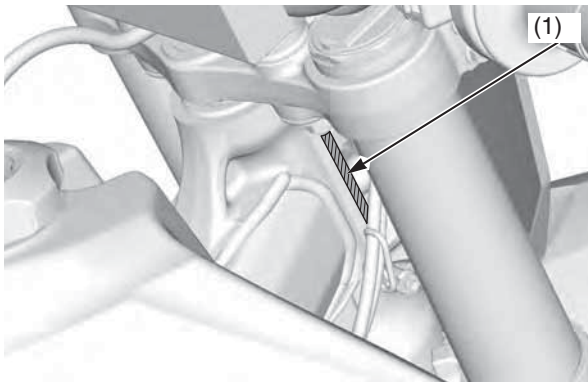

(1) VIN

The engine number (2) is stamped on the right crankcase.

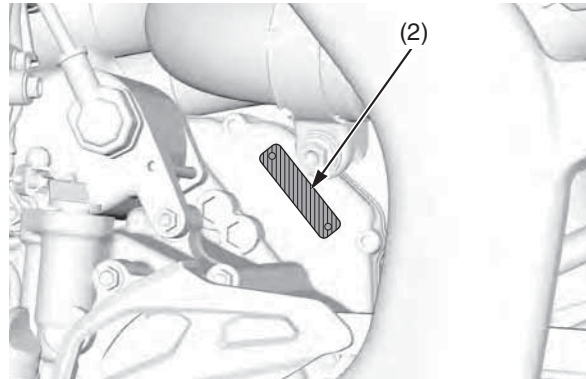

(2) engine number

# Specifications

Item	English	Metric
<b>Dimension</b>		
Overall length	CRF450RX: 85.6 in CRF450R/RWE: 85.9 in	CRF450RX: 2,175 mm CRF450R/RWE: 2,183 mm
Overall width	32.6 in	827 mm
Overall height	49.6 in	CRF450RX: 1,259 mm CRF450R/RWE: 1,260 mm
Wheelbase	CRF450RX: 58.1 in CRF450R/RWE: 58.3 in	CRF450RX: 1,477 mm CRF450R/RWE: 1,482 mm
Seat height	37.8 in	CRF450RX: 959 mm CRF450R/RWE: 960 mm
Footpeg height	CRF450RX: 16.4 in CRF450R/RWE: 16.5 in	CRF450RX: 417 mm CRF450R/RWE: 418 mm
Ground clearance	12.9 in	328 mm
<b>Frame</b>		
Type	Twin tube	
F. suspension	Telescopic fork, travel 10.55 in (268 mm) stroke 12.01 in (305 mm)	
R. suspension	Pro-link, CRF450RX: travel 12.28 in (312 mm) CRF450R/RWE: travel 12.36 in (314 mm)	
Tire size, front	CRF450RX: 90/90-21 54M CRF450R/RWE: 80/100-21 51M	
	DUNLOP	CRF450RX: AT81F CRF450R/RWE: MX3SF
Tire size, rear	CRF450RX: 120/90-18 65M CRF450R/RWE: 120/80-19 63M	
	DUNLOP	CRF450RX: AT81 CRF450R/RWE: MX3S
Tire type	bias-ply, tube	

Tire pressure, front (cold)	15 psi (100 kPa, 1.0 kgf/cm <sup>2</sup> )	
Tire pressure, rear (cold)	15 psi (100 kPa, 1.0 kgf/cm <sup>2</sup> )	
F. brake, swept area	Single disc brake 56.0 in <sup>2</sup> (361.0 cm <sup>2</sup> )	
R. brake, swept area	Single disc brake 60.5 in <sup>2</sup> (390.3 cm <sup>2</sup> )	
Fuel	unleaded gasoline, pump octane number of 91 or higher	
Fuel tank capacity	CRF450RX: 2.25 US gal	CRF450RX: 8.5 ℓ
	CRF450R/RWE: 1.66 US gal	CRF450R/RWE: 6.3 ℓ
Caster angle	CRF450RX: 27°26' CRF450R/RWE: 27°22'	
Trail length	4.6 in	116 mm
Fork oil capacity (except damper)	CRF450RX: 12.3 US oz	CRF450RX: 363 cm <sup>3</sup>
	CRF450R/RWE: 12.0 US oz	CRF450R/RWE: 356 cm <sup>3</sup>
Fork oil capacity (damper)	8.2 US oz	243 cm <sup>3</sup>

Item	English	Metric
<b>Engine</b>		
Type	Liquid cooled, 4-stroke	
Cylinder arrangement	Single 10° inclined from vertical	
Bore and stroke	3.7795 x 2.4464 in	96.000 x 62.138 mm
Displacement	27.436 cu-in	449.77 cm <sup>3</sup>
Compression ratio	13.5 : 1	
Valve clearance (cold)	Intake: 0.005 ± 0.001 in (0.13 ± 0.03 mm)	
	Exhaust: 0.011 ± 0.001 in (0.28 ± 0.03 mm)	
Engine oil capacity	after draining	1.06 US qt 1.00 ℓ
	after draining and oil filter change	1.10 US qt 1.04 ℓ
	after disassembly	1.43 US qt 1.35 ℓ
<b>Throttle body</b>		
Identification number	GQ2JA	
Idle speed	2,000 ± 100 rpm	
<b>Cooling system</b>		
Cooling capacity	after draining	
	1.13 US qt	1.07 ℓ
after disassembly	CRF450RX: 1.22 US qt	CRF450RX: 1.15 ℓ
	CRF450R/RWE: 1.19 US qt	CRF450R/RWE: 1.13 ℓ

(cont'd)

# Specifications

Item	English	Metric
<b>Drive train</b>		
Clutch type	Wet, multi-plate type	
Transmission	5-speed, constant mesh	
Primary reduction	2.357	
Gear ratio I	2.133	
Gear ratio II	1.706	
Gear ratio III	1.421	
Gear ratio IV	1.211	
Gear ratio V	1.043	
Final reduction	CRF450RX: 3.846 CRF450R/RWE: 3.769	
Gear shift pattern	Left foot-operated return system 1-N-2-3-4-5	
<b>Electrical</b>		
Battery	HY85S lithium-ion (li-ion) 12 V-2.0 Ah (20 HR)	
Ignition	ECM	
Starting system	Electric	
Spark plug	NGK	
Standard	SILMAR9A-9S	
For extended high speed riding	NGK SILMAR10A-9S	
Spark plug gap	0.031 – 0.035 in (0.8 – 0.9 mm)	
<b>Fuse</b>		
Main fuse	10 A	



## Nuts, Bolts, Fasteners

Check and tighten nuts, bolts, and fasteners before every outing.

### LEFT SIDE

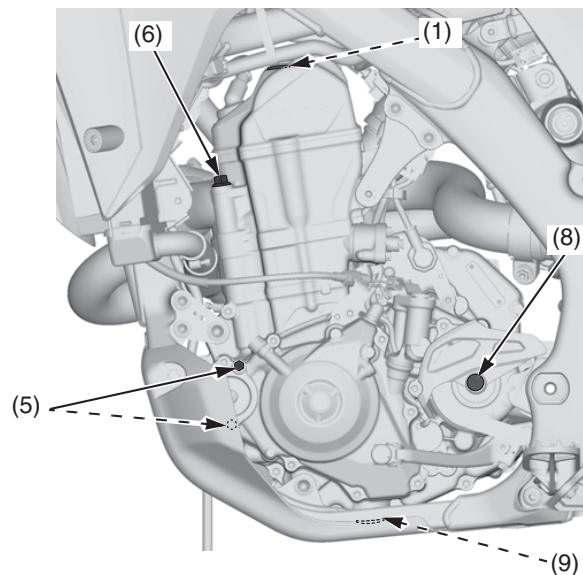

### RIGHT SIDE

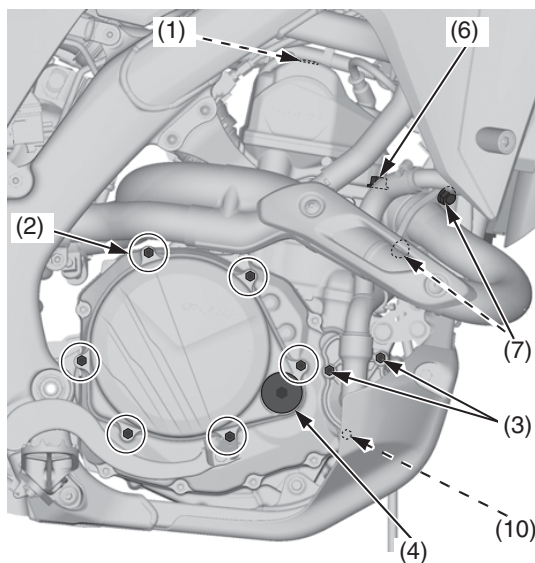

### ENGINE

Item	Torque			Remarks	
	lbf-ft	N-m	kgf-m		
1	Cylinder head cover socket bolts	7	10	1.0	
2	Clutch cover bolts	7	10	1.0	
3	Water pump cover bolts	7	10	1.0	
4	Crankshaft hole cap	11	15	1.5	NOTE 1
5	Oil filter cover bolts	7	10	1.0	
6	Cylinder head bolts	37	50	5.1	NOTE 2
7	Exhaust pipe joint nuts	15	20	2.0	
8	Drive sprocket bolt	23	31	3.2	
9	Engine oil drain bolt	13	18	1.8	NOTE 2
10	Coolant drain bolt	7	10	1.0	

NOTES: 1. Apply grease to the threads.

2. Apply engine oil to the threads and seating surface.

(cont'd)

# Torque Specifications

## LEFT SIDE

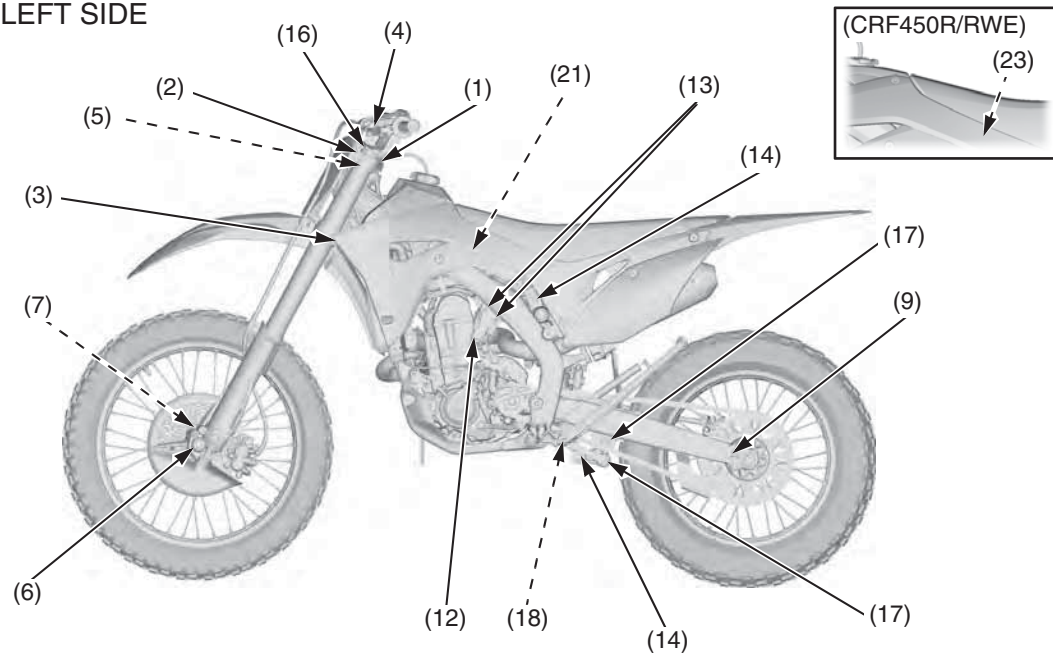

## RIGHT SIDE

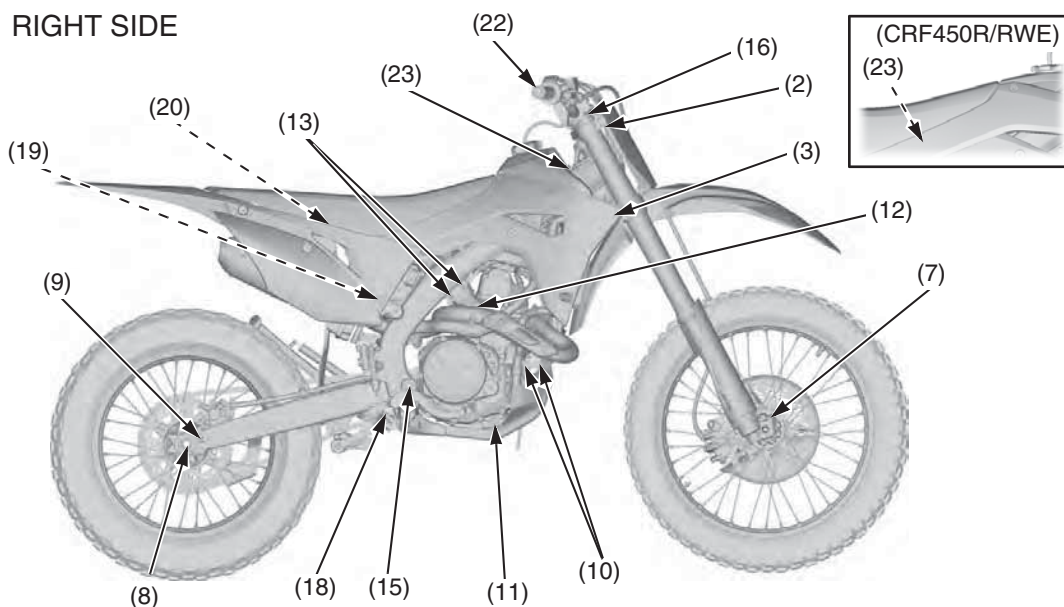

## FRAME

	Item	Torque			Remarks
		lb-ft	N-m	kgf-m	
1	Steering stem nut	80	108	11.0	
2	Fork bridge upper pinch bolts	16	22	2.2	
3	Fork bridge lower pinch bolts	15	20	2.0	
4	Handlebar upper holder bolts	16	22	2.2	
5	Handlebar lower holder nuts	32	44	4.5	NOTE 1
6	Front axle nut	65	88	9.0	
7	Axle pinch bolts	15	20	2.0	
8	Rear axle nut	94	128	13.1	NOTE 1
9	Chain adjuster lock nuts	20	27	2.8	NOTE 2
10	Front engine hanger nuts	40	54	5.5	
	Front engine hanger plate nuts	19	26	2.7	
11	Lower engine hanger nut	40	54	5.5	
12	Cylinder head hanger bolts	40	54	5.5	
13	Cylinder head hanger plate bolts	24	32	3.3	
14	Rear suspension (upper)	32	44	4.5	NOTE 1
	(lower)	32	44	4.5	NOTE 1
15	Swingarm pivot nut	65	88	9.0	NOTE 1
16	Fork				
	(fork damper assembly)	56	76	7.7	
	(fork bolt assembly)	22	30	3.1	
17	Rear shock arm nuts				
	(swingarm side)	38	52	5.3	NOTE 1, 5
	(shock link side)	38	52	5.3	NOTE 1, 5
18	Rear shock link bolts	27	37	3.8	NOTE 1, 5
19	Rear shock spring lock nut	32	44	4.5	
20	Battery terminal bolts	1.5	2.0	0.2	
21	Fuel pump mounting bolts (CRF450RX)	8	11	1.1	
	Fuel pump mounting nuts/cap nut (CRF450R/RWE)				
22	Front brake master cylinder holder bolts	7.3	9.9	1.0	
23	Fuel tank bolt (CRF450RX)	7	10	1.0	
	Fuel tank bolts (CRF450R/RWE)				

NOTES: 1. U-nut  
 2. UBS nut  
 5. Apply molybdenum oil to the threads and flange surface.

# Torque Specifications

## LEFT SIDE

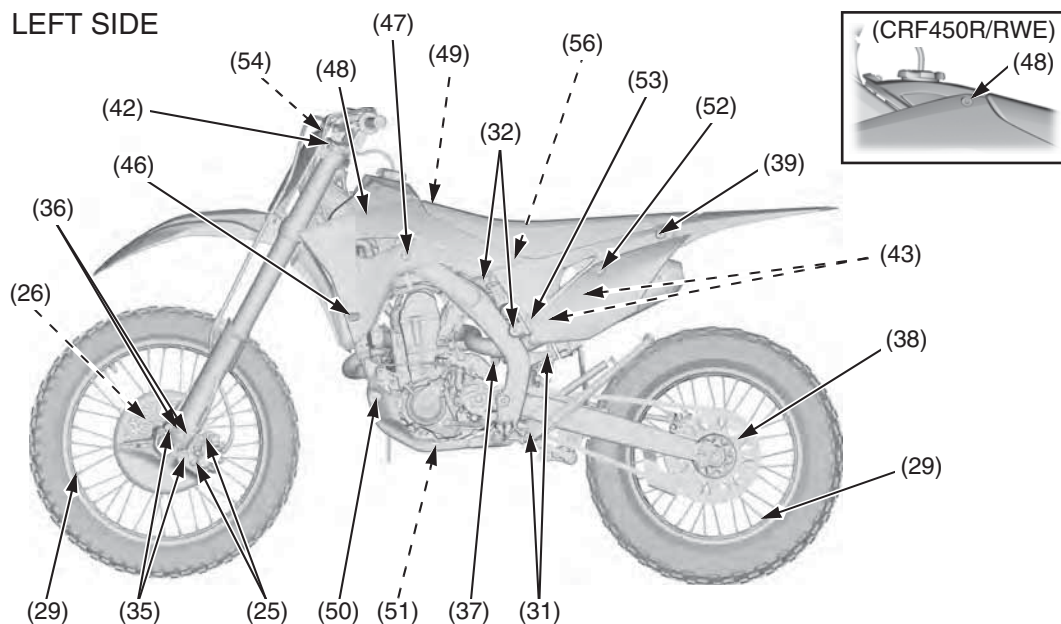

## RIGHT SIDE

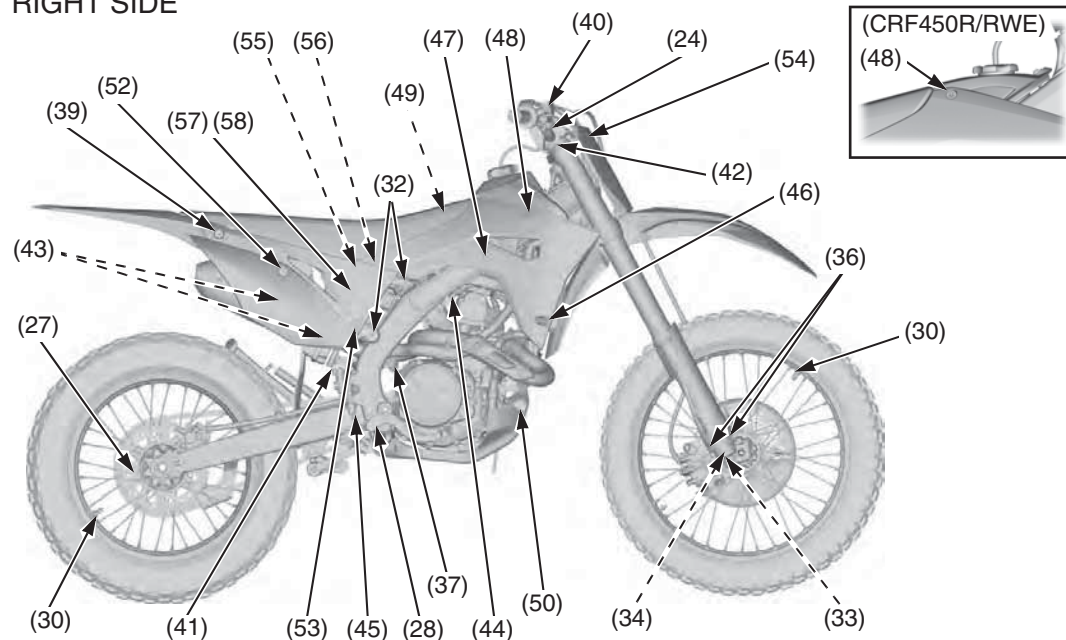

## FRAME

Item	Torque			Remarks		
	lbf-ft	N-m	kgf-m			
24	Brake hose oil bolts	25	34	3.5		
25	Front brake caliper mounting bolts					
26	Front brake disc nuts	12	16	1.6	NOTE 1	
27	Rear brake disc nuts	12	16	1.6	NOTE 1	
28	Brake pedal pivot bolt	27	36	3.7	NOTE 4	
29	Spokes	(front)	2.7	3.7	0.4	
		(rear)	2.7	3.7	0.4	
30	Rim locks	9	12	1.2		
31	Drive chain roller	(upper)	9	12	1.2	NOTE 4
		(lower)	9	12	1.2	NOTE 1
32	Subframe bolts	(upper)	24	32	3.3	
		(lower)	36	49	5.0	
33	Fork center bolt	51	69	7.0		
34	Fork center bolt lock nut	21	28	2.9		
35	Disc cover bolts	10	13	1.3		
36	Fork protector socket bolts	5.2	7.0	0.7	NOTE 4	
37	Left/right muffler clamp bolt (CRF450R/RX)	15	20	2.0		
38	Driven sprocket nuts	24	32	3.3	NOTE 1	
39	Seat mounting bolts	19	26	2.7		
40	Front brake reservoir cap screws	0.7	1.0	0.1		
41	Rear brake reservoir cap bolts	0.7	1.0	0.1		
42	Fork air pressure release screw	1.0	1.3	0.1		
43	Right/left muffler mounting bolt A	19	26	2.7		
	Right/left muffler mounting bolt B	19	26	2.7		
44	Throttle cable adjuster lock nuts	3.0	4.0	0.4		
45	Rear master cylinder push rod lock nut	4.4	5.9	0.6		
46	Shroud A bolts	7	10	1.0		
47	Shroud B bolts	7	10	1.0		
48	Shroud C bolts	3.8	5.2	0.5		
49	Shroud D bolts	3.8	5.2	0.5		
50	Engine guard A bolts/washers	7	10	1.0		
51	Engine guard B bolt/washer	7	10	1.0		
52	Side cover bolts	7	10	1.0		
53	Air cleaner housing cover bolts	7	10	1.0		
54	Number plate bolts	7	10	1.0		
55	Air cleaner retaining bolt	1.8	2.4	0.2		
56	Seat support base mounting bolts	7	10	1.0		
57	Battery cable terminal bolt	5.2	7	0.7		
58	Start magnetic switch stay bolt	9	12	1.2		

NOTES: 1. U-nut

4. Alock bolt: replace with a new one.

## Oxygenated Fuels

---

Some conventional gasolines are being blended with alcohol or an ether compound. These gasolines are collectively referred to as oxygenated fuels. To meet clean air standards, some areas of the United States and Canada use oxygenated fuels to help reduce emissions.

If you use an oxygenated fuel, be sure it is unleaded and meets the minimum octane rating requirement.

Before using an oxygenated fuel, try to confirm the fuel's contents. Some states/province require this information to be posted on the pump.

The following fuel blends are EPA-approved and have been approved for use in your motorcycle:

**ETHANOL** (ethyl or grain alcohol) up to 10% by volume.

You may use gasoline containing up to 10% ethanol by volume. Gasoline containing ethanol may be marketed under the name "Gasohol".

**METHANOL** (methyl or wood alcohol) up to 5% by volume.

You may use gasoline containing up to 5% methanol by volume as long as it also contains cosolvents and corrosion inhibitors to protect the fuel system. Gasoline containing more than 5% methanol by volume may cause starting and/or performance problems.

It may also damage metal, rubber, and plastic parts of your fuel system.

If you notice any undesirable operating symptoms, try another service station or switch to another brand of gasoline.

Fuel system damage or performance problems resulting from the use of an oxygenated fuel containing more than the percentages of oxygenates mentioned above are not covered under warranty.

Oxygenated fuels can damage paint and plastic. Be careful not to spill fuel when filling the fuel tank. Wipe up any spills immediately.

### NOTICE

*Oxygenated fuels can damage paint and plastic.*



Any serious competition effort relies heavily on the knowledge gained and compiled from previous racing events. The best way to organize the many bits of information is to record them in a logbook.

Your logbook can include such information as suspension adjustments, gearing, and tire selection. This detailed information, along with your comments, can prove valuable when you compete at the same track or on similar terrain.

Your logbook can also tell you when maintenance was performed and when it will be necessary again. Your logbook also lets you record any repairs and lets you keep track of the running time on the engine and suspension components.

If you choose to sell your CRF, the accurate maintenance records in your logbook might be the deciding deal-maker for a potential buyer.

Consider using different color pens or pencils to record important information on specific subjects. For example, record results in black, suspension/chassis settings in blue, and gearing selections in green.

Color codes will help you identify the information you want with a glance.

## Tuning & Adjustment Records

Keep track of the settings and adjustments that worked best at a particular location. These items include:

- PGM-FI mode
- HRC-launch control system
- basic track conditions, altitude, and temperature
- suspension settings
- chassis adjustments tested and selected
- gearing
- tire selection
- air pressure

## Competition Records

- your placings
- thoughts to improve performance next time: both yours and your CRF's
- strategy notes

## Maintenance Records

- regular interval maintenance
- repairs
- running time on engine
- running time on suspension components

## Timekeeping

This Manual lists maintenance intervals for every-so-many races (CRF450RX)/motos (CRF450R/RWE) or every-so-many hours of running.

Because all races (CRF450RX)/motos (CRF450R/RWE) are not the same, the most effective way to schedule maintenance is by the hours you have run your CRF.

An official “guesstimate” is close enough for our timekeeping purposes. You may choose to record your time the same way aircraft operators do (but without the benefit of an electrical hourmeter). All running time is broken down into hours and tenths of an hour (each 6 minutes represents one tenth of an hour).

## Racing Records

Information worth recording for this section of your logbook may include:

- Your placing in each race (CRF450RX)/moto (CRF450R/RWE) and overall finishing position.
- Thoughts on what you could do to improve your performance next time.
- Notes on any patterns noted in choice of starting gate positions or in riding portions of the course as the day progressed that may prove helpful in future events.
- Any places on the course where you chose the wrong line and were passed too easily.
- Notes on strategy used by your competition or by riders in another event that are worth remembering.

## Maintenance Records

Regular maintenance items you'll want to record in your logbook should include:

- Dates and results of cylinder, piston and ring examinations
- Patterns for frequency of need for decarbonization with a particular oil
- When you last performed shock linkage and swingarm pivot bearing maintenance
- Engine and suspension oil changes
- Chain, sprocket, chain roller and slider replacements
- Coolant changes and related component replacements
- Spark plug, brake pad and control cable replacements

In addition, you should record any irregularities noted in component wear so you'll remember to keep a close eye on these areas in the future.















# Optional Parts List

These parts and tools may be ordered from your authorized dealer.

FRAME	Remarks
Driven sprocket	< >: Drive chain links CRF450RX: 50 Teeth, Aluminum CRF450R/RWE: 49 Teeth, Aluminum
Standard	<114>
Optional	CRF450RX: 49 Teeth, Aluminum CRF450R/RWE: 48 Teeth, Aluminum
	CRF450RX: 51 Teeth, Aluminum CRF450R/RWE: 50 Teeth, Aluminum
Drive chain size/link	CRF450RX: RK520EXU/120LJFZ CRF450R: RK520TXZ/120RJ
Rear brake pads	
Standard	Characteristics focusing on braking force and wear resistance.
Optional	Characteristics that emphasize controllability.
Rear brake disc cover and bolts	To extend the life of brake pads in muddy conditions.

TOOLS	Remarks
Pin spanner A 	To adjust spring preload. (two spanners required)
Workstand 	For maintenance
Air gauge	For checking tire air pressure

FRAME	Remarks
Fork spring	CRF450RX: 27.4 lbf/in (4.8 N/mm)
Standard (Medium)	 1 scribe mark or no mark (factory products) CRF450R/RWE: 28.6 lbf/in (5.0 N/mm)
	 2 scribe marks or no mark (factory products)
Optional Soft	CRF450RX: 26.3 lbf/in (4.6 N/mm)
Optional Stiff	 1 scribe mark CRF450R/RWE: 27.4 lbf/in (4.8 N/mm)
	 1 scribe mark
Stiff	CRF450RX: 28.6 lbf/in (5.0 N/mm)
	 2 scribe marks CRF450R/RWE: 29.7 lbf/in (5.2 N/mm)
	 3 scribe marks

FRAME	Remarks
Shock spring	CRF450RX: 296.9 lbf/in (52 N/mm) CRF450R/RWE: 319.8 lbf/in (56 N/mm)
Standard (Medium)	CRF450RX: Red paint or no mark (factory products) CRF450R/RWE: Blue paint or no mark (factory products) 
	Optional Soft
Optional Stiff	CRF450RX: 308.3 lbf/in (54 N/mm) CRF450R/RWE: 331.2 lbf/in (58 N/mm)  CRF450RX: White paint CRF450R/RWE: Yellow paint

The standard fork spring and shock spring mounted on the motorcycle when it leaves the factory are not marked. Before replacing the springs, be sure to mark them so they can be distinguished other optional springs.

# Spare Parts & Equipment

There are numerous spare parts you can take to an event to help ensure you get in a full day of riding. In addition to the usual nuts and bolts, consider the following:

## Spare Parts

spark plugs  
air cleaner (clean & oiled, sealed in a plastic bag)  
chain & masterlinks  
chain guide slider  
chain guide  
chain rollers  
tire tubes (front & rear)  
fenders  
footpegs  
fuel feed hose  
fuel pump filter  
number plate & side covers  
handlebar  
grips  
levers (brake & clutch)  
clutch lever handlebar mount  
clutch cable  
throttle assembly  
throttle cable  
shift lever  
brake pedal  
spokes (front & rear, each side)  
sprockets (larger & smaller than standard)  
assorted nuts, bolts, washers, screws, cotter pins

## Additional Spares

fuel pump  
front brake master cylinder  
rear brake assembly  
wheels & tires (front & rear, mounted)  
clutch discs and plates  
engine oil  
seat  
ignition components  
radiator hoses  
radiator shrouds (L & R)  
brake hoses (front & rear)

## General Tools

sockets (3/8 in drive)  
screwdrivers: blade & Phillips No. 1, 2, 3  
wrench, large adjustable  
wrenches: open end & box  
wrenches: hex (Allen)  
wrench, spoke  
torque wrench (metric scale, click-stop style)  
pliers: standard, needle-nose, channel-lock set  
hammer, plastic head  
syringe with adjustable stop  
air pressure gauge  
tire irons  
tire pump or air tank  
feeler gauge set  
Vernier caliper (metric)  
pressure/vacuum testing equipment

## Honda Special Tools

Any special tools for your CRF purchased from your dealer.

- Tensioner stopper 07AMG-001A100
- Lock Nut Wrench 07WMA-KZ30100
- Spoke Wrench 07JMA-MR60100
- Spoke Wrench 070MA-KZ30100
- Piston Base 07958-2500001
- Fork Rod Holder 07AMB-KZ3A100 (USA only)

## Chemical Products

Pro Honda GN4 4-stroke Oil (Engine Oil)  
Pro Honda HP Fork Oil, A15-00  
Honda DOT 4 Brake Fluid  
Pro Honda HP Chain Lube  
Pro Honda Foam Air Filter Oil  
Pro Honda Hondabrite  
Pro Honda Dielectric Grease  
Pro Honda Handgrip Cement  
Pro Honda Hondalock  
Molybdenum disulfide grease (containing more than 3% molybdenum disulfide additive Moly Paste 77)  
Pro Honda Foam Air Filter Sealer  
Multi-Purpose Grease  
Rust-inhibiting oil  
Cable lubricant  
Pro Honda HP Coolant  
Urea based multi-purpose grease designed for high temperature, high pressure performance (example: EXCELITE EP2 manufactured by KYODO YUSHI, Japan or equivalent)

## Other Products

pliers-safety wire  
safety wire  
mechanic's wire  
duct tape  
plastic wire bands  
hose clamps  
drop light  
electrical tape  
Scotch-Brite Hand Pad #7447 (maroon)  
Teflon tape

# Wiring Diagram

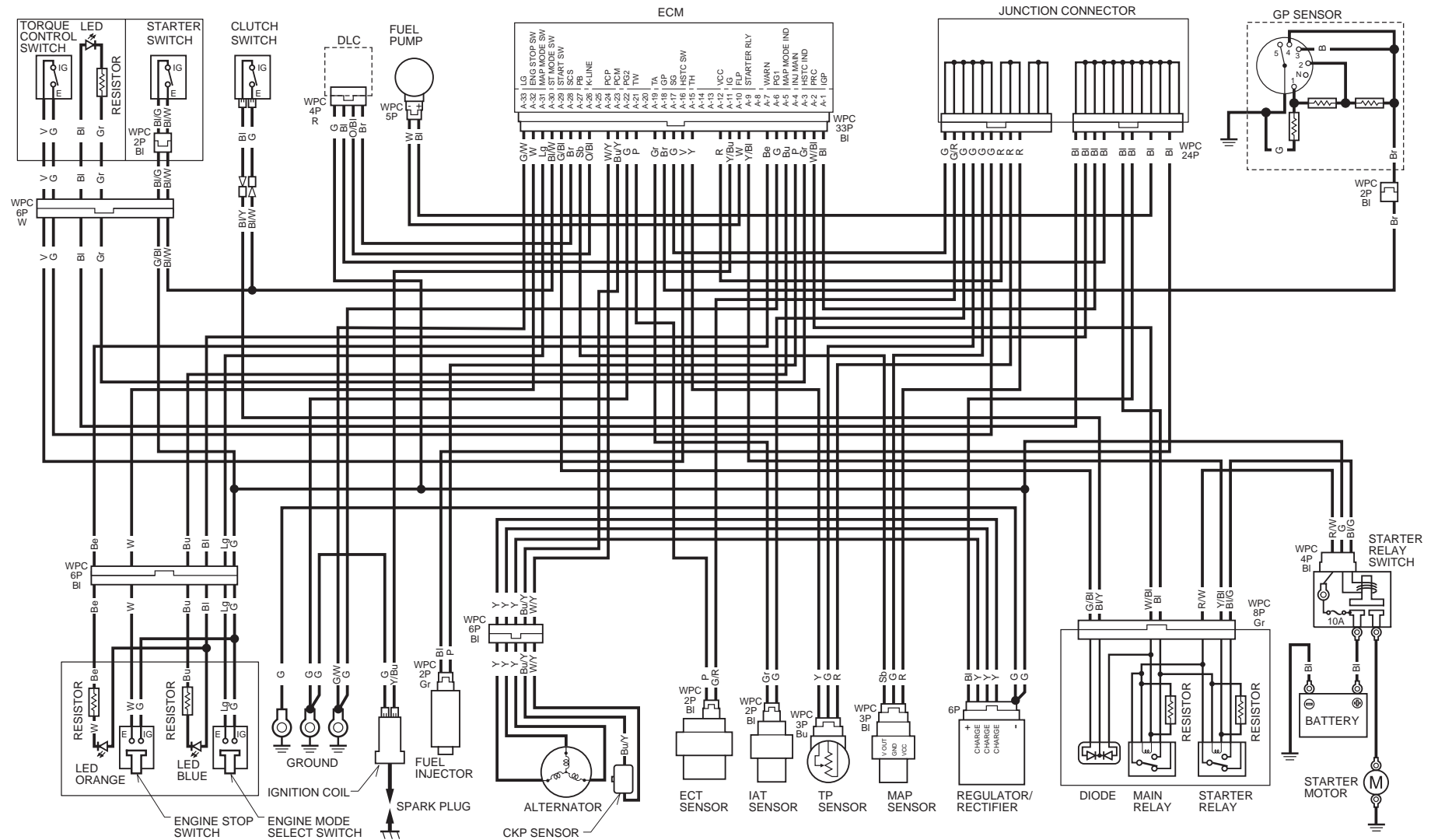

STARTER SWITCH		CLUTCH SWITCH		ENGINE STOP SWITCH		ENGINE MODE SELECT SWITCH		TORQUE CONTROL SWITCH			
	E	IG		E	IG		E	IG		E	IG
PUSH	○	○	FREE	○	○	PUSH	○	○	PUSH	○	○
FREE	○	○	PUSH	○	○	FREE	○	○	FREE	○	○
COLOR	BI/W	BI/Y	COLOR	G	BI	COLOR	W	G	COLOR	G	V

Bl	Black	O	Orange
Be	Beige	P	Pink
Br	Brown	R	Red
Bu	Blue	Sb	Sky blue
G	Green	W	White
Gr	Gray	Y	Yellow
Lg	Light Green	V	Violet

COLOR COMB : GROUND/MARKING

BLANK PAGE



This section contains information about contacting Honda and how to get an official Honda Service Manual.

Authorized Manuals ..... 186  
Contacting Honda ..... 187  
Your Honda Dealer ..... 188

## Authorized Manuals

---

The Service Manual used by your authorized dealer is available from your Honda dealer or Helm, Inc. (USA only, Canada: See your dealer to order authorized manuals.)

Also available but not necessary to service your model is the Honda Common Service Manual which explains theory of operation and basic service information for various systems on Honda motorcycles, scooters and ATV.

The Winter Storage Guide in conjunction with the Owner's Manual and Service Manual can help you prepare your Honda motorcycle, scooter, ATV, and SxS for winter storage.

These Honda manuals are written for the professional technician, but most mechanically-capable owners should find them helpful if they have the proper tools and skills. Special Honda tools are necessary for some procedures.

Publication Item No.	Description
61MKE61	2020 CRF450R/RX/RWE Service Manual
61CSM00	Common Service Manual
S9507	Winter Storage Guide
31MKE630	2020 CRF450RX/R/RWE Owner's Manual

**Order online: [www.helminc.com](http://www.helminc.com)**  
**Order Toll Free: 1-888-CYCLE93 (1-888-292-5393)**  
*(NOTE: For Credit Card Orders Only)*  
Monday - Friday 8:00 AM - 6:00 PM EST

Your owner's manual was written to cover most of the questions you might ask about your CRF. Any questions not answered in the owner's manual can be answered by your dealer. If your dealer doesn't have the answer right away, they will get it for you.

If you have a difference of opinion with your dealer, please remember that each dealership is independently owned and operated. That's why it's important to work to resolve any differences at the dealership level.

If you wish to comment on your experiences with your CRF or with your dealer, please send your comments to the following address:

Motorcycle Division, American Honda Motor Co., Inc., P.O. Box 2200, Torrance CA 90509-2200, Mailstop: 100-4C-7B, Telephone: (866) 784-1870.

Canada: Honda Canada Inc., Customer Relations Dept, 180 Honda Boulevard, Markham, Ontario L6C 0H9, telephone: (888) 946-6329, facsimile: (877) 939-0909. E-mail: [honda\\_cr@ch.honda.com](mailto:honda_cr@ch.honda.com)

Please include the following information in your letter:

- name, address, and telephone number
- product model, year, and VIN
- date of purchase
- dealer name and address

We will likely ask your dealer to respond, or possibly acknowledge your comments directly.

## Your Honda Dealer

---

Once you purchase your new Honda, get familiar with the organization of your Honda dealer so you can utilize the full range of services available.

The service department is there to perform regular maintenance and unexpected repairs. It has the latest available service information from Honda.

The parts department offers Honda Genuine Parts, Pro Honda products, Honda Genuine Accessories (USA only), and Honda accessories and products (Canada only). The same quality that went into your Honda can be found in Honda Genuine replacement parts. You'll also find comparable quality in the accessories and products available from the parts department.

Your Honda dealer can inform you about competition events in your area.

We're sure you'll be as pleased with the service your Honda dealer continues to provide after the sale as you are with the quality and dependability of your Honda.

BLANK PAGE



# Index

## A

accessories.....	3
adjustments,	
chassis.....	156
control freeplay.....	70, 73, 114
for competition.....	139
gearing.....	157
personal fit.....	159
suspension, front.....	143
suspension, rear.....	146
suspension, track conditions.....	151
tire selection, track condition.....	158
after competition maintenance.....	32
air cleaner.....	67
air pressure,	
front suspension.....	143
tires.....	119
apparel, protective.....	2
appearance care.....	136
authorized manuals.....	186

## B

basic operation.....	15
battery.....	134
before riding.....	11
between races (CRF450RX)/motos (CRF450R/RWE) & practice maintenance.....	31
brakes,	
fluid level.....	115
lever, front adjustment.....	114
pad wear.....	117
pedal height.....	114
break-in guidelines.....	20

## C

capacity, fuel.....	42, 52
care, appearance.....	136
chain drive.....	122
chassis adjustments.....	156
cleaner, air.....	67
cleaning, appearance care.....	136
competition logbook.....	179
consumer information.....	185
contacting Honda.....	187
controls.....	5
coolant.....	65
customer service.....	188
cylinder system.....	90

## D

damping adjustments,	
front.....	144
rear.....	147
dealer, your Honda.....	188
diagram, wiring.....	183
drive chain.....	122

## E

Engine Mode & Launch Control System Indicator & Torque Control Indicator.....	10
engine,	
does not start.....	165
flooded.....	18
idle speed.....	72
lacks power.....	165
mode indicator.....	10
mode select button.....	140
number.....	172
oil.....	62
pinging.....	42, 52
starting.....	17
stop button.....	18
stopping.....	18
environment, protecting.....	164

**F**

filter,  
 air .....67  
 fuel pump.....46, 56  
 oil.....63  
 flooded engine, starting.....18  
 fork,  
 front suspension adjustment .....143  
 front suspension inspection .....97  
 oil recommendation .....100  
 front brake lever adjustment.....114  
 front suspension maintenance.....143  
 fuel.....42, 52  
 fuel,  
 line inspection .....42, 52  
 line replacement .....43, 53  
 oxygenated.....178  
 pump filter .....46, 56  
 refueling .....42, 52  
 system .....42, 52  
 tank capacity .....42, 52

**G**

gap, spark plug.....78  
 gasohol.....178  
 gasoline .....42, 52  
 gearing .....157  
 guidelines,  
 suspension adjustment.....152

**H**

handlebar inspection .....132  
 Honda,  
 contacting .....187  
 Selectable Torque Control .....16  
 service manual .....186  
 your dealer .....188  
 HRC-Launch Control System.....142

**I**

identification, vehicle .....172  
 idle knob, fast .....17, 72  
 idle speed, engine .....72  
 indicator,  
 circuit inspection .....8  
 DTC index .....9  
 engine mode.....10, 140  
 launch control system .....10  
 MIL blink .....7  
 torque control .....10  
 inspection, pre-ride.....13  
 instruments .....5

**L**

labels, safety .....4  
 launch control system .....10  
 logbook, competition .....179

**M**

maintenance,  
 after competition .....32  
 before & after competition .....31  
 between races (CRF450RX)/  
 motos (CRF450R/RWE) & practice .....31  
 component locations .....33  
 general competition .....27  
 importance .....22  
 safety .....23  
 schedule.....24  
 manual, service .....186  
 mode indicator .....140  
 modifications .....3

**O**

oil,  
 engine.....62  
 fork .....100  
 operating instructions .....15  
 operation component locations .....6  
 optional,  
 parts list .....181  
 sprockets.....157  
 oxygenated fuels .....178

**P**

pads, brake.....117  
 parts, optional .....181  
 personal fit adjustments .....159  
 pinging, engine .....42, 52  
 plug, spark .....78  
 pre-load, rear suspension.....146  
 pre-ride inspection.....13  
 protective apparel.....2

(cont'd)

# Index

## R

rear suspension adjustment.....	146
riding,	
apparel.....	2
basic operation .....	15
before .....	11
important safety information .....	2
safety precautions .....	2

## S

safety,	
a few words about.....	Safety Messages
important information .....	2
important precautions.....	2
labels .....	4
maintenance .....	23
riding precautions .....	16
schedule, maintenance .....	24
seat.....	34
serial numbers.....	172
service,	
customer .....	188
manuals .....	186
side stand (CRF450RX).....	121
spare parts.....	182
spark knock .....	42, 52
spark plug,	
maintenance .....	78
reading.....	155
specifications .....	173
spring pre-load, rear suspension .....	146
starting,	
engine .....	17
troubleshooting.....	165
steering stem inspection.....	132
stopping engine .....	18
storage.....	163
subframe.....	39
suspension adjustment,	
for track conditions.....	151
front .....	143
guidelines.....	152
rear .....	146
suspension,	
front .....	97
rear .....	113

## T

throttle,	
freeplay.....	70
inspection .....	71
lubrication.....	71
tires,	
air pressure.....	119
flat.....	119
selection.....	120
tools .....	182
torque specifications,	
engine.....	175
frame .....	176, 177
transporting.....	162
troubleshooting .....	165
tubes, replacing .....	119
tuning tips.....	155

## V

valve clearance.....	79
vehicle identification no. (VIN).....	172

## W

washing your motorcycle .....	136
wheels .....	118
wiring diagram.....	183

# Quick Reference

The following is a brief, but important collection of information you need to know about your CRF. You'll also find space to record important notes.

## How To Avoid Costly Repairs

The engine of your CRF can be the most expensive component to repair. Proper maintenance, especially the use of the recommended fluids and filters, prevents premature wear and damage.

Frequent causes of costly engine repairs are:

- Transmission oil & engine oil: insufficient quantity, improper oil.
- Air cleaner: dirty, leaking because of improper installation (poor seal)

Record important information here:

VIN	
Engine No.	
Owner's:	
Name	
Address	
City/State	
Phone	
Dealer's:	
Name	
Address	
City/State	
Phone	
Service Mgr.	

Maintenance	<p>CRF450RX: The maintenance schedule (page 25) lists service frequencies for: each race or about 3.5 hours, every 2 races or about 7.5 hours, every 4 races or about 15.0 hours, every 6 races or about 22.5 hours and every 8 races or about 30.0 hours</p> <p>CRF450R/RWE: The maintenance schedule (page 26) lists service frequencies for: each race or about 2.5 hours, every 3 races or about 7.5 hours, every 6 races or about 15.0 hours, every 9 races or about 22.5 hours and every 12 races or about 30.0 hours</p>			
Pre-ride Inspection	Check the items listed on the Pre-ride Inspection checklist each time before you ride (page 13)			
Fuel/Tank Capacity	<p>CRF450RX: unleaded gasoline, pump octane number of 91 or higher tank: 2.25 US gal (8.5 ℓ)</p> <p>CRF450R/RWE: unleaded gasoline, pump octane number of 91 or higher tank: 1.66 US gal (6.3 ℓ)</p>			
Engine Oil/Capacity	<p>Pro Honda GN4 4-stroke Oil or an equivalent motorcycle oil. 1.10 US qt (1.04 ℓ) after draining and filter change 1.06 US qt (1.00 ℓ) after draining</p>			
Tires	Front	CRF450RX: 90/90-21 54M	Rear	CRF450RX: 120/90-18 65M
		CRF450R/RWE: 80/100-21 51M		CRF450R/RWE: 120/80-19 63M
		DUNLOP	CRF450RX: AT81F CRF450R/RWE: MX3SF	DUNLOP
	Type	bias-ply, tube		
Tire Pressure (cold)	<p>Front: 15 psi (100 kPa, 1.0 kgf/cm<sup>2</sup>) Rear: 15 psi (100 kPa, 1.0 kgf/cm<sup>2</sup>)</p>			
Spark Plug	<p>standard: SILMAR9A-9S (NGK) optional: SILMAR10A-9S (NGK)</p>			
Coolant	ethylene glycol antifreeze (silicate-free) for aluminum engines in 50/50 solution with Pro Honda HP Coolant or an equivalent distilled water.			
Fuse	main: 10 A			
Drive Chain Size/Link	<p>CRF450RX: RK520EXU/114LE CRF450R: RK520TXZ/114RJ CRF450RWE: GB520TXZ/114RJ</p>			

California Proposition 65 Warning

**⚠️WARNING:** Operating, servicing and maintaining a passenger vehicle or off-highway motor vehicle can expose you to chemicals including engine exhaust, carbon monoxide, phthalates, and lead, which are known to the State of California to cause cancer and birth defects or other reproductive harm. To minimize exposure, avoid breathing exhaust, do not idle the engine except as necessary, service your vehicle in a well-ventilated area and wear gloves or wash your hands frequently when servicing your vehicle. For more information go to [www.P65Warnings.ca.gov/passenger-vehicle](http://www.P65Warnings.ca.gov/passenger-vehicle).