

# Contents

**Motorcycle Safety** P. 2

**Operation Guide** P. 18

**Maintenance** P. 114

**Troubleshooting** P. 178

**Information** P. 199

**Specifications** P. 223

**Index** P. 227

# Welcome

Congratulations on your purchase of a new Honda motorcycle. Your selection of a Honda makes you part of a worldwide family of satisfied customers who appreciate Honda's reputation for building quality into every product.

To ensure your safety and riding pleasure:

- Read this owner's manual carefully.
- Follow all recommendations and procedures contained in this manual.
- Pay close attention to safety messages contained in this manual and on the motorcycle.

To protect your investment, we urge you to take responsibility for keeping your motorcycle well serviced and maintained. Also, observe the break-in guidelines, and always perform the pre-ride inspection and other periodic checks in this manual.

When service is required, remember that your Honda dealer knows your motorcycle best. If you have the required mechanical "know-how" and tools, you can purchase an official Honda Service Manual to help you perform many maintenance and repair tasks. ≥ P. 217

Read the warranty information thoroughly so that you understand the warranty coverage and that you are aware of your rights and responsibilities. ≥ P. 218

You may also want to visit our website at [www.powersports.honda.com](http://www.powersports.honda.com).

**Canada** [www.honda.ca](http://www.honda.ca).

Happy riding!

California Proposition 65 Warning

**WARNING:** This product contains or emits chemicals known to the State of California to cause cancer and birth defects or other reproductive harm.

## A Few Words About Safety

Your safety, and the safety of others, is very important. Operating this motorcycle safely is an important responsibility.

To help you make informed decisions about safety, we have provided operating procedures and other information on safety labels and in this manual. This information alerts you to potential hazards that could hurt you or others.

Of course, it is not practical or possible to warn you about all hazards associated with operating or maintaining a motorcycle. You must use your own good judgment.

You will find important safety information in a variety of forms, including:

- Safety labels on the motorcycle
- Safety Messages preceded by a safety alert symbol  and one of three signal words: DANGER, WARNING, or CAUTION.

These signal words mean:

### **3 DANGER**

You **WILL** be **KILLED** or **SERIOUSLY HURT** if you don't follow instructions.

### **3 WARNING**

You **CAN** be **KILLED** or **SERIOUSLY HURT** if you don't follow instructions.

### **3 CAUTION**

You **CAN** be **HURT** if you don't follow instructions.

**Other important information is provided under the following titles:**

**NOTICE** Information to help you avoid damage to your motorcycle, other property, or the environment.

# Motorcycle Safety

This section contains important information for safe riding of your motorcycle.  
Please read this section carefully.

<b>Safety Guidelines</b> .....	P. 3
<b>Safety Labels</b> .....	P. 8
<b>Safety Precautions</b> .....	P. 10
<b>Riding Precautions</b> .....	P. 12
<b>Accessories &amp; Modifications</b> .....	P. 16
<b>Loading</b> .....	P. 17

## Safety Guidelines

Follow these guidelines to enhance your safety:

- Perform all routine and regular inspections specified in this manual.
- Stop the engine and keep sparks and flame away before filling the fuel tank.
- Do not run the engine in enclosed or partly enclosed areas. Carbon monoxide in exhaust gases is toxic and can kill you.

### Always Wear a Helmet

It's a proven fact: helmets and protective apparel significantly reduce the number and severity of head and other injuries. So always wear an approved motorcycle helmet and protective apparel. 2 P. 10

### Before Riding

Make sure that you are physically fit, mentally focused and free of alcohol and drugs.

#### CBR1000RR/RA

Check that you and your passenger are both wearing an approved motorcycle helmet and protective apparel. Instruct your passenger on holding onto the seat strap or your waist, leaning with you in turns, and keeping their feet on the footpegs, even when the motorcycle is stopped.

#### CBR1000S1

Check that you are wearing an approved motorcycle helmet and protective apparel.

### Take Time to Learn & Practice

Even if you have ridden other motorcycles, practice riding in a safe area to become familiar with how this motorcycle works and handles, and to become accustomed to the motorcycle's size and weight.

We recommend that all riders take a certified course approved by the Motorcycle Safety Foundation (MSF). New riders should start with the basic course, and even experienced riders will find the advanced course beneficial.

For information about the MSF training course nearest you, call the national toll-free number: (800) 446-9227.

**USA** Other riding tips can be found in the You and Your Motorcycle Riding Tips booklet that came with your motorcycle.

### Ride Defensively

Always pay attention to other vehicles around you, and do not assume that other drivers see you. Be prepared to stop quickly or perform an evasive maneuver.

### Make Yourself Easy to See

Make yourself more visible, especially at night, by wearing bright reflective clothing, positioning yourself so other drivers can see you, signaling before turning or changing lanes, and using your horn when necessary.

### **Ride within Your Limits**

Never ride beyond your personal abilities or faster than conditions warrant. Fatigue and inattention can impair your ability to use good judgment and ride safely.

### **Never Carry a passenger**

#### **CBR1000S1**

There are no handholds, seat, or footrest to carry a passenger.

### **Don't Drink and Ride**

Alcohol and riding don't mix. Even one alcoholic drink can reduce your ability to respond to changing conditions, and your reaction time gets worse with every additional drink. Don't drink and ride, and don't let your friends drink and ride either.

### **Keep Your Honda in Safe Condition**

It's important to keep your motorcycle properly maintained and in safe riding condition. Inspect your motorcycle before every ride and perform all recommended maintenance. Never exceed load limits (2 P. 17), and do not modify your motorcycle or install accessories that would make your motorcycle unsafe (2 P. 16).

### If You are Involved in a Crash

Personal safety is your first priority. If you or anyone else has been injured, take time to assess the severity of the injuries and whether it is safe to continue riding. Call for emergency assistance if needed. Also follow applicable laws and regulations if another person or vehicle is involved in the crash.

If you decide to continue riding, first turn the ignition switch to the OFF position, and evaluate the condition of your motorcycle. Inspect for fluid leaks, check the tightness of critical nuts and bolts, and check the handlebars, control levers, brakes, and wheels. Ride slowly and cautiously.

Your motorcycle may have suffered damage that is not immediately apparent. Have your motorcycle thoroughly checked at a qualified service facility as soon as possible.

### Lithium-Ion (Li-Ion) Battery

#### CBR1000S1

If you smell an unusual odor coming from the lithium-ion (li-ion) battery, park your motorcycle in a safe place outside and away from flammable objects, then turn the ignition switch to the OFF position. Have your motorcycle inspected by your dealer immediately.



### Carbon Monoxide Hazard

Exhaust contains poisonous carbon monoxide, a colorless, odorless gas. Breathing carbon monoxide can cause loss of consciousness and may lead to death.

If you run the engine in confined or even partly enclosed area, the air you breathe could contain a dangerous amount of carbon monoxide.

Never run your motorcycle inside a garage or other enclosure.

### 3 WARNING

Running the engine of your motorcycle while in an enclosed or even partially enclosed area can cause a rapid build-up of toxic carbon monoxide gas.

Breathing this colorless, odorless gas can quickly cause unconsciousness and lead to death.

Only run your motorcycle's engine when it is located in a well ventilated area outdoors.

## Safety Labels

Safety and information labels on your motorcycle provide important safety information and may warn you of potential hazards that could cause serious injury. Read these labels carefully and don't remove them.

If a label comes off or becomes hard to read, contact your dealer for a replacement.

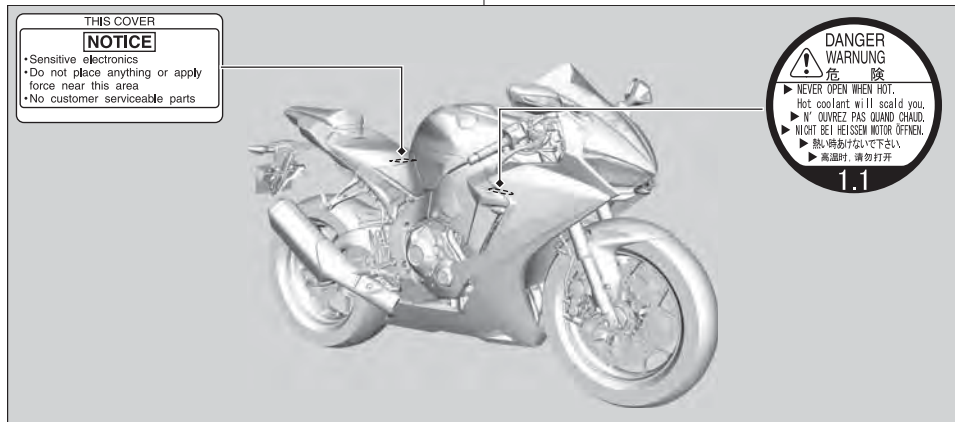

**▲ WARNING**

Improper loading can cause a crash and you may be seriously hurt or killed. See "Load Limits and Guidelines" in your Owner's Manual for complete instructions.

UNLEADED FUEL ONLY  
PREMIUM RECOMMENDED

**CBR1000RR/RA**

TIRE INFORMATION				DRIVE CHAIN		
Cold tire pressures	Front	250	2.50	36	Keep chain adjusted and lubricated 30 mm (1 1/4 in.) Freeplay	
	Rear	290	2.90	42		
Up to 90kg(200lbs) load	Front	250	2.50	36		
	Rear	290	2.90	42		
Tire size	Front	120/70 ZH17 M/C 65W			Read owner's manual.	
	Rear	190/50 ZH17 M/C 73W				
Min. recommend tire center tread depth.	Front	1.5mm (0.06in.)				
Maximum weight capacity	Rear	2.0mm (0.08in.)				
		166kg(366lbs)				

**CBR1000S1**

TIRE INFORMATION				DRIVE CHAIN		
Cold tire pressures	Front	250	2.50	36	Keep chain adjusted and lubricated 30 mm (1 1/4 in.) Freeplay	
	Rear	290	2.90	42		
Tire size	Front	120/70 ZH17 M/C 65W				
	Rear	190/50 ZH17 M/C 73W				
Min. recommend tire center tread depth.	Front	1.5mm (0.06in.)				
Maximum weight capacity	Rear	2.0mm (0.08in.)				
		110kg(243lbs)				

**CBR1000RR/RA**

For your protection, always wear your helmet while riding. Read the owner's manual carefully.

**CBR1000S1**

For your protection, always wear your helmet while riding. Operator only. No passengers. Read the owner's manual carefully.

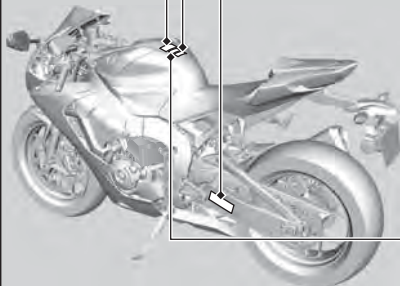

## Safety Precautions

- Ride cautiously and keep your hands on the handlebars and feet on the footpegs.
  - **CBR1000RR/RA**  
Keep passenger's hands onto the seat strap or your waist, passenger's feet on the footpegs while riding.
  - **CBR1000RR/RA**  
Always consider the safety of your passenger, as well as other drivers and riders.
- CBR1000S1**  
Always consider the safety of other drivers and riders.

## Protective Apparel

### **CBR1000RR/RA**

Make sure that you and any passenger are wearing an approved motorcycle helmet, eye protection, and high-visibility protective clothing. Ride defensively in response to weather and road conditions.

### **CBR1000S1**

Make sure that you are wearing an approved motorcycle helmet, eye protection, and high-visibility protective clothing. Ride defensively in response to weather and road conditions.

## Helmet

Should be safety-standard certified, high-visibility, and correct size for your head.

- Must fit comfortably but securely, with the chin strap fastened.
- Face shield with unobstructed field of vision or other approved eye protection.

**USA** Look for a DOT (Department of Transportation) certification label on any helmet you buy.

**CBR1000RR/RA**

## **3** WARNING

Not wearing a helmet increases the chance of serious injury or death in a crash.

Make sure that you and any passenger always wear an approved helmet and protective apparel.

**CBR1000S1**

## **3** WARNING

Not wearing a helmet increases the chance of serious injury or death in a crash.

Make sure that you always wear an approved helmet and protective apparel.

### **| Gloves**

Full-finger leather gloves with high abrasion resistance.

### **| Boots or Riding Shoes**

Sturdy boots with non-slip soles and ankle protection.

### **| Jacket and Pants**

Protective, highly visible, long-sleeved jacket and durable long pants for riding (or a protective suit).

## Riding Precautions

### Break-in Period

During the first 300 miles (500 km) of running, follow these guidelines to ensure your motorcycle's future reliability and performance.

- Avoid full-throttle starts and rapid acceleration.
- Avoid hard braking and rapid down-shifts.
- Ride conservatively.

### Brakes

Observe the following guidelines:

- Avoid excessively hard braking and downshifting.
  - ⌋ Sudden braking can reduce the motorcycle's stability.
  - ⌋ Where possible, reduce speed before turning; otherwise you risk sliding out.

- Exercise caution on low traction surfaces.
  - ⌋ The tires slip more easily on such surfaces and braking distances are longer.
- Avoid continuous braking.
  - ⌋ Repeated braking, such as when descending long, steep slopes can seriously overheat the brakes, reducing their effectiveness. Use engine braking with intermittent use of the brakes to reduce speed.
- For full braking effectiveness, operate both the front and rear brakes together.

## Anti-lock Brake System (ABS)

### CBR1000RA/S1

This model is equipped with an Anti-lock Brake System (ABS) designed to help prevent the brakes from locking up during hard braking. The ABS functions with information provided by the IMU (Inertia Measurement Unit).

- ABS does not reduce braking distance. In certain circumstances, ABS may result in a longer stopping distance.
- ABS does not function at speeds below 4 mph (6 km/h).
- The brake lever and pedal may recoil slightly when applying the brakes. This is normal.
- Always use the recommended front/rear tires and sprockets to ensure correct ABS operation.

## Engine Braking

Engine braking helps slow your motorcycle down when you release the throttle. For further slowing action, downshift to a lower gear. Use engine braking with intermittent use of the brakes to reduce speed when descending long, steep slopes.

## Wet or Rainy Conditions

Road surfaces are slippery when wet, and wet brakes further reduce braking efficiency. Exercise extra caution when braking in wet conditions. If the brakes get wet, apply the brakes while riding at low speed to help them dry.

### Parking

- Park on a firm, level surface.
- If you must park on a slight incline or loose surface, park so that the motorcycle cannot move or fall over.
- Make sure that high-temperature parts cannot come into contact with flammable materials.
- Do not touch the engine, muffler, brakes and other high-temperature parts until they cool down.
- To reduce the likelihood of theft, always lock the handlebars and remove the key when leaving the motorcycle unattended. Use of an anti-theft device is also recommended.

### ■ Parking with the Side Stand

1. Stop the engine.
2. Push the side stand down.

3. Slowly lean the motorcycle to the left until its weight rests on the side stand.
4. Turn the handlebars fully to the left.
  - ⊣ Turning the handlebars to the right reduces stability and may cause the motorcycle to fall.
5. Turn the ignition switch to the LOCK position and remove the key. 2 P. 100

### Refueling and Fuel Guidelines

Follow these guidelines to protect the engine, fuel system and catalytic converter:

- Use only unleaded gasoline.
- Use recommended octane number. Using lower octane gasoline will result in decreased engine performance.
- Do not use fuels containing a high concentration of alcohol. 2 P. 216
- Do not use stale or contaminated gasoline or an oil/gasoline mixture.
- Avoid getting dirt or water in the fuel tank.



## Honda selectable torque control

When the Honda selectable torque control (Torque Control) detects rear wheel spin during acceleration, the system will limit the amount of torque applied to the rear wheel based on the Torque Control level selected.

Additionally, the system eases the rapid motion during the wheelie when accelerating based on the Torque Control level selected.

Torque Control will allow some wheel spin during acceleration at the lower Torque Control levels settings. Select a level that is appropriate for your skill and riding conditions.

Torque Control does not work during deceleration and will not prevent the rear wheel from skidding due to engine braking. Do not close the throttle suddenly, especially when riding on slippery surfaces.

Torque Control may not compensate for rough road conditions or rapid throttle operation.

Always consider road and weather conditions, as well as your skills and condition, when applying throttle.

If your motorcycle gets stuck in mud, snow or sand, it may be easier to free it with the Torque Control (T value) temporarily changed to level 0.

Temporarily changing the Torque Control level to 0 also may help you maintain control and balance when riding on off-road terrain.

Always use the recommended tires and sprockets to ensure correct Torque Control operation.

## Accessories & Modifications

We strongly advise that you do not add any accessories that were not specifically designed or approved for your motorcycle by Honda or make modifications to your motorcycle from its original design. Doing so can make it unsafe. Modifying your motorcycle may also void your warranty and make your motorcycle illegal to operate on public roads and highways. Before deciding to install accessories on your motorcycle be certain the modification is safe and legal.

### **3**WARNING

Improper accessories or modifications can cause a crash in which you can be seriously hurt or killed.

Follow all instructions in this owner's manual regarding accessories and modifications.

Do not pull a trailer with, or attach a sidecar to, your motorcycle. Your motorcycle was not designed for these attachments, and their use can seriously impair your motorcycle's handling.

#### **CBR1000S1**

Do not attempt modify the motorcycle to carry a passenger. The subframe was not designed to carry the additional weight of a passenger.

## Loading

### ● CBR1000S1

Never carry a passenger. Your motorcycle was not designed to carry a passenger.

- Carrying extra weight affects your motorcycle's handling, braking and stability. Always ride at a safe speed for the load you are carrying.
- Avoid carrying an excessive load and keep within specified load limits.

**Maximum weight capacity** ≥ P. 223

- Tie all luggage securely, evenly balanced and close to the center of the motorcycle.
- Do not place objects near the lights or the muffler.

### CBR1000RR/RA

## 3 WARNING

Overloading or improper loading can cause a crash and you can be seriously hurt or killed.

Follow all load limits and other loading guidelines in this manual.

### CBR1000S1

## 3 WARNING

Overloading improper loading or carrying a passenger can cause a crash and you can be seriously hurt or killed.

Follow all load limits and other loading guidelines in this manual.

# Parts Location

CBR1000RR/RA

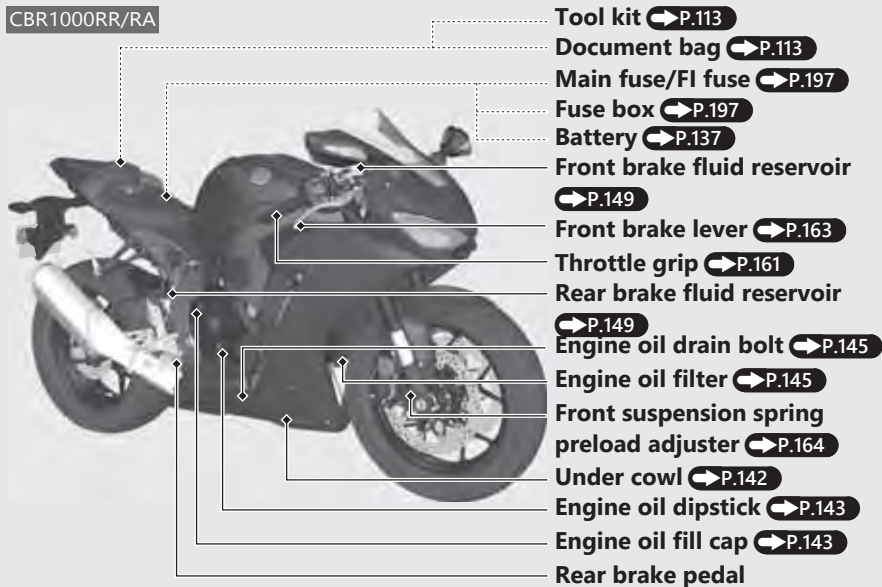

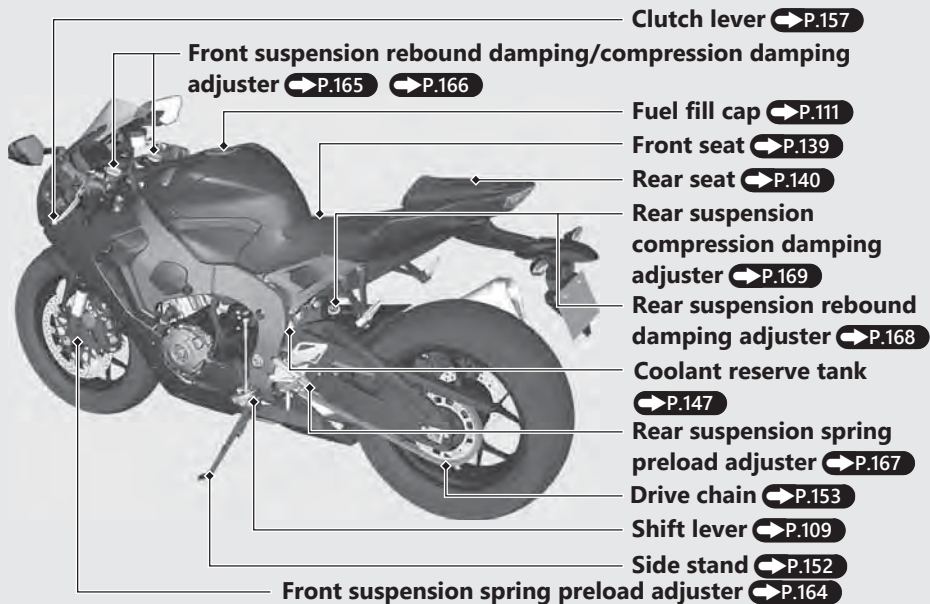

## Parts Location *(Continued)*

CBR1000S1

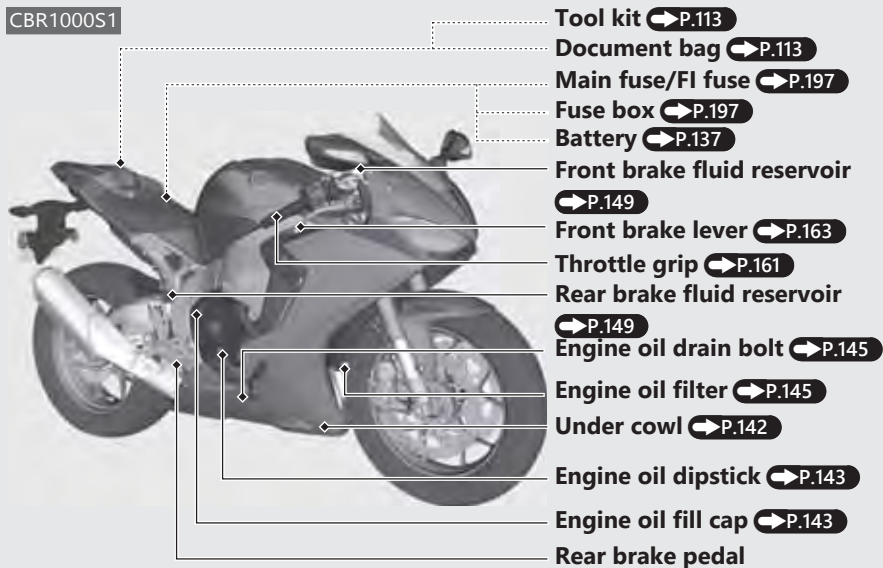

Tool kit ➔ P.113

Document bag ➔ P.113

Main fuse/FI fuse ➔ P.197

Fuse box ➔ P.197

Battery ➔ P.137

Front brake fluid reservoir  
➔ P.149

Front brake lever ➔ P.163

Throttle grip ➔ P.161

Rear brake fluid reservoir  
➔ P.149

Engine oil drain bolt ➔ P.145

Engine oil filter ➔ P.145

Under cowl ➔ P.142

Engine oil dipstick ➔ P.143

Engine oil fill cap ➔ P.143

Engine oil fill cap ➔ P.143

Rear brake pedal

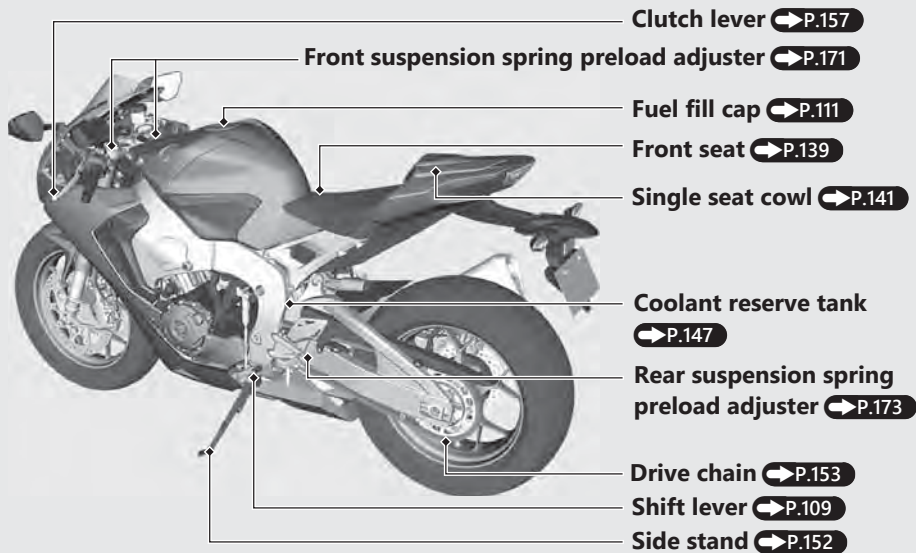

# Instruments

## Street mode

### Clock (12-hour display)

To set the clock: ➡ P.70

### Tachometer

#### NOTICE

Do not operate the engine in the tachometer red zone. Excessive engine speed can adversely affect engine life.

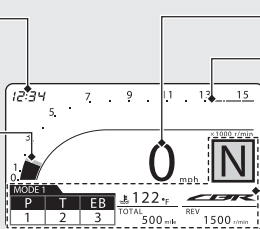

### Speedometer

### Tachometer red zone

(excessive engine rpm range)

## Display Check

When the ignition switch is turned to the ON position, the opening symbol will show on the display. If the display itself does not show when it should, have your dealer check for problems.

You can select the street mode or circuit mode display.

To change the circuit mode: ➡ P.24



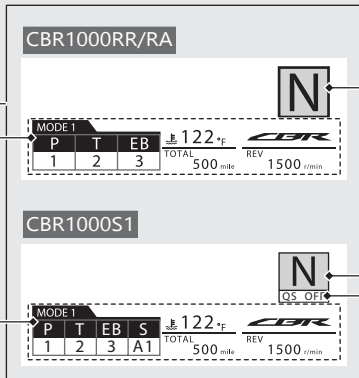

**Multi-information display** P.25

### **Gear position indicator**

Shows 1st to 6th gear positions. “-” appears when the transmission is not shifted properly.

### **Quick Shifter indicator**

Displays the current status of the Quick Shifter.

: Quick Shifter system is disabled.

: Quick Shifter upshifting is enabled.

: Quick Shifter downshifting is enabled.

: Quick Shifter upshifting and downshifting are both enabled.

**QUICK SHIFTER:** P.45 P.46

P.110

## Instruments (Continued)

### Circuit mode

#### To Change to the circuit mode :

- Press and hold the **LAP** button with your motorcycle stopped.
  - ↳ To return to the street mode display, press and hold the **LAP** button.
- Select the "CIRCUIT" menu on the "DISPLAY" screen. **➡P.43** **➡P.59**
  - ↳ To return to the street mode display, select the "STREET" menu on the "DISPLAY"

#### Lap timer

**➡P.86**

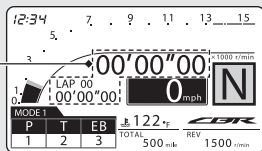

#### LAP button



### Display Check

When the ignition switch is turned to the ON position, the opening symbol will show on the display. If the display itself does not show when it should, have your dealer check for problems.

## Multi-information display

Multi-information display can display the coolant temperature gauge, riding modes, INFO 1, INFO 2 and INFO 3 displays.

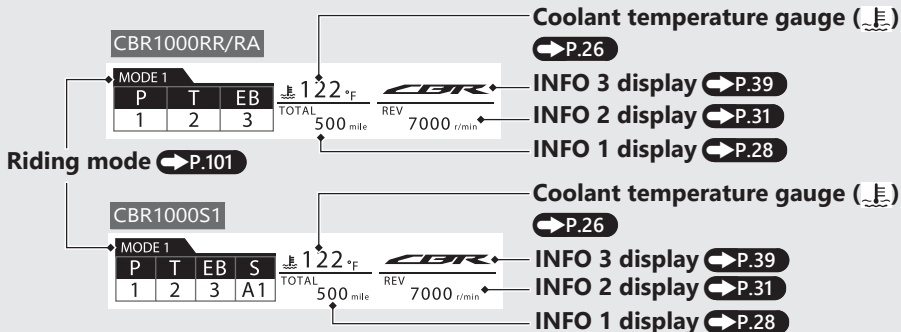

You can change the riding modes, INFO1, INFO 2 and INFO 3 displays of the Multi-information display.

**To switch the multi-information display:** → P.27

## Instruments *(Continued)*

### Coolant temperature gauge ( )

Display range: 94 °F (35 °C) to 269 °F (132 °C)

- 93°F (34°C) or less: "---" is displayed.
- Between 251°F (122°C) and 268°F (131°C) :
  - High coolant temperature indicator lights.
  - Coolant temperature digits flash.
- Above 269°F (132°C):
  - High coolant temperature indicator lights.
  - "269°F (132°C)" flashes.
- Even if the engine coolant temperature is low, the cooling fan may start running when you rev up the engine. This is normal.

### Pop-up information

In the following cases, the INFO 3 display, or the INFO 3 display and the coolant temperature gauge change to a pop-up information display.

- When an inspection time of your motorcycle is approaching.
- When your motorcycle has helpful information.
- When your motorcycle has a problem with the PGM-FI system.
- **CBR1000S1**

When your motorcycle has a problem with the ÖHLINS Smart EC system.

**Information of the pop-up information:**  **P.90**

## To Switch the multi-information display

To select the display area, repeatedly press the **MODE** button.

⌋ Can not select the INFO 3 display while pop-up information displayed. **➡P.90**

If the **MODE** button is not pressed within 10 seconds, the display returns to the riding mode display.

### Riding mode **➡P.101**

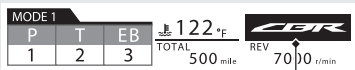
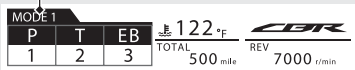

### INFO 3 display **➡P.39**

➡ Press the **MODE** button

### INFO 1 display **➡P.28**



### INFO 2 display **➡P.31**

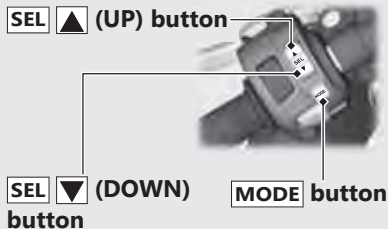

## Instruments (Continued)

### INFO 1 display

You can select the following:

- Odometer [TOTAL]
- Tripmeter [TRIP A/B]

### Changing the INFO 1 display

- 1 Select the INFO 1 display. **➡ P.27**
- 2 Press the **SEL** **▲** (up) or **SEL** **▼** (down) button until the desired indication is displayed.
- 3 Press the **MODE** button. The INFO 1 display is set, and then the display moves to the INFO 2 display.

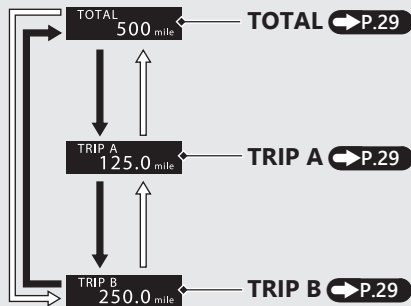

**➡** Press the **SEL** **▲** (up) button

**↩** Press the **SEL** **▼** (down) button

## Odometer [TOTAL]

Total distance ridden.



TOTAL  
500 mile

When "-----" is displayed, go to your dealer for service.

## Tripmeter A/B [TRIP A/B]

Distance ridden since the tripmeter was reset.

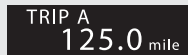

TRIP A  
125.0 mile

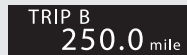

TRIP B  
250.0 mile

When "----.-" is displayed, go to your dealer for service.

**To reset the tripmeter:**  **P.30**

## Instruments *(Continued)*

### To reset the tripmeter and tripmeter A fuel consumption

To reset tripmeter A and tripmeter A fuel consumption together, press and hold the **MODE** button with the tripmeter A or tripmeter A fuel consumption displayed.

#### Tripmeter A

TRIP A  
125.0 mile

or

#### Tripmeter A fuel consumption

TRIP A CONS.  
15.0 GAL



TRIP A  
0.0 mile

or

TRIP A CONS.  
-.- GAL

To reset the tripmeter B, press and hold the **MODE** button with the tripmeter B displayed.

TRIP B  
250.0 mile

Tripmeter B



TRIP B  
0.0 mile





## INFO 2 display

You can select the following:

- Numerical tachometer display [REV]
- Current fuel mileage [INST. CONS.]
- Average fuel mileage [AVE. CONS.]
- Tripmeter A fuel consumption [TRIP A CONS.]
- Average speed [AVG. SPD.]
- Elapsed time [ELAPSED]
- Available driving distance [RANGE]
- Amount of remaining fuel [REMAIN]

### Changing the INFO 2 display

- 1 Select the INFO 2 display.  **P.27**
- 2 Press the **SEL**  (up) or **SEL**  (down) button until the desired display is displayed.
- 3 Press the **MODE** button. The INFO 2 display is set, and display moves to the INFO 3 display.

## Instruments (Continued)

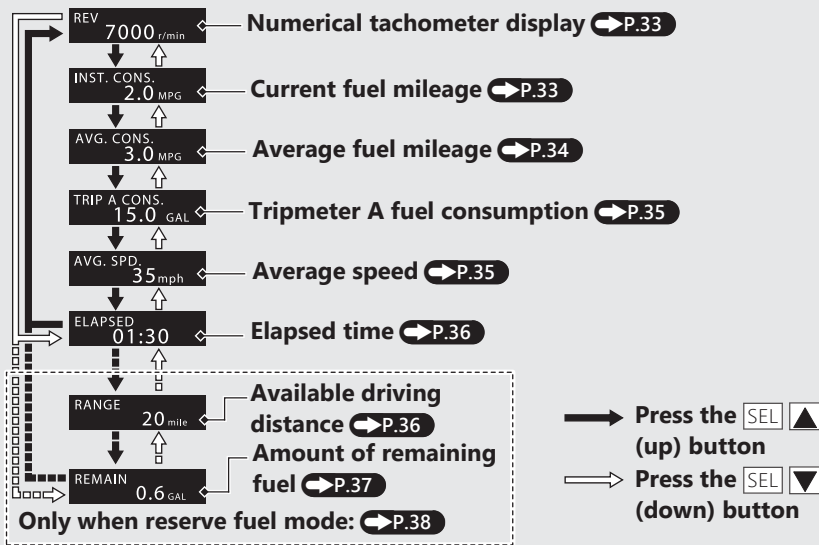

When the low fuel indicator lights and the low fuel pop-up information appear, INFO 3 display will automatically switch to the amount of remaining fuel display.

**Numerical tachometer Display [REV]**

Displays engine revolutions per minutes.

Display range: 0 to 15,400 r/min (rpm)

- Above 15,400 r/min (rpm): "15400" is displayed.



REV  
7000 r/min

**Current fuel mileage [INST. CONS.]**

Displays the current instant fuel mileage.

Display range: 0.0 to 99.9 MPG (mile/L, L/100km or km/L)

- When your speed is less than 4 mph (7 km/h): "--.-" is displayed.
- Above 99.9 MPG (mile/L or km/L): "99.9" is displayed.
- Above 99.9 L/100km: "--.-" is displayed.



INST. CONS.  
2.0 MPG

When "--.-" is displayed except for the above-mentioned cases, go to your dealer for service.

## Instruments *(Continued)*

### Average fuel mileage [AVG. CONS.]

Displays the average fuel mileage since the average fuel mileage was reset.

Display range: 0.0 to 99.9 MPG (mile/L, L/100km or km/L)

- Above 99.9 MPG (mile/L or km/L): "99.9" is displayed.
- Above 99.9 L/100km: "--.-" is displayed.
- When the average fuel mileage is reset: "--.-" is displayed.

AVG. CONS.  
3.0 MPG

When "--.-" is displayed except for the above-mentioned cases, go to your dealer for service.

### To reset the average fuel mileage

Press and hold the **MODE** button with the average fuel mileage displayed.



## Tripmeter A fuel consumption [TRIP A CONS.]

Displays the tripmeter A fuel consumption since the tripmeter A was reset.

Display range: 0.0 to 300.0 GAL (gallon) or 0.0 to 300.0 L (liters)

- Above 300 GAL (gallon) or 300 L (liters): "300.0" is displayed.
- When the tripmeter A fuel consumption is reset: "---.-" is displayed.

TRIP A CONS.  
15.0 GAL

When "---.-" is displayed except for the above-mentioned cases, go to your dealer for service.

**To reset the tripmeter A fuel consumption:** → P.30

## Average Speed [AVG. SPD.]

Displays average speed since the engine was started.

Display range: 0 to 186 mph (0 to 299 km/h)

- Initial display: "---" is displayed.
- When your motorcycle has traveled less than 0.12 mile (0.2 km) since the engine was started: "---" is displayed.
- When your motorcycle operating time is less than 16 seconds since the engine was started: "---" is displayed.

AVG. SPD.  
35 mph

When "---" is displayed except for the above-mentioned cases, go to your dealer for service.

## Instruments *(Continued)*

### Elapsed time [ELAPSED]

Displays operating time since the engine was started.

Display range: 00:00 to 99:59 (hours:minutes)

- Above 99:59: returns to 00:00.

When the ignition switch is turned to the OFF position, the elapsed time is reset.



ELAPSED  
01:30

When "--:--" is displayed, go to your dealer for service.

### Available driving distance [RANGE] (Only reserve fuel mode)

When the low fuel indicator lights and the low fuel pop-up information appears, the estimated available driving distance is indicated.

Display range: 99 to 0 mile (km)

- Above 99 mile (km): "99" is displayed.
- Below 0.2 GAL (1.0 L): "--" is displayed.

The indicated available driving distance is calculated based on the driving states, and the indicated figure may not always be the actual allowable distance.



RANGE  
20 mile

When "--" is displayed except for the above-mentioned cases, go to your dealer for service.

## Amount of remaining fuel [REMAIN] (Only reserve fuel mode)

When the low fuel indicator lights and the low fuel pop-up information appears, the estimated amount of remaining fuel can be selected.

Display range: 0.9 to 0.2 GAL (gallon) or 4.0 to 1.0 L (liters)

- Below 0.2 GAL (1.0 L): "-.-" is displayed.

The amount of remaining fuel is calculated based on the driving states.

The indicated amount of remaining fuel may be different from the actual amount.



REMAIN  
0.6 GAL

When "-.-" is displayed except for the above-mentioned cases, go to your dealer for service.

## Instruments *(Continued)*

### Reserve Fuel Mode

When the low fuel indicator lights and the low fuel pop-up information appears, the available driving distance is indicated, and the amount of remaining fuel display can be selected.

You should refill the tank as soon as possible.

Remaining fuel amount turned to the reserve fuel mode:

1.1 US gal (4.0 L)

### Low fuel pop-up information

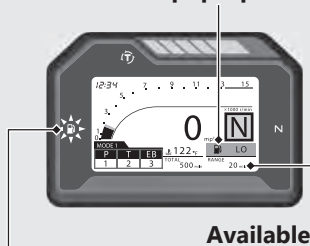

**Low fuel indicator**

**Available driving distance**

After refueling more than the reserve amount, the display returns to normal when the ignition switch has been ON position for about a minute.



## INFO 3 display

You can select the following:

- CBR Logo
- Shift indicator set value [REV IND NE]
- Throttle grip angle [GRIP ANGLE]
- Battery voltage [VOLTAGE]
- Date [DATE]
- User letter
- Blank display

## Changing the INFO 3 display

- 1 Select the INFO 3 display. **➔ P.27**
- 2 Press the **SEL ▲** (up) or **SEL ▼** (down) button until the desired display is displayed.
- 3 Press the **MODE** button. The INFO 3 display is set, and then the display moves to the riding mode display.

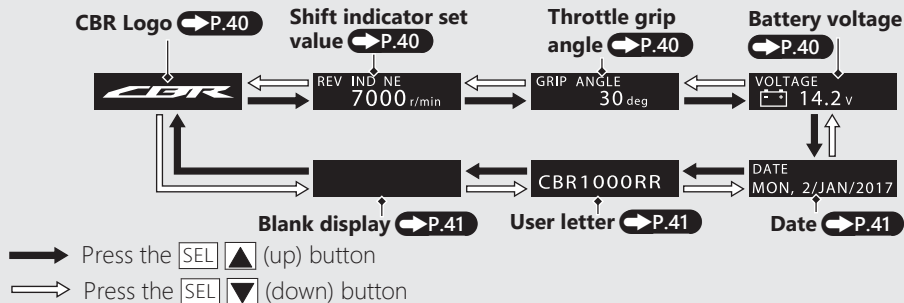

## Instruments *(Continued)*

### CBR logo

Displays the CBR logo.



### Shift indicator set value [REV IND NE]

Displays the shift indicator set value.

Display range: OFF or 4,000 to 16,600 r/min



To set the shift indicator:  P.61

### Throttle grip angle [GRIP ANGLE]

Displays the throttle grip angle during operation.



When "--" is displayed, go to your dealer for service.

### Battery voltage [VOLTAGE]

Displays the current voltage.



**Date [DATE]**

Displays the today's date.

Display range:

Day of the week: MON to SUN

DAY: 1 to 31

Month: JAN to DEC

Year: 2010 to 2099

DATE  
MON, 2/JAN/2017

**To set the Date:**  P.70

**User letter**

Displays the characters of user's choice.

CBR 1000RR

**To set the USER LETTER:**  P.64

**Blank display**

Display the blank.





## Instruments *(Continued)*

### Setting mode



You can perform the following:



- **FUNCTION** ➔ **P.45**
  - ⌋ **CBR1000S1**  
Setting the Quick Shifter
  - ⌋ **CBR1000S1**  
Setting the suspension
- **LAP TIME** ➔ **P.55**
  - ⌋ Checking the lap time
  - ⌋ Resetting the lap time
- **DISPLAY** ➔ **P.58**
  - ⌋ Changing the display mode
  - ⌋ Setting the shift indicator
  - ⌋ Setting the backlight brightness
  - ⌋ Setting the back ground
  - ⌋ Setting the user letter
  - ⌋ Setting the favorite
- **GENERAL** ➔ **P.69**
  - ⌋ Setting the date and clock
  - ⌋ Setting each meter unit
  - ⌋ Resetting to factory default settings
- **SERVICE** ➔ **P.79**
  - ⌋ Checking the next inspection schedule
  - ⌋ **CBR1000S1**  
SUSPENSION  
"EQUIPMENT" is displayed but not selectable.
  - ⌋ **CBR1000S1**  
Quick Shifter  
"INITIALIZE" and "EQUIPMENT" are displayed but not selectable.
  - ⌋ Checking the current problem with the PGM-FI system.  
**CBR1000S1**  
Checking the current problem with the ÖHLINS Smart EC system.
  - ⌋ "SPORTS KIT ECU USAGE" is displayed but not usable.
- **SPORTS KIT** (Not selectable)



## To Shift to the Setting Mode

Press and hold the **MODE** button and **SEL**  (up) or **SEL**  (down) button until main menu screen is displayed with your motorcycle stopped.

### Main menu screen

12:34		SETTING	0 mph
SPORTS KIT	HISS INDICATOR	DOWN LVL	
EXIT			
FUNCTION	QUICKSHIFTER	UP	
LAP TIME	SUSPENSION A1	DOWN	
DISPLAY	SUSPENSION A2	UP LVL	

Select a menu by pressing the **SEL**  (up) or **SEL**  (down) button and press the **MODE** button.

- ↳ Press and hold the **SEL**  (up) or **SEL**  (down) button to move the menu quickly.

## Instruments (Continued)

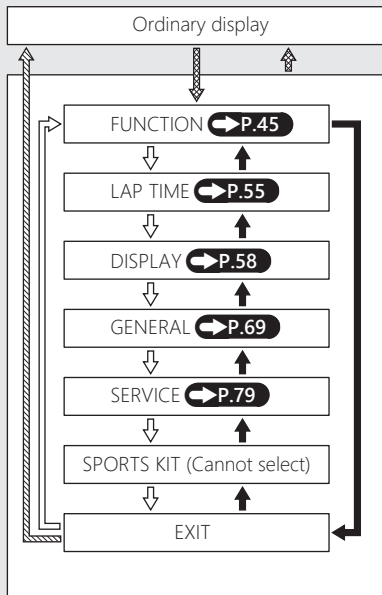

→ Press the **MODE** button

→ Press and hold the **MODE** button and **SEL ▲** (up) or **SEL ▼** (down) button

→ Press the **SEL ▲** (up) button

→ Press the **SEL ▼** (down) button

### To End the Setting

Select the "EXIT" menu on the main menu screen, or press and hold the **MODE** button and **SEL ▲** (up) or **SEL ▼** (down) button. Also, the setting mode is ended when your motorcycle speed reaches approximately 1 km/h (1 mph).

↳ Press and hold the **MODE** button and **SEL ▲** (up) or **SEL ▼** button to return to the ordinary display.

Note that doing so cancels the settings left incomplete.

## FUNCTION

### To Set the FUNCTION Menu

- 1 Select the "FUNCTION" menu on the main menu screen. P.43
- 2 Select a menu by pressing the (up) or (down) button and press the button.

### To End the Setting

Select the (return) on the menu screen. The display returns to the "FUNCTION" menu on the main menu screen.

- Press the button
- Press the (up) button
- Press the (down) button

### "FUNCTION" is selected

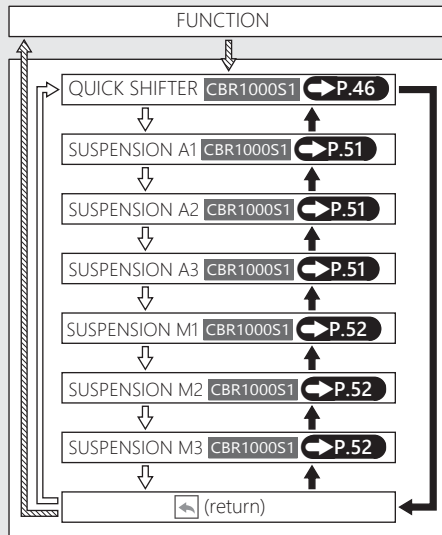

## Instruments *(Continued)*

### QUICK SHIFTER

CBR1000S1

You can change the setting of the Quick Shifter.

- UP:  
To select "ON" (activate) or "OFF" (deactivate) for upshifting ➡P.47
- DOWN:  
To select "ON" (activate) or "OFF" (deactivate) for downshifting ➡P.48
- UP LVL:  
To select the shift pedal load level for activating the Quick Shifter when upshifting ➡P.49
- DOWN LVL:  
To select the shift pedal load level for activating the Quick Shifter when downshifting ➡P.50

### To End the Setting





Select the  (return) on the menu screen. The display returns to the "QUICKSHIFTER" menu on the "FUNCTION" screen.

### To use the Quick Shifter ➡P.110





## UP

You can select "ON" (activate) or "OFF" (deactivate) for upshifting with the Quick Shifter.

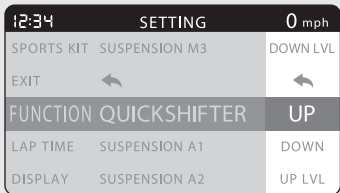
- 1 Select the "UP" using the **SEL**  (up) or **SEL**  (down) button, and press the **MODE** button.
  - ↳ Press and hold the **SEL**  (up) or **SEL**  (down) button to move the menu quickly.



- 2 Select "ON" (activate) or "OFF" (deactivate) using the **SEL**  (up) or **SEL**  (down) button.

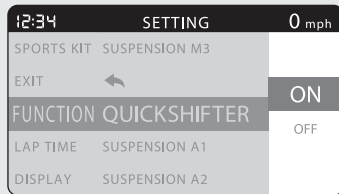





- 3 Press the **MODE** button. The "UP" setting is set, and then the display returns to the upper level hierarchy.



## Instruments *(Continued)*

### DOWN

You can select "ON" (activate) or "OFF" (deactivate) for downshifting with the Quick Shifter.

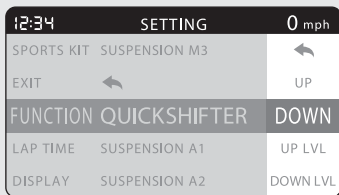
- Select the "DOWN" using the **SEL**  (up) or **SEL**  (down) button, and press the **MODE** button.
  - Press and hold the **SEL**  (up) or **SEL**  (down) button to move the menu quickly.





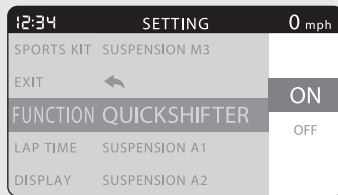

- Select "ON" (activate) or "OFF" (deactivate) using the **SEL**  (up) or **SEL**  (down) button.









- Press the **MODE** button. The "DOWN" setting is set, and then the display returns to the upper level hierarchy.



## UP LVL

You can select the shift pedal load level for activating the Quick Shifter when upshifting.

- 1 Select the "UP LVL" using the **SEL**  (up) or **SEL**  (down) button, and press the **MODE** button.
  - ↳ Press and hold the **SEL**  (up) or **SEL**  (down) button to move the menu quickly.

12:34		SETTING	0 mph
SPORTS KIT	SUSPENSION M3	UP	
EXIT		DOWN	
FUNCTION QUICKSHIFTER		UP LVL	
LAP TIME	SUSPENSION A1	DOWN LVL	
DISPLAY	SUSPENSION A2		

- 2 Select one of the three levels using the **SEL**  (up) or **SEL**  (down) button.
  - ↳ Press and hold the **SEL**  (up) or **SEL**  (down) button to move the menu quickly.
  - ↳ Available setting range: 1 (light operation) to 3 (heavy operation)

12:34		SETTING	0 mph
SPORTS KIT	SUSPENSION M3		
EXIT		1	
FUNCTION QUICKSHIFTER		2	
LAP TIME	SUSPENSION A1	3	
DISPLAY	SUSPENSION A2		

- 3 Press the **MODE** button. The "UP LVL" setting is set, and then the display returns to the upper level hierarchy.

## Instruments (Continued)

### DOWN LVL

You can select the shift pedal load level for activating the Quick Shifter when downshifting.

- 1 Select the "DOWN LVL" using the **[SEL]** **▲** (up) or **[SEL]** **▼** (down) button, and press the **[MODE]** button.
  - ↳ Press and hold the **[SEL]** **▲** (up) or **[SEL]** **▼** (down) button to move the menu quickly.

12:34		SETTING	0 mph
SPORTS KIT	SUSPENSION M3	DOWN	
EXIT	←	UP LVL	
FUNCTION QUICKSHIFTER		DOWN LVL	
LAP TIME	SUSPENSION A1	←	
DISPLAY	SUSPENSION A2	UP	

- 2 Select one of the three levels using the **[SEL]** **▲** (up) or **[SEL]** **▼** (down) button.
  - ↳ Press and hold the **[SEL]** **▲** (up) or **[SEL]** **▼** (down) button to move the menu quickly.
  - ↳ Available setting range: 1 (light operation) to 3 (heavy operation)

12:34		SETTING	0 mph
SPORTS KIT	SUSPENSION M3		
EXIT	←	1	
FUNCTION QUICKSHIFTER		2	
LAP TIME	SUSPENSION A1	3	
DISPLAY	SUSPENSION A2	←	

- 3 Press the **[MODE]** button. The "DOWN LVL" setting is set, and then the display returns to the upper level hierarchy.

## SUSPENSION A1, A2 and A3

CBR1000S1

You can change the levels of OBTi support items.

### Adjusting the ÖHLINS Smart EC system





➔ P.170

#### To End the Setting

Select the  (return) on the menu screen. The display returns to the "SUSPENSION A1", "SUSPENSION A2" or "SUSPENSION A3" menu on the "FUNCTION" screen.



## BRAKE, ACC (SUSPENSION A1 only), CORNER (SUSPENSION A1 only) and GENERAL

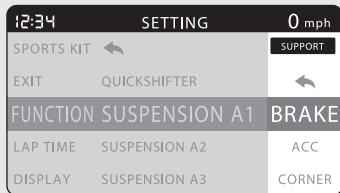

You can select the "DEFAULT" or one of the ten suspension damping levels for damping characteristics of the suspension.

- 1 Select the item you want to change using the  (up) or  (down) button, and press the  button.
  - ↳ Press and hold the  (up) or  (down) button to move the menu quickly.



## Instruments (Continued)

- Select the "DEFAULT" or one of the ten suspension damping levels using the **SEL**  (up) or **SEL**  (down) button.

  - Press and hold the **SEL**  (up) or **SEL**  (down) button to move the menu quickly.
  - Available setting range:  
-5 to +5

SETTING		0 mph
SPORTS KIT		+3
EXIT	QUICKSHIFTER	+2
		+1
FUNCTION	SUSPENSION A1	DEFAULT
LAP TIME	SUSPENSION A2	-1
DISPLAY	SUSPENSION A3	-2
		-3

- Press the **MODE** button. The selected item is set, and then the display returns to the upper level hierarchy.

## SUSPENSION M1, M2 and M3

CBR1000S1

You can adjust the compression and rebound damping of the front and rear suspension electronically.

### Adjusting the ÖHLINS Smart EC system





 P.170

#### To End the Setting





Select the  (return) on the menu screen. The display returns to the "SUSPENSION M1", "SUSPENSION M2" or "SUSPENSION M3" menu on the "FUNCTION" screen.

## FR COMP, FR REB, RR COMP and RR REB

You can select one of the 21 different damping levels for the front and rear suspension.

- Select the item you want to change using the **SEL**  (up) or **SEL**  (down) button, and press the **MODE** button.
  - Press and hold the **SEL**  (up) or **SEL**  (down) button to move the menu quickly.

12:34		SETTING	0 mph
SPORTS KIT	SUSPENSION A2	RR REB	
EXIT	SUSPENSION A3		
FUNCTION	SUSPENSION M1	FR COMP	
LAP TIME	SUSPENSION M2	FR REB	
DISPLAY	SUSPENSION M3	RR COMP	

- Adjust to one of the 21 damping levels using the **SEL**  (up) or **SEL**  (down) button.
  - Press and hold the **SEL**  (up) or **SEL**  (down) button to move the menu quickly.
  - Available setting: MIN (soft), MAX (hard), and the range 5% - 95% in 5% increments

12:34		SETTING	0 mph
SPORTS KIT	SUSPENSION A2	ADJ. RANGE	50
EXIT	SUSPENSION A3		55
FUNCTION	SUSPENSION M1		60 %
LAP TIME	SUSPENSION M2		65
DISPLAY	SUSPENSION M3		70
			75

## Instruments (Continued)

Preset settings are as follows.

	Front		Rear	
	Compression FR COM	Rebound FR REB	Compression RR COM	Rebound RR REB
M1	45%	30%	60%	50%
M2	20%	25%	50%	45%
M3	10%	10%	25%	30%

- 3 Press the **MODE** button. The selected the item setting is set, and then the display returns to the upper level hierarchy.



## LAP TIME

### To Set the LAP TIME Menu

- 1 Select the "LAP TIME" menu on the main menu screen. ➔ P.43
- 2 Select the menu by pressing the **SEL** **▲** (up) or **SEL** **▼** (down) button, and press the **MODE** button.

### To End the Setting

Select the **◀** (return) on the menu screen. The display returns to the "LAP TIME" menu on the main menu screen.

### "LAP TIME" is selected

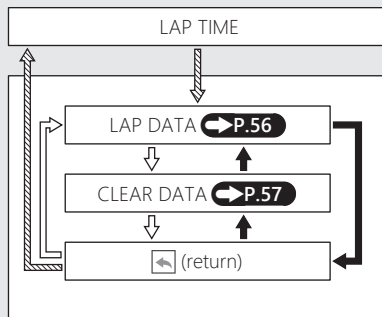

- ➔ Press the **MODE** button
- ➔ Press the **SEL** **▲** (up) button
- ➔ Press the **SEL** **▼** (down) button

## Instruments (Continued)

### LAP DATA

The history of recorded lap time and information are displayed.

To display the other lap information, press the **[SEL]** **▲** (up) or **[SEL]** **▼** (down) button.

To display the maximum acceleration, maximum deceleration, maximum left bank

angle and maximum right bank angle information, press the **[LAP]** button.



To end the display of lap time history, press the **[MODE]** button. The display returns to the upper level hierarchy.

**To use the Lap Timer** **P.86**

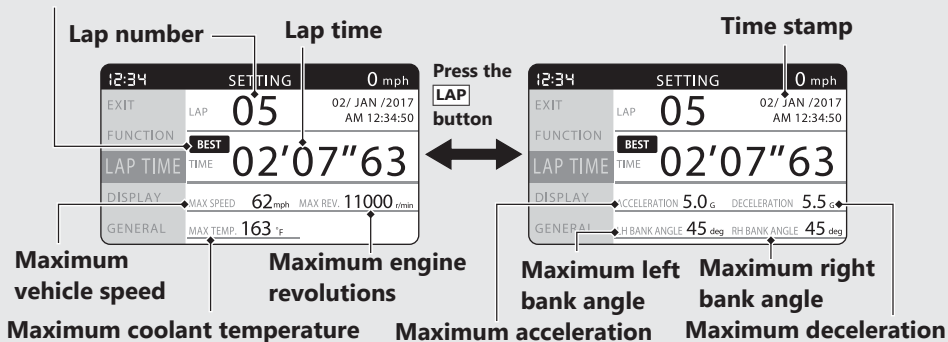
### Best icon (Appears when the fastest lap time displayed.)



## CLEAR DATA

- 1 Select "NO" (not clear) or "YES" (clear) using the **SEL**  (up) or **SEL**  (down) button.
- 2 Press the **MODE** button. The display returns to the upper level hierarchy.

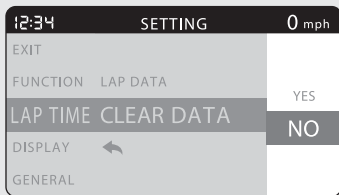

To use the Lap Timer  P.86

## Instruments *(Continued)*

### DISPLAY

#### To Set the DISPLAY Menu

- 1 Select the "DISPLAY" menu on the main menu screen. **➡P.43**
- 2 Select the menu by pressing the **SEL** **▲** (up) or **SEL** **▼** (down) button and press the **MODE** button.

#### To End the Setting

Select the **◀** (return) on the menu screen. The display returns to the "DISPLAY" menu on the main menu screen.

**➡** Press the **MODE** button



**➡** Press the **SEL** **▲** (up) button

**➡** Press the **SEL** **▼** (down) button

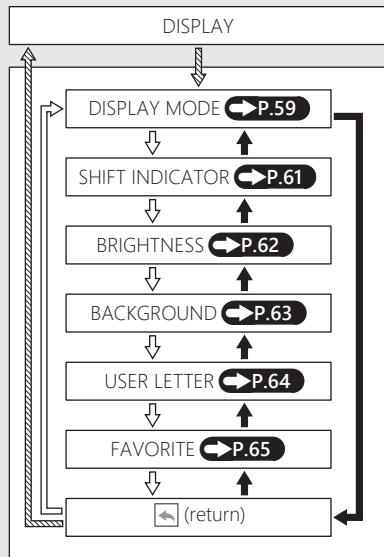
#### "DISPLAY" is selected



## DISPLAY MODE

- 1 Select "STREET", "MECHANIC" or "CIRCUIT" using the **SEL**  (up) or **SEL**  (down) button.

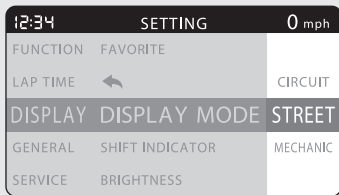

- 2 When the "STREET" or "CIRCUIT" is selected  
Press the **MODE** button. The display mode setting is set, and then the display returns to the upper level hierarchy.  
When the "MECHANIC" is selected  
Press the **MODE** button. The display moves to the mechanic mode.

- 3 When the "MECHANIC" is selected  
Press the **MODE** button. The mechanic mode ends, and then the display returns to the upper level hierarchy.  
↳ The display mode returns to the previously selected mode.

## Instruments (Continued)

### Mechanic Mode

Displays the current information of the motorcycle.

Displays the following information:



- Tachometer
- Gear position
- Throttle grip position
- Coolant temperature
- Battery voltage

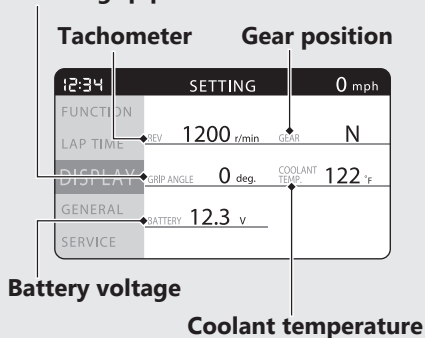

### Throttle grip position



## SHIFT INDICATOR

You can change the setting of the shift indicators.

- Select the "OFF" (deactivate) or an engine revolution at which the shift indicators start blinking using the **SEL**  (up) or **SEL**  (down) button.

  - Press and hold the **SEL**  (up) or **SEL**  (down) button to move the menu quickly.
  - The value increases by 200 r/min (rpm) increments.
  - Available setting range:  
4,000 to 16,600 r/min (rpm)
- Press the **MODE** button. The shift indicator setting is set, and then the display returns to the upper level hierarchy.

12:34		SETTING	0 mph
FUNCTION			16400
LAP TIME	DISPLAY MODE		16600
			OFF
DISPLAY	SHIFT INDICATOR		4000 <small>r/min</small>
GENERAL	BRIGHTNESS		4200
			4400
SERVICE	BACKGROUND		4600

### Information of the Shift Indicator:





 P.96

## Instruments (Continued)

### BRIGHTNESS

You can adjust the backlight brightness to one of the eight levels or select the auto adjustment.

#### Automatic Brightness Control P.203



- 1 Select the "AUTO" (auto adjustment) or brightness level using the **SEL**  (up) or **SEL**  (down) button.
  - ↳ Press and hold the **SEL**  (up) or **SEL**  (down) button to move the menu quickly.
- 2 Press the **MODE** button. The backlight brightness setting is set, and then the display returns to the upper level hierarchy.



12:34		SETTING	0 mph
FUNCTION	DISPLAY MODE		6
LAP TIME	SHIFT INDICATOR		7
			8
<b>DISPLAY</b>	<b>BRIGHTNESS</b>		<b>AUTO</b>
GENERAL	BACKGROUND		1
			2
SERVICE	USER LETTER		3



## BACKGROUND

You can change the setting of the background to one of the four categories or select the auto adjustment.

- 1 Select the "AUTO", "WHITE", "BLACK", "METALLIC" or "CARBON" using the **SEL**  (up) or **SEL**  (down) button.

  - ↳ Press and hold the **SEL**  (up) or **SEL**  (down) button to move the menu quickly.
- 2 Press the **MODE** button. The background setting is set, and then the display returns to the upper level hierarchy.

12:34	SETTING	0 km/h
FUNCTION	SHIFT INDICATOR	METALLIC
LAP TIME	BRIGHTNESS	CARBON
DISPLAY	BACKGROUND	AUTO
GENERAL	USER LETTER	WHITE
SERVICE	FAVORITE	BLACK

## Instruments (Continued)

### USER LETTER

You can select any 10 characters you like.

- 1 Select the first character using the **SEL** **▲** (up) or **SEL** **▼** (down) button until a desired character appears
  - ↳ Press and hold the **SEL** **▲** (up) or **SEL** **▼** (down) button to move the menu quickly.
- 2 Press the **MODE** button. The cursor moves to the next position.
- 3 Repeat the steps 1 and 2 to select characters for the other positions until a desired word is complete..
- 4 When the tenth character is selected, the display returns to the upper level hierarchy.

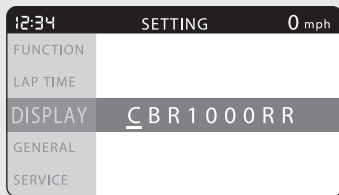

#### A list of characters that can be selected

<b>A</b>	<b>B</b>	<b>C</b>	<b>D</b>	<b>E</b>	<b>F</b>	<b>G</b>	<b>H</b>	<b>I</b>
<b>J</b>	<b>K</b>	<b>L</b>	<b>M</b>	<b>N</b>	<b>O</b>	<b>P</b>	<b>Q</b>	<b>R</b>
<b>S</b>	<b>T</b>	<b>U</b>	<b>V</b>	<b>W</b>	<b>X</b>	<b>Y</b>	<b>Z</b>	<b>0</b>
<b>1</b>	<b>2</b>	<b>3</b>	<b>4</b>	<b>5</b>	<b>6</b>	<b>7</b>	<b>8</b>	<b>9</b>
<b>!</b>	<b>"</b>	<b>#</b>	<b>\$</b>	<b>%</b>	<b>&amp;</b>	<b>'</b>	<b>'</b>	<b>(</b>
<b>)</b>	<b>*</b>	<b>+</b>	<b>,</b>	<b>-</b>	<b>.</b>	<b>/</b>	<b>:</b>	<b>;</b>
<b>&lt;</b>	<b>&gt;</b>	<b>=</b>	<b>?</b>	<b>@</b>	<b>^</b>	<b>_</b>		

## FAVORITE

You can change the indications on the INFO 1, INFO 2, and INFO 3 to the following information by pressing the **LAP** button while the street mode is displayed.

INFO 1:

"TOTAL", "TRIP A" or "TRIP B"

INFO 2:

"REV", "INST.CONST.", "AVG.CONST.", "TRIP A  
CONST.", "AVG.SPD." or "ELAPSED"

INFO 3:

"CBR LOGO", "REV IND NE", "GRIP ANGLE",  
"VOLTAGE", "DATE", "USER LETTER" or a  
blank display





## To End the Setting

Select the  (return) on the menu screen.  
The display returns to the "FAVORITE" menu  
on the "DISPLAY" menu screen.





## Instruments *(Continued)*

### INFO 1

You can select the "TOTAL", "TRIP A" or "TRIP B" for INFO 1.

- 1 Select the "INFO 1" using the **SEL**  (up) or **SEL**  (down) button, and press the **MODE** button.
  - ↳ Press and hold the **SEL**  (up) or **SEL**  (down) button to move the menu quickly.

12:34	SETTING	0 mph
FUNCTION	BACKGROUND	
LAP TIME	USER LETTER	
DISPLAY	FAVORITE	INFO 1
GENERAL		INFO 2
SERVICE	DISPLAY MODE	INFO 3





- 2 Select the "TOTAL", "TRIP A" or "TRIP B" using the **SEL**  (up) or **SEL**  (down) button.
  - ↳ Press and hold the **SEL**  (up) or **SEL**  (down) button to move the menu quickly.

12:34	SETTING	0 mph
FUNCTION	BACKGROUND	
LAP TIME	USER LETTER	TRIP B
DISPLAY	FAVORITE	TOTAL
GENERAL		TRIP A
SERVICE	DISPLAY MODE	





- 3 Press the **MODE** button. The "INFO 1" setting is set, and then the display returns to the upper level hierarchy.

## INFO 2

You can select the "REV", "INST.CON.S.", "AVG.CON.S.", "TRIP A CON.S.", "AVG.SPD." or "ELAPSED" for INFO 2.

- 1 Select the "INFO 2" using the **SEL**  (up) or **SEL**  (down) button, and press the **MODE** button.
  - ↳ Press and hold the **SEL**  (up) or **SEL**  (down) button to move the menu quickly.

12:34		SETTING	0 km/h
FUNCTION	BACKGROUND		
LAP TIME	USER LETTER		INFO 1
DISPLAY FAVORITE			INFO 2
GENERAL			INFO 3
SERVICE	DISPLAY MODE		

- 2 Select the "REV", "INST.CON.S.", "AVG.CON.S.", "TRIP A CON.S.", "AVG.SPD." or "ELAPSED" using the **SEL**  (up) or **SEL**  (down) button.
  - ↳ Press and hold the **SEL**  (up) or **SEL**  (down) button to move the menu quickly.

12:34		SETTING	0 mph
FUNCTION	BACKGROUND		AVG.SPD.
LAP TIME	USER LETTER		ELAPSED
DISPLAY FAVORITE			REV
GENERAL			INST.CON.S.
SERVICE	DISPLAY MODE		AVG.CON.S.

- 3 Press the **MODE** button. The "INFO 2" setting is set, and then the display returns to the upper level hierarchy.

## Instruments (Continued)

### INFO 3

You can select the "CBR LOGO", "REV IND NE", "GRIP ANGLE", "VOLTAGE", "DATE", "USER LETTER" or blank display for INFO 3.

- 1 Select the "INFO 3" using the **SEL** ▲ (up) or **SEL** ▼ (down) button, and press the **MODE** button.
  - ↳ Press and hold the **SEL** ▲ (up) or **SEL** ▼ (down) button to move the menu quickly.

12:34		SETTING	0 mph
FUNCTION	BACKGROUND		
LAP TIME	USER LETTER		INFO 2
<b>DISPLAY FAVORITE</b>			<b>INFO 3</b>
GENERAL	←		←
SERVICE	DISPLAY MODE		INFO 1

- 2 Select the "CBR LOGO", "REV IND NE", "GRIP ANGLE", "VOLTAGE", "DATE", "USER LETTER" or blank display using the **SEL** ▲ (up) or **SEL** ▼ (down) button.
  - ↳ Press and hold the **SEL** ▲ (up) or **SEL** ▼ (down) button to move the menu quickly.

12:34		SETTING	0 mph
FUNCTION	BACKGROUND		USER LETTER
LAP TIME	USER LETTER		
<b>DISPLAY FAVORITE</b>			<b>CBR LOGO</b>
GENERAL	←		REV IND NE
SERVICE	DISPLAY MODE		GRIP ANGLE

- 3 Press the **MODE** button. The "INFO 3" setting is set, and then the display returns to the upper level hierarchy.

## GENERAL

### To Set the GENERAL Menu

- 1 Select the "GENERAL" on the main menu screen. **➡ P.43**
- 2 Select a menu by pressing the **SEL ▲** (up) or **SEL ▼** (down) button and press the **MODE** button.

### To End the Setting

Select the **↩** (return) menu on the menu screen. The display returns to the "GENERAL" on the main menu screen.

### "GENERAL" is selected

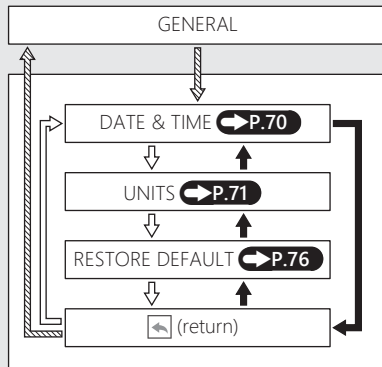

➡ Press the **MODE** button

➡ Press the **SEL ▲** (up) button

➡ Press the **SEL ▼** (down) button

## Instruments *(Continued)*

### DATE & TIME

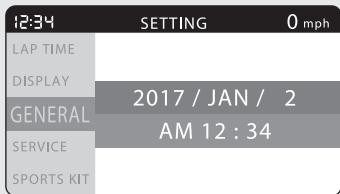

- 1 Press the **SEL** **▲** (up) or **SEL** **▼** (down) button until the desired tens digit of the year is displayed.
- 2 Press the **MODE** button. The cursor moves to the ones digit of the year.



- 3 Press the **SEL** **▲** (up) or **SEL** **▼** (down) button until the desired ones digit of the year is displayed.

- 4 Press the **MODE** button. The cursor moves to the indication of month.
- 5 Press the **SEL** **▲** (up) or **SEL** **▼** (down) button until the desired month is displayed.
- 6 Press the **MODE** button. The cursor moves to the indication of date.
- 7 Press the **SEL** **▲** (up) or **SEL** **▼** (down) button until the desired date is displayed.
- 8 Press the **MODE** button. The cursor moves to the "AM" or "PM".
- 9 Select the "AM" or "PM" using the **SEL** **▲** (up) or **SEL** **▼** (down) button.
- 10 Press the **MODE** button. The cursor moves to the indication of hour.
- 11 Press the **SEL** **▲** (up) or **SEL** **▼** (down) button until the desired hour is displayed.





- 12 Press the **MODE** button. The cursor moves to the indication of minute.
- 13 Press the **SEL**  (up) or **SEL**  (down) button until the desired minute is displayed.
- 14 Press the **MODE** button. The date and clock setting is set, and then the display returns to the upper level hierarchy.

Press and hold the **SEL**  (up) or **SEL**  (down) button to move the menu quickly.

## UNITS

You can change the speed and mileage, temperature, and fuel mileage meter units.

### To Set Each Unit

- 1 Select the "SPEED", "TEMP." or "FUEL CONS." using the **SEL**  (up) or **SEL**  (down) button.
- 2 Press the **MODE** button. The display moves to each unit setting screen.

The units of the speedometer, odometer, tripmeter A/B, current fuel mileage, average fuel mileage, tripmeter A fuel consumption, average speed, available driving distance and amount of remaining fuel are changed in "SPEED" menu.

## Instruments *(Continued)*

The unit of coolant temperature gauge and information of temperature (lap data history mode and mechanic mode) is changed by "TEMP." menu.

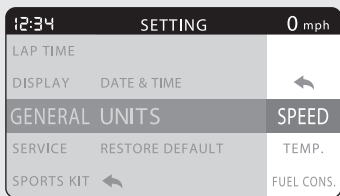

The units of the current fuel mileage, average fuel mileage and amount of remaining fuel are changed in "FUEL CONS." menu.



## To End the Setting

Select the  (return) on the menu screen. The display returns to the "UNITS" menu on the "GENERAL" menu screen.

## Speed and Mileage Unit [SPEED]

- 1 Select the "mph" or "km/h" using the **SEL**  (up) or **SEL**  (down) button.
- 2 Press the **MODE** button. The speed and mileage unit setting is set, and then the display returns to the upper level hierarchy.



When selecting the "mph"

- Units of the speedometer and average speed show "mph".
- Units of the odometer, tripmeter A/B and available driving distance show "mile".
- Units of the current fuel mileage and average fuel mileage show "MPG" or "mile/L".
- Units of the tripmeter A fuel consumption and amount of remaining fuel show "GAL" or "L".

## Instruments *(Continued)*

When selecting the "km/h"

- Units of the speedometer and average speed show "km/h".
- Units of the odometer, tripmeter A/B and available driving distance show "km".
- Units of the current fuel mileage and average fuel mileage show "L/100km" or "km/L".
- Units of the tripmeter A fuel consumption and amount of remaining fuel show "L".

## Temperature Unit [TEMP.]

- 1 Select the "°F" or "°C" using the **[SEL]** **[▲]** (up) or **[SEL]** **[▼]** (down) button.
- 2 Press the **[MODE]** button. The temperature unit setting is set, and then the display returns to the upper level hierarchy.



## Fuel Mileage Meter Unit [FUEL CONS.]

- 1 When the "mph" of the "SPEED" menu is selected

Select the "MPG" or "mile/L" using the **SEL** **▲** (up) or **SEL** **▼** (down) button.

When the "km/h" of the "SPEED" menu is selected

Select the "L/100 km" or "km/L" using the **SEL** **▲** (up) or **SEL** **▼** (down) button.

- 2 Press the **MODE** button. The fuel mileage meter unit setting is set, and then the display returns to the upper level hierarchy.



When selecting the "MPG"

- Units of the current fuel mileage and average fuel mileage show "MPG".
- Units of the tripmeter A fuel consumption and amount of remaining fuel show "GAL".

When selecting the "mile/L"

- Units of the current fuel mileage and average fuel mileage show "mile/L".
- Units of the tripmeter A fuel consumption and amount of remaining fuel show "L".

## Instruments *(Continued)*

When selecting the "L/100 km"



- Units of the current fuel mileage and average fuel mileage show "L/100 km".
- Units of the tripmeter A fuel consumption and amount of remaining fuel show "L".

When selecting the "km/L"

- Units of the current fuel mileage and average fuel mileage show "km/L".
- Units of the tripmeter A fuel consumption and amount of remaining fuel show "L".

## RESTORE DEFAULT

The set value can be returned to default setting.

- 1 Select the "NO" (not restore) or "YES" (restore) using the **SEL**  (up) or **SEL**  (down) button.

### 2 When the "NO" is selected

Press the **MODE** button. The set value is maintained, and then the display returns to the upper level hierarchy.

### When the "YES" is selected

Press the **MODE** button. The display changes to the confirmation screen.



- 3 Select the "NO" (not restore) or "YES" (restore) using the the **SEL** **▲** (up) or **SEL** **▼** (down) button on the confirmation screen.

- 4 When the "NO" is selected Press the **MODE** button. The set value is maintained, and then the display returns to the "RESTORE DEFAULT" menu on the "GENERAL" menu screen.

**When the "YES" is selected**

Press the **MODE** button. The set value return to default setting.

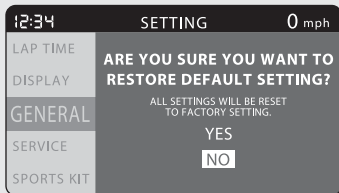

- 5 Select the "EXIT" by pressing the **MODE** button.



- 6 The display returns to the "RESTORE DEFAULT" menu on the "GENERAL" menu screen.

## Instruments (Continued)

Default setting values:

- LAP DATA: Cleared
- DISPLAY MODE: STREET
- SHIFT INDICATOR: OFF
- BRIGHTNESS: AUTO
- BACK GROUND: AUTO
- USER LETTER: CBR1000RR
- FAVORITE: TOTAL, REV, CBR LOGO
- SPEED UNIT: USA mph (Canada km/h)
- TEMP UNIT: USA °F (Canada °C)
- FUEL CONS UNIT: USA MPG (Canada L/100km)
- **CBR1000S1**  
QUICK SHIFTER: OFF (Quick Shifter system is disabled.)
- **CBR1000S1**  
SUSPENSION A1, A2, A3: Default setting  
➔P.51

- **CBR1000S1**  
SUSPENSION M1, M2, M3: Preset setting  
➔P.54
- Riding mode: USER 1 and USER 2 setting value returns to initial setting values.  
➔P.102



## SERVICE

### To Set the SERVICE Menu

- 1 Select the "SERVICE" menu on the main menu screen. ➡ P.43
- 2 Select the menu by pressing the [SEL] ▲ (up) or [SEL] ▼ (down) button and press the [MODE] button.

▨➡ Press the [MODE] button

➡ Press the [SEL] ▲ (up) button

↩➡ Press the [SEL] ▼ (down) button

### "SERVICE" is selected

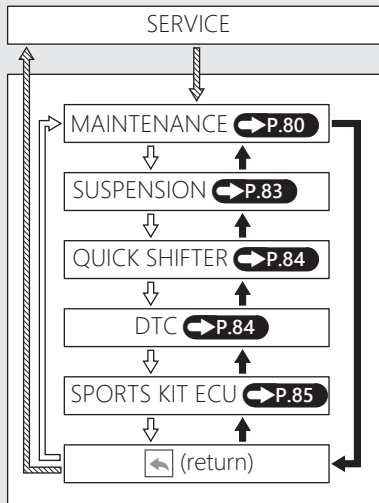



## Instruments *(Continued)*

### To End the Setting

Select the  (return) on the menu screen, and then the display returns to the "SERVICE" menu on the main menu screen.

## MAINTENANCE

You can check the next inspection time and change the setting of next inspection.

12:34		SETTING		0 mph	
DISPLAY		DISTANCE		DATE	
GENERAL		- 500	mile	JUL / 2017	
SERVICE		- 500	mile	JUL / 2017	
SPORTS KIT					
EXIT					

**Next engine oil change**  
**Next periodic inspection**

To return to the upper level hierarchy, press the  button.

Display range:

DISTANCE:

Next periodic inspection:

-8000 to +99950 mile

(-12000 to +99900 km)

Next engine oil change:

-4000 to +99980 mile

(-6000 to +99980 km)

□ Pass 0 mile (km): "-" mark changed to

"+" mark

DATE:

Month: JAN to DEC

Year: 2010 to 2099

- "-300 mile" or "-500 km" from the next periodic inspection
- "-60 mile" or "-100 km" from the next engine oil change
- One month before the set month

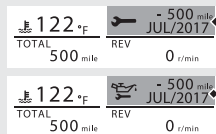





**Maintenance  
pop-up  
information**

When reaching any of the following, the pop-up information is appears in the ordinary display. **P.90**



## Instruments (Continued)

### Next inspection setting

- 1 Select “” (periodic inspection) or “” (engine oil change) using the **[SEL]** **[▲]** (up) or **[SEL]** **[▼]** (down) button.

12:34		SETTING		0 mph
DISPLAY		DISTANCE	DATE	
GENERAL		- 500	mile	JUL / 2017
SERVICE		- 500	mile	JUL / 2017
SPORTS KIT				
EXIT				

- 2 Press and hold the **[MODE]** button until the “DISTANCE” value start flashing.

12:34		SETTING		0 mph
DISPLAY		DISTANCE	DATE	
GENERAL		- 500	mile	JUL / 2017
SERVICE		- 500	mile	JUL / 2017
SPORTS KIT				
EXIT				

- 3 Press the **[SEL]** **[▲]** (up) or **[SEL]** **[▼]** (down) button until the desired distance value is displayed.
  - ⌋ Available setting range of periodic inspection:  
100 to 4,000 mile (100 to 6,400 km)
  - ⌋ Available setting range of engine oil change:  
100 to 8,000 mile (100 to 12,800 km)

- 4 Press the **MODE** button. The cursor moves to the indication of month.
- 5 Press the **SEL** **▲** (up) or **SEL** **▼** (down) button until the desired month is displayed.
- 6 Press the **MODE** button. The cursor moves to the tens digit of the year.
- 7 Press the **SEL** **▲** (up) or **SEL** **▼** (down) button until the desired tens digit of the year is displayed.
- 8 Press the **MODE** button. The cursor moves to the ones digit of the year.
- 9 Press the **SEL** **▲** (up) or **SEL** **▼** (down) button until the desired ones digit of the year is displayed.
- 10 Press the **MODE** button. The mileage and date setting is set, and then the display returns to the upper level hierarchy.

## **SUSPENSION**

**CBR1000S1**

"EQUIPMENT" is displayed but not selectable.

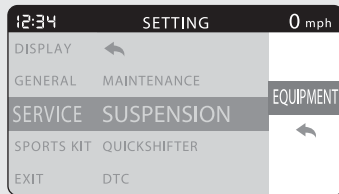

Select the **←** (return) on the menu screen. The display returns to the "SUSPENSION" menu on the "SERVICE" menu screen.

## Instruments (Continued)

### QUICK SHIFTER

CBR1000S1

"INITIALIZE" and "EQUIPMENT" are displayed but not selectable.

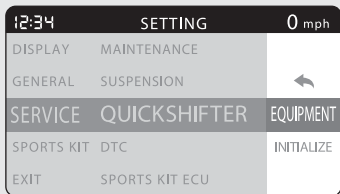

Select the  (return) on the menu screen, and then the display returns to the "QUICKSHIFTER" menu on the "SERVICE" menu screen.

### DTC

You can check for a current problem with the PGM-FI system.

CBR1000S1

You can check for a current problem with the ÖHLINS Smart EC system.

If your motorcycle has a problem, the DTC index is displayed. In this case, the pop-up information appears in the ordinary display.

 P.90

Reduce speed and have your motorcycle inspected by your dealer as soon as possible.

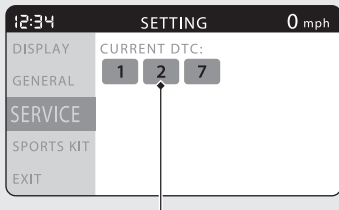

**DTC indexes**

To return to the upper level hierarchy, press the **MODE** button.

## **SPORTS KIT ECU**

"SPORTS KIT ECU USAGE" is displayed but not usable.

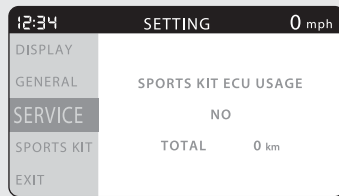

To return to the upper level hierarchy, press the **MODE** button.

## Instruments (Continued)

### Lap Timer

You can record lap time in the circuit mode.

➔ P.24

**Stopwatch/  
difference with the best lap**

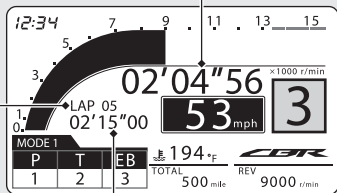

**Previous lap time**

**Previous lap number**

You can check and clear the recorded lap time data in the setting mode. ➔ P.55

➔ P.56

**Best icon  
(Displayed when the fastest lap  
time displayed.)**

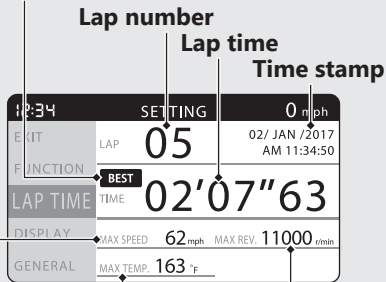

**Lap number**

**Lap time**

**Time stamp**

**Maximum  
vehicle  
speed**

**Maximum engine  
revolutions**

**Maximum coolant  
temperature**



The lap time data includes lap time, maximum vehicle speed, maximum engine revolutions, maximum coolant temperature, maximum acceleration, maximum deceleration, maximum left bank angle and maximum right bank angle.

Display range:

Previous lap number: 0 to 50

⌋ Exceeds 50, repeats the "50"

Previous lap time: 00'00"00 to 99'59"99

⌋ Exceeds 99'59"99, returns to the "00'00"00"

Stopwatch: 00'00"00 to 99'59"99

⌋ Exceeds 99'59"99, returns to the "00'00"00"

Difference with the best lap:

-99'5999 ~ 00'00"00 ~ +99'59"99"

Maximum vehicle speed:

0 to 186 mph (0 to 299 km/h)

Maximum engine revolutions:

0 to 20000 r/min (rpm)

Maximum coolant temperature:

-40 to 302°F (-40 to 150°C)

Maximum acceleration: 0 to 8.0 G

Maximum deceleration: 0 to 4.1 G

Maximum left bank angle:

0 to 90 deg

Maximum right bank angle:

0 to 90 deg

## Instruments (Continued)

### To Measure the Lap Time

- 1 Press and hold the **[LAP]** button or select the "CIRCUIT" menu on the "DISPLAY MODE" menu screen. **➡P.24** **➡P.58** **➡P.59**
- 2 To start measuring, press the **[LAP]** button.
  - ⊣ The stopwatch starts measuring.

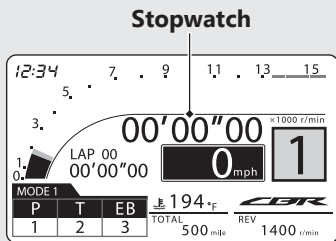

- 3 To record lap time, press the **[LAP]** button at each lap.
  - ⊣ The stopwatch changes to display the difference with the best lap. After 10 seconds, the display will return to the stopwatch.
  - ⊣ The previous lap time and previous lap number change to the information of the previous lap.
  - ⊣ If you press the **[LAP]** button again within two seconds, lap time is not recorded.
  - ⊣ When exceeds 50 lap, the previous lap number repeats the "LAP 50."

### Previous lap number

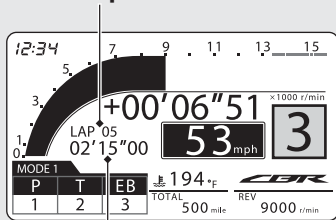

### Previous lap time

- 4 To end measurement, press and hold the **LAP** button.

### To Restart the Measurement

Press the **LAP** button again. The stopwatch restarts measuring.

- ↳ Measurement starts from the next lap.

### To Check or Clear the Lap Time

Select the "LAP TIME" menu in the setting

mode. **➡P.55** **➡P.57**

## Instruments (Continued)

### Pop-up information

In the following case, the INFO 3 display or the INFO 3 display and coolant temperature gauge change to a pop-up information display.

- Maintenance information:  
When the inspection time of your motorcycle is approaching.
- Helpful information:  
When your motorcycle has helpful information.
- Failure information:  
When your motorcycle has a problem with the PGM-FI system.

#### CBR1000S1



When your motorcycle has a problem with the ÖHLINS Smart EC system.

When your motorcycle has multiple pieces of information, each pop-up information display appears alternately.

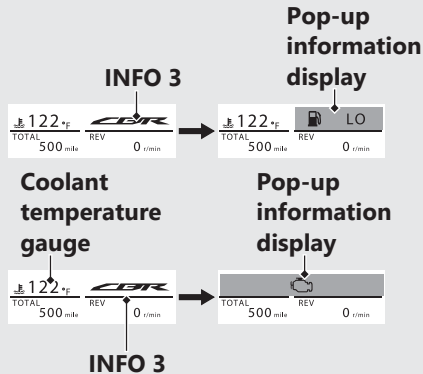



If your motorcycle has a problem with the PGM-FI and ÖHLINS Smart EC system, the failure information is displayed in priority to other information.



## Maintenance Information



Indication	Explanation	Remedy
 - 500 mile JUL/2017	When the periodic inspection time of your motorcycle is approaching	Have your motorcycle inspected by your dealer.
 - 500 mile JUL/2017	When the oil change time of your motorcycle is approaching	Change the engine oil.  P.145

## Helpful Information

Indication	Explanation	Remedy
 SIDE STAND	When the side stand is down	Raise the side stand.
 LO	When remaining fuel is reached 1.1 US gal (4.0 L).	Fill the fuel tank.  P.111
	<b>CBR1000S1</b> When the suspension initialization is waiting	Stop your motorcycle. Wait for a few seconds until the indication turns off. If indication dose not turn off, contact your dealer.

## Instruments *(Continued)*

### Failure Information

Indication	Explanation	Remedy
	When your motorcycle has a problem with the PGM-FI system	Reduce speed and have your motorcycle inspected by your dealer as soon as possible.
	<b>CBR1000S1</b> When your motorcycle has a problem with the ÖHLINS Smart EC system	Reduce speed and have your motorcycle inspected by your dealer as soon as possible.

# Indicators

If one of these indicators does not come on when it should, have your dealer check for problems.

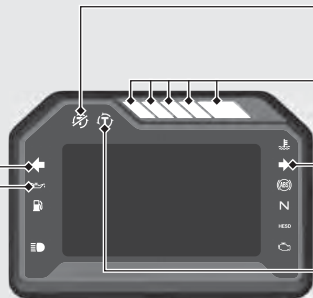

## **Low oil pressure indicator**

Comes on when the ignition switch is turned to the ON position. Goes off when the engine starts.

**If it comes on while engine is running:** 

## **Left turn signal indicator**

## **Torque Control OFF indicator**

Comes on when the Torque Control is turned off.

## **Shift indicators**

Comes on briefly when the ignition switch is turned to the ON position.

## **Right turn signal indicator**

## **Torque Control indicator**

- Comes on when the ignition switch is turned to the ON position. Goes off when your speed reaches approximately 3 mph (5 km/h) to indicate Torque Control is ready to work.
- Blinks when Torque Control is operating.

**If it comes on while riding:** 

## Indicators (Continued)



 **High beam indicator**

 **Low fuel indicator**

- Comes on briefly when the ignition switch is turned to the ON position.
- Comes on when there is only reserve fuel left in the fuel tank. Remaining fuel when low fuel indicator comes on: 1.1 US gal (4.0 L)

**If it comes on:**  **P.38**

 **High coolant temperature indicator**

Comes on briefly when the ignition switch is turned to the ON position.

**If it comes on while riding:**  **P.180**

 **ABS (Anti-lock Brake System) indicator**

**CBR1000RA/S1**

Comes on when the ignition switch is turned to the ON position. Goes off when your speed reaches approximately 6 mph (10 km/h).

**If it comes on while riding:**  **P.182**

 **Neutral indicator**

Comes on when the transmission is in Neutral.







### **HESD (Honda Electronic Steering Damper) indicator**

Comes on briefly when the ignition switch is turned to the ON position.

**If it comes on while engine is running:**

➔ P.182

### **PGM-FI (Programmed Fuel Injection) malfunction indicator lamp (MIL)**

Comes on briefly when the ignition switch is turned to the ON position with the engine stop switch in the  (Run) position. Comes on when the ignition switch is turned to the ON position with the engine stop switch in the  (Off) position

**If it comes on while engine is running:** ➔ P.181

## Indicators *(Continued)*

### Shift Indicators

The shift indicators light or blink by the engine revolutions. The first indicator lights when the engine revolutions reach a number 800 r/min (rpm) below a preset revolution number.

The second, third and fourth indicators will light each time the engine revolutions is 200 r/min (rpm) rise.

All indicators will blink when engine revolutions is reached the set value.

### Setting of the Shift Indicators

You can change the engine revolutions at which the shift indicators start blinking.

Initial setting: OFF

Available setting range:

4,000 to 16,600 r/min (rpm)

Example Set value: 11,600 r/min (rpm)

	0 to 10,800 r/min (rpm) All indicators go off
	10,800 r/min (rpm) First indicator comes on
	11,000 r/min (rpm) Second indicator comes on
	11,200 r/min (rpm) Third indicator comes on
	11,400 r/min (rpm) Fourth indicator comes on
	11,600 r/min (rpm) All indicators blink

BLANK PAGE

# Switches

## **LAP** button

Operate the lap timer



## Horn button



## Turn signal switch

Pressing the switch turns the turn signal off.





## Hazard switch

Switchable when the ignition switch is on. Can be turned to off regardless of the ignition switch position.

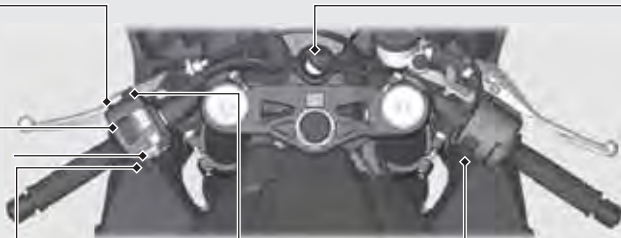
The signals continue flashing with the ignition switch is OFF or LOCK after the hazard switch is on.



## Headlight dimmer switch/Passing light control switch

-  : High beam
-  : Low beam
-  : Flashes the high beam headlight.

## Ignition Switch

Switches the electrical system on/off, locks the steering.

- ⌋ Key can be removed when in the OFF or LOCK position.

ON  
Turns electrical system on for starting/riding.

OFF  
Turns engine off.

LOCK  
Locks steering.



## Engine stop switch/ Start button

Should normally remain in the  (Run) position.

- ⌋ In an emergency, switch to the  (Off) position to stop the engine.

## Switches *(Continued)*

### Steering Lock

Lock the steering when parking to help prevent theft.

An U-shaped wheel lock or similar device is also recommended.

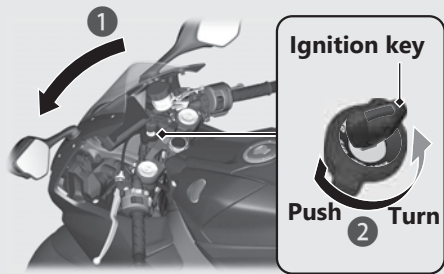

### Locking

- 1 Turn the handlebars all the way to the left.
- 2 Push the key down, and turn the ignition switch to the LOCK position.
  - ↳ Jiggle the handlebars if the lock is difficult to engage.
- 3 Remove the key.

### Unlocking

Insert the key, push it in, and turn the ignition switch to the OFF position.

# Riding mode

You can change the riding mode. The riding mode consists of the following parameters.

P: Engine output level

T: Torque control level

EB: Engine brake level

**CBR1000S1**

S: Suspension mode

When "-" is displayed, go to your dealer for service.

## Current riding mode

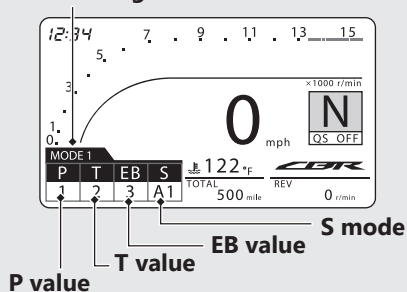

## Riding mode *(Continued)*

Riding mode has five modes.

Available riding mode: MODE 1, MODE 2, MODE 3, USER 1 and USER 2.

### MODE 1, MODE 2 and MODE 3

- ⊣ MODE 1 is suitable for track riding.
- ⊣ MODE 2 is suitable for winding roads.
- ⊣ MODE 3 is suitable for street riding.

#### CBR1000RR/RA

Each value can not be changed.

#### CBR1000S1

Each value and mode can not be changed.  
Setting of S mode can be changed

### USER 1 and USER 2

#### CBR1000RR/RA

Each value can be changed.

#### CBR1000S1

Each value and mode can be changed.  
Setting of S mode can be changed

## Initial setting

Riding modes	P value	T value	EB value	S mode	CBR1000S1
MODE 1	1	2	3	A1 <sup>*2</sup>	
MODE 2	2	5	3	A2 <sup>*2</sup>	
MODE 3	5	8	1	A3 <sup>*2</sup>	
USER 1	1 <sup>*1</sup>	5 <sup>*1</sup>	1 <sup>*1</sup>	M1 <sup>*3</sup>	
USER 2	2 <sup>*1</sup>	5 <sup>*1</sup>	2 <sup>*1</sup>	M2 <sup>*3</sup>	

Notes:

\*1 : Value can be changed.

\*2 : Setting of S mode can be changed

\*3 : S mode and setting of S mode can be changed



### **P value (Engine output level)**

P value has five setting levels.

Available setting range: 1 to 5

- ⌋ Level 1 has the most power.
- ⌋ Level 5 has the least power.

### **T value (Torque control level)**

T value has ten setting levels.

Available setting range: 0 to 9

- ⌋ Level 1 is the minimum Torque Control level
- ⌋ Level 9 is the maximum Torque Control level.
- ⌋ Level 0 deactivates the Torque Control.

### **EB value (Engine brake level)**

EB value has three setting levels.

Available setting range: 1 to 3

- ⌋ Level 1 has the strongest engine braking effect.
- ⌋ Level 3 has the weakest engine braking effect.

### **S mode (Suspension mode)**

**CBR1000S1**

S mode has six modes.

Available modes: A1, A2, A3, M1, M2 and M3

### **Adjusting the ÖHLINS Smart EC system**

**➔ P.170**

## Riding mode *(Continued)*

### Selecting the riding mode

- 1 Stop the motorcycle.
- 2 Select the riding mode display. P.27
- 3 Press the **SEL** (up) or **SEL** (down) button with the throttle fully closed.

**SEL** (up) button



**SEL** (down) button

**MODE** button

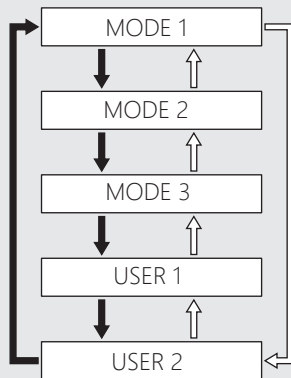

Press the **SEL** (up) button

Press the **SEL** (down) button

## Setting the riding mode

### CBR1000RR/RA

You can change the P, T and EB values on the USER 1 and USER 2 of the riding mode.

### CBR1000S1



You can change the P, T, EB value and S mode on the USER 1 and USER 2 of the riding mode.

- 1 Stop the motorcycle.
- 2 Select the USER 1 or USER 2 in the riding mode you want to set. **→ P.102**
- 3 Press and hold the **MODE** button until P value is selected.
- 4 Press the **SEL** **▲** (up) or **▼** (down) button until the desired value is displayed.

- 5 Press the **MODE** button until T value is selected.
- 6 Press the **SEL** **▲** (up) or **▼** (down) button until the desired value is displayed.
  - ↳ T value can be changed to level 0 by pressing and holding the **SEL** **▼** (down) button at the time of level 1.
- 7 Press the **MODE** button until EB value is selected.
- 8 Press the **SEL** **▲** (up) or **▼** (down) button until the desired value is displayed.
- 9 **CBR1000S1**  
Press the **MODE** button until S mode is selected.

## Riding mode *(Continued)*

### 10 CBR1000S1

Press the **SEL**  (up) or  (down) button until the desired mode is displayed.

11 Press and hold the **MODE** button until ordinary display is displayed.

You can stop setting the riding modes at any time by pressing and holding the **MODE** button.

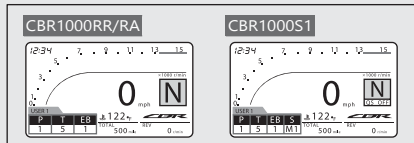

- Press the **MODE** button
- Press and hold the **MODE** button
- Press the **SEL** (up) button
- Press the **SEL** (down) button
- Press and hold the **SEL** (down) button

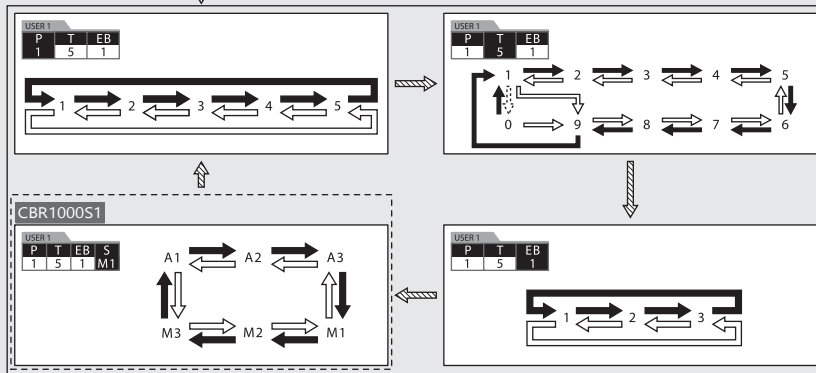

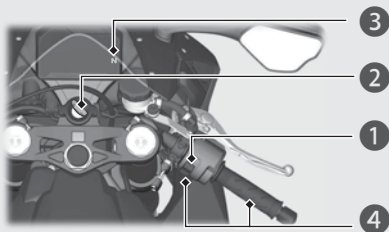

# Starting the Engine

Start your engine using the following procedure, regardless of whether the engine is cold or warm.



## NOTICE

- If the engine does not start within 5 seconds, turn the ignition switch to the OFF position and wait 10 seconds before trying to start the engine again to recover battery voltage.
- Extended fast idling and rewing the engine can damage the engine, and the exhaust system.
- Snapping the throttle or fast idling for more than about 5 minutes may cause exhaust pipe discoloration.
- The engine will not start if the throttle is fully open.

- 1 Make sure the engine stop switch is in the  (Run) position.
- 2 Turn the ignition switch to the ON position.
- 3 Shift the transmission to Neutral (  indicator comes on). Alternatively, pull in the clutch lever to start your motorcycle with the transmission in gear so long as the side stand is raised.
- 4 Press the start button with the throttle completely closed.

## If the engine does not start:

- a Open the throttle fully and press the start button for 5 seconds.
- b Repeat the normal starting procedure.
- c If the engine starts, open the throttle slightly if idling is unstable.
- d If the engine does not start, wait 10 seconds before trying steps **a** & **b** again.

**If Engine Will Not Start**  **P.179**

# Shifting Gears

Your motorcycle transmission has 6 forward gears in a one-down, five-up shift pattern.

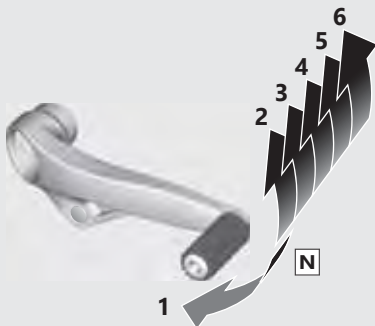

If you put the motorcycle in gear with the side stand down, the engine will shut off.

## Recommended Shift Points

### Shifting Up

From 1st to 2nd	12 mph (20 km/h)
From 2nd to 3rd	19 mph (30 km/h)
From 3rd to 4th	25 mph (40 km/h)
From 4th to 5th	31 mph (50 km/h)
From 5th to 6th	37 mph (60 km/h)

### Shifting Down

From 6th to 5th	28 mph (45 km/h)
From 5th to 4th	22 mph (35 km/h)
From 4th to 3rd	16 mph (25 km/h)

#### NOTICE

Improper shifting can damage the engine, transmission, and drive train. Also, coasting or towing the motorcycle for long distances with the engine off can damage the transmission.

## Shifting Gears *(Continued)*

### Quick Shifter

#### CBR1000S1

This system enables very quick up and down shifting without clutch and throttle operations.

- ⌋ This system does not function when upshifting with the throttle closed.
  - ⌋ This system functions when the engine speed is more than 1,500 r/min (rpm) on upshifting or more than the idle speed on downshifting.
  - ⌋ This system does not function when the clutch lever is being operated.
- If "-" is displayed on the gear position indicator, the Quick Shifter system does not operate.
  - If the Quick Shifter does not operate normally, the clutch can be used to complete the shift operation.

- The Quick Shifter can be individually turned ON (active) and OFF (deactivate), also the shift pedal load level for activating the Quick Shifter can be adjusted during up and down shifting.
- If the PGM-FI malfunction indicator lamp comes on or the gear position indicator flashes "-" in the current gear position, the Quick Shifter system may not operate. If either of the above occurs, contact your dealer as soon as possible.

### **To change the setting of Quick Shifter**

➡ P.45   ➡ P.46



# Refueling

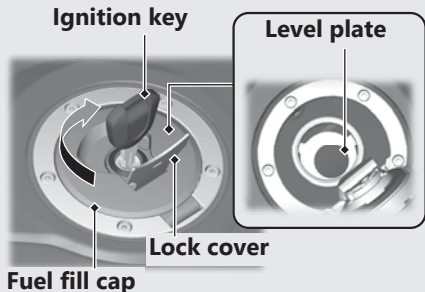

Do not fill with fuel above the level plate.

**Fuel type:** Unleaded gasoline only

**Recommended fuel octane number:**

Pump Octane Number (PON) 91 or higher.

**Tank capacity:** 4.28 US gal (16.2 L)

**Refueling and Fuel Guidelines** ➔ P.14

## Opening the Fuel Fill Cap

Open the lock cover, insert the ignition key, and turn it clockwise to open the cap.

## Closing the Fuel Fill Cap

- 1 After refueling, push the fuel fill cap closed until it locks.
- 2 Remove the key and close the lock cover.
  - ⊣ The key cannot be removed if the cap is not locked.

## 3WARNING

Gasoline is highly flammable and explosive. You can be burned or seriously injured when handling fuel.

- Stop the engine, and keep heat, sparks, and flame away.
- Handle fuel only outdoors.
- Wipe up spills immediately.

# Storage Equipment

## Helmet Holder

CBR1000RR/RA

The helmet holders are located on the underside of the rear seat.

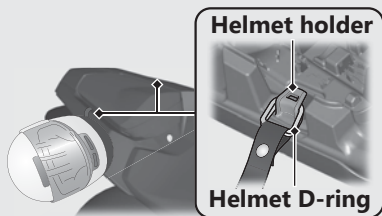

⌋ Use the helmet holder only when parked.

**Removing the Rear Seat** ➔ P.140

## 3 WARNING

Riding with a helmet attached to the holder can interfere with your ability to safely operate the motorcycle and could lead to a crash in which you can be seriously hurt or killed.

Use the helmet holder only while parked. Do not ride with a helmet secured by the holder.

## Tool Kit/Document Bag

CBR1000RR/RA

The tool kit and document bag are located under the rear seat.

CBR1000S1

The tool kit and document bag are located under the single seat cowl.

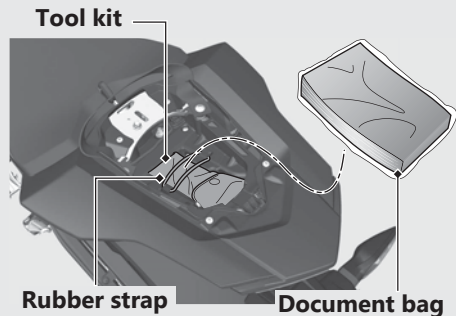

CBR1000RR/RA

Removing the rear seat → P.140

CBR1000S1

Removing single seat cowl → P.141

# Maintenance

Please read "Importance of Maintenance" and "Maintenance Fundamentals" carefully before attempting any maintenance. Refer to "Specifications" for service data.

An optional larger tool kit may be available.

Check with your Honda dealer's parts department.

<b>Importance of Maintenance</b> .....	P. 115	<b>Drive Chain</b> .....	P. 153
<b>Maintenance Schedule</b> .....	P. 117	<b>Clutch</b> .....	P. 157
<b>Maintenance Fundamentals</b> .....	P. 120	<b>Throttle</b> .....	P. 161
<b>Removing &amp; Installing Body</b>		<b>Other Adjustments</b> .....	P. 162
<b>Components</b> .....	P. 137	Adjusting the Headlight Aim .....	P. 162
Battery.....	P. 137	Adjusting the Brake Lever .....	P. 163
Front Seat.....	P. 139	Adjusting the Front Suspension .....	P. 164
Rear Seat.....	P. 140	Adjusting the Rear Suspension.....	P. 167
Single Seat Cowl.....	P. 141	Adjusting the ÖHLINS Smart EC System.....	P. 170
Under Cowl.....	P. 142		
<b>Engine Oil</b> .....	P. 143		
<b>Coolant</b> .....	P. 147		
<b>Brakes</b> .....	P. 149		
<b>Side Stand</b> .....	P. 152		

# Importance of Maintenance

## Importance of Maintenance

Keeping your motorcycle well-maintained is absolutely essential to your safety and to protect your investment, obtain maximum performance, avoid breakdowns, and reduce air pollution. Maintenance is the owner's responsibility. Be sure to inspect your motorcycle before each ride, and perform the periodic checks specified in the Maintenance Schedule. 2 P. 117

### **3** WARNING

Improperly maintaining your motorcycle or failing to correct a problem before you ride can cause a crash in which you can be seriously hurt or killed.

Always follow the inspection and maintenance recommendations and schedules in this owner's manual.

For information about the exhaust emission and noise emission requirements of the U.S. Environmental Protection Agency (EPA), the California Air Resources Board (CARB), and the Environment and Climate Change Canada (ECCC). 2 P. 211

**USA**

**Maintenance, replacement or repair of the emission control devices and systems may be performed by any motorcycle repair establishment or individual using parts that are "certified" to EPA standards.**

### Maintenance Safety

Always read the maintenance instructions before you begin each task, and make sure that you have the tools, parts, and skills required.

We cannot warn you of every conceivable hazard that can arise in performing maintenance. Only you can decide whether or not you should perform a given task.

Follow these guidelines when performing maintenance.

- Stop the engine and remove the key.
- Place your motorcycle on a firm, level surface using the side stand or a maintenance stand to provide support.
- Allow the engine, muffler, brakes, and other high-temperature parts to cool before servicing as you can get burned.
- Run the engine only when instructed, and do so in a well-ventilated area.











## Maintenance Schedule

The maintenance schedule specifies the maintenance requirements necessary to ensure safe, dependable performance, and proper emission control.

Maintenance work should be performed in accordance with Honda's standards and specifications by properly trained and equipped technicians. Your dealer meets all of these requirements. Keep an accurate record of maintenance to help ensure that your motorcycle is properly maintained. Make sure that whomever performs the maintenance completes this record.

All scheduled maintenance is considered a normal owner operating cost and will be charged to you by your dealer. Retain all receipts. If you sell the motorcycle, these receipts should be transferred with the motorcycle to the new owner.

# Maintenance Schedule

Items	Frequency*1								Regular Replace	Refer to page	
	× 1,000 mi	0.6	4	8	12	16	20	24			
	× 1,000 km	1.0	6.4	12.8	19.2	25.6	32.0	38.4			
Fuel Line					I		I		I		-
Throttle Operation					I		I		I		161
Air Cleaner *2						I			I		-
Spark Plug		Every 16,000 mi (25,600 km): I Every 32,000 mi (51,200 km): R									-
Valve Clearance							I				-
Engine Oil			R		R		R		R	1 Year	145
Engine Oil Filter			R				R				145
Engine Idle Speed					I		I		I		-
Radiator Coolant *4					I		I		I	3 Years	147
Cooling System					I		I		I		-
Secondary Air Supply System							I				-
Evaporative Emission Control System *3							I				-
Exhaust Gas Control Actuator Cable							I				-

## Maintenance Level

 : Intermediate. We recommend service by your dealer, unless you have the necessary tools and are mechanically skilled. Procedures are provided in an official Honda Service Manual (2 P. 217).

 : Technical. In the interest of safety, have your motorcycle serviced by your dealer.



















































## Maintenance Legend

I : Inspect (clean, adjust, lubricate, or replace, if necessary)

R : Replace

L : Lubricate



Items	Frequency*1								Regular Replace	Refer to page	
	× 1,000 mi	0.6	4	8	12	16	20	24			
	× 1,000 km	1.0	6.4	12.8	19.2	25.6	32.0	38.4			
Drive Chain	Every 600 mi (1,000 km):  									153	
Brake Fluid *4									2 Years	149	
Brake Pads Wear										150	
Brake System										120	
Brake light Switch										151	
Headlight Aim										162	
Clutch System										157	
Side Stand										152	
Suspension										164	
Front Fork Oil (CBR1000S1)		Every 18,000 mi (30,000 km) or 36 months: 									-
Nuts, Bolts, Fasteners										-	
Wheels/Tire										133	
Steering Head Bearings										-	

**Notes:**

\*1 : At higher odometer readings, repeat at the frequency interval established here.

\*2 : Service more frequently when riding in unusually wet or dusty areas.

\*3 : 50 STATE (meets California).

\*4 : Replacement requires mechanical skill.

## Pre-ride Inspection

To ensure safety, it is your responsibility to perform a pre-ride inspection and make sure that any problem you find is corrected. A pre-ride inspection is a must, not only for safety, but because having a breakdown, or even a flat tire, can be a major inconvenience.

Check the following items before you get on your motorcycle:

- Tire tread wear and air pressures are within limits. 2 P. 133
- Lights, horn, and turn signals operate normally.
- Check the condition of the drive chain. Adjust slack and lubricate as needed. 2 P. 131
- Combined weight is within load limits. 2 P. 223
- Cargo is secured properly.
- Suspension is adjusted to suit load. 2 P. 164, 2 P. 167

Check the following items after you get on your motorcycle:

- Throttle action moves smoothly without binding. 2 P. 161
- Brake lever and pedal operate normally.
- Refuel when needed. 2 P. 14, 2 P. 111
- Engine stop switch functions properly. 2 P. 98

Check the following items at regular intervals:

- Oil level is between the upper and lower level marks. 2 P. 143
- Brake fluid level is  
Front: between the UPPER and LOWER level marks. 2 P. 149  
Rear: between the UPPER and LOWER level marks. 2 P. 149
- Engine coolant level is between the UPPER and LOWER level marks. 2 P. 147
- Side stand functions properly. 2 P. 152

## Periodic Checks

You should also perform other periodic maintenance checks at least once a month regardless of how often you ride, or more often if you ride frequently.

Also, check the odometer reading against the Maintenance Schedule and perform all maintenance that is due. 2 P. 117

Tires and wheels	Check the air pressure (2 P. 133), examine tread for wear and damage (2 P. 133), and check the wheels for damage.
Fluid levels	Check the engine oil level (2 P. 143), engine coolant level (2 P. 147), and brake fluid level (2 P. 149).
Lights	Check that the headlight, position light, brake light, taillight, turn signals and license plate light are working properly.
Controls	Check the freeplay of the clutch lever (2 P. 157) and throttle grip (2 P. 161).
Drive chain	Check the slack (2 P. 153), adjust the slack (2 P. 154), and lubricate (2 P. 131) as needed.
Fuses	Check that you have a full supply of spare fuses.
Nuts & bolts	Check the major nuts and bolts, and tighten as needed.

### Replacing Parts

Always use Honda Genuine Parts or their equivalents to ensure reliability and safety. When ordering colored components, specify the model name, color, and code mentioned on the color label.

The color label is attached on the inside of the left duct.



Color label

### **3**WARNING

Installing non-Honda parts may make your motorcycle unsafe and cause a crash in which you can be seriously hurt or killed.

Always use Honda Genuine Parts or equivalents that have been designed and approved for your motorcycle.

## Battery

### CBR1000S1

Your motorcycle has a lithium-ion (li-ion) battery. 2 P. 125

### CBR1000RR/RA

Your motorcycle has a maintenance-free type battery. You do not have to check the battery electrolyte level or add distilled water. Clean the battery terminals if they become dirty or corroded.

Do not remove the battery cap seals. There is no need to remove the cap when charging.

### NOTICE

An improperly disposed of battery can be harmful to the environment and human health. Always confirm local regulations for proper battery disposal instruction.

### What to do in an emergency

If any of the following occur, immediately see your doctor.

- Electrolyte splashes into your eyes:
  - ⊔ Wash your eyes repeatedly with cool water for at least 15 minutes. Using water under pressure can damage your eyes.
- Electrolyte splashes onto your skin:
  - ⊔ Remove affected clothing and wash your skin thoroughly using water.

- Electrolyte splashes into your mouth:
  - Rinse mouth thoroughly with water, and do not swallow.

### 3 **WARNING**

The battery gives off explosive hydrogen gas during normal operation.

A spark or flame can cause the battery to explode with enough force to kill or seriously hurt you.

Wear protective clothing and a face shield, or have a skilled mechanic do the battery servicing.

**WARNING:** Battery posts, terminals, and related accessories contain lead and lead compounds.

**Wash your hands after handling.**

### **Cleaning the Battery Terminals**

1. Remove the battery. 2 P. 137
2. If the terminals are starting to corrode and are coated with a white substance, wash with warm water and wipe clean.
3. If the terminals are heavily corroded, clean and polish the terminals with a wire brush or sandpaper. Wear safety glasses.

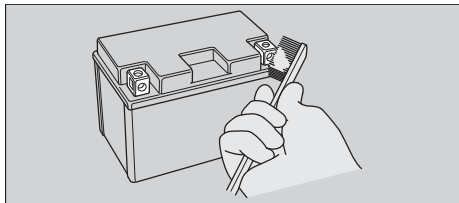

4. After cleaning, reinstall the battery.

The battery has a limited life span. Consult your dealer about when you should replace the battery. Always replace the battery with another maintenance-free battery of the same type.

## Charging

If you use electrical accessories that drain the battery or you do not ride frequently, we recommend that you charge the battery every 30 days using a charger designed specifically for your Honda, which can be purchased from your dealer. Read the information that came with your battery charger and follow the instructions on the battery. Avoid using an automobile-type battery charger, as these can overheat a motorcycle battery and cause permanent damage.

Make sure the ignition switch is in the OFF position before charging the battery.

### NOTICE

Improper charging can damage the battery. If you can't charge the battery or it appears unable to hold a charge, contact your dealer.

### NOTICE

Jump starting using an automobile battery can damage your motorcycle's electrical system and is not recommended. Bump starting is also not recommended.

### NOTICE

Installing non-Honda electrical accessories can overload the electrical system, discharging the battery and possibly damaging the system.

## Lithium-Ion (Li-Ion) Battery

### CBR1000S1

Your motorcycle has a lithium-ion (li-ion) battery. Clean the battery terminals if they become dirty or corroded.

### NOTICE

An improperly disposed of battery can be harmful to the environment and human health. Always confirm local regulations for proper battery disposal instruction.

### What to do in an emergency

If any of the following occurs, immediately see your doctor.

- Electrolyte splashes into your eyes:
  - ⌋ Wash your eyes repeatedly with cool water for at 15 minutes. Using water under pressure can damage your eyes.
- Electrolyte splashes onto your skin:
  - ⌋ Remove affected clothing and wash your skin thoroughly using water.
- Electrolyte splashes into your mouth
  - ⌋ Rinse mouth thoroughly with water, and do not swallow.

### 3 WARNING

The battery contains flammable organic solvent as electrolyte.

You can be burned or seriously injured if the battery is handled improperly.

- Keep the battery away from heat, sparks, and flame.
- Keep the battery out of the reach of children.
- Do not disassemble or modify the battery or battery terminals.
- Do not short-circuit the battery with metal tools or other metal objects.
- Do not subject the battery to impacts.



### **| Cleaning the Battery Terminals**

1. Remove the battery. 2 P. 137
2. If the terminals are starting to corrode and are coated with a white substance, wash with warm water and wipe clean.
3. If the terminals are heavily corroded, clean and polish the terminals with a wire brush or sandpaper. Wear safety glasses.

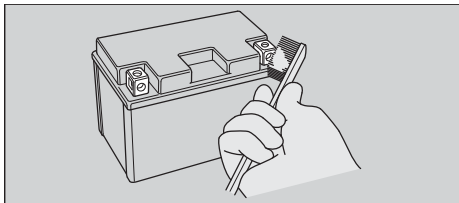

4. After cleaning, reinstall the battery.

The battery has a limited life span. Consult your dealer about when you should replace the battery. Always replace the battery with another lithium-ion (li-ion) battery of the same type.

### Charging

If you use electrical accessories that drain the battery or you do not ride frequently, we recommend that you charge the battery every 30 days using a charger recommended by your lithium-ion (li-ion) battery manufacturer.

Contact your dealer before charging the battery.

Make sure the ignition switch is in the OFF position before charging the battery.

#### NOTICE

Only use a charger recommended by your lithium-ion (li-ion) battery manufacturer. Using a battery charger that is not recommended can cause permanent damage to your battery.

#### NOTICE

Improper charging can damage the battery. If you can't charge the battery or it appears unable to hold a charge, contact your dealer.

#### NOTICE

Do not jump-start, as this can damage your motorcycle's electrical system and battery. Bump starting is not recommended.

#### NOTICE

Installing non-Honda electrical accessories can overload the electrical system, discharging the battery and possibly damaging the system.

## Fuses

Fuses protect the electrical circuits on your motorcycle. If something electrical on your motorcycle stops working, check for and replace any blown fuses. 2 P. 197

### Inspecting and Replacing Fuses

Turn the ignition switch to the OFF position to remove and inspect fuses. If a fuse is blown, replace with a fuse of the same rating. For fuse ratings, see "Specifications." 2 P. 225

Blown fuse

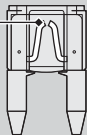

#### NOTICE

Replacing a fuse with one that has a higher rating greatly increases the chance of damage to the electrical system.

If a fuse fails repeatedly, you likely have an electrical fault. Have your motorcycle inspected by your dealer.

## Engine Oil

Engine oil consumption varies and oil quality deteriorates according to riding conditions and time elapsed.

Check the engine oil level regularly, and add the recommended engine oil if necessary. Dirty oil or old oil should be changed as soon as possible.

### Selecting the Engine Oil

For recommended engine oil, see "Specifications." 2 P. 224

If you use non-Honda engine oil, check the label to make sure that the oil satisfies all of the following standards:

- JASO T 903 standard\*1: MA
- SAE standard\*2: 10W-30
- API classification\*3: SG or higher

## Maintenance Fundamentals

- \*1. The JASO T 903 standard is an index for engine oils for 4-stroke motorcycle engines. There are two classes: MA and MB. For example, the following label shows the MA classification.

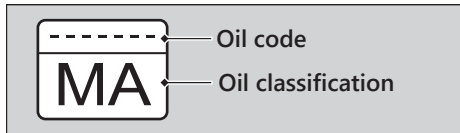

- \*2. The SAE standard grades oils by their viscosity.
- \*3. The API classification specifies the quality and performance rating of engine oils. Use SG or higher oils, excluding oils marked as "Energy Conserving" or "Resource Conserving" on the circular API service symbol.

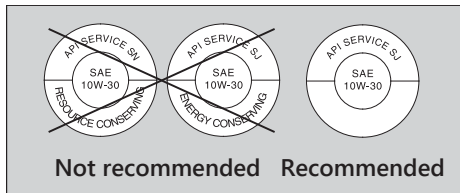

## Brake Fluid

Do not add or replace brake fluid, except in an emergency. Use only fresh brake fluid from a sealed container. If you do add fluid, have the brake system serviced by your dealer as soon as possible.

### NOTICE

Brake fluid can damage plastic and painted surfaces. Wipe up spills immediately and wash thoroughly.

### Recommended brake fluid:

Honda DOT 4 Brake Fluid or equivalent

## 3WARNING

Clean filler cap before removing. Use only DOT 4 fluid from a sealed container.

## Drive Chain

The drive chain must be inspected and lubricated regularly. Inspect the chain more frequently if you often ride on bad roads, ride at high speed, or ride with repeated fast acceleration. 2 P. 153

If the chain does not move smoothly, makes strange noises, has damaged rollers, has loose pins, has missing O-rings, or kinks, have the chain inspected by your dealer.

Also inspect the drive sprocket and driven sprocket. If either has worn or damaged teeth, have the sprocket replaced by your dealer.

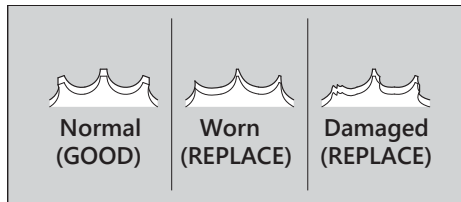

### NOTICE

Use of a new chain with worn sprockets will cause rapid chain wear.

### Cleaning and Lubricating

After inspecting the slack, clean the chain and sprockets while rotating the rear wheel. Use a dry cloth with chain cleaner designed specifically for O-ring chains, or neutral detergent. Use a soft brush if the chain is dirty.

After cleaning, wipe dry and lubricate with the recommended lubricant.

### Recommended lubricant:

Pro Honda HP Chain Lube or equivalent

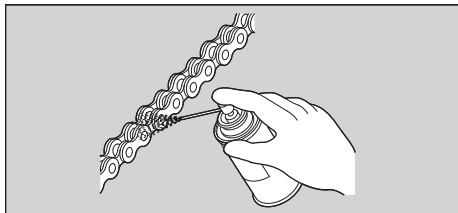

## Maintenance Fundamentals

Do not use a steam cleaner, a high pressure cleaner, a wire brush, volatile solvent such as gasoline and benzene, abrasive cleaner, chain cleaner or lubricant NOT designed specifically for O-ring chains as these can damage the rubber O-ring seals.

Avoid getting lubricant on the brakes or tires.

Avoid applying excess chain lubricant to prevent spray onto your clothes and the motorcycle.

### Recommended Coolant

Pro Honda HP Coolant is a pre-mixed solution of antifreeze and distilled water.

#### Concentration:

50% antifreeze and 50% distilled water

A concentration of antifreeze below 40% will not provide proper corrosion and cold temperature protection.

A concentration of up to 60% will provide better protection in colder climates.

#### NOTICE

Using coolant not specified for aluminum engines or tap/mineral water can cause corrosion.

## Tires (Inspecting/Replacing)

### Checking the Air Pressure

Visually inspect your tires and use an air pressure gauge to measure the air pressure at least once a month or any time you think the tires look low. Always check air pressure when your tires are cold.

Even if the direction of the valve stem is changed, do not return it to the original position. Have your motorcycle inspected by your dealer.

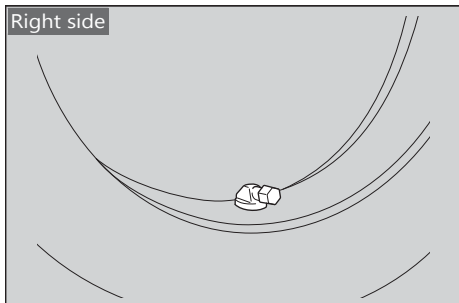

### Inspecting for Damage

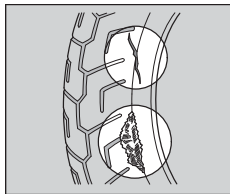

Inspect the tires for cuts, slits, or cracks that exposes fabric or cords, or nails or other foreign objects embedded in the side of the tire or the tread.

Also inspect for any unusual bumps or bulges in the side walls of the tires.

### Inspecting for Abnormal Wear

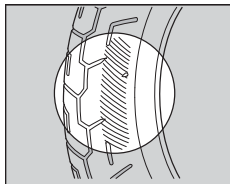

Inspect the tires for signs of abnormal wear on the contact surface.

### Inspecting Tread Depth

Inspect the tread wear indicators. If they become visible, replace the tires immediately.

## Maintenance Fundamentals

For safe riding, you should replace the tires when the minimum tread depth is reached.

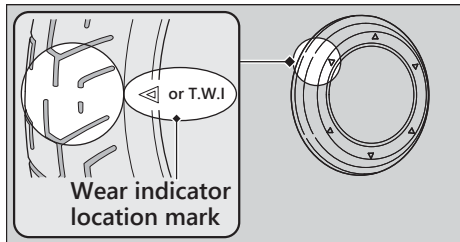

## 3WARNING

Riding on tires that are excessively worn or improperly inflated can cause a crash in which you can be seriously hurt or killed.

Follow all instructions in this owner's manual regarding tire inflation and maintenance.



Have your tires replaced by your dealer. For recommended tires, air pressure and minimum tread depth, see "Specifications." 2 P. 224

Follow these guidelines whenever you replace tires.

- Use the recommended tires or equivalents of the same size, construction, speed rating, and load range.
- Have the wheel balanced with Honda Genuine balance weights or equivalent after the tire is installed.
- Do not install a tube inside a tubeless tire on this motorcycle. Excessive heat build-up can cause the tube to burst.
- Use only tubeless tires on this motorcycle. The rims are designed for tubeless tires, and during hard acceleration or braking, a tube-type tire could slip on the rim and cause the tire to rapidly deflate.

## **3**WARNING

Installing improper tires on your motorcycle can adversely affect handling and stability, and can cause a crash in which you can be seriously hurt or killed.

Always use the size and type of tires recommended in this owner's manual.

### Tire Service Life

The service life of your tires is dependent on many factors, including, but not limited to, riding habits, road conditions, vehicle loading, tire air pressure, maintenance history, speed, and environmental conditions (even when the tires are not in use).

In addition to your regular inspections and maintenance, it is recommended that you have annual inspections performed once the tires reach 5 years old. It is also recommended that all tires be removed from service after 10 years from the date of manufacture, regardless of their condition or state of wear.

The last four digits of the TIN (tire identification number) indicate the date of manufacture.

### Tire Identification Number (TIN)

The tire identification number (TIN) is a group of numbers and letters located on the sidewall of the tire.

a      b      c  
**DOT XXXX XXXX 22 09**

DOT:      This indicates that the tire meets all requirements of the U.S. Department of Transportation.

a XXXX:    Factory code

b XXXX:    Tire type code

c 22 09:    Date of manufacture (week & year).  
Example: week 22 in year 09.

#### Tire Labeling Example

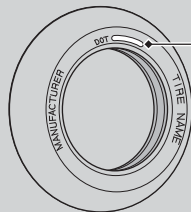

**Tire identification number (TIN)**

# Removing & Installing Body Components

## Battery

CBR1000RR/RA

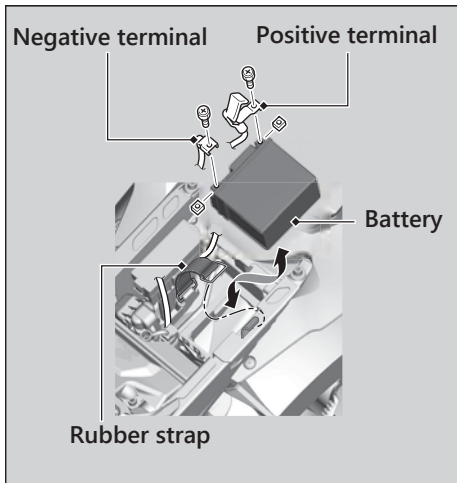

CBR1000S1

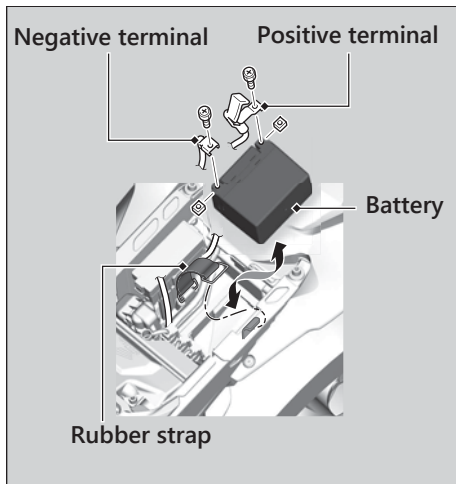

### ■ Removal

Make sure the ignition switch is in the OFF position.

1. Remove the front seat. 2 P. 139
2. Unhook the rubber strap from left side.
3. Disconnect the negative - terminal from the battery.
4. Disconnect the positive + terminal from the battery.
5. Remove the battery taking care not to drop the terminal nuts.

### ■ Installation

Install the parts in the reverse order of removal.

Always connect the positive + terminal first.

Make sure that bolts and nuts are tight.

Make sure the clock information is correct

after the battery is reconnected. 2 P. 70

For proper handling of the battery, see

“Maintenance Fundamentals.” 2 P. 123

“Battery Goes Dead.” 2 P. 193

## Front Seat

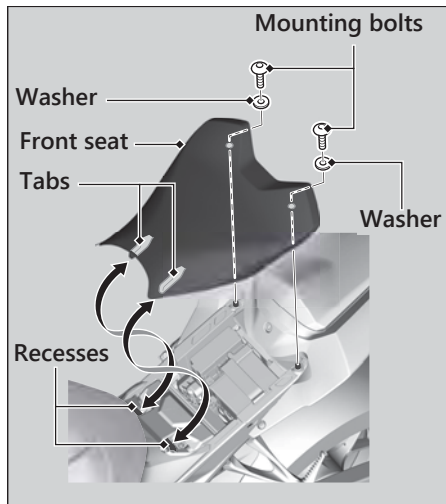

### Removal

1. Remove the mounting bolts and washers, and then pull the front seat back and up.

### Installation

1. Install the front seat while inserting the tabs into the recesses.
2. Install the washers and mounting bolts.
3. Tighten the mounting bolts securely. Make sure that the seat is locked securely in position to pull it up lightly.

## Rear Seat

CBR1000RR/RA

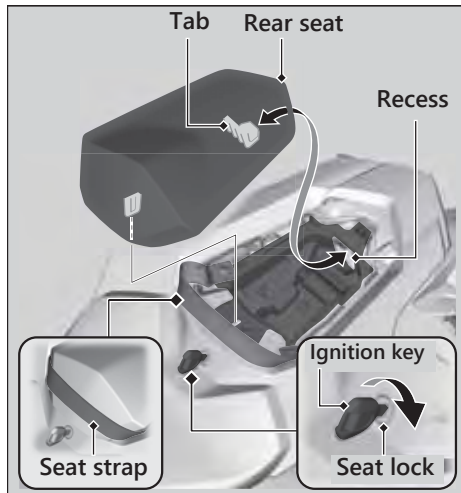

### Removal

1. Move the seat strap forward.
2. Insert the ignition key into the seat lock.
3. Turn the ignition key clockwise, then pull the rear seat forward and up.

### Installation

1. Insert the tab into the recess.
2. Push down on the front of the rear seat. Make sure that the seat is locked securely in position to pull it up lightly.
3. Move the seat strap to its original position.

The seat locks automatically when closed. Take care not to lock your key in the compartment under the rear seat.

## Single Seat Cowl

CBR1000S1

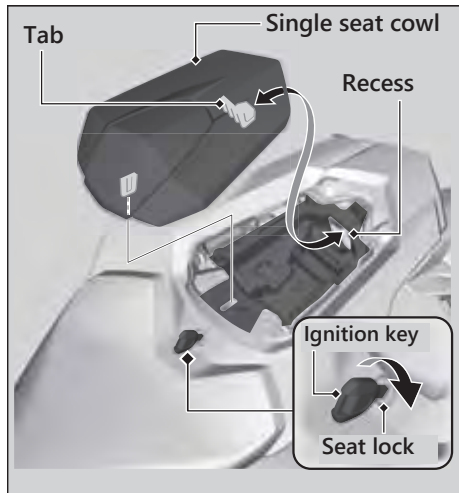

### Removal

1. Insert the ignition key into the seat lock.
2. Turn the ignition key clockwise, then pull the single seat cowl forward and up.

### Installation

1. Insert the tab into the recess.
2. Push down on the front of the single seat cowl.

Make sure that the single seat cowl is locked securely in position to pull it up lightly.

The single seat cowl locks automatically when closed.

Take care not to lock your key in the compartment under the single seat cowl.

## Under Cowl

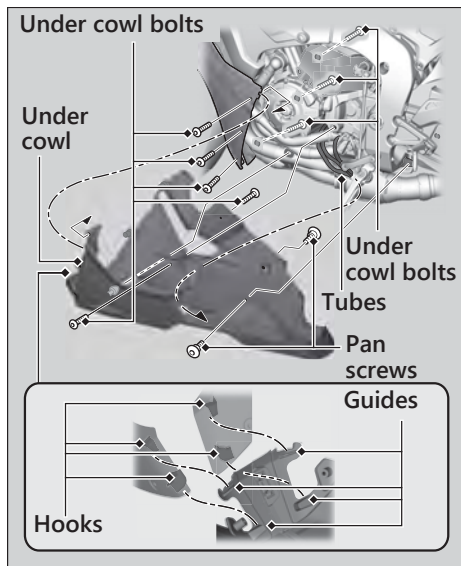

### Removal

1. Remove the pan screws and under cowl bolts.
2. Remove the under cowl carefully by releasing the guides from the hooks of the middle cowl side as shown in the illustration.

### Installation

1. Install the under cowl using reverse of the removal procedure.
2. Route the tubes through the opening of the lower cowl.
3. Install and tighten the under cowl bolts securely.
4. Install and tighten the pan screws securely.



## Checking the Engine Oil

1. If the engine is cold, idle the engine for 3 to 5 minutes.
2. Turn the ignition switch to the OFF position and wait for 2 to 3 minutes.
3. Place your motorcycle in an upright position on a firm, level surface.
4. Remove the dipstick and wipe it clean.
5. Insert the dipstick until it seats, but don't screw it in.
6. Check that the oil level is between the upper level and lower level marks in the dipstick.
7. Securely install the dipstick.

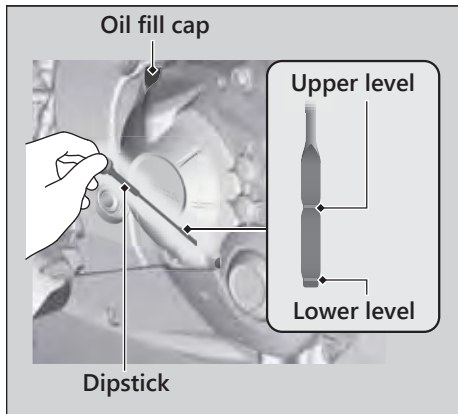

## Adding Engine Oil

---

If the engine oil is below or near the lower level mark, add the recommended engine oil.  
≥ P. 129, ≥ P. 224

1. Remove the oil fill cap. Add the recommended oil until it reaches the upper level mark.
  - U Place your motorcycle in an upright position on a firm, level surface when checking the oil level.
  - U Do not overfill above the upper level mark.
  - U Make sure no foreign objects enter the oil filler opening.
  - U Wipe up any spills immediately.

2. Securely reinstall the oil fill cap.

### NOTICE

Overfilling with oil or operating with insufficient oil can cause damage to your engine. Do not mix different brands and grades of oil. They may affect lubrication and clutch operation.

For the recommended oil and oil selection guidelines, see “Maintenance Fundamentals.”  
≥ P. 129

## Changing Engine Oil & Filter

Changing the oil and filter requires special tools. We recommend that you have your motorcycle serviced by your dealer.

Use a new Honda Genuine oil filter or equivalent specified for your model.

### NOTICE

Using the wrong oil filter can result in serious damage to the engine.

1. Remove the under cowl. 2 P. 142
2. If the engine is cold, idle the engine for 3 to 5 minutes.
3. Turn the ignition switch to the OFF position and wait for 2 to 3 minutes.
4. Place your motorcycle on a firm, level surface.

5. Place a drain pan under the drain bolt.
6. Remove the oil fill cap, drain bolt, and sealing washer to drain the oil.

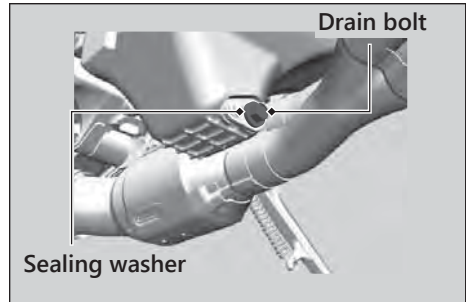

- Remove the oil filter with a filter wrench and let the remaining oil drain out. Make sure the prior seal is not stuck to the engine.
  - U Discard the oil and oil filter at an approved recycling center.

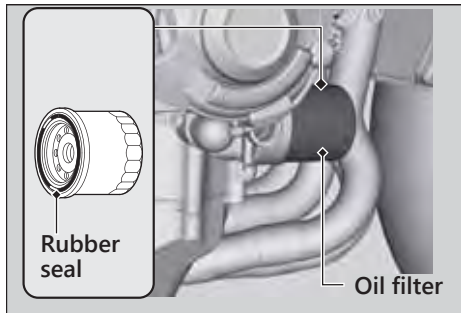

- Apply a thin coat of engine oil to the rubber seal of a new oil filter.

- Install the new oil filter and tighten.

**Torque:** 19 lbf·ft (26 N·m, 2.7 kgf·m)

- Install a new sealing washer onto the drain bolt. Tighten the drain bolt.

**Torque:** 22 lbf·ft (30 N·m, 3.1 kgf·m)

- Fill the crankcase with the recommended oil (2 P. 129, 2 P. 224) and install the oil fill cap.

### Required oil

#### When changing oil & engine oil filter:

2.9 US qt (2.7 L)

#### When changing oil only:

2.6 US qt (2.5 L)

- Check the oil level. 2 P. 143
- Check that there are no oil leaks.
- Install the under cowl.

## Checking the Coolant

---

Check the coolant level in the reserve tank while the engine is cold.

1. Place your motorcycle on a firm, level surface.
2. Hold your motorcycle in an upright position.
3. Check that the coolant level is between the UPPER level and LOWER level marks in the reserve tank.

If the coolant level is dropping noticeably or the reserve tank is empty, you likely have a serious leak. Have your motorcycle inspected by your dealer.

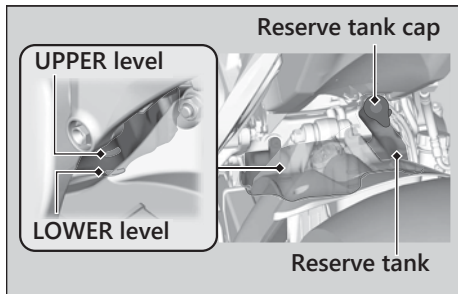

## Adding Coolant

---

If the coolant level is below the LOWER level mark, add the recommended coolant (2 P. 132) until the level reaches the UPPER level mark.

Add fluid only from the reserve tank cap and do not remove the radiator cap.

## Coolant $\cup$ Changing Coolant

1. Remove the reserve tank cap and add fluid while monitoring the coolant level.
  - $\cup$  Do not overfill above the UPPER level mark.
  - $\cup$  Make sure no foreign objects enter the reserve tank opening.
2. Securely reinstall the reserve tank cap.

### **3**WARNING

Removing the radiator cap while the engine is hot can cause the coolant to spray out, potentially scalding you.

Always let the engine and radiator cool down before removing the radiator cap.

## Changing Coolant

---

Have your dealer change the coolant unless you have the proper tools and are mechanically qualified.

## Checking Brake Fluid

1. Place your motorcycle in an upright position on a firm, level surface.
2. Check that the brake fluid reservoir is horizontal and that the fluid level is between the LOWER level and UPPER level marks.

If the brake fluid level in either reservoir is below the LOWER level mark or the brake lever and pedal freeplay becomes excessive, inspect the brake pads for wear.

If the brake pads are not worn, you most likely have a leak. Have your motorcycle inspected by your dealer.

Front

Front brake fluid reservoir

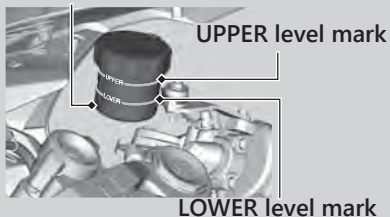

Rear

Rear brake fluid reservoir

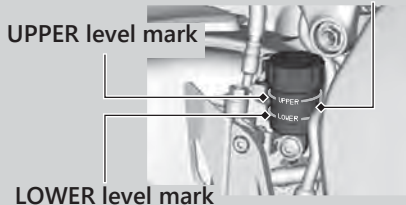

## Inspecting the Brake Pads

Check the condition of the brake pad wear indicators.

**Front** The pads need to be replaced if a brake pad is worn to the bottom of the indicator.

**Rear** The pads need to be replaced if a brake pad is worn to the indicator.

1. **Front** Inspect the brake pads from in front of the brake caliper.
  - U Always inspect both left and right brake calipers.
2. **Rear** Inspect the brake pads from the rear right of the motorcycle.

If necessary have the pads replaced by your dealer.

Always replace both left and right brake pads at the same time.

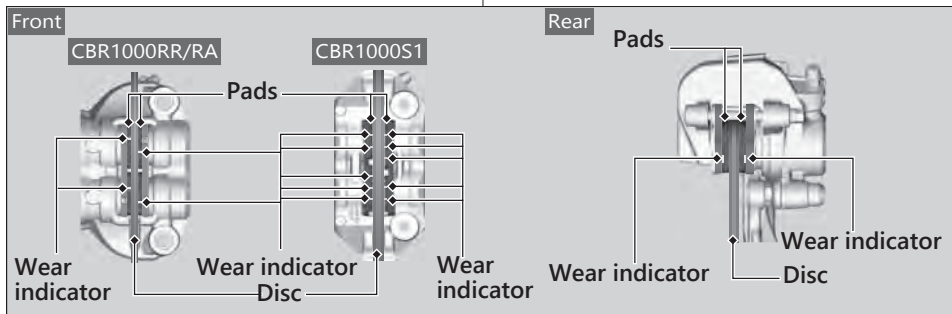



## Adjusting the Brake Light Switch

Check the operation of the brake light switch. Hold the brake light switch and turn the adjusting nut in the direction A if the switch operates too late, or turn the nut in the direction B if the switch operates too soon.

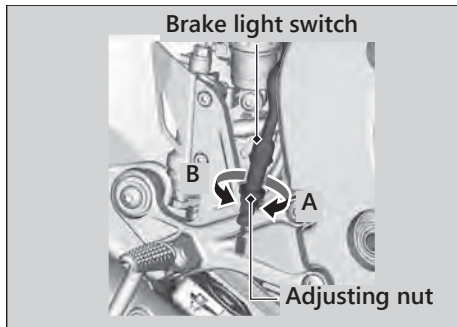

## Checking the Side Stand

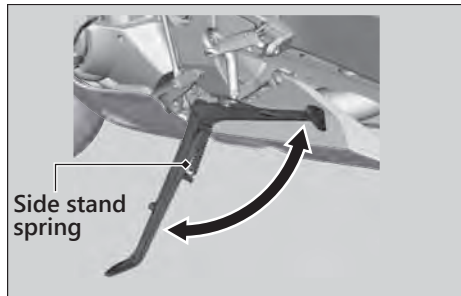

1. Check that the side stand operates smoothly. If the side stand is stiff or squeaky, clean the pivot area and lubricate the pivot bolt with clean grease.
2. Check the spring for damage or loss of tension.
3. Sit on the motorcycle, shift the transmission to Neutral, and raise the side stand.

4. Start the engine, pull the clutch lever in, and shift the transmission into gear.
5. Lower the side stand all the way. The engine should stop as you lower the side stand. If the engine doesn't stop, have your motorcycle inspected by your dealer.

## Inspecting the Drive Chain Slack

Check the drive chain slack at several points along the chain. If the slack is not constant at all points, some links may be kinked and binding.

Have the chain inspected by your dealer.

1. Shift the transmission to Neutral. Stop the engine.
2. Place your motorcycle on its side stand on a firm, level surface.
3. Check the slack in the lower half of the drive chain midway between the sprockets.

### Drive chain slack:

1.0 - 1.4 in (25 - 35 mm)

- ⌋ Do not ride your motorcycle if the slack exceeds 2.0 in (50 mm).

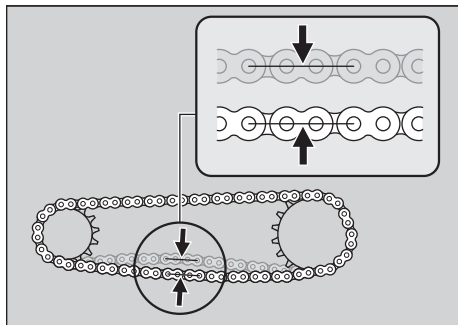

4. Roll the motorcycle forward and check that the chain moves smoothly.
5. Inspect the sprockets. 2 P. 131
6. Clean and lubricate the drive chain. 2 P. 131

## Adjusting the Drive Chain Slack

Adjusting the chain requires special tools. Have the drive chain slack adjusted by your dealer.

When adjusting the drive chain slack, be careful not to damage the wheel speed sensor and pulser ring.

1. Shift the transmission to Neutral. Stop the engine.
2. Place your motorcycle on its side stand on a firm, level surface.
3. Loosen the rear axle nut.
4. Loosen the lock nuts on both adjusting bolts.

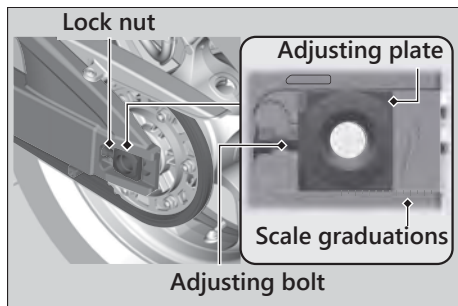
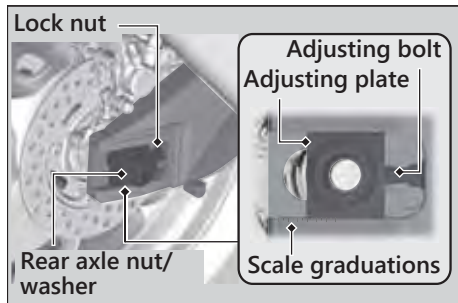

5. Turn both adjusting bolts an equal number of turns until the correct drive chain slack is obtained. Turn the adjusting bolts counterclockwise to tighten the chain. Turn the adjusting bolts clockwise and push the rear wheel toward the front to provide more slack.  
Adjust the slack at a point midway between the front sprocket and the rear wheel sprocket  
Check the drive chain slack. 2 P. 153
6. Check rear axle alignment by making sure the end of the chain adjusting plate aligns with the scale graduations on both sides of the swingarm.  
Both marks should correspond. If the axle is misaligned, turn the right or left adjusting bolt until the marks are aligned and recheck chain slack

7. Tighten the rear axle nut.

**Torque:** 100 lbf-ft (135 N·m, 13.8 kgf·m)

8. Hold the adjusting bolts and tighten the lock nuts.
9. Recheck drive chain slack.

If a torque wrench was not used for installation, see your dealer as soon as possible to verify proper assembly. Improper assembly may lead to loss of braking capacity.

## Checking the Drive Chain Wear

Check the chain wear label when adjusting the drive chain. If the front edge of the adjusting plate enters the red zone on the label after the chain has been adjusted to the proper slack, the chain is excessively worn and must be replaced.

**Chain:** RK525ROZ7

If necessary have the drive chain replaced by your dealer.

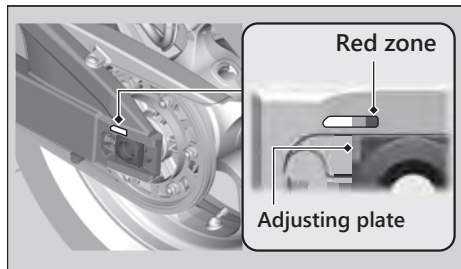

## Checking the Clutch

### Checking the Clutch Lever Freeplay

Check the clutch lever freeplay.

#### Freeplay at the clutch lever:

0.4 - 0.8 in (10 - 20 mm)

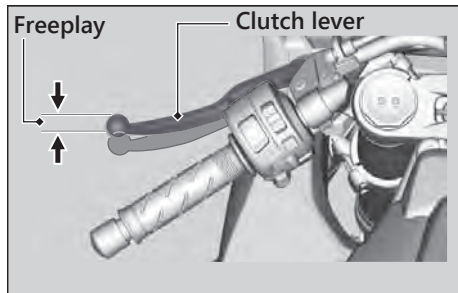

Check the clutch cable for kinks or signs of wear. If necessary have it replaced by your dealer.

Lubricate the clutch cable with a commercially available cable lubricant to prevent premature wear and corrosion.

#### NOTICE

Improper freeplay adjustment can cause premature clutch wear.

## Adjusting the Clutch Lever Freeplay

### Upper Adjustment

Attempt adjustment with the upper clutch cable adjuster first.

Turn the clutch cable adjuster until the freeplay is 0.4 - 0.8 in (10 - 20 mm).

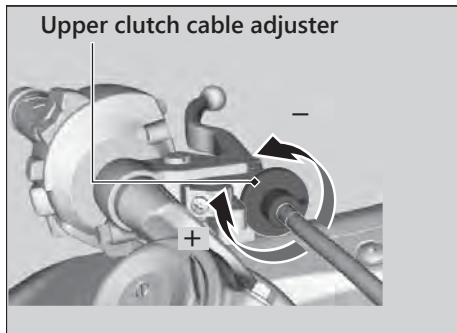



## Lower Adjustment

If the upper clutch cable adjuster is threaded out near its limit, or the correct freeplay cannot be obtained, attempt adjustment with the lower clutch cable adjusting nut.

1. Turn the upper clutch cable adjuster all the way in (to provide maximum freeplay).
2. Remove the under cowl.  $\geq$  P. 142
3. Remove the pan screw and under cowl bolt.
4. Remove the rear under cover.

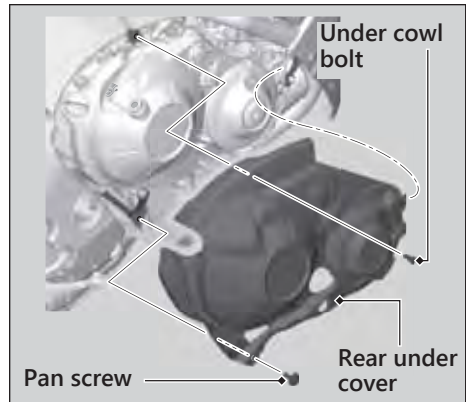

## Clutch □ Adjusting the Clutch Lever Freeplay

5. Loosen the lower lock nut.
6. Turn the adjusting nut until the clutch lever freeplay is 0.4 - 0.8 in (10 - 20 mm).
7. Tighten the lower lock nut and check the clutch lever freeplay.
8. Install the rear under cover using reverse of the removal procedure.
9. Install and tighten the under cowl bolt and pan screw securely.
10. Install the under cowl. 2 P. 142
11. Start the engine, pull the clutch lever in, and shift into gear. Make sure the engine does not stall and the motorcycle does not creep. Gradually release the clutch lever and open the throttle. Your motorcycle should move smoothly and accelerate gradually.

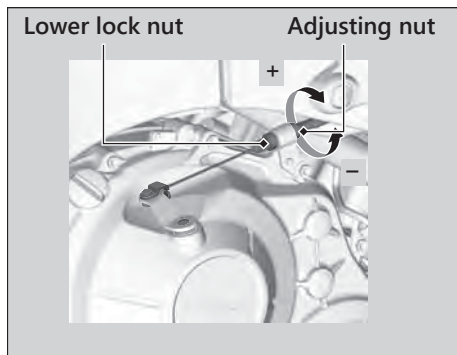

If proper adjustment cannot be obtained or the clutch does not work correctly, see your dealer.

## Checking the Throttle

---

With the engine off, check that the throttle rotates smoothly from fully closed to fully open. If the throttle does not move smoothly, close automatically, have the motorcycle inspected by your dealer.

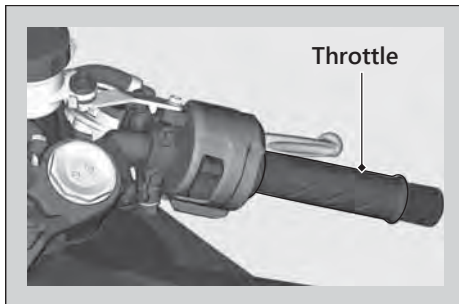

### Adjusting the Headlight Aim

You can adjust vertical aim of the headlight for proper alignment. Turn the screw in or out as necessary using a Phillips screwdriver. Obey local laws and regulations.

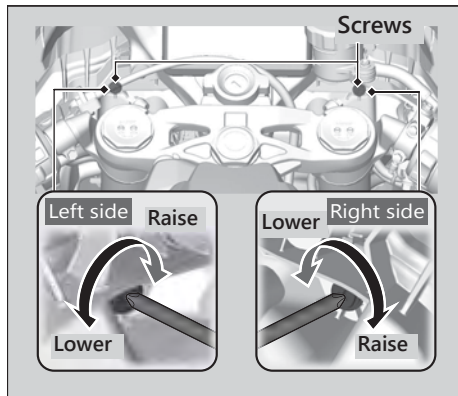

## Adjusting the Brake Lever

You can adjust the distance between the tip of the brake lever and handle grip.

### Adjustment method

Turn the adjuster until the numbers align with the index mark while pushing the lever forward in the desired position.

After adjustment, check that the lever operates correctly before riding.

#### NOTICE

Do not turn the adjuster beyond its natural limit.

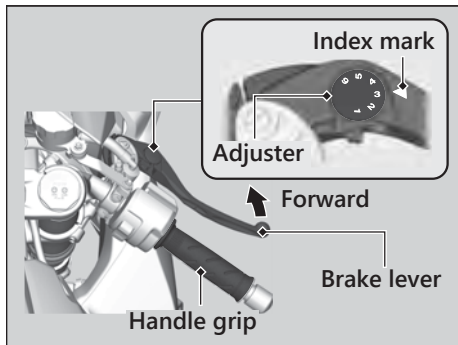

## Adjusting the Front Suspension

### Spring Preload

CBR1000RR/RA

You can adjust the spring preload by the adjuster to suit the load or the road surface. The spring preload adjuster has 15 turns. Turn clockwise to increase spring preload (hard), or turn counterclockwise to decrease spring preload (soft). The standard position is the 7 1/2 turns from the full soft position.

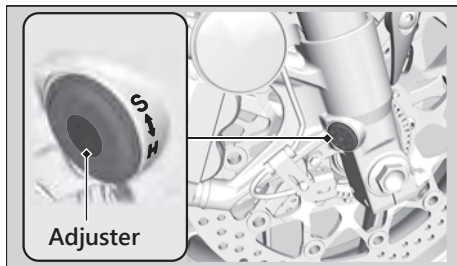

#### NOTICE

Do not turn the adjuster beyond its limits. Adjust both left and right forks to the same spring preload.

## Rebound Damping

### CBR1000RR/RA

You can adjust the rebound damping by the TEN adjuster to suit the load or the road surface.

The TEN adjuster has 5 1/2 turns.

Turn clockwise to increase rebound damping (hard), or turn counterclockwise to decrease rebound damping (soft). The standard position is 4 turns from the full hard position.

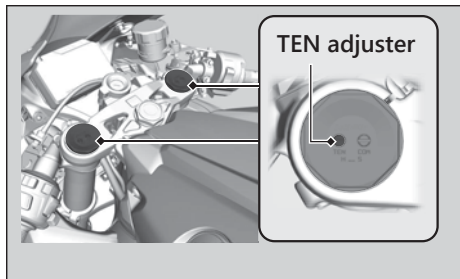

### NOTICE

Do not turn the adjuster beyond its limits. Adjust both left and right forks to the same rebound damping.

## Compression Damping

### CBR1000RR/RA

You can adjust the compression damping by the COM adjuster to suit the load or the road surface.

The COM adjuster has 7 turns.

Turn clockwise to increase compression damping (hard), or turn counterclockwise to decrease compression damping (soft). The standard position is 5 turns from the full hard position.

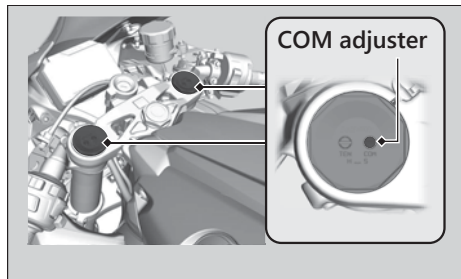

### NOTICE

Do not turn the adjuster beyond its limits.  
Adjust both left and right forks to the same compression damping.



## Adjusting the Rear Suspension

### Spring Preload

CBR1000RR/RA

You can adjust the spring preload by the adjuster to suit the load or the road surface. Turn the adjuster using the pin spanner. The preload adjuster has 9 positions. Positions 1 to 3 are for a decrease spring preload (soft), or turn the position 5 to 9 increase spring preload (hard). The standard position is 4.

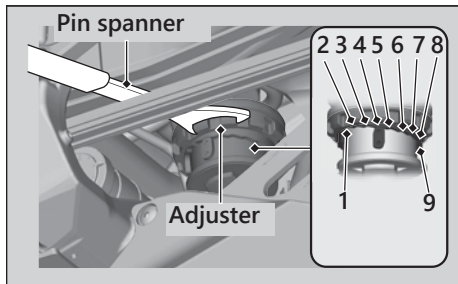

#### NOTICE

Do not turn the adjuster beyond its limits. Attempting to adjust directly from 1 to 9 or 9 to 1 may damage the shock absorber.

#### NOTICE

The rear shock absorber damper unit contains high pressure nitrogen gas. Do not attempt to disassemble, service, or improperly dispose of the damper. See your dealer.

## Rebound Damping

CBR1000RR/RA

You can adjust the rebound damping by the TEN adjuster to suit the load or the road surface.

The TEN adjuster has 4 turns.

Turn clockwise to increase rebound damping (hard), or turn counterclockwise to decrease rebound damping (soft).

The standard position is 2 1/2 turns from the full hard position.

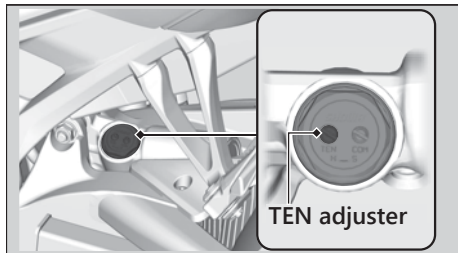

### NOTICE

Do not turn the adjuster beyond its limits.

### NOTICE

The rear shock absorber damper unit contains high pressure nitrogen gas. Do not attempt to disassemble, service, or improperly dispose of the damper. See your dealer.

## Compression Damping

CBR1000RR/RA

You can adjust the compression damping by the COM adjuster to suit the load or the road surface.

The COM adjuster has 4 1/2 turns.

Turn clockwise to increase compression damping (hard), or turn counterclockwise to decrease compression damping (soft).

The standard position is 3 turns from the full hard position.

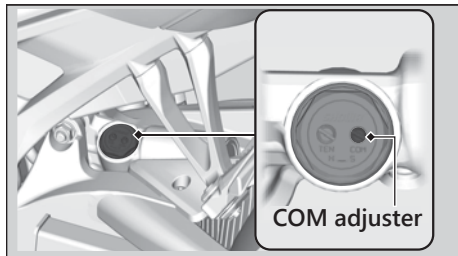

### NOTICE

Do not turn the adjuster beyond its limits.

### NOTICE

The rear shock absorber damper unit contains high pressure nitrogen gas. Do not attempt to disassemble, service, or improperly dispose of the damper. See your dealer.

## Adjusting the ÖHLINS Smart EC System

---

### CBR1000S1

This model is equipped with the ÖHLINS Smart EC system.

This system consists of front and rear suspension and Suspension Control Unit (SCU).

This system provides pre-programmed damping characteristics optimized for different situation for the front and rear suspension.

The front and rear suspension constantly determine riding conditions as the SCU receives signals from the different control units on the motorcycle. As a result, the

optimum rebound and compression damping force for road are provided.

The system continually adjusts compression and rebound damping levels according to the situation.

You can adjust the front and rear suspension preload manually.

ÖHLINS Smart EC is a trademark of ÖHLINS RACING AB, Sweden.

## Front Spring Preload

You can adjust the spring preload by the adjuster to suit the load or the road surface.

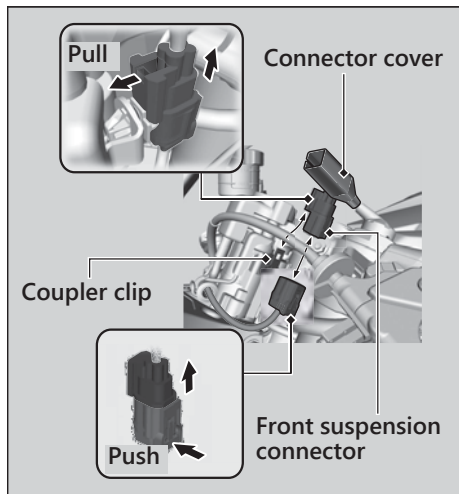

1. Make sure the ignition switch is in the OFF position. 2 P. 99
2. Slide the connector cover, and then disconnect the front suspension connector from the coupler clip.
3. Disconnect the front suspension connector.
  - U Do not remove by pulling on the wire harness.

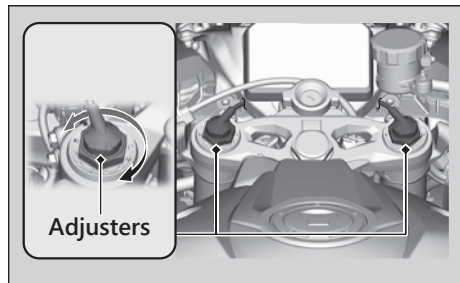

## Other Adjustments ⌋ Adjusting the ÖHLINS Smart EC System

4. Turn clockwise to increase spring preload (hard), or turn counterclockwise to decrease spring preload (soft).  
The standard position is the 4 turns from the full soft position.

### NOTICE

Do not turn the adjuster beyond its limits.  
Adjust both left and right forks to the same spring preload.

5. After the adjustment, connect the front suspension connector.
  - ⌋ Be careful not to allow water or dust to enter the connector.
  - ⌋ Make sure to install the connector completely.

6. Connect the front suspension connector to the coupler clip and then install the connector cover.

## Rear Spring Preload

You can adjust the spring preload by the adjuster knob to suit the load or the road surface.

Turn clockwise to increase spring preload (hard), or turn counterclockwise to decrease spring preload (soft).

The standard position is 8 turns from the full hard position.

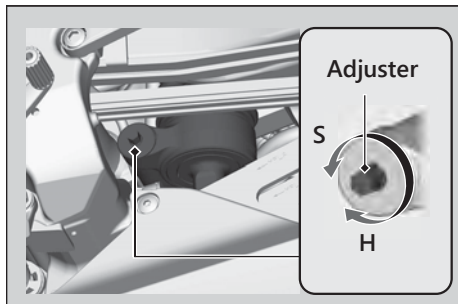

### NOTICE

Do not turn the adjuster beyond its limits.

### NOTICE

The rear shock absorber damper unit contains high pressure nitrogen gas. Do not attempt to disassemble, service, or improperly dispose of the damper. See your dealer.

## Damping Adjustment

You can select A-mode which automatically adjusts damping according to the riding situation and MANUAL mode which allows damping level to be set manually.

### A-mode

A-mode will automatically adjust compression and rebound damping levels individually for the front fork and rear suspension to provide desired change in behavior of the motorcycle.

A-mode provides 3 modes (A1, A2 and A3) with different riding feel and ride characteristics for various situations.

Defaults of A-mode can be adjusted using the ÖHLINS Objective Based Tuning interface (OBTi).

“OBTi” allows the rider to affect the characteristics.

Adjustable OBTi support items and riding situations for each A-mode are as follows.

A-mode	Situation	OBTi support items			
		BRAKE	ACC	CORNER	GENERAL
A1	track riding	A	A	A	A
A2	winding roads	A	N/A	N/A	A
A3	street riding	A	N/A	N/A	A

A : Adjustable

N/A : Not adjustable



**BRAKE:**

By adjusting the brake support objective it is possible to increase (+) or decrease (-) the pitching resistance during initial braking.

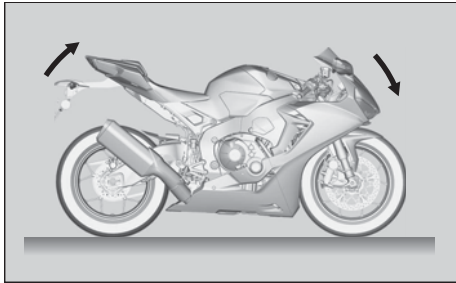

**ACC (A1 only):**

By adjusting the acceleration objective it is possible to increase (+) or decrease (-) the pitching resistance during accelerating.

**Direction**

(+): Motorcycle feels more stable especially during hard acceleration out of corner

(-): Useful to increase weight transfer to increase rear tire load

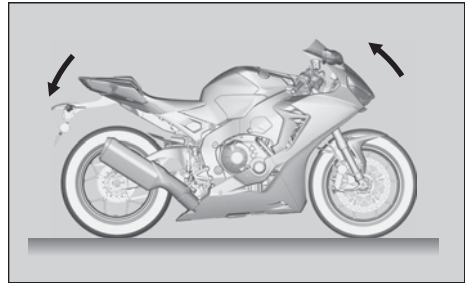

## Other Adjustments Adjusting the ÖHLINS Smart EC System

### CORNER (A1 only):

By adjusting the corner objective it is possible to increase (+) or decrease (-) the agile movements of the while turning.

#### Direction

(+): More agility especially in middle of corner.

(-): Good setting for rain or low grip condition.

### GENERAL:

By adjusting the firmness objective it is possible to increase (+) or decrease (-) the amount of overall damping levels.

#### Direction

For A1 mode

(+): Good for high grip tire and high road surface temperature.

(-): Good setting for rain or low grip condition.

For A2 and A3 mode

Tuning the objective more towards comfort

**To adjustment the "BRAKE", "ACC", "CORNER" and "GENERAL".**  P. 45

 P. 51

**To select the S mode.**  P. 102

## MANUAL mode

The suspension setting can be fixed at a certain value on compression and rebound damping of the front and rear suspensions.

The damping of front and rear suspension cannot be changed by riding behavior automatically.

MANUAL mode provides 3 modes (M1, M2 and M3).

Preset of M1 is suitable for track riding

Preset of M2 is suitable for winding roads

Preset of M3 is suitable for street riding

Each MANUAL mode allows the following damping level to be adjusted as desired:

FR COM: Compression damping for front suspension

FR REB: Rebound damping for front suspension

RR COM: Compression damping for rear suspension

RR REB: Rebound damping for rear suspension

**To adjust the “FR COM”, “FR REB”, “RR COM” and “RR REB”.** ≥ P. 45 ≥ P. 52

**To select the S mode.** ≥ P. 102

# Troubleshooting

<b>Engine Will Not Start</b> .....	P. 179	Burned-out Light Bulb .....	P. 194
<b>Overheating (High coolant temperature indicator is on)</b> .....	P. 180	Blown Fuse .....	P. 197
<b>Warning Indicators On or Flashing</b> .....	P. 181		
Low Oil Pressure Indicator .....	P. 181		
PGM-FI (Programmed Fuel Injection)			
Malfunction Indicator Lamp (MIL).....	P. 181		
ABS (Anti-lock Brake System) Indicator .....	P. 182		
HESD (Honda Electronic Steering Damper)			
Indicator .....	P. 182		
Torque Control Indicator.....	P. 183		
<b>Tire Puncture</b> .....	P. 184		
<b>Electrical Trouble</b> .....	P. 193		
Battery Goes Dead.....	P. 193		

### **Starter Motor Operates But Engine Does Not Start**

---

Check the following items:

- Check the correct engine starting sequence. 2 P. 108
- Check that there is gasoline in the fuel tank.
- Check if the PGM-FI malfunction indicator lamp (MIL) is on.
  - ⌋ If the indicator light is on, contact your dealer as soon as possible.

### **Starter Motor Does Not Operate**

---

Check the following items:

- Check the correct engine starting sequence. 2 P. 108
- Make sure engine stop switch is in the  (Run) position. 2 P. 98
- Check for a blown fuse. 2 P. 197
- Check for a loose battery connection or battery terminal corrosion. 2 P. 123, 2 P. 137
- Check the condition of the battery. 2 P. 193

If the problem continues, have your motorcycle inspected by your dealer.

## Overheating (High coolant temperature indicator is on)

The engine is overheating when the following occurs:

- High coolant temperature indicator comes on.
- Acceleration becomes sluggish. If this occurs, pull safely to the side of the road and perform the following procedure.

Extended fast idling may cause the high coolant temperature indicator to come on.

### NOTICE

Continuing to ride with an overheated engine can cause serious damage to the engine.

1. Stop the engine using the ignition switch, and then turn the ignition switch to the ON position.
2. Check that the radiator fan is operating, and then turn the ignition switch to the OFF position.  
**If the fan is not operating:**  
Suspect a fault. Do not start the engine. Transport your motorcycle to your dealer.  
**If the fan is operating:**  
Allow the engine to cool with the ignition switch in the OFF position.
3. After the engine has cooled, inspect the radiator hose and check if there is a leak.  $\geq$  P. 147  
**If there is a leak:**  
Do not start the engine. Transport your motorcycle to your dealer.
4. Check the coolant level in the reserve tank.  $\geq$  P. 147  
⊔ Add coolant as necessary.
5. If 1-4 check normal, you may continue riding, but closely monitor the high coolant temperature indicator.

### Low Oil Pressure Indicator

---

If the low oil pressure indicator comes on, pull safely to the side of the road and stop the engine.

#### NOTICE

Continuing to ride with low oil pressure can cause serious damage to the engine.

1. Check the engine oil level, and add oil as necessary.  $\geq$  P. 143,  $\geq$  P. 144
2. Start the engine.
  - ⌋ Only continue riding if the low oil pressure indicator goes off.

Rapid acceleration may momentarily cause the low oil pressure indicator to come on, especially if the oil is at or near the low level. If the low oil pressure indicator stays on when the oil level is at the proper level, stop the engine and contact your dealer.

If the engine oil level goes down rapidly, your motorcycle may have a leak or another serious problem. Have your motorcycle inspected by your dealer.

### PGM-FI (Programmed Fuel Injection) Malfunction Indicator Lamp (MIL)

---

If the indicator comes on while riding, you may have a serious problem with the PGM-FI system. Reduce speed and have your motorcycle inspected by your dealer as soon as possible.

## ABS (Anti-lock Brake System) Indicator

---

### CBR1000RA/S1

If the indicator operates in one of the following ways, you may have a serious problem with the ABS. Reduce your speed and have your motorcycle inspected by your dealer as soon as possible.

- Indicator comes on or starts flashing while riding.
- Indicator does not come on when the ignition switch is in the ON position.
- Indicator does not go off at speeds above 6 mph (10 km/h).

If the ABS indicator stays on, your brakes will continue to work as a conventional system, but without the anti-locking function.

The ABS indicator may flash if you turn the rear wheel while your motorcycle is lifted off the ground. In this case, turn the ignition switch to the OFF position, and then to the ON position again. The ABS indicator will go off after your speed reaches 19 mph (30 km/h).

## HESD (Honda Electronic Steering Damper) Indicator

---

If the indicator comes on while riding, you may have a serious problem with the HESD. Reduce speed and have your motorcycle inspected by your dealer as soon as possible.



## Torque Control Indicator

---

If the indicator operates in one of the following ways, you may have a serious problem with the Torque Control. Reduce your speed and have your motorcycle inspected by your dealer as soon as possible.

- Indicator comes and stays on (solid) while riding.
- Indicator does not come on when the ignition switch is turned to the ON position.
- Indicator does not go off at speeds above 3 mph (5 km/h).

Even when the Torque Control indicator is on, your motorcycle will have normal riding ability without Torque Control function.

-  When the indicator comes on while the Torque Control is in operation, you will

have to completely close the throttle to regain normal riding ability.

The Torque Control indicator may come on if you rotate the rear wheel while your motorcycle is lifted off the ground. In this case, turn the ignition switch to the OFF position, and then to the ON position again. The Torque Control indicator will go off after your speed reaches 3 mph (5 km/h).

### CBR1000RR

The Torque Control indicator come on when the front or rear wheel locks. In this case, the Torque Control will not function.

In this case, turn the ignition switch to the OFF position, and then to the ON position again. The Torque Control indicator will go off after your speed reaches 3 mph (5 km/h).

Repairing a puncture or removing a wheel requires special tools and technical expertise. We recommend you have this type of service performed by your dealer.

After an emergency repair, always have the tire inspected/replaced by your dealer.

### Emergency Repair Using a Tire Repair Kit

---

If your tire has a minor puncture, you can make an emergency repair using a tubeless tire repair kit.

Follow the instructions provided with the emergency tire repair kit.

Riding your motorcycle with a temporary tire repair is very risky. Do not exceed 30 mph (50 km/h). Have the tire replaced by your dealer as soon as possible.

### **3**WARNING

Riding your motorcycle with a temporary tire repair can be risky. If the temporary repair fails, you can crash and be seriously injured or killed.

If you must ride with a temporary tire repair, ride slowly and carefully and do not exceed 30 mph (50 km/h) until the tire is replaced.

### Removing Wheels

---

Follow these procedures if you need to remove a wheel in order to repair a puncture.

When removing and installing the wheel, be careful not to damage the wheel speed sensor and pulser ring.

## Front Wheel

### Removal

1. Place your motorcycle on a firm, level surface.
2. Cover the both side of the front wheel and brake caliper with protective tape or cloth.

CBR1000RR/RA

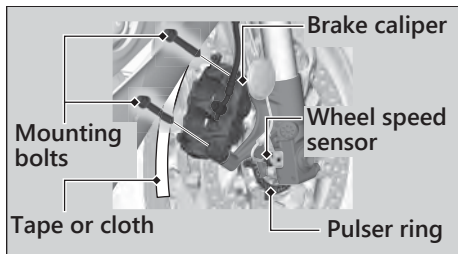

CBR1000S1

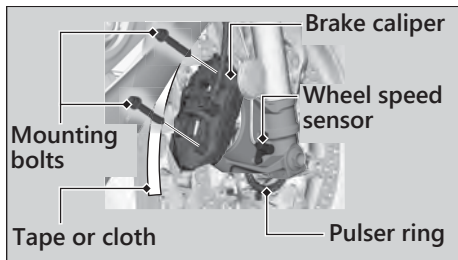

## Tire Puncture $\cup$ Removing Wheels

3. On the right side, remove the mounting bolts and remove the brake caliper.
4. On the left side, remove the mounting bolts and remove the brake caliper.
  - $\cup$  Support the brake caliper assembly so that it doesn't hang from the brake hose. Do not twist the brake hose.
  - $\cup$  Avoid getting grease, oil, or dirt on the disc or pad surfaces.
  - $\cup$  Do not pull the front brake lever while the brake caliper is removed.
  - $\cup$  Take care to prevent the brake caliper from scratching the wheel during removal.
5. Remove the front axle bolt.
6. Loosen the right axle pinch bolts.
7. Support your motorcycle securely and raise the front wheel off the ground using a maintenance stand or a hoist.

CBR1000RR/RA

Right side collar

Front axle bolt

Axle pinch bolts

CBR1000S1

Right side collar

Front axle bolt

Axle pinch bolts

8. Loosen the left axle pinch bolts.
9. On the left side, withdraw the front axle shaft, and remove the side collars and wheel.

CBR1000RR/RA

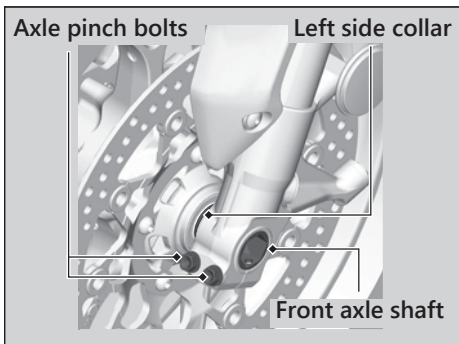

CBR1000S1

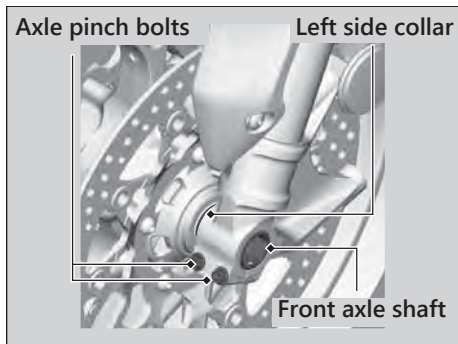

**Installation**

1. Attach the side collars to the wheel.
2. On the left side, place the wheel between the fork legs and insert the lightly greased front axle shaft to the end, through the left fork leg and wheel hub.
3. Align the end of the front axle shaft with the surface of the fork leg.

CBR1000RR/RA

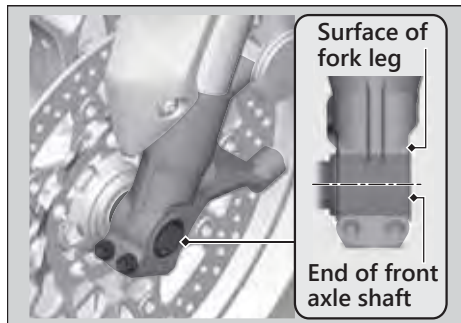

CBR1000S1

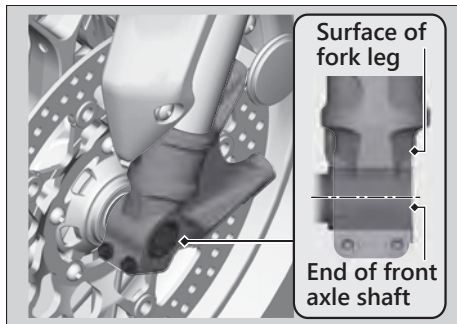

4. Tighten the left axle pinch bolts to hold the axle.
5. Tighten the axle bolt.

**Torque:** 58 lbf-ft (79 N·m, 8.1 kgf·m)

6. Loosen the left axle pinch bolts.
7. Tighten the right axle pinch bolts.

**Torque:** 16 lbf-ft (22 N·m, 2.2 kgf·m).

8. Install the right brake caliper and tighten the mounting bolts.

**CBR1000RR/RA**

**Torque:** 33 lbf·ft (45 N·m, 4.6 kgf·m).

**CBR1000S1**

**Torque:** 30 lbf·ft (40 N·m, 4.1 kgf·m).

9. Install the left brake caliper and tighten the mounting bolts.

**CBR1000RR/RA**

**Torque:** 33 lbf·ft (45 N·m, 4.6 kgf·m).

**CBR1000S1**

**Torque:** 30 lbf·ft (40 N·m, 4.1 kgf·m).

- U Take care to prevent the brake caliper from scratching the wheel during installation.
- U Use new mounting bolts when installing the brake caliper.

**NOTICE**

When installing a wheel or caliper into original position, carefully fit the brake disc between the pads to avoid scratching them.

10. Lower the front wheel on the ground.
11. Apply the brake lever several times. Then, pump the fork several times.
12. Retighten the left axle pinch bolts.

**Torque:** 16 lbf·ft (22 N·m, 2.2 kgf·m).

13. Raise the front wheel off the ground again, and check that the wheel rotates freely after you release the brake.
14. Uncover the protective tape or cloth.

If a torque wrench was not used for installation, see your dealer as soon as possible to verify proper assembly. Improper assembly may lead to loss of braking capacity.

## Rear Wheel

### Removal

1. Place your motorcycle on a firm, level surface.
2. Support your motorcycle securely and raise the rear wheel off the ground using a maintenance stand or a hoist.
3. Loosen the rear axle nut, lock nuts and turn the adjusting bolts so the rear wheel can be moved all the way forward for maximum drive chain slack..
4. Remove the rear axle nut and washer.

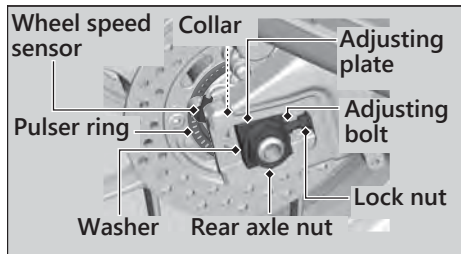

5. Remove the drive chain from the driven sprocket by pushing the rear wheel forward.
6. Remove the rear axle shaft, adjusting plates.

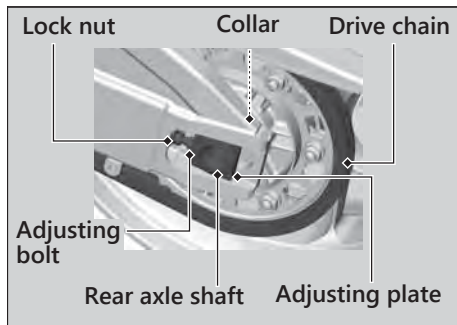



7. Remove the brake caliper bracket, rear wheel and side collars.
  - U Support the brake caliper assembly so that it doesn't hang from the brake hose. Do not twist the brake hose.
  - U Avoid getting grease, oil, or dirt on the disc or pad surfaces.
  - U Do not push the brake pedal while the wheel is removed.

## Installation

1. To install the rear wheel, reverse the removal procedure.
  - U Take care to prevent the brake caliper from scratching the wheel during installation.

### NOTICE

When installing a wheel or caliper into original position, carefully fit the brake disc between the pads to avoid scratching them.

2. Make sure that the lug on the brake caliper bracket is positioned in the slot on the swingarm.

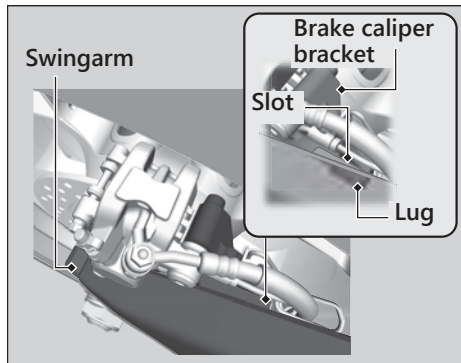

3. Adjust the drive chain. 2 P. 154
4. Install and tighten the rear axle nut.

**Torque:** 100 lbf-ft (135 N·m, 13.8 kgf·m).

5. After installing the wheel, apply the brake pedal several times, then check if the wheel rotates freely. Recheck the wheel if the brake drags or if the wheel does not rotate freely.

If a torque wrench was not used for installation, see your dealer as soon as possible to verify proper assembly. Improper assembly may lead to loss of braking capacity.

### Battery Goes Dead

---

#### CBR1000RR/RA

Charge the battery using a motorcycle battery charger.

Remove the battery from the motorcycle before charging.

Do not use an automobile-type battery charger, as these can overheat a motorcycle battery and cause permanent damage. If the battery does not recover after recharging, contact your dealer.

#### NOTICE

Jump starting using an automobile battery can damage your motorcycle's electrical system and is not recommended. Bump starting is also not recommended.

#### CBR1000S1

Battery charging is needed.

A battery charger recommended by your lithium-ion (li-ion) battery manufacturer is needed for battery charging.

Contact your dealer before charging the battery.

Remove the battery from the motorcycle before charging.

#### NOTICE

Only use a charger recommended by your lithium-ion (li-ion) battery manufacturer. Using a battery charger that is not recommended can cause permanent damage to your battery.

If the battery does not recover after recharging, contact your dealer.

#### NOTICE

Do not jump-start, as this can damage your motorcycle's electrical system and battery. Bump starting is not recommended.

## Burned-out Light Bulb

All light bulbs on the motorcycle are LEDs. If there is a LED which is not turned on, see your dealer for servicing.

## Headlights

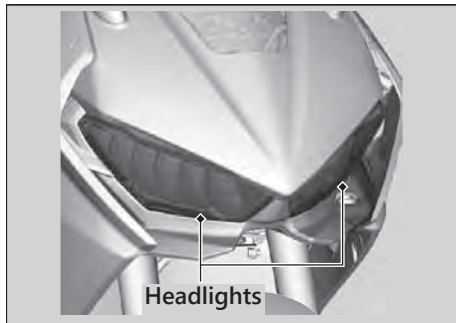

The headlights use several LEDs. If there is a LED which is not turned on, see your dealer for servicing.

## | Brake light/Taillight

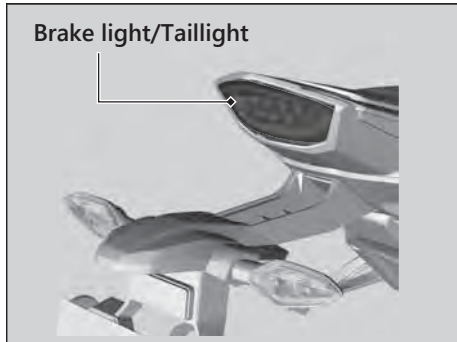

The brake light and taillight uses several LEDs.

If there is a LED which is not turned on, see your dealer for servicing.

## | Front Turn Signal Light

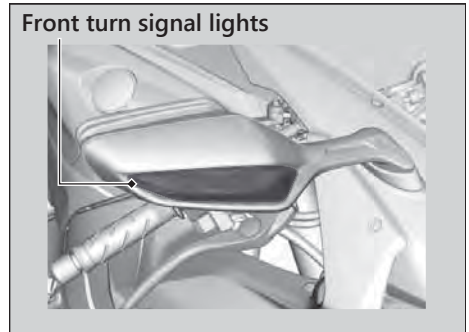

The front turn signal lights uses several LEDs. If there is a LED which is not turned on, see your dealer for servicing.

## Rear Turn Signal Light

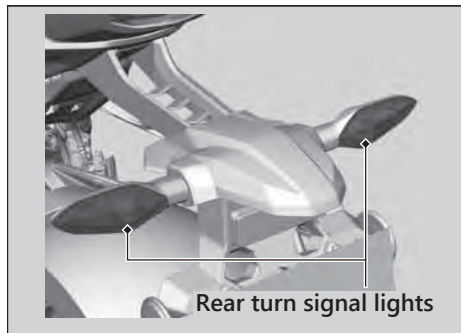

The rear turn signal lights uses several LEDs. If there is a LED which is not turned on, see your dealer for servicing.

## License Plate Light

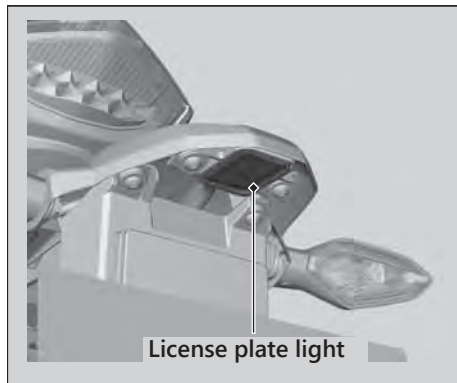

The license plate light uses a LED. If there is a LED which is not turned on, see your dealer for servicing.

## Blown Fuse

Before handling fuses, see “Inspecting and Replacing Fuses.” 2 P. 129

### ■ Fuse Box Fuses

1. Remove the front seat. 2 P. 139
2. Remove the fuse box cover.
3. Pull the fuses out one by one with the fuse puller in the tool kit and check for a blown fuse. Always replace a blown fuse with a spare fuse of the same rating.
4. Reinstall the fuse box cover.
5. Reinstall the front seat.

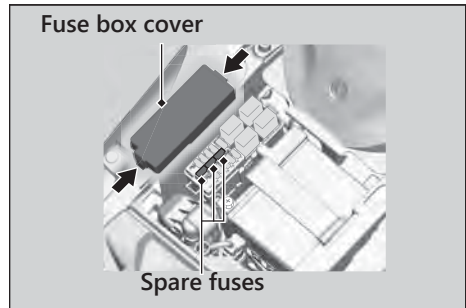

## Main Fuse & FI Fuse

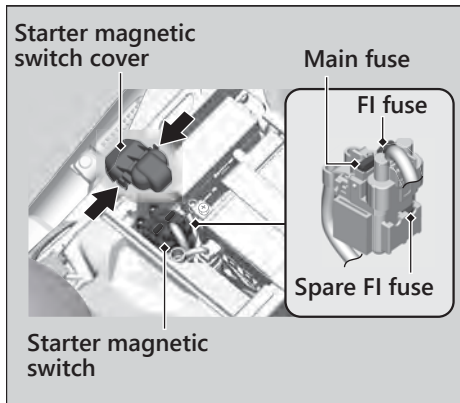

1. Remove the front seat. 2 P. 139
2. Remove the starter magnetic switch cover.
3. Pull the main fuse and FI fuse out one by one and check for a blown fuse. Always replace a blown fuse with a spare of the same rating.
  - U Spare main fuses are provided in the fuse box. 2 P. 197
4. Reinstall parts in the reverse order of removal.

### NOTICE

If a fuse fails repeatedly, you likely have an electrical problem. Have your motorcycle inspected by your dealer.



# Information

Keys.....	P. 200
Instruments, Controls, & Other Features...	P. 201
Caring for Your Motorcycle .....	P. 203
Storing Your Motorcycle .....	P. 207
Transporting Your Motorcycle.....	P. 208
You & the Environment .....	P. 209
Vehicle Identification Number.....	P. 210
Emission Control Systems .....	P. 211
Catalytic Converter .....	P. 215
Oxygenated Fuels.....	P. 216
Authorized Manuals .....	P. 217
Warranty Coverage and Service .....	P. 218
Honda Contacts .....	P. 220
<b>USA</b> Reporting Safety Defects .....	P. 222

## Keys

### Ignition Key

This motorcycle has two ignition keys and a key tag with a key number and a bar code. Store the spare key and the key tag in a safe location. To make a duplicate key, take the spare key and the key tag to your dealer or a locksmith. If you lose all keys and the key tag, the ignition switch assembly will probably have to be removed by your dealer to determine the key number.

A metal key holder may cause damage to the area surrounding the ignition switch.

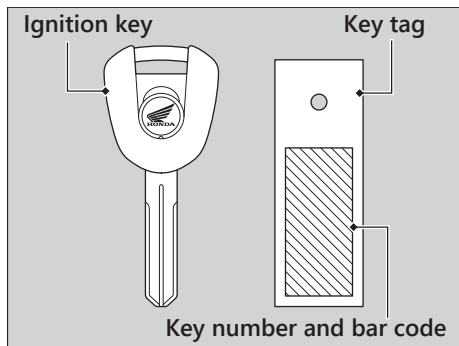

# Instruments, Controls, & Other Features

## Ignition Switch

Leaving the ignition switch in the ON position with the engine stopped will drain the battery.

Do not turn the key while riding.

## Engine Stop Switch

Do not use the engine stop switch except in an emergency. Doing so when riding will cause the engine to suddenly turn off, making riding unsafe.

If you stop the engine using the engine stop switch, turn the ignition switch to the OFF position. Failing to do so will drain the battery.

## Odometer

The display locks at 999,999 when the read-out exceeds 999,999.

## Tripmeter

The tripmeter A and B return to 0.0 when each read-out exceeds 9,999.9.

## Document Bag

### CBR1000RR/RA

The owner's manual, registration, and insurance information can be stored in the plastic document bag on the underside of the rear seat. 2 P. 139

### CBR1000S1

The owner's manual, registration, and insurance information can be stored in the plastic document bag on the underside of the single seat cowl. 2 P. 141

### Ignition Cut-off System

A banking (lean angle) sensor automatically stops the engine and fuel pump if the motorcycle falls over. To reset the sensor, you must turn the ignition switch to the OFF position and back to the ON position before the engine can be restarted.

### HESD

The Honda Electronic Steering Damper (HESD) automatically controls the steering damper characteristics in accordance with vehicle speed and acceleration.

**HESD Indicator Comes On** 2 P. 182

### Assist-slipper Clutch System

The assist-slipper clutch system helps to prevent the rear tire from locking up when the deceleration of your motorcycle produces a strong engine braking effect. It also makes the clutch lever operation feel lighter.

Use only MA classification engine oil for your motorcycle. Using engine oil other than MA classification oil could result in damage to the assist-slipper clutch system.

### Throttle by Wire System

This model is equipped with a Throttle by Wire System.

Do not put magnetized items or items susceptible to magnetic interference near the right handlebar switches.

## Automatic Brightness Control

The backlight brightness of the meter will be controlled automatically when “AUTO” is selected on the brightness setting.

Ambient brightness is detected by the photosensor.

Do not damage or cover the photosensor. Otherwise, the automatic brightness control may not work properly.

**Photosensor**

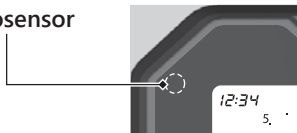

## Caring for Your Motorcycle

Frequent cleaning and polishing is important to ensure the life of your Honda. A clean motorcycle makes it easier to spot potential problems.

In particular, seawater and salts used to prevent ice on roads promote the formation of corrosion. Always wash your motorcycle thoroughly after riding on coastal or treated roads.

### Washing

Allow the engine, muffler, brakes, and other high-temperature parts to cool before washing.

1. Rinse your motorcycle thoroughly using a low pressure garden hose to remove loose dirt.
2. If necessary, use a sponge or a soft towel with mild cleaner to remove road grime.
  - ↳ Clean the windscreen, headlight lens, panels, and other plastic components with extra care to avoid scratching them.

## Caring for Your Motorcycle

Avoid directing water into the air cleaner, muffler, and electrical parts.

3. Thoroughly rinse your motorcycle with plenty of clean water and dry with a soft, clean cloth.
4. After the motorcycle dries, lubricate any moving parts.
  - ⌋ Make sure that no lubricant spills onto the brakes or tires. Brake discs, pads, drum or shoes contaminated with oil will suffer greatly reduced braking effectiveness and can lead to a crash.
5. Lubricate the drive chain immediately after washing and drying the motorcycle.
6. Apply a coat of wax to prevent corrosion.
  - ⌋ Avoid products that contain harsh detergents or chemical solvents. These can damage the metal, paint, and plastic on your motorcycle. Keep the wax clear of the tires and brakes.
  - ⌋ If your motorcycle has any matte painted parts, do not apply a coat of wax to the matte painted surface.

## Washing Precautions

Follow these guidelines when washing:

- Do not use high-pressure washers:
  - ⌋ High-pressure water cleaners can damage moving parts and electrical parts, rendering them inoperable.
  - ⌋ Water in the air intake can be drawn into the throttle body and/or enter the air cleaner.
- Do not direct water at the muffler:
  - ⌋ Water in the muffler can prevent starting and causes rust in the muffler.
- Dry the brakes:
  - ⌋ Water adversely affects braking effectiveness. After washing, apply the brakes intermittently at low speed to help dry them.
- Do not direct water under the seat:
  - ⌋ Water in the under seat compartment can damage your documents and other belongings.

- **CBR1000S1**

Do not direct water under the single seat cowl:

- ⊔ Water in the under single seat cowl compartment can damage your documents and other belongings.

- Do not direct water at the air cleaner:

- ⊔ Water in the air cleaner can prevent the engine from starting.

- Do not direct water near the headlight:

- ⊔ The headlight's inside lens may fog temporarily after washing or while riding in the rain. This does not impact the headlight function.

However, if you see a large amount of water or ice accumulated inside the lens(es), have your vehicle inspected by your dealer.

- Do not use wax or polishing compounds on matte painted surface:

- ⊔ Use a soft cloth or sponge, plenty of water, and a mild detergent to clean matte painted surfaces. Dry with a soft clean cloth.

### Aluminum Components

Aluminum will corrode from contact with dirt, mud, or road salt. Clean aluminum parts regularly and follow these guidelines to avoid scratches:

- Do not use stiff brushes, steel wool, or cleaners containing abrasives.
- Avoid riding over or scraping against curbs.

### Panels

Follow these guidelines to prevent scratches and blemishes:

- Wash gently using a soft sponge and plenty of water.
- To remove stubborn stains, use diluted detergent and rinse thoroughly with plenty of water.
- Avoid getting gasoline, brake fluid, or detergents on the instruments, panels, or headlight.

### Windscreen

Using plenty of water, clean the windscreen with a soft cloth or sponge. (Avoid using detergents or any kind of chemical cleaner on the windscreen.) Dry with a soft, clean cloth.

#### NOTICE

To avoid possible scratching or other damage, use only water and a soft cloth or sponge to clean the windscreen.

For a dirtier windscreen, use a diluted neutral detergent with a sponge and plenty of water. Make sure to wash off all the detergent. (Detergent residue may cause windscreen cracks.)

Replace the windscreen if scratches cannot be removed and they obstruct clear vision.

Take care to keep battery electrolyte, brake fluid, or other chemical solvents off the windscreen and screen garnish. They will damage the plastic.



## Exhaust Pipe and Muffler

The exhaust pipe and muffler are titanium and stainless steel but may become stained by mud or dust.

To remove mud or dust, use a wet sponge and a liquid kitchen abrasive, then rinse well with clean water. Dry with chamois or a soft towel.

If necessary, remove heat stains by using a commercially available fine texture compound. Then rinse by the same manner as removing mud or dust.

### NOTICE

Even though the exhaust is made of titanium and stainless steel, it can become stained. Remove all marks and blemishes as soon as they are noticed.

## Storing Your Motorcycle

If you store your motorcycle outdoors, you should consider using a full-body motorcycle cover.

If you won't be riding for an extended period, follow these guidelines:

- Wash your motorcycle and wax all painted surfaces (except matte painted surfaces). Coat chrome pieces with rust-inhibiting oil.
- Lubricate the drive chain. 2 P. 131
- Place your motorcycle on a maintenance stand and position a block so that both tires are off the ground.
- After rain, remove the body cover and allow the motorcycle to dry.

## Transporting Your Motorcycle

- Remove the battery (2 P. 137) to prevent discharge. Charge the battery in a shaded, well-ventilated area.
  - ⌋ If you leave the battery in place, disconnect the negative - terminal to prevent discharge.

After removing your motorcycle from storage, inspect all maintenance items required by the Maintenance Schedule.

**USA** For more information about storage, refer to the *Honda Winter Storage Guide*, available from your dealer.

**Canada** For more information about storage, visit our website at [www.honda.ca](http://www.honda.ca) and look up “Storage Tips” under the “Honda Warranty” in the Warranty tab for your Model.

## Transporting Your Motorcycle

If your motorcycle needs to be transported, it should be carried on a motorcycle trailer or a flatbed truck or trailer that has a loading ramp or lifting platform, and motorcycle tie-down straps. Never try to tow your motorcycle with a wheel or wheels on the ground.

### NOTICE

Towing your motorcycle can cause serious damage to the transmission.

## You & the Environment

Owning and riding a motorcycle can be enjoyable, but you must do your part to protect the environment.

### Choose Sensible Cleaners

Use a biodegradable detergent when you wash your motorcycle. Avoid aerosol spray cleaners that contain chlorofluorocarbons (CFCs) which damage the atmosphere's protective ozone layer.

### Recycle Wastes

Put oil and other toxic wastes in approved containers and take them to a recycling center. Call your local or state office of public works or environmental services to find a recycling center in your area, and to get instructions on how to dispose of non-recyclable wastes. Do not place used engine oil in the trash, or pour it down a drain or on the ground. Used oil, gasoline,

coolant, and cleaning solvents contain poisons that can hurt refuse workers and contaminate drinking water, lakes, rivers, and oceans.

## Vehicle Identification Number

The VIN and engine serial number uniquely identify your motorcycle and are required in order to register your motorcycle. They may also be required when ordering replacement parts.

You should record these numbers and keep them in a safe place.

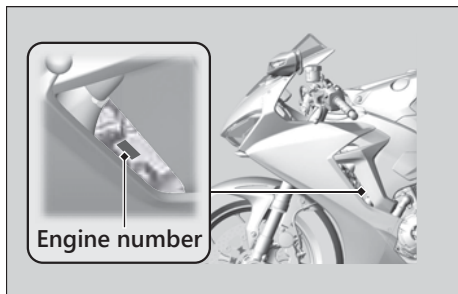
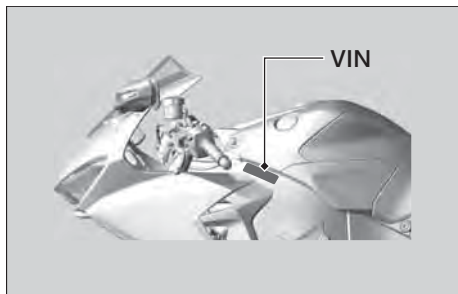
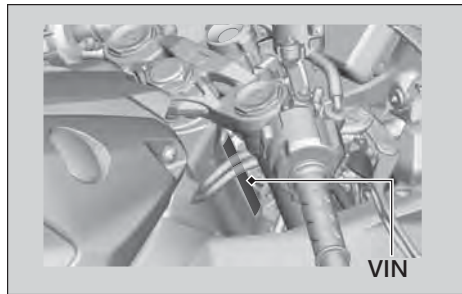

## Emission Control Systems

Your motorcycle engine emits combustion byproducts, including carbon monoxide (CO), oxides of nitrogen (NO<sub>x</sub>), and hydrocarbons (HC). Gasoline evaporation also emits hydrocarbons. Controlling the production of NO<sub>x</sub>, CO, and HC is important for the environment.

### Exhaust Emission Requirements

The U.S. Environmental Protection Agency (EPA), the California Air Resources Board (CARB), and Environment and Climate Change Canada (ECCC) require that your motorcycle comply with applicable exhaust, crankcase, and fuel permeation emission standards during its useful life, when operated and maintained according to the instructions provided. CARB also requires that your motorcycle comply with applicable evaporative emission requirements during its useful life, when

operated and maintained according to the instructions provided.

**USA** Compliance with the terms of the Distributor's Warranties for Honda Motorcycle Emission Control Systems is necessary in order to maintain a valid emissions system warranty.

The Vehicle Emission Control Information label is located on the left side of the swingarm.

### Canada Vehicle emission control information label

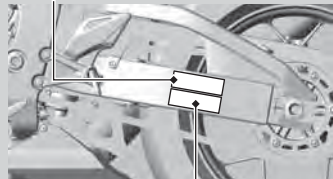

Vehicle emission control information label

### Noise Emission Requirements

The EPA requires that motorcycles built after January 1, 1983 comply with applicable noise emission standards for one year or 3,730 miles (6,000 km) after the time of purchase when operated and maintained according to the instructions provided.

### Exhaust Emission Control System

The exhaust emission control system includes the following components that should not need adjustment, although periodic inspection by your dealer is recommended.

#### PGM-FI System

The PGM-FI (programmed fuel injection) system uses sequential multiport fuel injection, and is comprised of air intake, engine control, fuel control, and exhaust control subsystems. The engine control module (ECM) uses sensors to determine how much air enters the engine, and then controls how much fuel to inject.

#### Ignition Timing Control System

The ignition timing control system adjusts the ignition timing to reduce the amount of HC, CO, and NO<sub>x</sub> produced.

#### Secondary Air Injection System

The secondary air injection system adds filtered air into the exhaust gas to help improve emission control performance.

#### Catalytic Converters

The exhaust system contains one or more catalytic converters. Catalytic converters use a catalyst to convert most of the harmful exhaust gas compounds into harmless compounds.

### Evaporative Emission Control System

#### 50 STATE (meets California)

An evaporative emissions control system uses a canister filled with charcoal to adsorb fuel vapor from the fuel tank while the engine is off. The vapor is drawn into the engine and burned while riding.

### **Crankcase Emissions Control System**

The engine is equipped with a closed crankcase system to prevent discharging crankcase emissions into the atmosphere.

Blow-by gas is returned to the combustion chamber through the air cleaner and the intake manifold.

### **Fuel Permeation Emission Control**

The fuel tank, fuel hoses, and fuel vapor charge hoses use fuel permeation control technologies to prevent fuel vapor emissions. Tampering with these components to reduce or defeat the effectiveness of the fuel permeation technologies is prohibited.

### **Noise Emission Control System**

#### **■ TAMPERING WITH THE NOISE CONTROL SYSTEM IS PROHIBITED:**

U. S. federal law prohibits, and Canadian provincial laws may prohibit, the following acts or the causing thereof: (1) The removal or rendering inoperative by any person, other than for purposes of maintenance, repair or replacement, of any device or element of design incorporated into any new vehicle for the purpose of noise control prior to its sale or delivery to the ultimate purchaser or while it is in use; or (2) the use of the vehicle after such device or element of design has been removed or rendered inoperative by any person.

### **AMONG THOSE ACTS PRESUMED TO CONSTITUTE TAMPERING ARE THE FOLLOWING ACTS:**

- Removal of, or puncturing the muffler, baffles, header pipes or any other component which conducts exhaust gases.
- Removal of, or puncturing of any part of the intake system.
- Lack of proper maintenance.
- Removing or disabling any emissions compliance component, or replacing any compliance component with a noncompliant component.

### **Problems Affecting Motorcycle Exhaust Emissions**

Have your motorcycle inspected and repaired by your dealer if you experience any of the following symptoms:

- Hard starting or stalling after starting
- Rough idling
- Misfiring or backfiring during acceleration
- Poor engine performance and poor fuel economy



## Catalytic Converter

This motorcycle is equipped with a three-way catalytic converter. The catalytic converter contains precious metals that serve as catalysts in high temperature chemical reactions that convert hydrocarbons (HC), carbon monoxide (CO), and oxides of nitrogen (NOx) in the exhaust gasses into safe compounds.

A defective catalytic converter contributes to air pollution and can impair your engine's performance. A replacement unit must be an original Honda part or equivalent.

Follow these guidelines to protect your motorcycle's catalytic converter.

- Always use unleaded gasoline. Leaded gasoline will damage the catalytic converter.
- Keep the engine in good running condition. A poorly running engine can cause the catalytic converter to overheat causing damage to the converter or the motorcycle.
- If your engine is misfiring, backfiring, stalling, or otherwise not running properly, stop riding and turn off the engine. Have your motorcycle serviced as soon as possible.

## Oxygenated Fuels

Some conventional fuels blended with alcohol or an ether compound are available in some locales to help reduce emissions to meet clean air standards. These gasolines are collectively referred to as oxygenated fuels. If you plan to use oxygenated fuel, check that it is unleaded and meets the minimum octane rating and blend requirement.

The following fuel blends are EPA-approved and have been approved for use in your motorcycle:

- Ethanol (ethyl alcohol) up to 10% by volume.
  - Gasoline containing ethanol may be marketed under the name Gasohol.
- Methanol (methyl alcohol) up to 5% by volume that contain cosolvents and corrosion inhibitors to protect the fuel system. Never use a blend containing more than 5%.

If you accidentally fill your fuel tank with an oxygenated fuel containing higher percentages,

you may experience performance problems. To resolve the problem, have your dealer drain the fuel tank and replace with the correct fuel. Fuel system or performance problems resulting from the use of an oxygenated fuel containing higher percentages are not covered by your warranty.

### NOTICE

Improper use of oxygenated fuels can damage metal, rubber, and plastic parts of your fuel system.

Oxygenated fuel can also damage paint.

Damage caused by spilled fuel is not covered by warranty.

If you notice any undesirable operating symptoms or performance problems, try a different brand of gasoline.

## Authorized Manuals

**USA** The Service Manual used by your authorized dealer is available from your Honda dealer or Helm, Inc.

**Canada** See your dealer to order authorized manuals.

Also available, but not necessary to service your model, is the Honda Common Service Manual, which explains basic service information for various systems on Honda motorcycles, scooters, and ATV.

**USA** The Winter Storage Guide in conjunction with the Owner's Manual and Service Manual

can help you prepare your Honda motorcycle, scooter, ATV, and SxS for winter storage. These Honda manuals are written for the professional technician. However, if you possess the proper tools, observe the safety standards, and are mechanically capable, you should find them easy to use.

Special Honda tools are necessary for some procedures.

**USA**

**Order On-Line: [www.helminc.com](http://www.helminc.com)**

**Order Toll Free: 1-888-CYCLE93**

(1-888-292-5393)

(NOTE: For Credit Card Orders Only)

Monday - Friday 8:00 AM - 6:00 PM EST

Publication Item No.	Description
61MKF00	2017 CBR1000RR/RA/S1/S2 Service Manual
61CSM00	Common Service Manual
S9507	<b>USA</b> Winter Storage Guide
31MKF600	2017 CBR1000RR/RA/S1 Owner's Manual

## Warranty Coverage and Service

### Coverage

Your new Honda is covered by the following warranties:

- Motorcycle Limited Warranty
- Emission Control System Warranty
- **USA** Noise Control Warranty

The responsibilities, restrictions, and exclusions that apply to these warranties are explained in the Warranties Booklet given to you by your Honda dealer at the time of purchase. Always keep your Honda owner's card with your Warranties Booklet.

**Canada** Please refer to the Warranty Booklet posted on our website at [www.honda.ca](http://www.honda.ca).

It is important to realize that your warranty applies only to defects in material or workmanship of your Honda. Your warranty

coverage does not apply to the normal wear and deterioration associated with use of the motorcycle.

Your warranty coverage is not voided if you perform your own maintenance. However, failures that occur due directly to improper maintenance are not covered by these warranties.

**USA** You can extend almost all of your warranty coverage through the Honda Protection Plan. For more information, see your Honda dealer.

### Service

Please remember that maintenance recommended in the Maintenance Schedule is not included in your warranty coverage.

If you believe you have a problem with your motorcycle, call the service department of your Honda dealer. Make an appointment for an inspection and diagnosis. You will be asked to authorize that inspection, and your dealer will return the results of the inspection. If a problem exists and is covered under warranty, your dealer will perform the warranty repairs. If you have any questions about your warranty coverage or the nature of the repair, talk to the Service Manager of your Honda dealer.

If a misunderstanding occurs and you aren't satisfied with your dealer's handling of the situation, we suggest you discuss your problem with the appropriate member of the dealership's management team. If you are still

not satisfied, contact the owner of the dealership or their designated representative.

## Honda Contacts

### American Honda Motor Co., Inc.

If you wish to contact Honda directly to comment on your experiences with your motorcycle or with your dealer, please send your comments to the following address:

Motorcycle Division,  
American Honda Motor Co., Inc.,  
P.O. Box 2200, Torrance,  
CA 90509-2200  
Mailstop: 100-4C-7B,  
Telephone: (866) 784-1870.

### Canada

Honda Canada Inc.  
Customer Relations Department,  
180 Honda Boulevard  
Markham, Ontario  
L6C 0H9  
Telephone: (888) 946-6329

Fax: (877) 939-0909

E-mail: [honda\\_cr@ch.honda.com](mailto:honda_cr@ch.honda.com)

Please include the following information in your letter:

- Name, address, and telephone number
- Product model, year, and VIN
- Date of purchase
- Dealer name and address

We will likely ask your Honda dealer to respond, or possibly acknowledge your comments directly.

## Your Honda Dealer

The service department of your Honda dealer offers trained personnel to perform regular maintenance and most repairs. It has the latest available service information from Honda and also handles warranty inspections and repairs. The parts department offers Honda Genuine Parts, Pro Honda products, Honda Genuine Accessories (USA only), and Honda accessories and products (Canada only) that provide the same quality that went into your motorcycle.

**USA** The sales department offers the Honda Protection Plan to extend almost all of your warranty coverage.

Your Honda dealer can also supply information about, riding events, and information about safety training available in your local area, and the Honda Rider's Club of America (USA only).

## Honda Rider's Club of America (HRCA)

The Honda Rider's Club of America (HRCA) sponsors local riding chapters at Authorized Honda Dealerships across the country.

## **USA** Reporting Safety Defects

If you believe that your vehicle has a defect which could cause a crash or could cause injury or death, you should immediately inform the National Highway Traffic Safety Administration (NHTSA) in addition to notifying American Honda Motor Co., Inc.

If NHTSA receives similar complaints, it may open an investigation, and if it finds that a safety defect exists in a group of vehicles, it may order a recall and remedy campaign. However, NHTSA cannot become involved in individual problems between you, your dealer, or American Honda Motor Co., Inc.

To contact NHTSA, you may call the Vehicle Safety Hotline toll-free at:

1-888-327-4236

(TTY: 1-800-424-9153); go to

*<http://www.safercar.gov>;*

or write to:

Administrator, NHTSA,  
1200 New Jersey Avenue, SE.,  
Washington, DC 20590.

You can also obtain other information about motor vehicle safety from:

*<http://www.safercar.gov>.*



# Specifications

## ■ Main Components

Overall length	81.3 in (2,065 mm)	
Overall width	28.3 in (720 mm)	
Overall height	44.3 in (1,125 mm)	
Wheelbase	55.3 in (1,405 mm)	
Minimum ground clearance	5.1 in (130 mm)	
Caster angle	23.3°	
Trail	3.8 in (96 mm)	
Curb weight	<b>CBR1000RR</b> <b>49 STATE</b>	430 lb (195 kg)
	<b>CBR1000RR</b> <b>50 STATE (meets California)</b>	432 lb (196 kg)
	<b>CBR1000RA</b>	434 lb (197 kg)
	<b>CBR1000S1</b>	432 lb (196 kg)
	<b>CBR1000RR/RA</b> *1	366 lb (166 kg)
Maximum weight capacity	<b>CBR1000S1</b> *2	243 lb (110 kg)
	<b>CBR1000RR/RA</b>	Rider and 1 passenger
Passenger capacity	<b>CBR1000S1</b>	Rider only (no passenger)
		10.5 ft (3.20 m)
Minimum turning radius	10.5 ft (3.20 m)	
Displacement	61.0 cu-in (1,000 cm <sup>3</sup> )	
Bore x stroke	2.99 x 2.17 in (76.0 x 55.1 mm)	
Compression ratio	13.0:1	

Fuel	Unleaded gasoline Recommended: 91 PON or higher	
Tank capacity	4.28 US gal (16.2 L)	
Battery	<b>CBR1000RR/RA</b> YTZ7S 12V-6Ah (10 HR)	
	<b>CBR1000S1</b> HY93 lithium-ion (li-ion) 12V-4.5Ah (20 HR)	
Gear ratio	1st	2.285
	2nd	1.777
	3rd	1.500
	4th	1.333
	5th	1.214
	6th	1.137
Reduction ratio (primary / final)	1.717 / 2.688	

\*1 : Including rider, passenger, all luggages, and accessories

\*2 : Including rider, all luggages, and accessories

## Specifications

### ■ Service Data

Tire size	Front	120/70ZR17M/C (58W)
	Rear	190/50ZR17M/C (73W)
Tire type	Radial, tubeless	
Recommended Tires	Front	<b>CBR1000RR/RA</b> BRIDGESTONE S21F E DUNLOP D214F Y
		<b>CBR1000S1</b> BRIDGESTONE RS10F N PIRELLI DIABLO SUPERCORSA SP
		<b>CBR1000RR/RA</b> BRIDGESTONE S21R E DUNLOP D214 Y
	Rear	<b>CBR1000RR/RA</b> BRIDGESTONE RS10R N PIRELLI DIABLO SUPERCORSA SP
		<b>CBR1000S1</b> BRIDGESTONE RS10R N PIRELLI DIABLO SUPERCORSA SP
		<b>CBR1000S1</b> PIRELLI DIABLO SUPERCORSA SP
Tire air pressure	Front	36 psi (250 kPa, 2.50 kgf/cm <sup>2</sup> )
	Rear	42 psi (290 kPa, 2.90 kgf/cm <sup>2</sup> )
Minimum tread depth	Front	0.06 in (1.5 mm)
	Rear	0.08 in (2.0 mm)
Spark plug	(standard)	IMR9E-9HES (NGK) or VUH27ES (DENSO)
Spark plug gap	0.03 - 0.04 in (0.8 - 0.9 mm)	
Idle speed	1,200 ± 100 rpm	

Recommended engine oil	API Service Classification SG or higher except oils labeled as energy conserving or resource conserving on the circular API service label, SAE 10W-30, JASO T 903 standard MA, ProHonda GN4 4-stroke oil (USA & Canada) or Honda 4-stroke oil, or an equivalent motorcycle oil	
	After draining	2.6 US qt (2.5 L)
Engine oil capacity	After draining & engine oil filter change	2.9 US qt (2.7 L)
	After disassembly	3.6 US qt (3.4 L)
Recommended brake fluid	Honda DOT 4 Brake Fluid	
Cooling system capacity	2.94 US qt (2.78 L)	
Recommended coolant	Pro Honda HP Coolant	
Recommended drive chain lubricant	Pro Honda HP Chain Lube or equivalent lubricant	
Drive chain slack	1.0 - 1.4 in (25 - 35 mm)	

Standard drive chain	RK525ROZ7	
	No. of links	116
Standard sprocket size	Drive sprocket	16T
	Driven sprocket	43T

### ■ Bulbs

Headlight	LED
Brake light/Taillight	LED
Front turn signal light	LED
Rear turn signal light	LED
License plate light	LED

### ■ Fuses

Main fuse	30A
Other fuse	<b>CBR1000RR</b> 20A, 15A, 10A
	<b>CBR1000RA/S1</b> 30A, 20A, 15A, 10A

### ■ Torque Specifications

Engine oil drain bolt	22 lbf-ft (30 N·m, 3.1 kgf·m)
Oil filter	19 lbf-ft (26 N·m, 2.7 kgf·m)
Front wheel axle bolt	58 lbf-ft (79 N·m, 8.1 kgf·m)
Front wheel brake caliper mounting bolt	<b>CBR1000RR/RA</b> 33 lbf-ft (45 N·m, 4.6 kgf·m)
	<b>CBR1000S1</b> 30 lbf-ft (40 N·m, 4.1 kgf·m)
Front wheel axle pinch bolt	16 lbf-ft (22 N·m, 2.2 kgf·m)
Rear wheel axle nut	100 lbf-ft (135 N·m, 13.8 kgf·m)

## Information Record

VIN	
Engine No.	
Color Label & Code	
Owner's Name	
Address	
City/State	
Phone	
Dealer's Name	
Address	
City/State	
Phone	
Service Manager	

- A**
- ABS (Anti-lock Brake System)..... 13
  - ABS (Anti-lock Brake System) Indicator ..... 94, 182
  - Accessories ..... 16
- B**
- Background ..... 63
  - Battery ..... 123, 137
  - Battery Voltage ..... 40
  - Blank Display ..... 41
  - Brake Light Switch..... 151
  - Brakes
    - Fluid ..... 130, 149
    - Lever Adjustment..... 163
    - Pad Wear ..... 150
  - Braking ..... 12
  - Brightness ..... 62, 203
  - Bulb
    - Brake light/Taillight ..... 195
    - Front Turn Signal ..... 195
    - Headlights ..... 194
    - License Plate Light..... 196
    - Rear Turn Signal..... 196
- C**
- Caring for Your Motorcycle ..... 203
  - Catalytic Converter..... 215
  - CBR Logo ..... 40
  - Circuit Mode ..... 24
  - Clear Data ..... 57
  - Clock ..... 22
  - Clutch System..... 157
  - Coolant ..... 132, 147
  - Coolant Temperature Gauge ..... 26
- D**
- Damping Adjustment ..... 174
  - Date..... 41
  - Date & Time ..... 70
  - Display
    - Background ..... 63
    - Brightness ..... 62
    - Display Mode ..... 59
    - Favorite..... 65
    - Shift Indicator ..... 61
    - User Letter ..... 64
  - Drive Chain..... 153
  - DTC..... 84

- E**
- EB Value** ..... 103
  - Electrical Trouble** ..... 193
  - Engine**
    - Number ..... 210
    - Oil ..... 129, 143
    - Oil Filter ..... 145
    - Overheats ..... 180
    - Starting ..... 108
    - Stop Switch ..... 99, 108, 201
    - Stopping ..... 201
    - Will Not Start ..... 179
  - Environment** ..... 209
  - Equipment**
    - Owner's Manual ..... 112, 201
    - Tool Kit ..... 112
- F**
- Failure** ..... 92
  - Favorite** ..... 65
  - Flooded Engine** ..... 108
  - Front Seat** ..... 139
  - Front Suspension** ..... 164
  - Fuel**
    - Recommended ..... 111
    - Tank Capacity ..... 111
  - Fuel Mileage Meter** ..... 75
  - Function**
    - Quick Shifter ..... 46
    - Suspension A1, A2 and A3 ..... 51
    - Suspension M1, M2 and M3 ..... 52
  - Fuses** ..... 129, 197
- G**
- Gasohol** ..... 216
  - Gasoline** ..... 111
  - Gear Position Indicator** ..... 23
  - General**
    - Date & Time ..... 70
    - Restore Default ..... 76
    - Units ..... 71
- H**
- Hazard Switch** ..... 98
  - Headlight Aim** ..... 162
  - Headlight Dimmer Switch** ..... 98
  - Helmet Holder** ..... 112
  - Helpfu** ..... 91

<b>HESD (Honda Electronic Steering Damper)</b> .....	95, 182
<b>High Beam Indicator</b> .....	94
<b>High Coolant Temperature Indicator</b> .....	94, 180
<b>Honda Contacts</b> .....	220
<b>Horn Button</b> .....	98

## I

<b>Ignition Cut-off System</b>	
Banking Sensor .....	202
Side Stand .....	152
<b>Ignition Key</b> .....	200
<b>Ignition Switch</b> .....	99, 108, 201
<b>Indicators</b> .....	93
<b>INFO 1 Display</b> .....	28
<b>INFO 2 Display</b> .....	31
<b>INFO 3 Display</b> .....	39
<b>Information Record</b> .....	226
<b>Instruments</b> .....	22

## L

<b>Labels</b> .....	8
<b>LAP Button</b> .....	24, 98

<b>Lap Data</b> .....	56
<b>Lap Time</b>	
Clear Date .....	57
Lap Date .....	56
<b>Lap Timer</b> .....	24, 86
<b>Left Turn Signal Indicator</b> .....	93
<b>Lithium-Ion Battery</b> .....	125
<b>Load Limits</b> .....	17
<b>Loading Guidelines</b> .....	17
<b>Low Fuel Indicator</b> .....	94
<b>Low Oil Pressure Indicator</b> .....	93, 181

## M

<b>Maintenance</b>	
Fundamentals .....	120
Importance .....	115
Safety .....	116
Schedule .....	117
<b>Maximum Weight Limit</b> .....	17
<b>Mechanic Mode</b> .....	60
<b>Mileage</b> .....	73
<b>Modifications</b> .....	16
<b>Multi-Information Display</b> .....	23, 25

<b>N</b>	
Neutral Indicator .....	94
<b>O</b>	
Odometer.....	29, 201
ÖHLINS Smart EC System.....	170
Oil	
Engine .....	129, 143
Overheating .....	180
Oxygenated Fuels.....	216
<b>P</b>	
P Value .....	103
Parking .....	14
Parts Location.....	18
Passing Light Control Switch.....	98
PGM-FI (Programmed Fuel Injection)	
Malfunction Indicator Lamp (MIL)....	95, 181
Photosensor.....	203
Pop-up Information	
Failure .....	92
Helpful .....	91
Maintenance .....	91
Protective Apparel.....	10
<b>Q</b>	
Quick Shifter .....	46, 84, 110
Quick Shifter Indicator .....	23
<b>R</b>	
Rear Seat.....	140
Rear Suspension .....	167
Recommended	
Coolant.....	132
Fuel.....	111
Oil .....	129
Refueling .....	111
Removal	
Battery .....	137
Front Seat .....	139
Rear Seat.....	140
Single Seat Cowl .....	141
Under Cowl .....	142
Repair Kit .....	184
Reporting Safety Defects.....	222
Restore Default .....	76
Riding Mode.....	101, 102
Riding Precautions .....	12
Right Turn Signal Indicator .....	93



<b>S</b>	
<b>S Mode</b> .....	103
<b>Safety Labels</b> .....	8
<b>Safety Precautions</b> .....	10
<b>Service</b>	
DTC .....	84
Maintenance .....	80
Quick Shifter .....	84
Sports Kit ECU .....	85
Suspension .....	83
<b>Setting Mode</b>	
Display .....	42, 58
Function .....	42, 45
General .....	42, 69
Lap Time .....	42, 55
Service .....	42, 79
Sports Kit .....	42
<b>Shift Indicator</b> .....	61
<b>Shift Indicator Set Value</b> .....	40
<b>Shift Indicators</b> .....	93, 96
<b>Shifting Gears</b> .....	109
<b>Side Stand</b> .....	152
<b>Side Stand Ignition Cut-off System</b> .....	152
<b>Specifications</b> .....	223
<b>Speedometer</b> .....	73
<b>Speedometer</b> .....	22
<b>Sports Kit ECU</b> .....	85
<b>Start Button</b> .....	99, 108
<b>Starting the Engine</b> .....	108
<b>Stopping Engine</b> .....	201
<b>Storage</b>	
Equipment .....	112
Owner's Manual .....	112, 201
Tool Kit .....	112
<b>Storing Your Motorcycle</b> .....	207
<b>Street Mode</b> .....	22
<b>Suspension</b> .....	83
<b>Suspension A1, A2 and A3</b> .....	51
<b>Suspension M1, M2 and M3</b> .....	52
<b>Switches</b> .....	98
<b>T</b>	
<b>T Value</b> .....	103
<b>Tachometer</b> .....	22, 22
<b>Temperature</b> .....	74
<b>Throttle</b> .....	161, 202
<b>Throttle Grip Angle</b> .....	40

**Tires**

Air Pressure .....	133
Puncture.....	184
Replacing.....	135, 184
<b>Torque Control Indicator</b> .....	93
<b>Torque Control OFF Indicator</b> .....	93
<b>Transporting Your Motorcycle</b> .....	208
<b>Tripmeter</b> .....	29, 201
<b>Troubleshooting</b> .....	178
<b>Turn Signal Switch</b> .....	98

**U**

<b>Units</b> .....	71
<b>User Letter</b> .....	41, 64

**V**

<b>Vehicle Identification Number</b> .....	210
--	-----

**W**

<b>Warranty Coverage and Service</b> .....	218
<b>Washing Your Motorcycle</b> .....	203
<b>Weight Limit</b> .....	17

**Wheels**

Front Removal.....	185
--------------------	-----

Rear Removal.....	190
-------------------	-----