

Contents

Motorcycle Safety P. 2

Operation Guide P. 16

Maintenance P. 30

Troubleshooting P. 76

Information P. 99

Specifications P. 120

Index P. 124

Welcome

Congratulations on your purchase of a new Honda motorcycle. Your selection of a Honda makes you part of a worldwide family of satisfied customers who appreciate Honda's reputation for building quality into every product.

To ensure your safety and riding pleasure:

- Read this owner's manual carefully.
- Follow all recommendations and procedures contained in this manual.
- Pay close attention to safety messages contained in this manual and on the motorcycle.

To protect your investment, we urge you to take responsibility for keeping your motorcycle well serviced and maintained. Also, observe the break-in guidelines, and always perform the pre-ride inspection and other periodic checks in this manual.

When service is required, remember that your Honda dealer knows your motorcycle best. If you have the required mechanical "know-how" and tools, you can purchase an official Honda Service Manual to help you perform many maintenance and repair tasks.

➤ [P. 115](#)

Read the warranty information thoroughly so that you understand the warranty coverage and that you are aware of your rights and responsibilities. ➤ [P. 116](#)

You may also want to visit our website at www.powersports.honda.com.

Canada www.honda.ca.

Happy riding!

California Proposition 65 Warning

WARNING: This product contains or emits chemicals known to the State of California to cause cancer and birth defects or other reproductive harm.

A Few Words About Safety

Your safety, and the safety of others, is very important. Operating this motorcycle safely is an important responsibility.

To help you make informed decisions about safety, we have provided operating procedures and other information on safety labels and in this manual. This information alerts you to potential hazards that could hurt you or others.

Of course, it is not practical or possible to warn you about all hazards associated with operating or maintaining a motorcycle. You must use your own good judgment.

You will find important safety information in a variety of forms, including:

- Safety labels on the motorcycle
- Safety Messages preceded by a safety alert symbol and one of three signal words: DANGER, WARNING, or CAUTION.

These signal words mean:

3 DANGER

You **WILL** be **KILLED** or **SERIOUSLY HURT** if you don't follow instructions.

3 WARNING

You **CAN** be **KILLED** or **SERIOUSLY HURT** if you don't follow instructions.

3 CAUTION

You **CAN** be **HURT** if you don't follow instructions.

Other important information is provided under the following titles:

NOTICE Information to help you avoid damage to your motorcycle, other property, or the environment.

Motorcycle Safety

This section contains important information for safe riding of your motorcycle.
Please read this section carefully.

Safety Guidelines	P. 3
Safety Labels	P. 7
Safety Precautions	P. 9
Riding Precautions	P. 10
Accessories & Modifications	P. 13
Loading	P. 14

Safety Guidelines

Follow these guidelines to enhance your safety:

- Perform all routine and regular inspections specified in this manual.
- Stop the engine and keep sparks and flame away before filling the fuel tank.
- Do not run the engine in enclosed or partly enclosed areas. Carbon monoxide in exhaust gases is toxic and can kill you.

Always Wear a Helmet

It's a proven fact: helmets and protective apparel significantly reduce the number and severity of head and other injuries. So always wear an approved motorcycle helmet and protective apparel. ➔ P. 9

Before Riding

Make sure that you are physically fit, mentally focused and free of alcohol and drugs. Check that you and your passenger are both wearing an approved motorcycle helmet and protective apparel. Instruct your passenger on holding onto the seat strap or your waist, leaning with you in turns, and keeping their feet on the footpegs, even when the motorcycle is stopped.

Take Time to Learn & Practice

Even if you have ridden other motorcycles, practice riding in a safe area to become familiar with how this motorcycle works and handles, and to become accustomed to the motorcycle's size and weight.

Safety Guidelines

We recommend that all riders take a certified course approved by the Motorcycle Safety Foundation (MSF). New riders should start with the basic course, and even experienced riders will find the advanced course beneficial. For information about the MSF training course nearest you, call the national toll-free number: (800) 446-9227.

USA Other riding tips can be found in the You and Your Motorcycle Riding Tips booklet that came with your motorcycle.

Ride Defensively

Always pay attention to other vehicles around you, and do not assume that other drivers see you. Be prepared to stop quickly or perform an evasive maneuver.

Make Yourself Easy to See

Make yourself more visible, especially at night, by wearing bright reflective clothing, positioning yourself so other drivers can see you, signaling before turning or changing lanes, and using your horn when necessary.

Ride within Your Limits

Never ride beyond your personal abilities or faster than conditions warrant. Fatigue and inattention can impair your ability to use good judgment and ride safely.

Don't Drink and Ride

Alcohol and riding don't mix. Even one alcoholic drink can reduce your ability to respond to changing conditions, and your reaction time gets worse with every additional drink. Don't drink and ride, and don't let your friends drink and ride either.

Keep Your Honda in Safe Condition

It's important to keep your motorcycle properly maintained and in safe riding condition. Inspect your motorcycle before every ride and perform all recommended maintenance. Never exceed load limits (➤ P. 14), and do not modify your motorcycle or install accessories that would make your motorcycle unsafe (➤ P. 13).

If You are Involved in a Crash

Personal safety is your first priority. If you or anyone else has been injured, take time to assess the severity of the injuries and whether it is safe to continue riding. Call for emergency assistance if needed. Also follow applicable laws and regulations if another person or vehicle is involved in the crash.

If you decide to continue riding, first evaluate the condition of your motorcycle. If the engine is still running, turn it off. Inspect for fluid leaks,

check the tightness of critical nuts and bolts, and check the handlebar, control levers, brakes, and wheels. Ride slowly and cautiously. Your motorcycle may have suffered damage that is not immediately apparent. Have your motorcycle thoroughly checked at a qualified service facility as soon as possible.

Carbon Monoxide Hazard

Exhaust contains poisonous carbon monoxide, a colorless, odorless gas. Breathing carbon monoxide can cause loss of consciousness and may lead to death.

If you run the engine in confined or even partly enclosed area, the air you breathe could contain a dangerous amount of carbon monoxide. Never run your motorcycle inside a garage or other enclosure.

3 WARNING

Carbon monoxide gas is toxic.
Breathing it can cause
unconsciousness and even kill you.

Avoid any areas or activities that
expose you to carbon monoxide.

Safety Labels

Safety and information labels on your motorcycle provide important safety information and may warn you of potential

hazards that could cause serious injury. Read these labels carefully and don't remove them. If a label comes off or becomes hard to read, contact your dealer for a replacement.

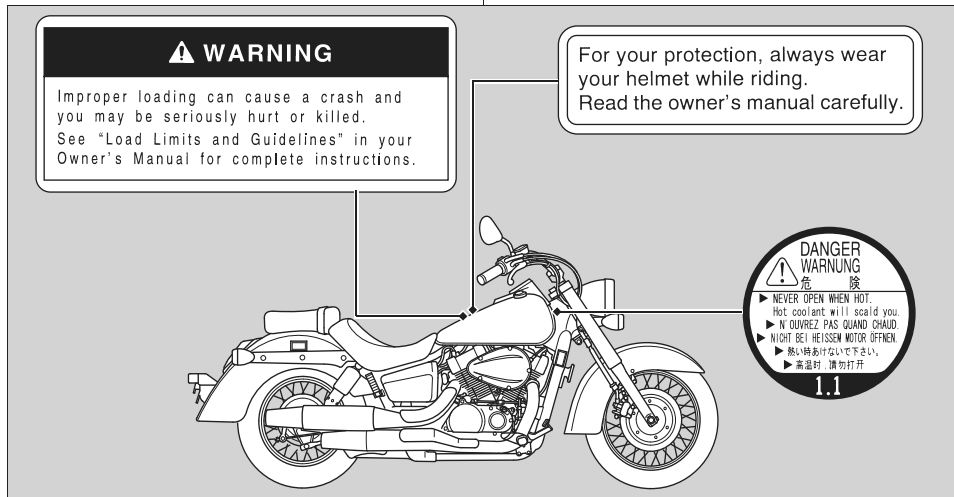

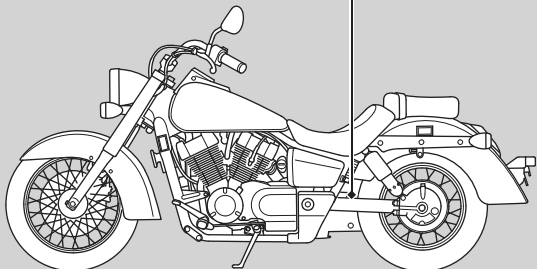

TIRE INFORMATION		
Cold tire pressures :		
[Up to maximum weight capacity]		
Front	200kPa 2.00kg/cm ² 29psi	
Rear	250kPa 2.50kg/cm ² 36psi	
[Up to 90kg(200lbs) load]		
Front	200kPa 2.00kg/cm ² 29psi	
Rear	200kPa 2.00kg/cm ² 29psi	
Maximum weight capacity : 182kg(401lbs)		
Tire size : Front 120/90-17M/C 64S		
Rear 160/80-15M/C 74S		
Tire brand	Front	Rear
DUNLOP	D404FG	D404
BRIDGESTONE	G701	G702
CHENG SHIN	M6002	M6011R
Min. recommend tire center tread depth.		
	Front 1.5mm(0.06in.)	Rear 2.0mm(0.08in.)
Read owner's manual.		

Safety Precautions

- Ride cautiously and keep your hands on the handlebar and feet on the footpegs.
- Keep passenger's hands on to the seat strap or your waist, passenger's feet on the footpegs while riding.
- Always consider the safety of your passenger, as well as other drivers and riders.

Protective Apparel

Make sure that you and any passenger are wearing an approved motorcycle helmet, eye protection, and high-visibility protective clothing. Ride defensively in response to weather and road conditions.

■ Helmet

Should be safety-standard certified, high-visibility, and correct size for your head

- Must fit comfortably but securely, with the chin strap fastened

- Face shield with unobstructed field of vision or other approved eye protection

USA Look for a DOT (Department of Transportation) certification label on any helmet you buy.

3 WARNING

Not wearing a helmet increases the chance of serious injury or death in a crash.

Make sure that you and any passenger always wear an approved helmet and protective apparel.

■ Gloves

Full-finger leather gloves with high abrasion resistance

Riding Precautions

Boots or Riding Shoes

Sturdy boots with non-slip soles and ankle protection

Jacket and Pants

Protective, highly visible, long-sleeved jacket and durable long pants for riding (or a protective suit).

Riding Precautions

Break-in Period

During the first 300 miles (500 km) of running, follow these guidelines to ensure your motorcycle's future reliability and performance.

- Avoid full-throttle starts and rapid acceleration.
- Avoid hard braking and rapid down-shifts.
- Ride conservatively.

Brakes

Observe the following guidelines:

- Avoid excessively hard braking and down-shifts.
 - ▶ Sudden braking can reduce the motorcycle's stability.
 - ▶ Where possible, reduce speed before turning; otherwise you risk sliding out.

- Exercise caution on low traction surfaces.
 - ▶ The tires slip more easily on such surfaces and braking distances are longer.
- Avoid continuous braking.
 - ▶ Repeated braking, such as when descending long, steep slopes can seriously overheat the brakes, reducing their effectiveness. Use engine braking with intermittent use of the brakes to reduce speed.
- For full braking effectiveness, operate both the front and rear brakes together.

■ Combined ABS (VT750CS only)

Your motorcycle's rear brake system is linked to the front brake. This means that operating the rear brake pedal applies the rear brake and a portion of the front brake. Operating the front brake lever applies only the front brake. For full braking effectiveness, operate both the front and rear brakes together.

This model is also equipped with an Anti-lock Brake System (ABS) designed to help prevent the brakes from locking up during hard braking.

- ABS does not reduce braking distance. In certain circumstances, ABS may actually result in a longer stopping distance.
- ABS does not function at speeds below 6 mph (10 km/h).
- The brake lever and pedal may recoil slightly when applying the brakes. This is normal.
- Always use the recommended tires to ensure correct ABS operation.

Riding Precautions

Engine Braking

Engine braking helps slow your motorcycle down when you release the throttle. For further slowing action, downshift to a lower gear. Use engine braking with intermittent use of the brakes to reduce speed when descending long, steep slopes.

Wet or Rainy Conditions

Road surfaces are slippery when wet, and wet brakes further reduce braking efficiency. Exercise extra caution when braking in wet conditions.

If the brakes get wet, apply the brakes while riding at low speed to help them dry.

Parking

- Park on a firm, level surface.
- If you must park on a slight incline or loose surface, park so that the motorcycle cannot move or fall over.

- Make sure that high-temperature parts cannot come into contact with flammable materials.
- Do not touch the engine, muffler, brakes and other high-temperature parts until they cool down.
- To reduce the likelihood of theft, always lock the handlebar and remove the key when leaving the motorcycle unattended. Use of an anti-theft device is also recommended.

Parking with the Side Stand

1. Stop the engine.
2. Push the side stand down.
3. Slowly lean the motorcycle to the left until its weight rests on the side stand.
4. Turn the handlebar fully to the left.
 - ▶ Turning the handlebar to the right reduces stability and may cause the motorcycle to fall.
5. Turn the steering lock to the lock position and remove the key. ➤ P. 23

Refueling and Fuel Guidelines

Follow these guidelines to protect the engine and catalytic converter:

- Use only unleaded gasoline.
- Use recommended octane number. Using lower octane gasoline will result in decreased engine performance.
- Do not use fuels containing a high concentration of alcohol. ➤ [P. 114](#)
- Do not use stale or contaminated gasoline or an oil/gasoline mixture.
- Avoid getting dirt or water in the fuel tank.

Accessories & Modifications

We strongly advise that you do not add any accessories that were not specifically designed or approved for your motorcycle by Honda or make modifications to your motorcycle from its original design. Doing so can make it unsafe. Modifying your motorcycle may also void your warranty and make your motorcycle illegal to operate on public roads and highways. Before deciding to install accessories on your motorcycle be certain the modification is safe and legal.

3 WARNING

Improper accessories or modifications can cause a crash in which you can be seriously hurt or killed.

Follow all instructions in this owner's manual regarding accessories and modifications.

Do not pull a trailer with, or attach a sidecar to, your motorcycle. Your motorcycle was not designed for these attachments, and their use can seriously impair your motorcycle's handling.

Loading

- Carrying extra weight affects your motorcycle's handling, braking and stability. Always ride at a safe speed for the load you are carrying.
- Avoid carrying an excessive load and keep within specified load limits.
 - **Maximum weight capacity / Maximum luggage weight** P. 120
- Tie all luggage securely, evenly balanced and close to the center of the motorcycle.
- Do not place objects near the lights or the muffler.

3 WARNING

Overloading or improper loading can cause a crash and you can be seriously hurt or killed.

Follow all load limits and other loading guidelines in this manual.

Parts Location

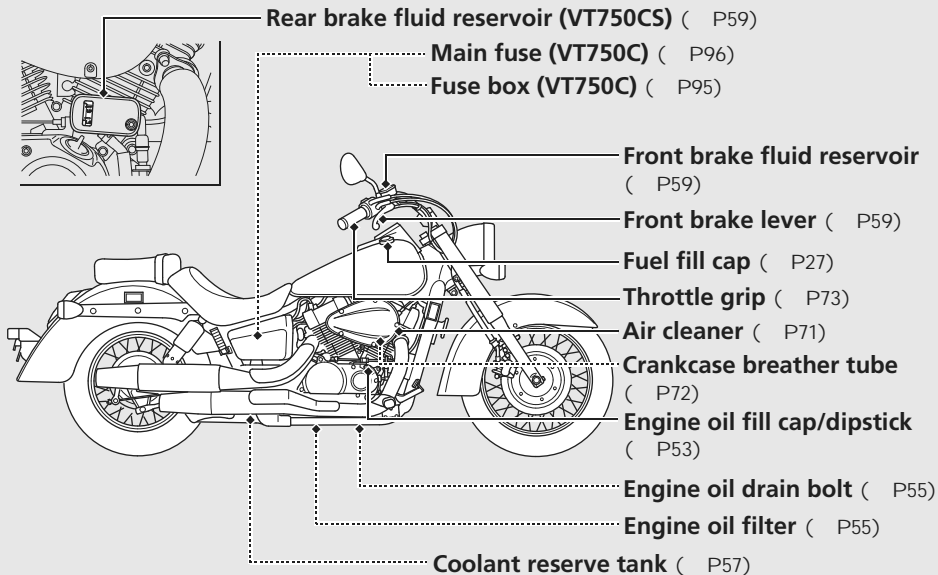

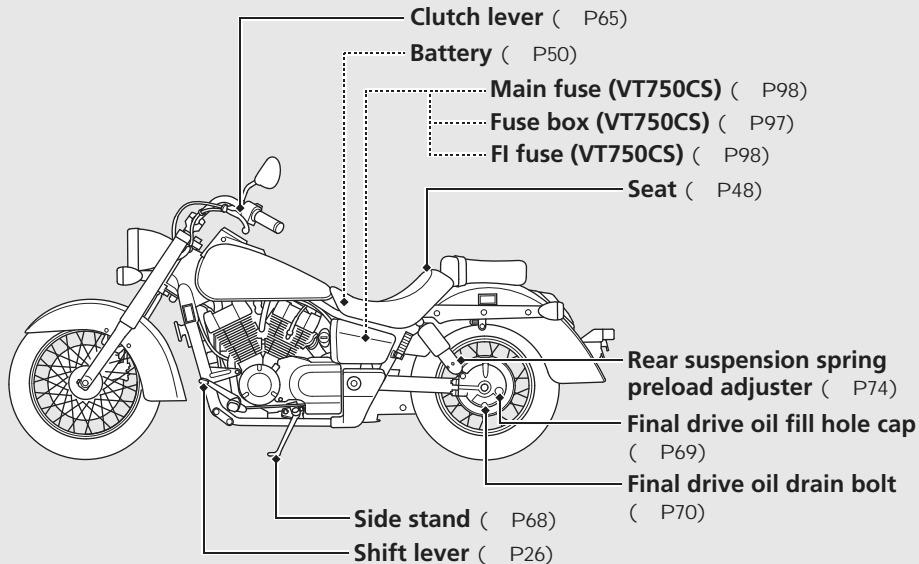

Instruments

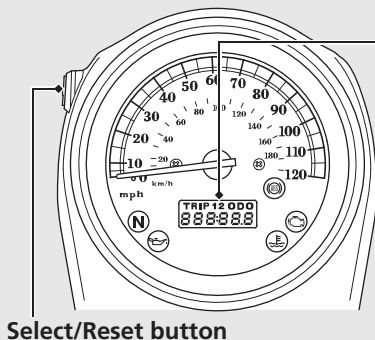

TRIP 12 ODO
888:88.8

Odometer [ODO], Tripmeter [TRIP 1/2] & Clock
Select/Reset button switches between odometer, tripmeters & clock.

- Odometer: Total distance ridden.
- Tripmeter: Distance ridden since tripmeter was reset (press and hold Select/Reset button to reset to 0.0 mile/km).

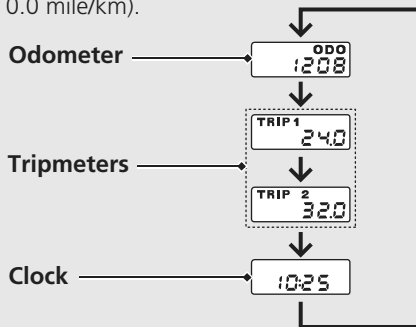

To set the clock:

- !a Turn the ignition switch on.
- !b Select the digital clock mode.
- !c Press and hold the Select/Reset button until the hour digits start flashing.

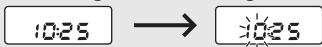

- !d Press the Select/Reset button until the desired hour is displayed.

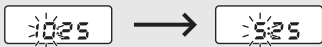

- !e Press and hold the Select/Reset button. The minute digits start flashing.

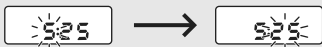

- !f Press the Select/Reset button until the desired minute is displayed.



- !g Press and hold the Select/Reset button until the display stops flashing. The clock is set.
 - ▶ The time can also be set by turning the ignition switch off.
 - ▶ The display will stop flashing automatically and the adjustment will be cancelled if the button is not pressed for about 30 seconds.

Indicators

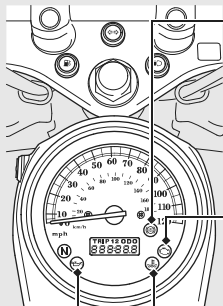

ABS (Anti-lock Brake System) indicator (VT750CS)

Comes on when the ignition switch is turned on.
Goes off when your speed reaches approximately 6 mph (10 km/h).

If it comes on while riding: (P80)



PGM-FI (Programmed Fuel Injection) malfunction indicator lamp (MIL)

Comes on briefly when the ignition switch is turned on with the engine stop switch in the  (Run) position.

If it comes on while engine is running: (P79)



High coolant temperature indicator

If it comes on while riding: (P78)



Low oil pressure indicator

Comes on when the ignition switch is turned on.
Goes off when the engine starts.

If it comes on while engine is running: (P79)

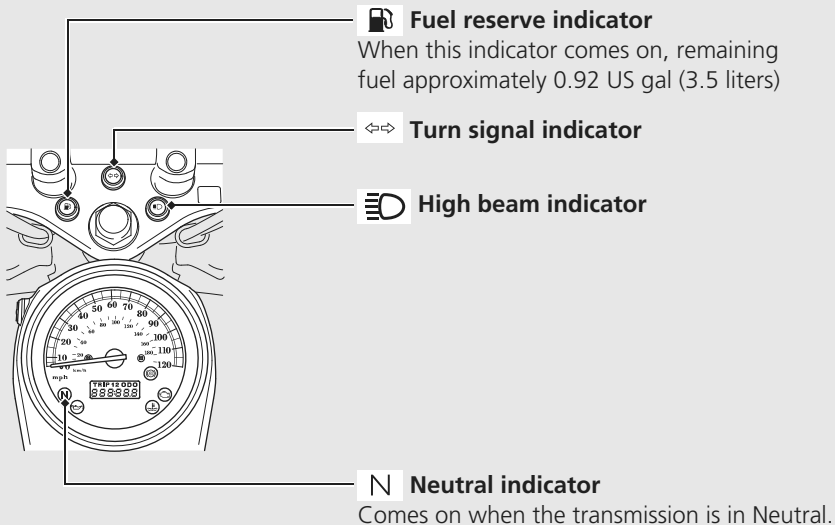

Switches

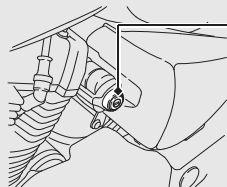
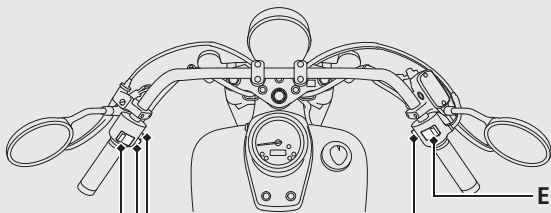



 **Horn button**

 **Turn signal switch**

▶ Pressing the switch turns the turn signal off.

Headlight dimmer switch

- : High beam
- : Low beam

Engine stop switch

Should normally remain in the  (Run) position.

▶ In an emergency, switch to the  (Off) position (the starter motor will not operate) to stop the engine.

 **Start button**

Headlight turns off when operating the starter motor.

Ignition Switch

Switches the electrical system on/off.

- ▶ Key can be removed when in the OFF position.

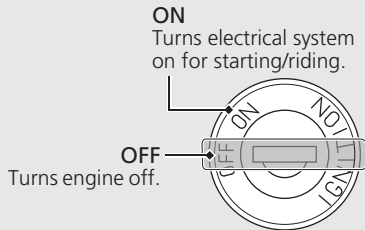

Steering Lock

Lock the steering when parking to help prevent theft.

A U-shaped wheel lock or similar device is also recommended.

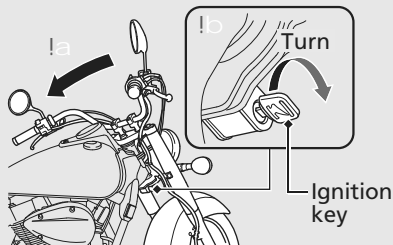

Locking

- Turn the handlebars all the way to the left.
- Insert the key in the steering lock and turn it 180 degrees clockwise.
- Remove the key.

Unlocking

Insert the key and turn it 180 degrees counterclockwise.

Starting the Engine

Start your engine using the following procedure, regardless of whether the engine is cold or warm.

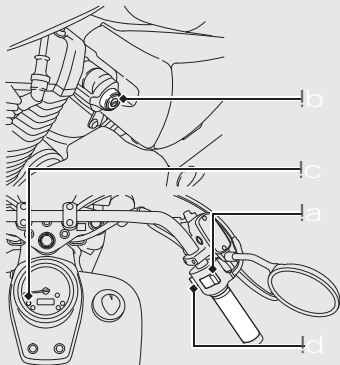

NOTICE

- If the engine does not start within 5 seconds, turn the ignition off and wait 10 seconds before trying to start the engine again to recover battery voltage.
- Extended fast idling and revving the engine can damage the engine, and the exhaust system.
- Snapping the throttle or fast idling for more than about 5 minutes may cause exhaust pipe discoloration.

- !a Make sure the engine stop switch is in the  (Run) position.
- !b Turn the ignition switch to the ON position.
- !c Shift the transmission to Neutral (**N** indicator comes on). Alternatively, pull in the clutch lever to start your motorcycle with the transmission in gear so long as the side stand is raised.
- !d Press the start button with the throttle completely closed.

If the engine does not start:

- a Open the throttle fully and press the start button for 5 seconds.
- b Repeat the normal starting procedure.
- c If the engine starts, open the throttle slightly if idling is unstable.
- d If the engine does not start, wait 10 seconds before trying steps a & b again.

| If Engine Will Not Start (P77)

Shifting Gears

Your motorcycle transmission has 5 forward gears in a one-down, four-up shift pattern.

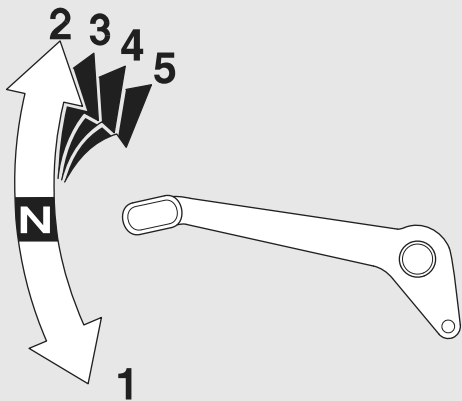

If you put the motorcycle in gear with the side stand down, the engine will shut off.

Recommended Shift Points

Shifting Up

From 1st to 2nd	12 mph (20 km/h)
From 2nd to 3rd	19 mph (30 km/h)
From 3rd to 4th	25 mph (40 km/h)
From 4th to 5th	31 mph (50 km/h)

Shifting Down

From 5th to 4th	28 mph (45 km/h)
From 4th to 3rd	22 mph (35 km/h)

NOTICE

Improper shifting can damage the engine, transmission, and drive train. Also, coasting or towing the motorcycle for long distances with the engine off can damage the transmission.

Refueling

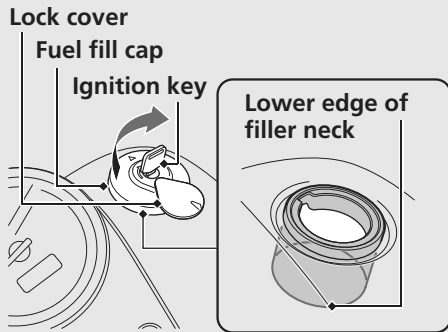

Do not fill with fuel above the lower edge of the filler neck.

Fuel type: Unleaded gasoline only

Recommended fuel octane number:

Pump Octane Number (PON) 86 or higher.

Tank capacity: 3.70 US gal (14.0 liters)

Refueling and Fuel Guidelines (P13)

Opening the Fuel Fill Cap

Open the lock cover, insert the ignition key, and turn it clockwise to open the fuel fill cap.

Closing the Fuel Fill Cap

- After refueling, align the fuel cap latch with the slot in the filler neck. Push the fuel fill cap into the filler neck until it snaps closed and locks.
- Remove the ignition key and close the lock cover.
 - The ignition key cannot be removed if the fuel fill cap is not locked.

3 WARNING

Gasoline is highly flammable and explosive. You can be burned or seriously injured when handling fuel.

- Stop the engine, and keep heat, sparks, and flame away.
- Handle fuel only outdoors.
- Wipe up spills immediately.

Storage Equipment

Helmet holder is located on the left side below the seat.

Helmet holder

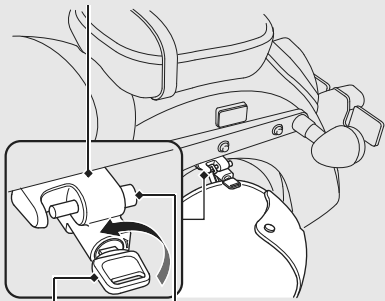

Ignition key Pin

- ▶ Use the helmet holder only when parked.
- ▶ Insert the ignition key and turn it counterclockwise to unlock. Hang your helmet on the holder pin and push it in to lock. Remove the key.

3 WARNING

Riding with a helmet attached to the holder can interfere with the rear wheel or suspension and could cause a crash in which you can be seriously hurt or killed.

Use the helmet holder only while parked. Do not ride with a helmet secured by the holder.

Space to store a document bag is located under the seat.

Document bag

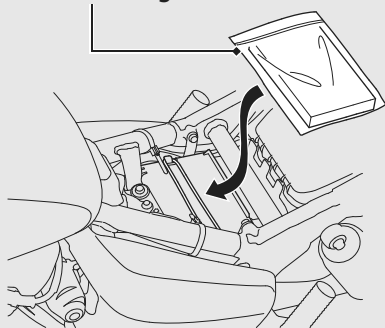

Removing the Seat (P48)

The tool kit is in the compartment box behind the left side cover.

(VT750C)

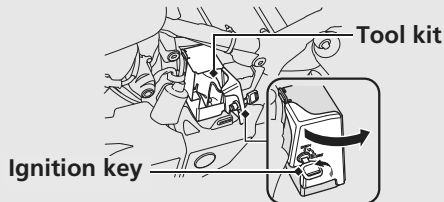

▶ Insert the ignition key and turn it counterclockwise to unlock.

(VT750CS)

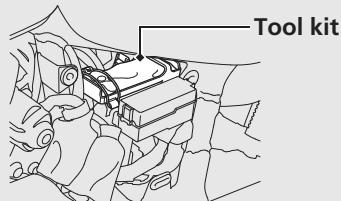

Removing the Side Cover (P49)

Maintenance

Please read “Importance of Maintenance” and “Maintenance Fundamentals” carefully before attempting any maintenance. Refer to “Specifications” for service data.

An optional larger tool kit may be available. Check with your Honda dealer’s parts department.

Importance of Maintenance	P. 31	Final Drive Oil	P. 69
Maintenance Schedule	P. 33	Air Cleaner	P. 71
Maintenance Fundamentals	P. 36	Crankcase Breather	P. 72
Removing & Installing Body Components ...	P. 48	Throttle	P. 73
Seat	P. 48	Other Adjustments	P. 74
Side Cover	P. 49	Rear Suspension	P. 74
Battery	P. 50	Headlight Aim	P. 75
Spark Plug	P. 51	Brake Light Switch	P. 75
Engine Oil	P. 53		
Coolant	P. 57		
Brakes/Clutch	P. 59		
Side Stand	P. 68		

Importance of Maintenance

Importance of Maintenance

Keeping your motorcycle well-maintained is absolutely essential to your safety and to protect your investment, obtain maximum performance, avoid breakdowns, and reduce air pollution. Maintenance is the owner's responsibility. Be sure to inspect your motorcycle before each ride, and perform the periodic checks specified in the Maintenance Schedule. ➔ P. 33

3 WARNING

Improperly maintaining your motorcycle or failing to correct a problem before you ride can cause a crash in which you can be seriously hurt or killed.

Always follow the inspection and maintenance recommendations and schedules in this owner's manual.

For information about the exhaust emission and noise emission requirements of the U.S. Environmental Protection Agency (EPA), the California Air Resources Board (CARB), and Environment Canada (EC). ➔ P. 108

USA

Maintenance, replacement or repair of the emission control devices and systems may be performed by any motorcycle repair establishment or individual using parts that are "certified" to EPA standards.

Maintenance Safety

Always read the maintenance instructions before you begin each task, and make sure that you have the tools, parts, and skills required. We cannot warn you of every conceivable hazard that can arise in performing maintenance. Only you can decide whether or not you should perform a given task.

Follow these guidelines when performing maintenance.

- Stop the engine and remove the key.
- Park your motorcycle on a firm, level surface using the side stand or a maintenance stand to provide support.
- Allow the engine, muffler, brakes, and other high-temperature parts to cool before servicing as you can get burned.
- Run the engine only when instructed, and do so in a well-ventilated area.

Maintenance Schedule







The maintenance schedule specifies the maintenance requirements necessary to ensure safe, dependable performance, and proper emission control.

Maintenance work should be performed in accordance with Honda's standards and specifications by properly trained and equipped technicians. Your dealer meets all of these requirements. Keep an accurate record of maintenance to help ensure that your motorcycle is properly maintained. Make sure that whomever performs the maintenance completes this record.

All scheduled maintenance is considered a normal owner operating cost and will be charged for by your dealer. Retain all receipts. If you sell the motorcycle, these receipts should be transferred with the motorcycle to the new owner.

Honda recommends that your dealer should road test your motorcycle after each periodic maintenance is carried out.

Maintenance Schedule

Items		Frequency	Odometer Reading*1							Refer to page	
			x 1,000 mi	0.6	4	8	12	16	20		24
			x 1,000 km	1.0	6.4	12.8	19.2	25.6	32.0		38.4
Emission-related Items	Fuel Line					I		I		I	-
	Throttle Operation					I		I		I	73
	Air Cleaner*2						R			R	71
	Crankcase Breather*3				C	C	C	C	C	C	72
	Spark Plug				I	R	I	R	I	R	51
	Valve Clearance			I		I		I		I	-
	Engine Oil		Initial = 600 mi (1,000 km) or 1 month: R Regular = Every 8,000 mi (12,800 km) or 12 months: R							53	
	Engine Oil Filter			R		R		R		R	55
	Engine Idle Speed			I	I	I	I	I	I	I	-
	Radiator Coolant*4					I		I		R	57
	Cooling System					I		I		I	-
	Secondary Air Supply System					I		I		I	-
	Evaporative Emission Control System*5						I			I	-

Maintenance Level

 : Intermediate. We recommend service by your Honda dealer, unless you have the necessary tools and are mechanically skilled. Procedures are provided in an official Honda Service Manual (📖 P. 115).

 : Technical. In the interest of safety, have your motorcycle serviced by your dealer.

Items		Frequency	Odometer Reading*1							Refer to page	
			x 1,000 mi	0.6	4	8	12	16	20		24
			x 1,000 km	1.0	6.4	12.8	19.2	25.6	32.0		38.4
Non-Emission-Related Items	Final Drive Oil				I		I		R	69	
	Brake Fluid*4			I	I	R	I	I	R	59	
	Brake Shoe/Pad Wear	VT750C		I	I	I	I	I	I	60, 64	
	Brake Pad Wear	VT750CS		I	I	I	I	I	I	60	
	Brake System		I		I		I		I	59	
	Brake Light Switch	🔧			I		I		I	75	
	Headlight Aim	🔧			I		I		I	75	
	Clutch System		I	I	I	I	I	I	I	65	
	Side Stand				I		I		I	68	
	Suspension	🔧			I		I		I	74	
	Nuts, Bolts, Fasteners	🔧		I		I		I		I	-
	Wheels/Tires	🔧		I	I	I	I	I	I	I	44
	Steering Head Bearings	🔧		I		I		I		I	-

Maintenance Legend

I : Inspect (clean, adjust, lubricate, or replace, if necessary)

C : Clean

R : Replace

Notes:

*1 : At higher odometer readings, repeat at the frequency interval established here.

*2 : Service more frequently when riding in unusually wet or dusty areas.

*3 : Service more frequently if the motorcycle is ridden often at full throttle or in the rain.

*4 : Replace every 2 years, or at indicated odometer intervals, whichever comes first. Replacement requires mechanical skill.

*5 : 50 STATE (meets California)

Pre-ride Inspection

To ensure safety, it is your responsibility to perform a pre-ride inspection and make sure that any problem you find is corrected. A pre-ride inspection is a must, not only for safety, but because having a breakdown, or even a flat tire, can be a major inconvenience.

Check the following items before you get on your motorcycle:

- Fuel level-Fill fuel tank when necessary. ➤ P. 27
- Throttle-Check for smooth opening and full closing in all steering positions. ➤ P. 73
- Engine oil level-Add engine oil if necessary. Check for leaks. ➤ P. 53
- Coolant level-Add coolant if required. Check for leaks. ➤ P. 57

- Brakes (VT750C)-Check operation; Front: check brake fluid level (➤ P. 59) and pads wear. ➤ P. 60
Rear: check shoes wear (➤ P. 64) and freeplay (➤ P. 61), adjust if necessary. ➤ P. 62
- Brakes (VT750CS)-Check operation; Front and Rear: check brake fluid level (➤ P. 59) and pads wear. ➤ P. 60
- Lights and horn-Check that lights, indicators and horn function properly.
- Engine stop switch-check for proper function. ➤ P. 22
- Clutch-Check operation; Adjust freeplay if necessary. ➤ P. 65
- Side stand ignition cut-off system-check for proper function. ➤ P. 68
- Wheels and tires-Check condition, air pressure and adjust if necessary. ➤ P. 44

Periodic Checks

You should also perform other periodic maintenance checks at least once a month regardless of how often you ride, or more often if you ride frequently.

Also, check the odometer reading against the Maintenance Schedule and perform all maintenance that is due. ➤ P. 33

Tires and wheels	Check the air pressure (➤ P. 44), examine tread for wear and damage (➤ P. 44), and check the wheels for damage.
Fluid levels	Check the engine oil level (➤ P. 53), engine coolant level (➤ P. 57), and brake fluid level (➤ P. 59), final drive oil level (➤ P. 69).
Lights	Check that the headlight, brake light, taillight, turn signals and license plate light are working properly.
Controls	Check the freeplay of the clutch lever (➤ P. 65), throttle grip (➤ P. 73), and rear brake pedal (➤ P. 61).
Fuses	Check that you have a full supply of spare fuses.
Nuts & bolts	Check the major nuts and bolts, and tighten as needed.

Replacing Parts

Always use Honda Genuine Parts or their equivalents to ensure reliability and safety. When ordering colored components, specify the model name, color, and code mentioned on the color label. The color label is attached to the frame behind the left side cover.

➤ P. 49

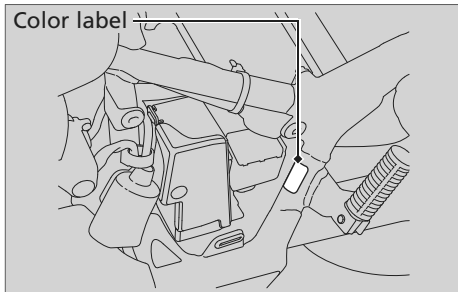

3 WARNING

Installing non-Honda parts may make your motorcycle unsafe and cause a crash in which you can be seriously hurt or killed.

Always use Honda Genuine Parts or equivalents that have been designed and approved for your motorcycle.

Battery

Your motorcycle has a maintenance-free type battery. You do not have to check the battery electrolyte level or add distilled water. Clean the battery terminals if they become dirty or corroded.

Do not remove the battery cap seals. There is no need to remove the cap when charging.

What to do in an emergency

If any of the following occur, immediately see your doctor.

- Electrolyte splashes into your eyes:
 - ▶ Wash your eyes repeatedly with cool water for at least 15 minutes. Using water under pressure can damage your eyes.
- Electrolyte splashes onto your skin:
 - ▶ Remove affected clothing and wash your skin thoroughly using water.

- Electrolyte splashes into your mouth:
 - ▶ Rinse mouth thoroughly with water, and do not swallow.

3 WARNING

The battery gives off explosive hydrogen gas during normal operation. A spark or flame can cause the battery to explode with enough force to kill or seriously hurt you.

Wear protective clothing and a face shield, or have a skilled mechanic do the battery servicing.

WARNING: Battery posts, terminals, and related accessories contain lead and lead compounds.

Wash your hands after handling.

Cleaning the Battery Terminals

1. Remove the battery. ➔ P. 50
2. If the terminals are starting to corrode and are coated with a white substance, wash with warm water and wipe clean.
3. If the terminals are heavily corroded, clean the terminals with a wire brush or sandpaper. Wear safety glasses.

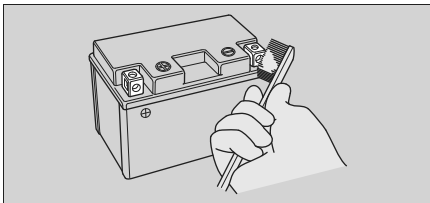

4. After cleaning, reinstall the battery.

The battery has a limited life span. Consult your dealer about when you should replace the battery. Always replace the battery with another maintenance-free battery of the same type.

Charging

If you use electrical accessories that drain the battery or you do not ride frequently, we recommend that you charge the battery every 30 days using a charger designed specifically for your Honda, which can be purchased from your dealer. Read the information that came with your battery charger and follow the instructions on the battery. Avoid using an automobile-type battery charger, as these can overheat a motorcycle battery and cause permanent damage.

Make sure the ignition switch is in the OFF position before charging the battery.

NOTICE

Improper charging can damage the battery. If you can't charge the battery or it appears unable to hold a charge, contact your dealer.

NOTICE

Jump starting using an automobile battery can damage your motorcycle's electrical system and is not recommended. Bump starting is also not recommended.

NOTICE

Installing non-Honda electrical accessories can overload the electrical system, discharging the battery and possibly damaging the system.

Fuses

Fuses protect the electrical circuits on your motorcycle. If something electrical on your motorcycle stops working, check for and replace any blown fuses. ➤ P. 95

Inspecting and Replacing Fuses

Turn off the ignition switch to remove and inspect fuses. If a fuse is blown, replace with a fuse of the same rating. For fuse ratings, see "Specifications." ➤ P. 122

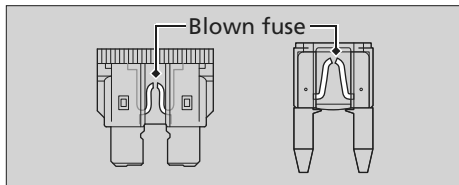
**NOTICE**

Replacing a fuse with one that has a higher rating greatly increases the chance of damage to the electrical system.

If a fuse fails repeatedly, you likely have an electrical fault. Have your motorcycle inspected by your dealer.

Engine Oil

Engine oil consumption varies and oil quality deteriorates according to riding conditions and time elapsed.

Check the engine oil level regularly, and add the recommended engine oil if necessary. Dirty oil or old oil should be changed as soon as possible.

Selecting the Engine Oil

For recommended engine oil, see “Specifications.” ➤ P. 121

If you use non-Honda engine oil, check the label to make sure that the oil satisfies all of the following standards:

- JASO T 903 standard*1: MA
- SAE standard*2: 10W-30
- API classification*3: SG or higher

- *1. The JASO T 903 standard is an index for engine oils for 4-stroke motorcycle engines. There are two classes: MA and MB. For example, the following label shows the MA classification.

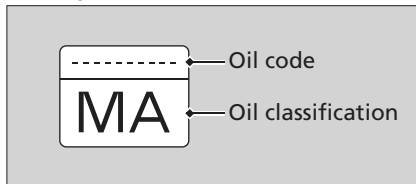

- *2. The SAE standard grades oils by their viscosity.
*3. The API classification specifies the quality and performance rating of engine oils. Use SG or higher oils, excluding oils marked as “Energy Conserving” or “Resource Conserving” on the circular API service symbol.

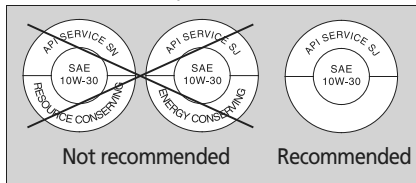

Brake Fluid

Do not add or replace brake fluid, except in an emergency. Use only fresh brake fluid from a sealed container. If you do add fluid, have the brake system serviced by your dealer as soon as possible.

NOTICE

Brake fluid can damage plastic and painted surfaces. Wipe up spills immediately and wash thoroughly.

Recommended brake fluid:

Honda DOT 4 Brake Fluid or equivalent

3 WARNING

Clean filler cap before removing. Use only DOT 4 fluid from a sealed container.

Final Drive Oil

Recommended final drive oil:

Hypoid gear oil SAE 80

Recommended Coolant

Pro Honda HP coolant is a pre-mixed solution of antifreeze and distilled water.

Concentration:

50 % antifreeze and 50 % distilled water

A concentration of antifreeze below 40 % will not provide proper corrosion and cold temperature protection. A concentration of up to 60 % will provide better protection in colder climates.

NOTICE

Using coolant not specified for aluminum engines or using ordinary tap water can cause corrosion.

Air Cleaner

This motorcycle is equipped with a viscous type air cleaner element which cannot be cleaned with compressed air or otherwise without degrading its performance.

If the filter becomes dirty, replace it with a new one.

Crankcase Breather

Service more frequently when riding in rain, at full throttle, or after the motorcycle is washed or overturned. Service if the deposit level can be seen in the transparent section of the drain tube.

If the drain tube overflows, the air filter may become contaminated with engine oil causing poor engine performance.

Tires (Inspecting/Replacing)

Checking the Air Pressure

Visually inspect your tires and use an air pressure gauge to measure the air pressure at least once a month or any time you think the tires look low. Always check air pressure when your tires are cold.

Inspecting for Damage

Inspect the tires for cuts, slits, or cracks that exposes fabric or cords, or nails or other foreign objects embedded in the side of the tire or the tread. Also inspect for bumps or bulges in the side walls of the tires.

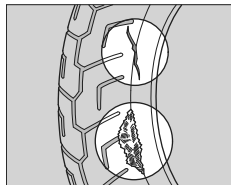

Inspecting for Abnormal Wear

Inspect the tires for signs of abnormal wear on the contact surface.

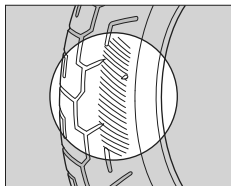

Inspecting Tread Depth

Inspect the tread wear indicators. If they become visible, replace the tires immediately. For your safety, you should replace the tires when the minimum tread depth is reached.

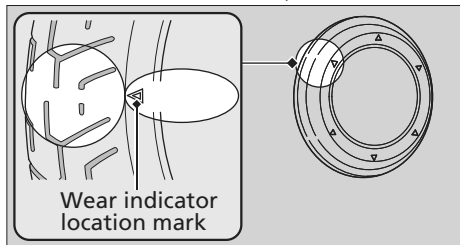

3 WARNING

Riding on tires that are excessively worn or improperly inflated can cause a crash in which you can be seriously hurt or killed.

Follow all instructions in this owner's manual regarding tire inflation and maintenance.

Maintenance Fundamentals

Have your tires replaced by your dealer. For recommended tires, air pressure and minimum tread depth, see “Specifications.”

➤ P. 121

Follow these guidelines whenever you replace tires.

- Use the recommended tires or equivalents of the same size, construction, speed rating, and load range.
- Have the wheel balanced with Honda Genuine balance weights or equivalent after the tire is installed.
- Remember to replace the inner tube whenever you replace a tire. The old tube will probably be stretched, and it could fail if installed in a new tire.

3 WARNING

Installing improper tires on your motorcycle can adversely affect handling and stability, and can cause a crash in which you can be seriously hurt or killed.

Always use the size and type of tires recommended in this owner's manual.

Tire Service Life

The service life of your tires is dependent on many factors, including, but not limited to, riding habits, road conditions, vehicle loading, tire air pressure, maintenance history, speed, and environmental conditions (even when the tires are not in use).

In addition to your regular inspections and maintenance, it is recommended that you have annual inspections performed once the tires reach 5 years old. It is also recommended that all tires be removed from service after 10 years from the date of manufacture, regardless of their condition or state of wear.

The last four digits of the TIN (tire identification number) indicate the date of manufacture.

Tire Identification Number (TIN)

The tire identification number (TIN) is a group of numbers and letters located on the sidewall of the tire.

a b c

DOT XXXX XXXX 22 09

DOT: This indicates that the tire meets all requirements of the U.S. Department of Transportation.

- a XXXX: Factory code
- b XXXX: Tire type code
- c 22 09: Date of manufacture (week & year).
Example: week 22 in year 09.

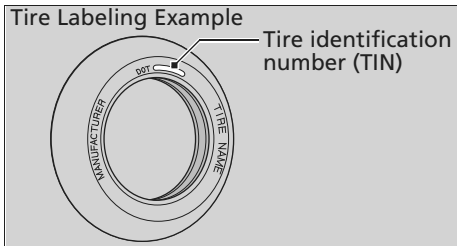

Seat

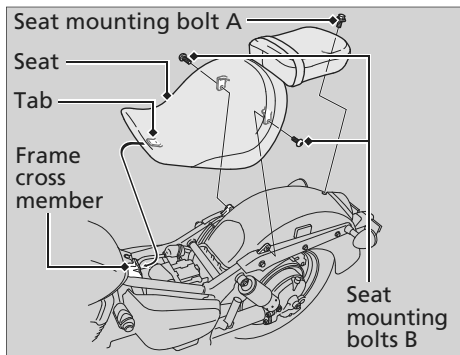

Removal

1. Remove the mounting bolt A and bolts B.
2. Pull the seat back and up.

Installation

1. Insert the tab into the frame cross member.
2. Tighten the seat mounting bolts securely.

Side Cover

(VT750C)

The right side cover must be removed for the fuse maintenance.

The left side cover must be removed to access the storage compartment and check the color label.

(VT750CS)

The left side cover must be removed for the fuse maintenance and to access the storage compartment and check the color label.

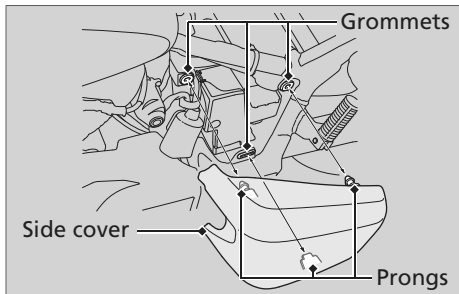

The right and left side covers can be removed in the same way.

Removal

1. Grasp the side cover.
2. Remove the prongs from the grommets.
3. Remove the side cover.

Installation

Install the parts in the reverse order of removal.

Battery

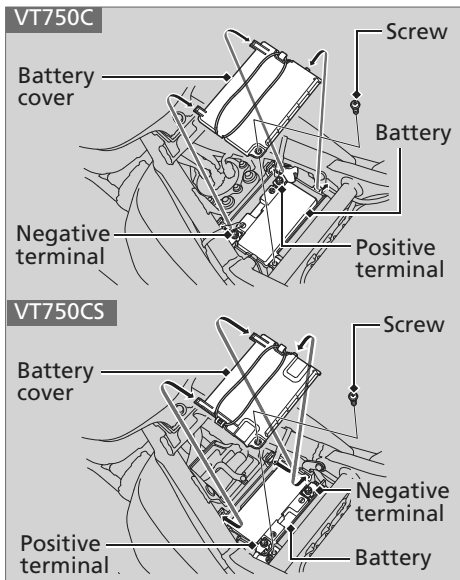

Removal

Make sure the ignition switch is off.

1. Remove the seat. ► P. 48
2. Remove the battery cover by removing the screw.
3. Disconnect the negative \ominus terminal from the battery.
4. Disconnect the positive \oplus terminal from the battery.
5. Remove the battery taking care not to drop the terminal nuts.

Installation

Install the parts in the reverse order of removal.

Always connect the positive \oplus terminal first.

Make sure that bolts and nuts are tight.

Reset the clock to the correct time after the battery is reconnected. ► P. 19

For proper handling of the battery, see

“Maintenance Fundamentals.” ► P. 39

Battery Goes Dead ► P. 91

Checking Spark Plug

For the recommended spark plug, see “Specifications.” ➤ P. 121

Use only the recommended type of spark plug in the recommended heat range.

NOTICE

Using spark plugs an improper heat range can cause engine damage.

1. Disconnect the spark plug cap.
2. Clean any dirt from around the spark plug base.
3. Remove the spark plug using the spark plug wrench provided in the tool kit.

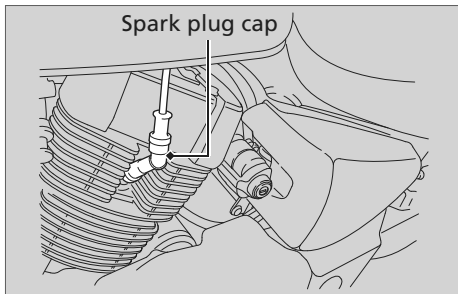

4. Inspect the electrodes and center porcelain for deposits, erosion or carbon fouling.
 - ▶ If the erosion or deposit is heavy, replace the plug.
 - ▶ Clean a carbon or wet-fouled plug with a plug cleaner, otherwise use a wire brush.

Spark Plug ► Checking Spark Plug

5. Check the spark plug gap using a wire-type feeler gauge.
 - If adjustment is necessary, bend the side electrode carefully.

The gap should be:

0.031 to 0.035 in (0.80 to 0.90 mm)

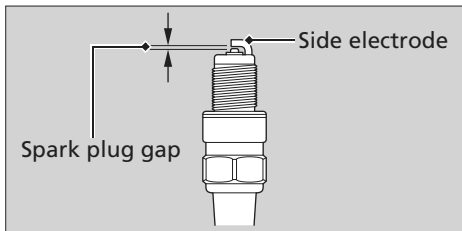

6. Make sure the plug washer is in good condition.
7. With the plug washer attached, thread the spark plug in by hand to prevent cross-threading.

8. Tighten the spark plug:
 - If the old plug is good:
 - 1/8 turn after it seats
 - If installing a new plug, tighten it twice to prevent loosening:
 - a) First, tighten the plug:
 - NGK: 3/4 turn after it seats.
 - DENSO: 1/2 turn after it seats.
 - b) Then loosen the plug.
 - c) Next, tighten the plug again:
 - 1/8 turn after it seats.

NOTICE

Improperly tightened spark plugs can damage the engine. If a plug is too loose, a piston may be damaged. If a plug is too tight, the threads may be damaged.

9. Reinstall the spark plug cap. Take care avoid pinching any cables or wires.

Checking the Engine Oil

1. If the engine is cold, idle the engine for 3 to 5 minutes.
2. Turn the ignition switch off, and wait for 2 to 3 minutes.
3. Remove the oil fill cap/dipstick and wipe it clean.
4. Place your motorcycle in an upright position on a firm, level surface.
5. Insert the oil fill cap/dipstick until it seats, but don't screw it in.
Check that the oil level is between the upper and lower level marks in the oil fill cap/dipstick.
6. Securely install the oil fill cap/dipstick.

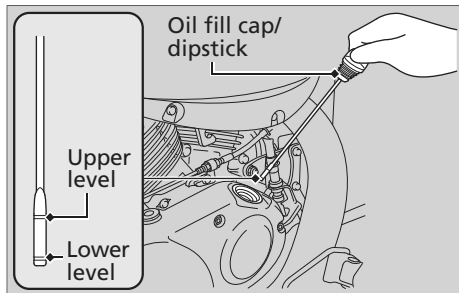

Adding Engine Oil

If the engine oil is below or near the lower level mark, add the recommended engine oil.

► P. 42

1. Remove the oil fill cap/dipstick. Add the recommended oil until it reaches the upper level mark.
 - Place your motorcycle in an upright position on a firm, level surface when checking the oil level.
 - Do not overfill above the upper level mark.
 - Make sure no foreign objects enter the oil filler opening.
 - Wipe up any spills immediately.

2. Securely reinstall the oil fill cap/dipstick.

NOTICE

Overfilling with oil or operating with insufficient oil can cause damage to your engine. Do not mix different brands and grades of oil. They may affect lubrication and clutch operation.

For the recommended oil and oil selection guidelines, see "Maintenance Fundamentals." ► P. 42

Changing Engine Oil & Filter

Changing the oil and filter requires special tools. We recommend that you have your motorcycle serviced by your dealer.

Use a new Honda Genuine oil filter or equivalent specified for your model.

NOTICE

Using the wrong oil filter can result in serious damage to the engine.

1. If the engine is cold, idle the engine for 3 to 5 minutes.
2. Turn the ignition switch off, and wait for 2 to 3 minutes.
3. Park on a firm, level surface and lower the side stand.
4. Place a drain pan under the drain bolt.
5. Remove the oil fill cap/dipstick, drain bolt, and sealing washer to drain the oil.

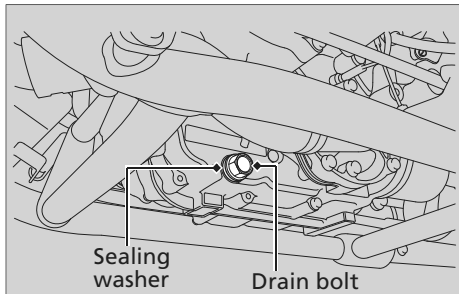

- Remove the oil filter with a filter wrench and let the remaining oil drain out. Make sure the prior seal is not stuck to the engine.

► Discard the oil and oil filter at an approved recycling center.

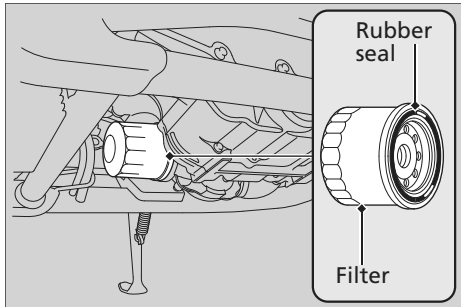

- Apply a thin coat of engine oil to the rubber seal of a new oil filter.
- Install the new oil filter and tighten.

Torque: 19 lbf·ft (26 N·m, 2.7 kgf·m).

- Install a new sealing washer onto the drain bolt. Tighten the drain bolt.

Torque: 21 lbf·ft (29 N·m, 3.0 kgf·m).

- Fill the crankcase with the recommended oil (► P. 42) and install the oil fill cap/dipstick.

Required oil

When changing oil & engine oil filter:

2.7 US qt (2.6 liters)

When changing oil only:

2.6 US qt (2.5 liters)

- Check the oil level. ► P. 53
- Check that there are no oil leaks.

Checking the Coolant

1. Place your motorcycle on a firm, level surface.
2. Hold your motorcycle in an upright position.
3. Check that the coolant level is between the UPPER and LOWER level marks in the reserve tank.

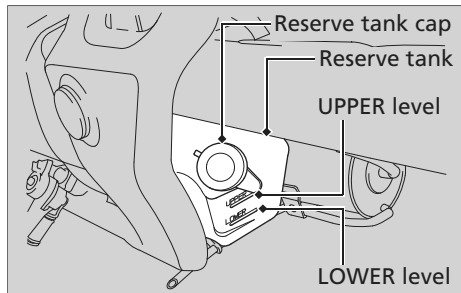

If the coolant level is dropping noticeably or the reserve tank is empty, you likely have a serious leak. Have your motorcycle inspected by your dealer.

Adding Coolant

If the coolant level is below the LOWER level mark, add recommended coolant (▶ P. 43) until the level reaches the UPPER level mark. Add fluid only from the reserve tank cap and do not remove the radiator cap.

1. Remove the reserve tank cap and add fluid while monitoring the coolant level.
 - ▶ Do not overfill above the UPPER level mark.
 - ▶ Make sure no foreign objects enter the reserve tank opening.
2. Securely reinstall the cap.

3 WARNING

Removing the radiator cap while the engine is hot can cause the coolant to spray out, potentially scalding you.

Always let the engine and radiator cool down before removing the radiator cap.

Changing Coolant

Have your dealer change the coolant unless you have the proper tools and are mechanically qualified.

Checking Brake Fluid

1. Place your motorcycle in an upright position on a firm, level surface.
2. **Front** Check that the brake fluid reservoir is horizontal and that the fluid level is above the LOWER level mark.
3. **Rear (VT750CS)** Check that the brake fluid reservoir is horizontal and that the level is between the LOWER level and UPPER level marks.

If the brake fluid level in either reservoir is below the LOWER level mark or the brake lever and pedal freeplay becomes excessive, inspect the brake pads for wear. If the brake pads are not worn, you most likely have a leak. Have your motorcycle inspected by your dealer.

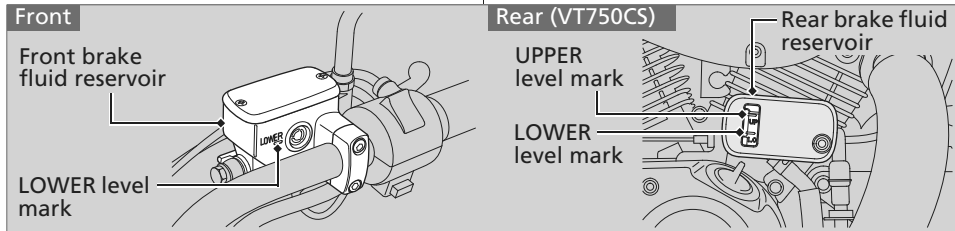

Inspecting the Brake Pads

Check the condition of the brake pad wear indicators.

Front The pads need to be replaced if a brake pad is worn to the indicator.

Rear (VT750CS) The pads need to be replaced if a brake pad is worn to the bottom of the indicator.

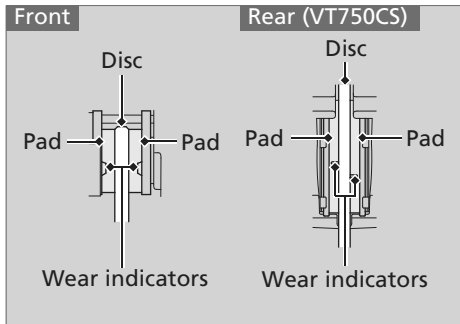

1. **Front** Inspect the brake pads from the bottom of the brake caliper.
2. **Rear (VT750CS)** Inspect the brake pads from the rear right of the motorcycle.

If necessary have the pads replaced by your dealer.

Always replace both left and right brake pads at the same time.

Inspecting the Rear Brake Pedal Freeplay (VT750C only)

Pedal Height Adjustment

The stopper bolt is provided to allow adjustment of the pedal height.

1. Loosen the lock nut and turn the stopper bolt.
2. Tighten the lock nut.

Inspection

1. Place your motorcycle on a firm, level surface.
2. Measure the distance of the rear brake pedal before the starts to take hold.

Freeplay at the tip of the brake pedal: 13/16 to 1 3/16 in (20 to 30 mm)

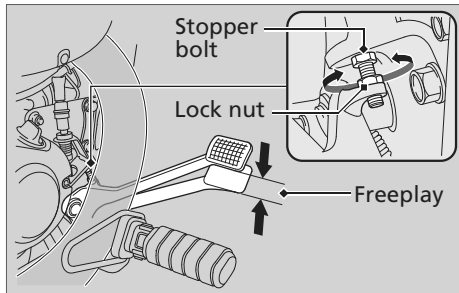

Make sure the brake rod, brake arm, spring and fastener are in good condition.

Adjusting Rear Brake Pedal Freeplay (VT750C only)

Make sure the cut-out on the adjusting nut is seated on the brake arm pin when adjusting the freeplay.

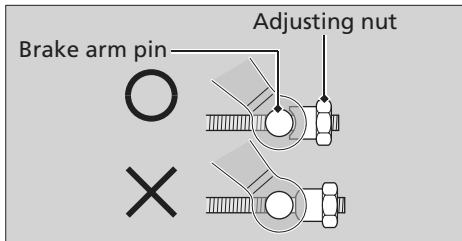

If proper adjustment cannot be obtained by this method, see your dealer.

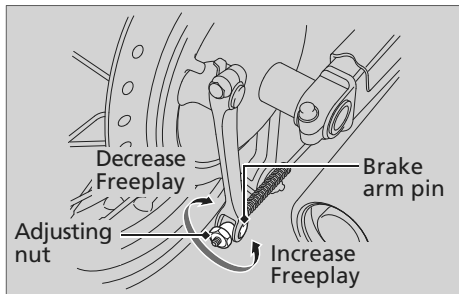

1. Adjust by turning the rear brake adjusting nut a half-turn at a time.
2. Apply the brake several times and check for free wheel rotation after the brake pedal is released.

3. Push the brake arm to confirm that there is a gap between the rear brake adjusting nut and brake arm pin.

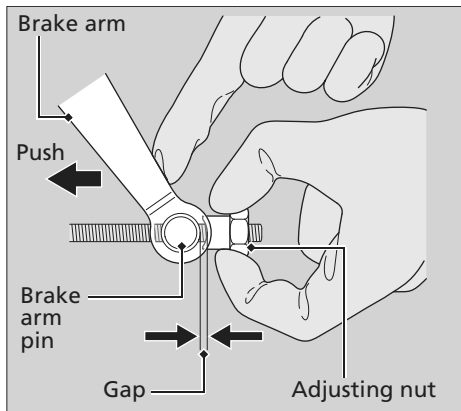

After adjustment, confirm the freeplay of the brake pedal.

NOTICE

Do not turn the adjuster beyond its natural limits.

Inspecting the Brake Shoe Wear (VT750C only)

The rear brake is equipped with a brake wear indicator.

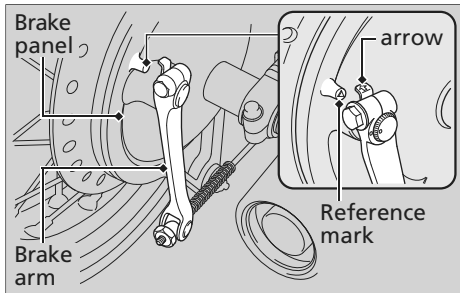

When the brake is applied, an arrow attached to the brake arm moves toward a reference mark on the brake panel. If the arrow aligns with the reference mark on full application of the brake, the brake shoes must be replaced.

See your dealer for this service.

When the brake service is necessary, see your dealer. Use only Honda Genuine Parts or its equivalent.

Checking the Clutch

Checking the Clutch Lever Freeplay

Check the clutch lever freeplay.

Freeplay at the clutch lever:

3/8 to 13/16 in (10 to 20 mm)

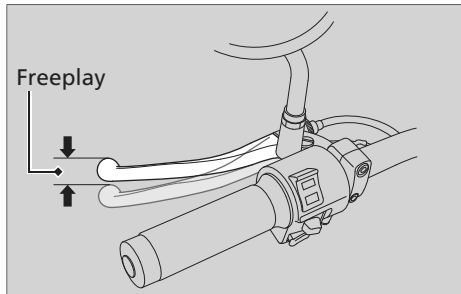

Check the clutch cable for kinks or signs of wear. If necessary have it replaced by your dealer.

Lubricate the clutch cable with a commercially available cable lubricant to prevent premature wear and corrosion.

NOTICE

Improper freeplay adjustment can cause premature clutch wear.

Adjusting the Clutch Lever Freeplay

Upper Adjustment

Attempt adjustment with the upper clutch cable adjuster first.

1. Loosen the upper lock nut.
2. Turn the upper clutch cable adjuster until the freeplay is $\frac{3}{8}$ to $\frac{13}{16}$ in (10 to 20 mm).
3. Tighten the upper lock nut and check the freeplay again.

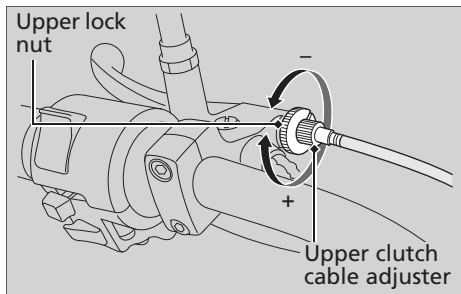

Lower Adjustment

If the upper clutch cable adjuster is threaded out near its limit, or the correct freeplay cannot be obtained, attempt adjustment with the lower adjusting nut.

1. Loosen the upper lock nut and turn the upper clutch cable adjuster all the way in (to provide maximum freeplay). Tighten the upper lock nut.
2. Loosen the lower lock nut.
3. Turn the lower adjusting nut until the clutch lever freeplay is $\frac{3}{8}$ to $\frac{13}{16}$ in (10 to 20 mm).
4. Tighten the lower lock nut and check the clutch lever freeplay.
5. Start the engine, pull the clutch lever in, and shift into gear. Make sure the engine does not stall and the motorcycle does not creep. Gradually release the clutch lever and open the throttle. Your motorcycle should move smoothly and accelerate gradually.

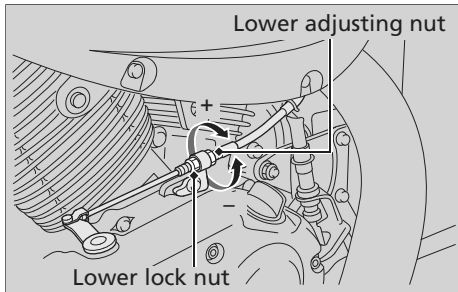

If proper adjustment cannot be obtained or the clutch does not work correctly, see your dealer.

Side Stand

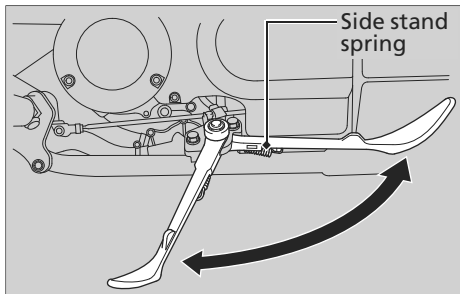

1. Check that the side stand operates smoothly. If the side stand is stiff or squeaky, clean the pivot area and lubricate the pivot bolt with clean grease.
2. Check the spring for damage or loss of tension.
3. Sit on the motorcycle, put the transmission in Neutral, and raise the side stand.
4. Start the engine, pull the clutch lever in, and shift the transmission into gear.
5. Lower the side stand all the way. The engine should stop as you lower the side stand. If the engine doesn't stop, have your motorcycle inspected by your dealer.

Checking the Final Drive Oil

1. Place your motorcycle on the side stand on a level surface.
2. Remove the oil fill hole cap and O-ring.
3. Check the oil level. It should be flush with the lower edge of the oil fill hole.

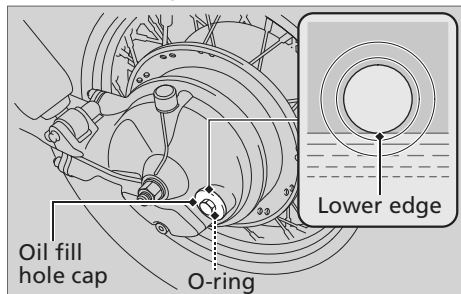

Adding Final Drive Oil

If the final drive oil level is low, check for oil leaks. Add the recommended final drive oil (➤ P. 43) until it reaches the lower edge of the opening.

1. Pour the final drive oil into the oil fill hole until it reaches the lower edge of the opening.
 - ▶ Do not over fill above the lower edge of oil fill hole.
 - ▶ Make sure no foreign objects enter the oil fill hole.
 - ▶ Wipe up any spills immediately.
2. Install a new O-ring onto the oil fill hole cap. Tighten the oil fill hole cap.

Torque: 9 lbf·ft (12 N·m, 1.2 kgf·m).

Changing Final Drive Oil

1. Place your motorcycle on the side stand on a level surface.
2. Place a drain pan under the drain bolt.
3. Remove the oil fill hole cap, O-ring, drain bolt, and sealing washer to drain the oil.

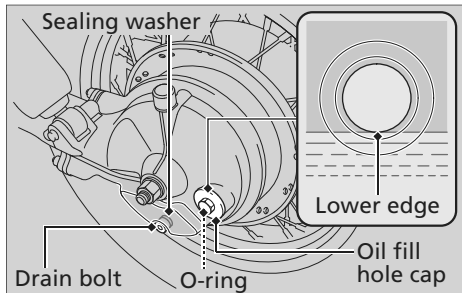

4. Install a new sealing washer onto the drain bolt. Tighten the drain bolt.

Torque: 9 lbf·ft (12 N·m, 1.2 kgf·m).

5. Fill the final gear with the recommended oil. [P. 43](#)

Required oil: 5.4 US oz (160 cm³)

6. Check the oil level. It should be flush with the lower edge of the oil fill hole.
7. Install a new O-ring onto the oil fill hole cap. Tighten the oil fill hole cap.

Torque: 9 lbf·ft (12 N·m, 1.2 kgf·m).

8. Check that there are no oil leaks.

Changing Air Cleaner Element

Use a new Honda Genuine air cleaner element or an equivalent specified for your motorcycle.

NOTICE

Using the wrong air cleaner element can result in serious damage to the engine.

1. Remove the air cleaner housing cover by removing the bolts.
2. Remove the air cleaner element.
3. Thoroughly clean the inside of the air cleaner housing.
4. Install the new air cleaner element.
5. Install the parts in the reverse order of removal.

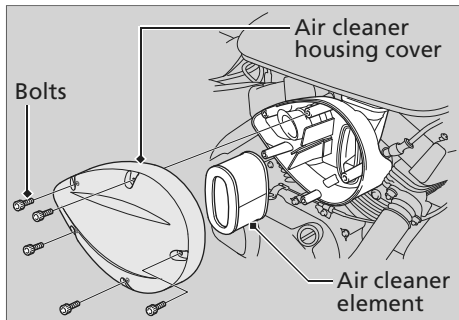

Crankcase Breather

1. Remove the crankcase breather tube and drain deposits.
2. Reinstall the crankcase breather tube.

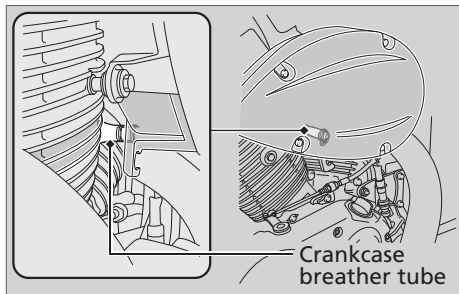

Checking the Throttle

With the engine off, check that the throttle rotates smoothly from fully closed to fully open in all steering positions and throttle freeplay is correct. If the throttle does not move smoothly, close automatically, or if the cable is damaged, have the motorcycle inspected by your dealer.

Freeplay at the throttle grip flange:
1/16 to 1/4 in (2 to 6 mm).

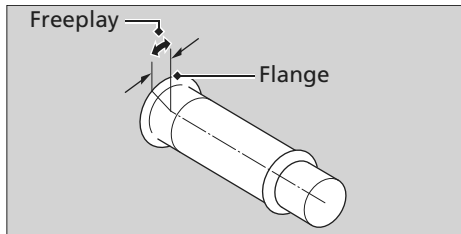

Adjusting the Throttle Freeplay

1. Slide the cable boot.
2. Loosen the lock nut.
3. Turn the adjuster until the freeplay is 1/16 to 1/4 in (2 to 6 mm).
4. Tighten the lock nut, return the cable boot, and inspect the throttle action again.

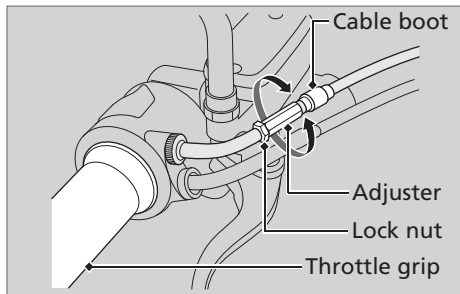

Adjusting the Rear Suspension

Adjusting the suspension requires a pin spanner. We recommend that you have your motorcycle serviced by your dealer.

Spring Preload

You can adjust the spring preload by the adjuster to suit the load or the road surface. Use the pin spanner to turn the adjuster. Position 1 is for a decrease spring preload (soft), or turn the position 3 to 5 increase spring preload (hard). The standard position is 2.

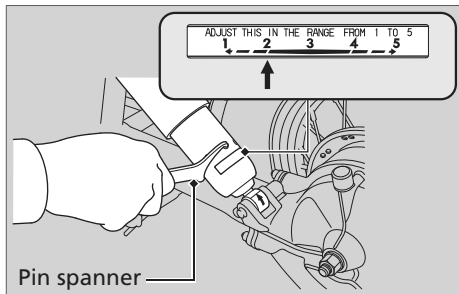

Attempting to adjust directly from 1 to 5 or 5 to 1 may damage the shock absorber.

NOTICE

Do not attempt to disassemble, service, or improperly dispose of the damper. See your dealer.
Adjust both left and right shock absorbers to the same spring preload.

Adjusting the Headlight Aim

You can adjust vertical aim of the headlight for proper alignment. To move the headlight case, loosen the bolts.

Tighten the bolts after adjustment.

Obey local laws and regulations.

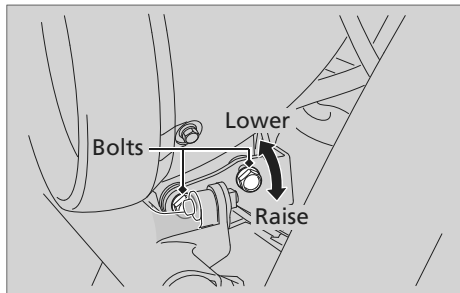

Adjusting the Brake Light Switch

Check the operation of the brake light switch. Hold the brake light switch and turn the adjusting nut in the direction A if the switch operates too late, or turn the nut in the direction B if the switch operates too soon.

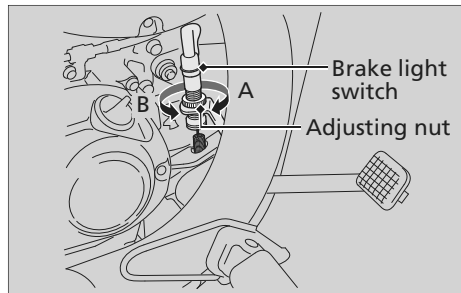

Troubleshooting

Engine Will Not StartP. 77

Overheating (High coolant temperature indicator is on)P. 78

Warning Indicators on or Flashing.....P. 79

Low Oil Pressure Indicator.....P. 79

PGM-FI (Programmed Fuel Injection)

Malfunction Indicator Lamp (MIL)P. 79

ABS (Anti-lock Brake System) Indicator
(VT750CS only).....P. 80

Tire PunctureP. 81

Tube Repair and ReplacementP. 81

Removing Wheels.....P. 81

Electrical Trouble P. 91

Battery Goes Dead P. 91

Burned-out Light Bulb P. 91

Blown Fuse P. 95

I Starter Motor Operates But Engine Does Not Start

Check the following items:

- Check the correct engine starting sequence ➤ [P. 24](#)
- Check that there is gasoline in the fuel tank
- Check if the PGM-FI malfunction indicator lamp (MIL) is on
 - ▶ If the indicator light is on, contact your dealer as soon as possible.

I Starter Motor Does Not Operate

Check the following items:

- Make sure engine stop switch is  (Run) position ➤ [P. 22](#)
- Check for a blown fuse ➤ [P. 95](#)
- Check for a loose battery connection or battery terminal corrosion ➤ [P. 40](#)
- Check the condition of the battery ➤ [P. 91](#)

If the problem continues, have your motorcycle inspected by your dealer.

Overheating (High coolant temperature indicator is on)

The engine is overheating when the following occurs:

- High coolant temperature indicator comes on
- Acceleration becomes sluggish

If this occurs, pull safely to the side of the road and perform the following procedure. Extended fast idling may cause the high coolant temperature indicator comes on.

NOTICE

Continuing to ride with an overheated engine can cause serious damage to the engine.

1. Stop the engine using the ignition switch, and then turn the ignition switch to the ON position.

2. Check that the radiator fan is operating, and then turn the ignition switch to the OFF position.

If the fan is not operating:

Suspect a fault. Do not start the engine. Transport your motorcycle to your dealer.

If the fan is operating:

Allow the engine to cool with the ignition switch in the OFF position.

3. After the engine has cooled, inspect the radiator hose and check if there is a leak.

[▶ P. 57](#)

If there is a leak:

Do not start the engine. Transport your motorcycle to your dealer.

4. Check the coolant level in the reserve tank, and add coolant as necessary.

[▶ P. 57](#)

5. If 1-4 check normal, you may continue riding, but closely monitor the temperature gauge.

Low Oil Pressure Indicator

If the low oil pressure indicator comes on, pull safely to the side of the road and stop the engine.

NOTICE

Continuing to ride with low oil pressure can cause serious damage to the engine.

1. Check the engine oil level, and add oil as necessary. [▶ P. 53](#)
2. Start the engine.
 - ▶ Only continue riding if the low oil pressure indicator goes off.

Rapid acceleration may momentarily cause the low oil pressure indicator to come on, especially if the oil is at or near the low level. If the low oil pressure indicator stays on when the oil level is at the proper level, stop the engine and contact your dealer.

If the engine oil level goes down rapidly, your motorcycle may have a leak or another serious problem. Have your motorcycle inspected by your dealer.

PGM-FI (Programmed Fuel Injection) Malfunction Indicator Lamp (MIL)

If the indicator comes on while riding, you may have a serious problem with the PGM-FI system. Reduce speed and have your motorcycle inspected by your dealer as soon as possible.

ABS (Anti-lock Brake System) Indicator (VT750CS only)

If the indicator operates in one of the following ways, you may have a serious problem with the brake system. Reduce your speed and have your motorcycle inspected by your dealer as soon as possible.

- Indicator comes on or starts flashing while riding
- Indicator does not come on when the ignition switch is in the on position
- Indicator does not go off at speeds above 6 mph (10 km/h)

If the ABS indicator stays on, your brakes will continue to work as a conventional system, but without the anti-locking function.

The ABS indicator may come on if you turn the rear wheel while your motorcycle is lifted off the ground. In this case, turn the ignition switch off and then on again. The ABS indicator will go off after your speed reaches 19 mph (30 km/h).

Tire Puncture

Repairing a puncture or removing a wheel requires special tools and technical expertise. We recommend you have this type of service performed by your dealer.

After an emergency repair, always have the tire inspected/replaced by your dealer.

Tube Repair and Replacement

If a tube is punctured or damaged, you should replace it as soon as possible. A tube that is repaired may not have the same reliability as a new one, and it may fail while you are riding.

If you need to make a temporary repair by patching a tube or using an aerosol sealant, ride cautiously at reduced speed and have the tube replaced before you ride again. Anytime a tube is replaced, the tire should be carefully inspected as described.

3 WARNING

Riding your motorcycle with a temporary tire or tube repair can be risky. If the temporary repair fails, you can crash and be seriously injured or killed.

If you must ride with a temporary tire or tube repair, ride slowly and carefully and do not exceed 30 mph (50 km/h) until the tire and tube are replaced.

Removing Wheels

Follow these procedures if you need to remove a wheel in order to repair a puncture.

(VT750CS only)

When removing and installing the wheel, be careful not to damage the wheel speed sensor and pulser ring.

Front Wheel

Removal

1. Park on a firm, level surface.
2. Remove the front axle bolt.

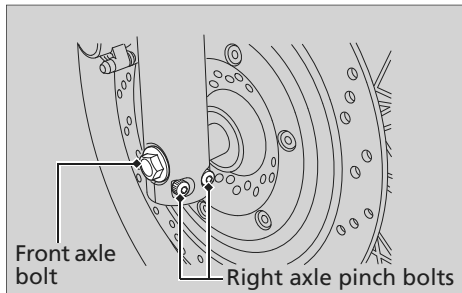

3. Loosen the right and left axle pinch bolts.

4. Support your motorcycle securely and raise the front wheel off the ground using a maintenance stand or a hoist.
5. Remove the front axle shaft, front wheel and side collars.
 - Avoid getting grease, oil, or dirt on the disc or pad surfaces.
 - Do not pull the brake lever while the wheel is off the motorcycle.

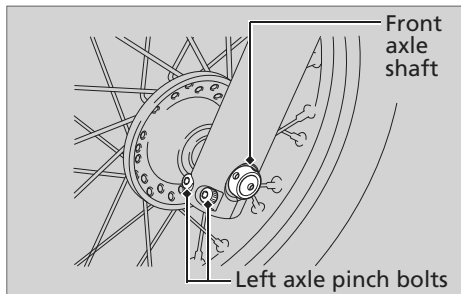

Installation

1. Attach the side collars to the wheel.
2. On the left side, place the wheel between the fork legs and insert the front axle shaft, through the left fork leg and wheel hub.
3. Align the index line of the front axle shaft with the recessed surface of the fork leg.

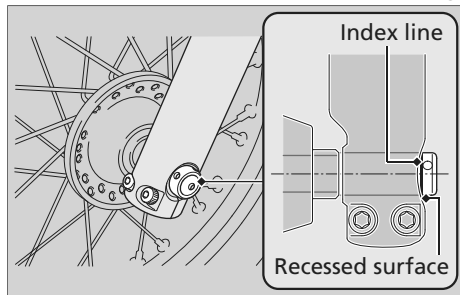

4. Tighten the left axle pinch bolts.

Torque: 16 lbf·ft (22 N·m, 2.2 kgf·m).

5. Tighten the axle bolt.

Torque: 44 lbf·ft (59 N·m, 6.0 kgf·m).

6. After installing the wheel, apply the brake lever several times, then check if the wheel rotates freely. Recheck the wheel if the brake drags or if the wheel does not rotate freely.

7. Check the clearances between each surface of the brake disc and the brake bracket (not the brake pads) are symmetrical.

► If the clearances are symmetrical, loosen the left axle pinch bolts and pull the left fork outward or push inward to adjust the clearance.

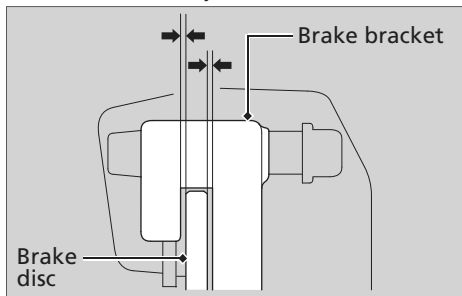

8. Tighten the right axle pinch bolts.

Torque: 16 lbf·ft (22 N·m, 2.2 kgf·m).

If a torque wrench was not used for installation, see your dealer as soon as possible to verify proper assembly.

► Rear Wheel

Muffler Removal

1. Park on a firm, level surface.
2. Remove the right footpeg by removing footpeg bolt A, B and footpeg nut.

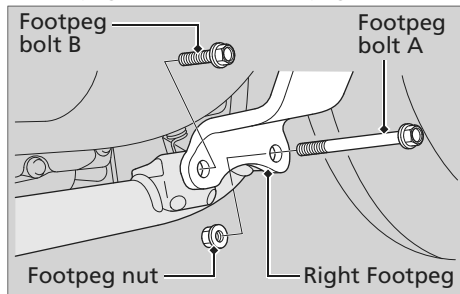

3. Remove the exhaust pipe joint nuts.

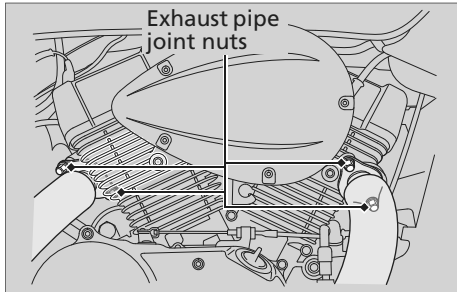

4. Remove the muffler bracket bolts and nuts, washers.
5. Remove the mufflers.

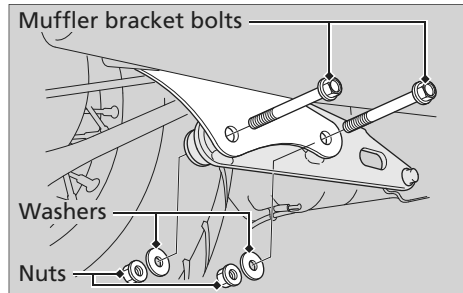

Wheel Removal (VT750C)

1. Park on a firm, level surface.
2. Support your motorcycle securely and raise the rear wheel off the ground using a maintenance stand or a hoist.
3. Remove the rear brake adjusting nut.
4. Disconnect the brake rod from the brake arm.
5. Disconnect the brake stopper arm from the brake panel by removing the cotter pin, stopper arm nut, washer and rubber grommet.
6. Loosen the axle holding bolt.

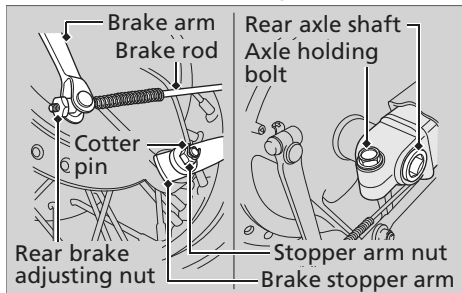

7. While holding the other end of the rear axle shaft with a wrench, remove the rear axle nut.
8. Pull the rear axle shaft out and remove the side collar.
9. Move the wheel to the right to separate it from the final drive gear case.
10. Remove the wheel.

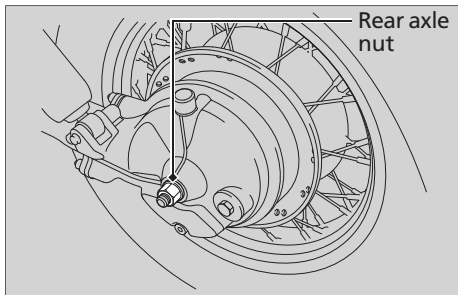

Wheel Installation (VT750C)

Before installing the wheel, check that the wheel hub and final drive gear splines are coated with molybdenum disulfide paste.

Recommended molybdenum disulfide paste:

(USA only) Pro Honda Moly 60 Paste or equivalent

1. Position the wheel between the swingarm and the final drive gear case.
 - Be sure the splines on the wheel hub fit into the final drive gear case.
2. Install the side collar into the brake panel.
3. Insert the rear axle shaft from the right side, through the right swingarm, brake panel, wheel hub and final drive gear case.

4. Reassemble the brake stopper arm. Tighten the stopper arm nut.

Torque: 16 lbf·ft (22 N·m, 2.2 kgf·m).

5. Connect the brake rod to the brake arm.
6. Adjust the rear brake pedal freeplay.

► P. 62

7. Tighten the rear axle nut.

Torque: 65 lbf·ft (88 N·m, 9.0 kgf·m).

8. Tighten the axle holding bolt.

Torque: 20 lbf·ft (27 N·m, 2.8 kgf·m).

9. After installing the wheel, apply the brake pedal several times, then check if the wheel rotates freely. Recheck the wheel if the brake drags or if the wheel does not rotate freely.

Wheel Removal (VT750CS)

1. Park on a firm, level surface.
2. Support your motorcycle securely and raise the rear wheel off the ground using a maintenance stand or a hoist.
3. Loosen the axle holding bolt.
4. While holding the outer end of the rear axle shaft with a wrench, remove the rear axle nut.
5. Remove the rear brake bracket bolt and bolt.
6. Pull the rear axle shaft out.
7. Remove the rear brake bracket, washer and side collar.

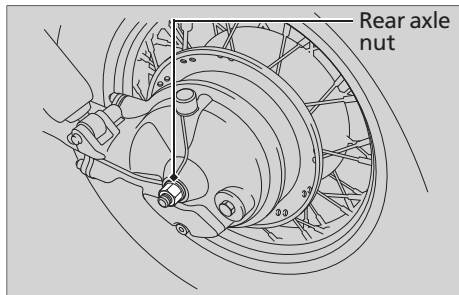
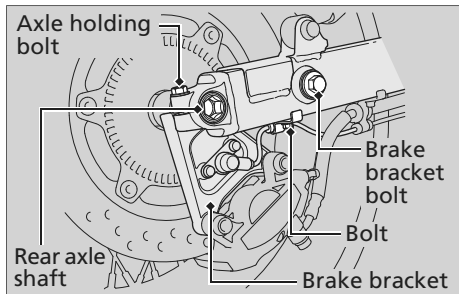

8. Move the wheel to the right to separate it from the final drive gear case.
9. Remove the wheel.
 - Support the brake caliper assembly so that it doesn't hang from the brake hose. Do not twist the brake hose.
 - Avoid getting grease, oil, or dirt on the disc or pad surfaces.
 - Do not push the brake pedal while the brake caliper is removed.

Wheel Installation (VT750CS)

Before installing the wheel, check that the wheel hub and final drive gear splines are coated with molybdenum disulfide paste.

Recommended molybdenum disulfide paste:

(USA only) Pro Honda Moly 60 paste or equivalent

1. Position the wheel between the swingarm and the final drive gear case.
 - Be sure the splines on the wheel hub fit into the final drive gear case.
2. Install the side collar into the wheel hub.
3. Install the rear brake bracket, washer, bolt and rear brake bracket bolt.
4. Insert the rear axle shaft from the right side, through the right swingarm, rear brake bracket, wheel hub and final drive gear case.

5. Tighten the nut and bolt.

Rear brake bracket bolt:

Torque: 51 lbf·ft (69 N·m, 7.0 kgf·m).

Rear axle nut:

Torque: 65 lbf·ft (88 N·m, 9.0 kgf·m).

Axle holding bolt:

Torque: 20 lbf·ft (27 N·m, 2.8 kgf·m).

6. After installing the wheel, apply the brake pedal several times, then check if the wheel rotates freely. Recheck the wheel if the brake drags or if the wheel does not rotate freely.

Muffler Installation

Before installing the muffler, replace the muffler gasket with a new gasket.

1. Tighten the nuts and bolts.

Exhaust pipe joint nut:

Torque: 18 lbf·ft (25 N·m, 2.5 kgf·m).

Muffler bracket nut:

Torque: 20 lbf·ft (27 N·m, 2.8 kgf·m).

2. Reinstall the right footpeg.
Tighten the nut and bolts.

Footpeg bolt A, B and nut:

Torque: 29 lbf·ft (39 N·m, 4.0 kgf·m).

Battery Goes Dead

Charge the battery using a motorcycle battery charger.

Remove the battery from the motorcycle before charging.

Do not use an automobile-type battery charger, as these can overheat a motorcycle battery and cause permanent damage.

If the battery does not recover after recharging, contact your dealer.

NOTICE

Jump starting using an automobile battery is not recommended, as this can damage your motorcycle's electrical system.

Burned-out Light Bulb

Follow the procedure below to replace a burned-out light bulb.

Turn the ignition switch to the OFF position. Allow the bulb to cool before replacing it. Do not use bulbs other than those specified. Check the replacement bulb for correct operation before riding.

For the light bulb wattage, see "Specifications." [▶ P. 122](#)

Headlight Bulb

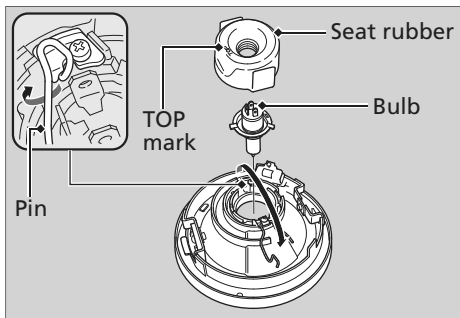
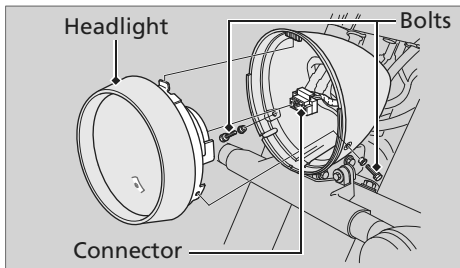

1. Remove the bolts from the headlight case.
2. Gently pull the lower end of the headlight forward and remove the headlight.
3. Disconnect the connector.
4. Remove the seat rubber.
5. Unhook the pin and remove the bulb.
6. Install a new bulb and parts in the reverse order of removal.
 - Install the seat rubber with its TOP mark facing up.

Do not touch the glass surface with your fingers. If you touch the bulb with your bare hands, clean it with a cloth moistened with isopropyl (rubbing) alcohol.

Brake/Taillight Bulb

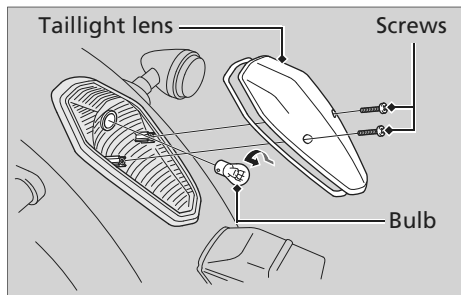

1. Remove the taillight lens by removing the screws.
2. Slightly press the bulb in and turn it counterclockwise.
3. Install a new bulb and parts in the reverse order of removal.
 - After putting back the lens packing in place, install the taillight lens.

Front/Rear Turn Signal Bulb

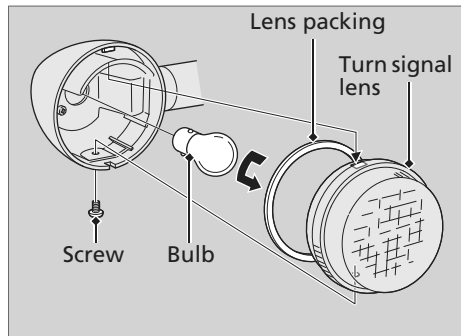

1. Remove the turn signal lens and lens packing by removing the screw.
2. Slightly press the bulb and turn it counterclockwise.
3. Install a new bulb and parts in the reverse order of removal.

License Plate Light Bulb

1. Remove the screws and license light cover.
2. Pull the bulb out of the socket without turning it.
3. Install a new bulb and parts in the reverse order of removal.

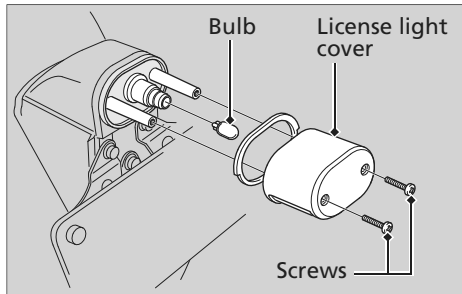

Blown Fuse

Before handling fuses, see “Inspecting and Replacing Fuses.” ► P. 41

Fuse Box Fuses (VT750C)

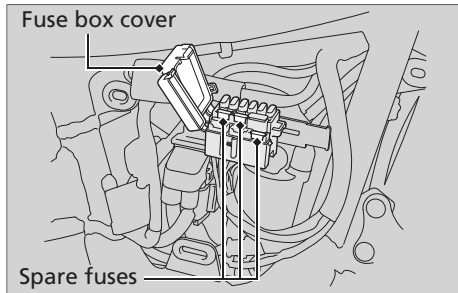

1. Remove the right side cover. ► P. 49
2. Open the fuse box cover.
3. Pull the fuses out one by one check for a blown fuse. Always replace a blown fuse with a spare of the same rating.
4. Close the fuse box cover.
5. Reinstall the right side cover.

NOTICE

If a fuse fails repeatedly, you likely have an electrical problem. Have your motorcycle inspected by your dealer.

■ Main Fuse (VT750C)

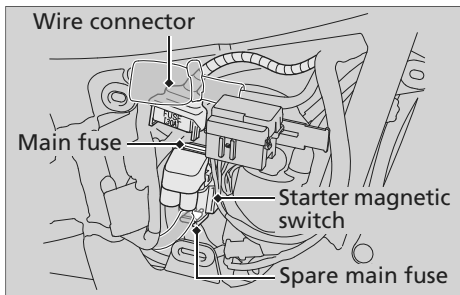

1. Remove the right side cover. ► P. 49
2. Disconnect the wire connector of the starter magnetic switch.
3. Pull the main fuses out and check for a blown fuse. Always replace a blown fuse with a spare of the same rating.
► Spare main fuse is located under the starter magnetic switch.
4. Reinstall parts in the reverse order of removal.

Fuse Box Fuses (VT750CS)

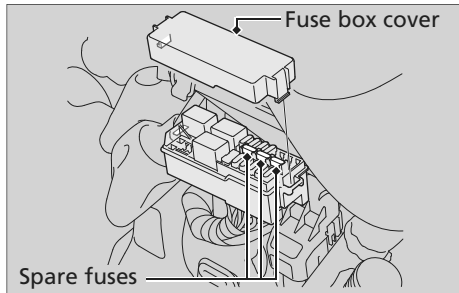

1. Remove the left side cover. [▶ P. 49](#)
2. Remove the fuse box cover.
3. Pull the fuses out one by one check for a blown fuse. Always replace a blown fuse with a spare of the same rating.
4. Reinstall parts in the reverse order of removal.

Main Fuse & FI Fuse (VT750CS)

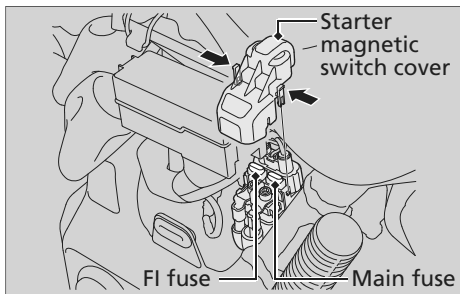

1. Remove the left side cover. ► P. 49
2. Remove the starter magnetic switch cover.
3. Pull the main fuse and FI fuse out one by one and check for a blown fuse. Always replace a blown fuse with a spare of the same rating.
 - Spare fuses are provided in the fuse box. ► P. 97

4. Reinstall parts in the reverse order of removal.

Information

Keys	P. 100
Instruments, Controls, & Other Features ...	P. 101
Caring for Your Motorcycle	P. 102
Storing Your Motorcycle	P. 105
Transporting Your Motorcycle	P. 105
You & the Environment	P. 106
Vehicle Identification Number	P. 107
Emission Control Systems	P. 108
Catalytic Converter	P. 113
Oxygenated Fuels	P. 114
Authorized Manuals	P. 115
Warranty Coverage and Service	P. 116

Honda Contacts	P. 117
USA Reporting Safety Defects	P. 119

Keys

Ignition key

Be sure to record the key number provided with the original keys. Store the spare key and recorded key number in a safe location.

To make a duplicate, take the spare key or the key number to a locksmith.

If you lose all keys and the key number, the ignition switch assembly will probably have to be removed by your dealer to determine the key number.

A metal key holder may cause damage to the area surrounding the ignition switch.

Instruments, Controls, & Other Features

Ignition Switch

The headlight is always on when the ignition switch is ON. Leaving the ignition switch ON with the engine stopped will drain the battery.

Do not turn the key while riding.

Engine Stop Switch

Do not use the engine stop switch except in an emergency. Doing so when riding will cause the engine to suddenly turn off, making riding unsafe.

If you stop the engine using the engine stop switch, turn the ignition switch off. Failing to do so will drain the battery.

Odometer

The display locks at 999,999 when the readout exceeds 999,999.

Tripmeter

The tripmeter returns to 0.0 when the read-out exceeds 999.9.

Document Bag

The owner's manual, registration, and insurance information can be stored in the plastic document bag located under the seat.

Ignition Cut-off System

A banking (lean angle) sensor automatically stops the engine and fuel pump if the motorcycle falls over. To reset the sensor, you must turn the ignition switch to OFF and back to the ON position before the engine can be restarted.

Caring for Your Motorcycle

Frequent cleaning and polishing is important to ensure the life of your Honda. A clean motorcycle makes it easier to spot potential problems.

In particular, seawater and salts used to prevent ice on roads promote the formation of corrosion. Always wash your motorcycle thoroughly after riding on coastal or treated roads.

Washing

Allow the engine, muffler, brakes, and other high-temperature parts to cool before washing.

1. Rinse your motorcycle thoroughly using a garden hose to remove loose dirt.
2. If necessary, use a sponge or a soft towel with mild cleaner to remove road grime.
 - ▶ Clean the headlight lens, panels, and other plastic components with extra care to avoid scratching them.

Avoid directing water into the air cleaner, muffler, and electrical parts.

3. Thoroughly rinse your motorcycle with plenty of clean water and dry with a soft, clean cloth.
4. After the motorcycle dries, lubricate any moving parts.
 - ▶ Make sure that no lubricant spills onto the brakes or tires. Brake discs, pads, drum or shoes contaminated with oil will suffer greatly reduced braking effectiveness and can lead to a crash.
5. Apply a coat of wax to prevent corrosion.
 - ▶ Avoid products that contain harsh detergents or chemical solvents. These can damage the metal, paint, and plastic on your motorcycle.
Keep the wax clear of the tires and brakes.
 - ▶ If your motorcycle has any matte painted parts, do not use wax or polishing compounds on the matte painted surface. These can damage or discolor the matte finish.

Washing Precautions

Follow these guidelines when washing:

- Do not use high-pressure washers:
 - ▶ High-pressure water cleaners can damage moving parts and electrical parts, rendering them inoperable.
 - Do not direct water at the muffler:
 - ▶ Water in the muffler can prevent starting and causes rust in the muffler.
 - Dry the brakes:
 - ▶ Water adversely affects braking effectiveness. After washing, apply the brakes intermittently at low speed to help dry them.
 - Do not direct water under the seat:
 - ▶ Water in the under seat compartment can damage your documents and other belongings.
 - Do not direct water at the air cleaner:
 - ▶ Water in the air cleaner can prevent the engine from starting.
-
- Do not direct water near the headlight:
 - ▶ Any condensation inside the headlight should dissipate after a few minutes of running the engine.
 - Do not use wax or polishing compounds on matte painted surface:
 - ▶ Use a soft cloth or sponge, plenty of water, and a mild detergent to clean matte painted surfaces. Dry with a soft clean cloth.

Aluminum Components

Aluminum will corrode from contact with dirt, mud, or road salt. Clean aluminum parts regularly and follow these guidelines to avoid scratches:

- Do not use stiff brushes, steel wool, or cleaners containing abrasives.
- Avoid riding over or scraping against curbs.

Panels

Follow these guidelines to prevent scratches and blemishes:

- Wash gently using a soft sponge and plenty of water.
- To remove stubborn stains, use diluted detergent and rinse thoroughly with plenty of water.
- Avoid getting gasoline, brake fluid, or detergents on the instruments, panels, or headlight.

Exhaust Pipe and Muffler

The exhaust is made of stainless steel, which can become tarnished with burn marks if splattered with oil or other substances when hot. To remove burn marks, use a mild abrasive compound. To remove dirt and mud, use a kitchen cleaning solution for stainless steel and wash with a soft sponge. Rinse with plenty of water to remove all residue.

NOTICE

Even though the exhaust is made of stainless steel, it can become stained. Remove all marks and blemishes as soon as they are noticed.

Storing Your Motorcycle

If you store your motorcycle outdoors, you should consider using a full-body motorcycle cover.

If you won't be riding for an extended period, follow these guidelines:

- Wash your motorcycle and wax all painted surfaces (except matte painted surfaces). Coat chrome pieces with rust-inhibiting oil.
- Place your motorcycle on a maintenance stand and position a block so that both tires are off the ground.
- After rain, remove the body cover and allow the motorcycle to dry.
- Remove the battery to prevent discharge. Charge the battery in a shaded, well-ventilated area.
 - ▶ If you leave the battery in place, disconnect the negative \ominus terminal to prevent discharge.

After removing your motorcycle from storage, inspect all maintenance items required by the Maintenance Schedule.

USA For more information about storage, refer to the Honda Winter Storage Guide, available from your dealer.

Transporting Your Motorcycle

If your motorcycle needs to be transported, it should be carried on a motorcycle trailer or a flatbed truck or trailer that has a loading ramp or lifting platform, and motorcycle tie-down straps. Never try to tow your motorcycle with a wheel or wheels on the ground.

NOTICE

Towing your motorcycle can cause serious damage to the transmission.

You & the Environment

Owning and riding a motorcycle can be enjoyable, but you must do your part to protect the environment.

Choose Sensible Cleaners

Use a biodegradable detergent when you wash your motorcycle. Avoid aerosol spray cleaners that contain chlorofluorocarbons (CFCs) which damage the atmosphere's protective ozone layer.

Recycle Wastes

Put oil and other toxic wastes in approved containers and take them to a recycling center. Call your local or state office of public works or environmental services to find a recycling center in your area, and to get instructions on how to dispose of non-recyclable wastes. Do not place used engine oil in the trash, or pour it down a

drain or on the ground. Used oil, gasoline, coolant, and cleaning solvents contain poisons that can hurt refuse workers and contaminate drinking water, lakes, rivers, and oceans.

Vehicle Identification Number

The VIN and engine serial numbers uniquely identify your motorcycle and are required in order to register your motorcycle. They may also be required when ordering replacement parts. The VIN is stamped on the right side of the steering head and also appears on the Safety Certification Label attached to the right side of the frame.

The engine number is stamped on the right side of the rear cylinder.

You should record these numbers and keep them in a safe place.

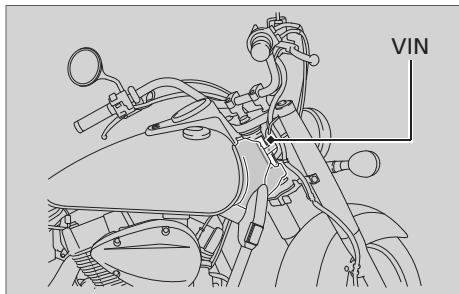
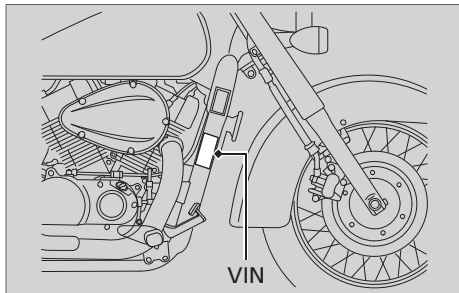

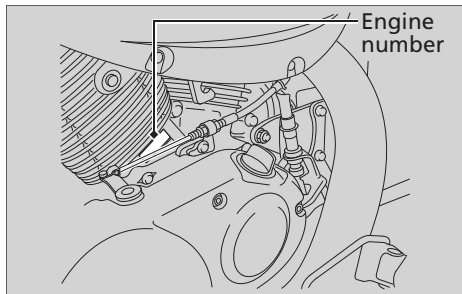

Emission Control Systems

Your motorcycle engine emits combustion byproducts, including carbon monoxide (CO), oxides of nitrogen (NO_x), and hydrocarbons (HC). Gasoline evaporation also emits hydrocarbons. Controlling the production of NO_x, CO, and HC is important for the environment.

Exhaust Emission Requirements

The U.S. Environmental Protection Agency (EPA), the California Air Resources Board (CARB), and Environment Canada (EC) require that your motorcycle comply with applicable exhaust, crankcase, and fuel permeation emission standards during its useful life, when operated and maintained according to the instructions provided.

CARB also requires that your motorcycle comply with applicable evaporative emission requirements during its useful life, when operated and maintained according to the instructions provided.

Compliance with the terms of the Distributor's Warranties for Honda Motorcycle Emission Control Systems is necessary in order to maintain a valid emissions system warranty (USA only). The Vehicle Emission Control Information label is attached to the left side of the frame.

Vehicle emission control information label

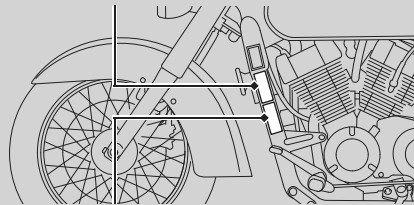

Vehicle emission control information label

Canada only

Noise Emission Requirements

The EPA requires that motorcycles built after January 1, 1983 comply with applicable noise emission standards for one year or 3,730 miles (6,000 km) after the time of purchase when operated and maintained according to the instructions provided.

Exhaust Emission Control System

The exhaust emission control system includes the following components that should not need adjustment, although periodic inspection by your Honda dealer is recommended.

PGM-FI System

The PGM-FI (programmed fuel injection) system uses sequential multiport fuel injection, and is comprised of air intake, engine control, fuel control, and exhaust control subsystems.

The engine control module (ECM) uses sensors to determine how much air enters the engine, and then controls how much fuel to inject.

Ignition Timing Control System

The ignition timing control system adjusts the ignition timing to reduce the amount of HC, CO, and NOx produced.

Secondary Air Injection System

The secondary air injection system adds filtered air into the exhaust gas to help improve emission control performance.

Catalytic Converters

The exhaust system contains one or more catalytic converters. Catalytic converters use a catalyst to convert most of the harmful exhaust gas compounds into harmless compounds.

Evaporative Emission Control System

50 STATE (meets California)

An evaporative emissions control system uses a canister filled with charcoal to absorb fuel vapor from the fuel tank while the engine is off. The vapor is drawn into the engine and burned while riding.

Crankcase Emissions Control System

The engine is equipped with a closed crankcase system to prevent discharging crankcase emissions into the atmosphere.

Blow-by gas is returned to the combustion chamber through the air cleaner and the intake manifold.

Fuel Permeation Emission Control

The fuel tank, fuel hoses, and fuel vapor charge hoses use fuel permeation control technologies to prevent fuel vapor emissions.

Tampering with these components to reduce or defeat the effectiveness of the fuel permeation technologies is prohibited.

Noise Emission Control System

TAMPERING WITH THE NOISE CONTROL SYSTEM IS PROHIBITED:

U. S. federal law prohibits, and Canadian provincial laws may prohibit, the following acts or the causing thereof: (1) The removal or rendering inoperative by any person, other than for purposes of maintenance, repair or replacement, of any device or element of design incorporated into any new vehicle for the purpose of noise control prior to its sale or delivery to the ultimate purchaser or while it is in use; or (2) the use of the vehicle after such device or element of design has been removed or rendered inoperative by any person.

AMONG THOSE ACTS PRESUMED TO CONSTITUTE TAMPERING ARE THE FOLLOWING ACTS:

- Removal of, or puncturing the muffler, baffles, header pipes or any other component which conducts exhaust gases.
- Removal of, or puncturing of any part of the intake system.
- Lack of proper maintenance.
- Removing or disabling any emissions compliance component, or replacing any compliance component with a non-compliant component.

Problems Affecting Motorcycle Exhaust Emissions

Have your motorcycle inspected and repaired by your Honda dealer if you experience any of the following symptoms:

- Hard starting or stalling after starting
- Rough idling
- Misfiring or backfiring during acceleration
- Poor engine performance and poor fuel economy

Catalytic Converter

This motorcycle is equipped with an oxidation catalytic converter. The catalytic converter contain precious metals that serve as catalysts in high temperature chemical reactions that convert hydrocarbons (HC) and carbon monoxide (CO) in the exhaust gasses into safe compounds.

A defective catalytic converter contributes to air pollution and can impair your engine's performance. A replacement unit must be an original Honda part or equivalent.

Follow these guidelines to protect your motorcycle's catalytic converter.

- Always use unleaded gasoline. Leaded gasoline will damage the catalytic converter.
- Keep the engine in good running condition. A poorly running engine can cause the catalytic converter to overheat causing damage to the converter or the motorcycle.
- If your engine is misfiring, backfiring, stalling, or otherwise not running properly, stop riding and turn off the engine. Have your motorcycle serviced as soon as possible.

Oxygenated Fuels

Some conventional fuels blended with alcohol or an ether compound are available in some locales to help reduce emissions to meet clean air standards. These gasolines are collectively referred to as oxygenated fuels. If you plan to use oxygenated fuel, check that it is unleaded and meets the minimum octane rating and blend requirement.

The following fuel blends are EPA-approved and have been approved for use in your motorcycle:

- Ethanol (ethyl alcohol) up to 10 % by volume.
 - ▶ Gasoline containing ethanol may be marketed under the name Gasohol.
- Methanol (methyl alcohol) up to 5 % by volume that contain cosolvents and corrosion inhibitors to protect the fuel system. Never use a blend containing more than 5 %.

If you accidentally fill your fuel tank with an oxygenated fuel containing higher percentages, you may experience performance problems. To resolve the problem, have your dealer drain the fuel tank and replace with the correct fuel. Fuel system or performance problems resulting from the use of an oxygenated fuel containing higher percentages are not covered by your warranty.

NOTICE

Improper use of oxygenated fuels can damage metal, rubber, and plastic parts of your fuel system.

Oxygenated fuel can also damage paint. Damage caused by spilled fuel is not covered by warranty.

If you notice any undesirable operating symptoms or performance problems, try a different brand of gasoline.

Authorized Manuals

The Service Manual used by your authorized dealer is available from your Honda dealer or Helm, Inc.

(USA only, Canada: See your Honda dealer to order authorized manuals.)

Also available, but not necessary to service your model, is the Honda Common Service Manual, which explains basic service information for

various systems on Honda motorcycles, scooters, and all-terrain vehicles.

These Honda manuals are written for the professional technician. However, if you possess the proper tools, observe the safety standards, and are mechanically capable, you should find them easy to use.

Special Honda tools are necessary for some procedures.

Publication Item No.	Description
61MEG55	2015 VT750C/CS Service Manual
61CSM00	Common Service Manual
31MEG710	2015 VT750C/CS Owner's Manual

Order On-Line: www.helminc.com

Order Toll Free: 1-888-CYCLE93 (1-888-292-5393)

(NOTE: For Credit Card Orders Only)

Monday – Friday 8:00 AM – 6:00 PM EST

Warranty Coverage and Service

Coverage

Your new Honda is covered by the following warranties:

- Motorcycle Limited Warranty
- Emission Control System Warranty
- Noise Control Warranty (USA only)

The responsibilities, restrictions, and exclusions that apply to these warranties are explained in the Warranties Booklet given to you by your Honda dealer at the time of purchase. Always keep your Honda owner's card with your Warranties Booklet.

Canada Please refer to the Warranty Booklet posted on our website at www.honda.ca.

It is important to realize that your warranty applies only to defects in material or

workmanship of your Honda. Your warranty coverage does not apply to the normal wear and deterioration associated with use of the motorcycle.

Your warranty coverage is not voided if you perform your own maintenance. However, failures that occur due directly to improper maintenance are not covered by these warranties.

You can extend almost all of your warranty coverage through the Honda Protection Plan (USA only). For more information, see your Honda dealer.

Service

Please remember that maintenance recommended in the Maintenance Schedule is not included in your warranty coverage.

If you believe you have a problem with your

motorcycle, call the service department of your Honda dealer. Make an appointment for an inspection and diagnosis. You will be asked to authorize that inspection, and your dealer will return the results of the inspection. If a problem exists and is covered under warranty, your dealer will perform the warranty repairs. If you have any questions about your warranty coverage or the nature of the repair, talk to the Service Manager of your Honda dealer.

If a misunderstanding occurs and you aren't satisfied with your dealer's handling of the situation, we suggest you discuss your problem with the appropriate member of the dealership's management team. If you are still not satisfied, contact the owner of the dealership or their designated representative.

Honda Contacts

American Honda Motor Co., Inc.

If you wish to contact Honda directly to comment on your experiences with your motorcycle or with your dealer, please send your comments to the following address:

Motorcycle Division,
American Honda Motor Co., Inc.,
P.O. Box 2200, Torrance,
CA 90509-2200
Mailstop: 100-4C-7B,
Telephone: (866) 784-1870.

Canada Honda Canada Inc., Customer Relation Dept, 180 Honda Boulevard, Markham, Ontario L6C 0H9, telephone: (888) 946-6329, facsimile: (877) 939-0909
E-mail: honda_cr@ch.honda.com

Honda Contacts

Please include the following information in your letter:

- Name, address, and telephone number
- Product model, year, and VIN
- Date of purchase
- Dealer name and address

We will likely ask your Honda dealer to respond, or possibly acknowledge your comments directly.

Your Honda Dealer

The service department of your Honda dealer offers trained personnel to perform regular maintenance and most repairs. It has the latest available service information from Honda and also handles warranty inspections and repairs.

The parts department offers Honda Genuine Parts, Pro Honda products, Honda Genuine Accessories (USA only), and Honda accessories

and products (Canada only) that provide the same quality that went into your motorcycle.

The sales department offers the Honda Protection Plan to extend almost all of your warranty coverage (USA only).

Your Honda dealer can also supply information about, riding events, and information about safety training available in your local area, and the Honda Rider's Club of America (USA only).

Honda Rider's Club of America (HRCA)

The Honda Rider's Club of America (HRCA) sponsors local riding chapters at Authorized Honda Dealerships across the country. You can log on to the HRCA Clubhouse website for more information at www.hrca.honda.com.

USA Reporting Safety Defects

If you believe that your vehicle has a defect which could cause a crash or could cause injury or death, you should immediately inform the National Highway Traffic Safety Administration (NHTSA) in addition to notifying American Honda Motor Co., Inc.

If NHTSA receives similar complaints, it may open an investigation, and if it finds that a safety defect exists in a group of vehicles, it may order a recall and remedy campaign. However, NHTSA cannot become involved in individual problems between you, your dealer, or American Honda Motor Co., Inc.

To contact NHTSA, you may call the Vehicle Safety Hotline toll-free at: 1-888-327-4236

(TTY: 1-800-424-9153); go to <http://www.safercar.gov>;

or write to:

Administrator, NHTSA,
1200 New Jersey Avenue, SE.,
Washington, DC 20590.

You can also obtain other information about motor vehicle safety from:

<http://www.safercar.gov>.

Specifications

■ Main Components

Type	RC50
Overall length	98.8 in (2,510 mm)
Overall width	36.2 in (920 mm)
Overall height	44.3 in (1,125 mm)
Wheelbase	64.6 in (1,640 mm)
Minimum ground clearance	5.1 in (130 mm)
Caster angle	34° 00'
Trail	6.3 in (161 mm)
	VT750C
	50 STATE (meets California)
	562 lb (255 kg)
	49 STATE 560 lb (254 kg)
	Canada model 559 lb (253 kg)
	VT750CS
	50 STATE (meets California)
	573 lb (260 kg)
	49 STATE 570 lb (259 kg)

*1 Including rider, passenger, all luggage, and accessories

*2 Includes the weight of the luggage and added accessories.

Maximum weight capacity* ¹	401 lb (182 kg)
Maximum luggage weight* ²	96 lb (43.5 kg)
	Luggage 40 lb (18 kg)
	Accessories 56 lb (25.5 kg)
Passenger capacity	Rider and 1 passenger
Minimum turning radius	10.8 ft (3.3 m)
Displacement	45.4 cu-in (745 cm ³)
Bore x stroke	3.11 x 2.99 in (79.0 x 76.0 mm)
Compression ratio	9.6:1
	Unleaded gasoline
Fuel	Recommended fuel octane number: Pump Octane Number (PON) 86 or higher.
Tank capacity	3.70 US gal (14.0 liters)
Battery	YTZ14S
	12V-11.2Ah (10 HR)
	1st 2.400
	2nd 1.550
Gear ratios	3rd 1.173
	4th 0.960
	5th 0.851
Reduction ratios (primary / secondary / final)	1.763 / 0.868 / 3.090

■ Service Data

Tire size	Front	120/90-17M/C (64S)
	Rear	160/80-15M/C (74S)
Tire type	bias-ply, tube	
Recommended Tires	Front	DUNLOP D404 FG
		BRIDGESTONE G701
	Rear	CHENG SHIN M6002
		DUNLOP D404
Tire air pressure	Front	29 psi (200 kPa, 2.00 kgf/cm ²)
	Rear	29 psi (200 kPa, 2.00 kgf/cm ²)*1 36 psi (250 kPa, 2.50 kgf/cm ²)*2
Minimum tread depth	Front	0.06 in (1.5 mm)
	Rear	0.08 in (2.0 mm)
Spark plugs	(standard)	DPR7EA-9 (NGK) or X22EPR-U9 (DENSO)
	(high speed riding)	DPR8EA-9 (NGK) or X24EPR-U9 (DENSO)
Spark plug gap	(non-adjustable)	0.031 to 0.035 in (0.80 to 0.90 mm)
Idle speed	1,200 ± 100 rpm	

*1 With less than 200 lb (90 kg) of added weight.

*2 With more than 200 lb (90 kg) of added weight.

Recommended engine oil	API Service Classification SG or higher except oils labeled as energy conserving or resource conserving on the circular API service label, SAE 10W-30, JASO T 903 standard MA, Pro Honda GN4 4-stroke oil (USA & Canada) or Honda 4-stroke oil, or an equivalent motorcycle oil	
	After draining	2.6 US qt (2.5 liters)
Engine oil capacity	After draining & filter change	2.7 US qt (2.6 liters)
	After disassembly	3.4 US qt (3.2 liters)
	Recommended final drive oil	Hypoid gear oil SAE 80
Final drive oil capacity	After draining	5.4 US oz (160 cm ³)
	After disassembly	5.7 US oz (170 cm ³)
Recommended brake (clutch) fluid	Honda DOT 4 Brake Fluid	
Cooling system capacity	2.07 US qt (1.96 liters)	
Recommended coolant	Pro Honda HP Coolant	

Specifications

■ Bulbs

Headlight	12V-60/55W
Brake/Taillight	12V-21/5W
Front turn signal lights	12V-21/5W x 2
Rear turn signal lights	12V-21W x 2
License plate light	12V-5W

■ Fuses

Main fuse	30A
FI fuse	VT750C 15A
	VT750CS 20A
Other fuses	VT750C 20A, 10A
	VT750CS 30A, 20A, 10A

■ Torque Specifications

Engine oil drain bolt	21 lbf-ft (29 N·m, 3.0 kgf·m)
Oil filter	19 lbf-ft (26 N·m, 2.7 kgf·m)
Final drive oil fill hole cap	9 lbf-ft (12 N·m, 1.2 kgf·m)
Final drive oil drain bolt	9 lbf-ft (12 N·m, 1.2 kgf·m)
Front wheel axle bolt	44 lbf-ft (59 N·m, 6.0 kgf·m)
Front wheel axle pinch bolts	16 lbf-ft (22 N·m, 2.2 kgf·m)
Rear brake stopper arm nut	16 lbf-ft (22 N·m, 2.2 kgf·m)
Rear wheel axle nut	65 lbf-ft (88 N·m, 9.0 kgf·m)
Rear wheel axle holding bolt	20 lbf-ft (27 N·m, 2.8 kgf·m)
Rear brake bracket bolt	51 lbf-ft (69 N·m, 7.0 kgf·m)
Exhaust pipe joint nuts	18 lbf-ft (25 N·m, 2.5 kgf·m)
Muffler bracket nut	20 lbf-ft (27 N·m, 2.8 kgf·m)
Footpeg bolt A, B and nut	29 lbf-ft (39 N·m, 4.0 kgf·m)

Information Record

VIN	
Engine No.	
Color Label & Code	
Owner's Name	
Address	
City/State	
Phone	
Dealer's Name	
Address	
City/State	
Phone	
Service Manager	

A

- ABS (Anti-lock Brake System)
 - Indicator 20, 80
- Accessories 13
- Authorized Manuals 115

B

- Battery 39, 50
- Brake Light Switch 75

Brakes

- Fluid 59
- Pad Wear 60
- Shoe Wear 64

- Braking 10

Bulb

- Brake/Taillight 93
- Front/Rear Turn Signal 93
- Headlight 92
- License Plate Light 94

C

- Caring for Your Motorcycle 102
- Clock 18
- Clutch System 65
- Color Label 38
- Compartment
 - Owner's Manual 29
- Coolant 43, 57

D

- Digital Clock Adjustment 19

E

- Electrical Trouble 91
- Emission Control Systems 108

Engine

- Number 107
- Oil 42, 53
- Overheats 78
- Starting 24
- Stop Switch 22, 101
- Stopping 101
- Environment 106

F	
Final Drive Oil.....	43, 69
Flooded Engine.....	77
Fuel	
Recommended.....	27
Tank Capacity	27
Fuel Reserve Indicator	21
Fuses	41, 95
G	
Gasohol.....	114
Gasoline.....	27
H	
Headlight Aim.....	75
Headlight Dimmer Switch	22
Helmet Holder.....	28
High Beam Indicator.....	21
High Coolant Temperature	
Indicator	20, 78
Honda Contacts.....	117
Horn Button	22
I	
Ignition Cut-off System	
Banking Sensor.....	101
Side Stand	68
Ignition Key	100
Ignition Switch	23
Indicators	20
Information Record.....	123
Instruments.....	18
L	
Labels	7
Load Limits.....	14
Loading Guidelines	14
Low Oil Pressure Indicator	20, 79

M**Maintenance**

Fundamentals.....	36
Importance.....	31
Safety.....	32
Schedule.....	33
Maximum Weight Limit	14
Modifications	13

N

Neutral Indicator	21
--------------------------------	----

O

Odometer	18, 101
-----------------------	---------

Oil

Engine.....	42, 53
Final Drive.....	43, 69
Overheating	78
Oxygenated Fuels	114

P

Parking	12
Parts Location	16
PGM-FI (Programmed Fuel Injection)	
malfunction indicator lamp (MIL).....	20, 79
Protective Apparel	9

R**Recommended**

Final Drive Oil.....	43
Fuel.....	27
Refueling	27

Removal

Seat.....	48
Side Cover.....	49
Reporting Safety Defects (U.S.)	119
Riding Precautions	10

S	
Safety Labels	7
Safety Precautions	9
Shifting Gears.....	26
Side Stand.....	68
Side Stand Ignition Cut-off System.....	68
Specifications	120
Start Button.....	22
Starting the Engine.....	24
Steering Lock.....	23
Stopping Engine	101
Storage	
Compartment	29
Owner's Manual	29
Storing Your Motorcycle	105
Switches.....	22
T	
Throttle	73
Tires	
Air Pressure	44
Puncture.....	81
Replacing	46
Transporting Your Motorcycle	105
Tripmeter	18, 101
Turn Signal Indicator.....	21
Turn Signal Switch.....	22
V	
Vehicle Identification Number	107
W	
Warning Indicators ON	79
Warranty Coverage and Service	116
Washing Your Motorcycle	102
Weight Limit.....	14, 120
Wheels	
Front removal	82
Rear removal	84