

Contents

Motorcycle Safety P. 2

Operation Guide P. 16

Maintenance P. 31

Troubleshooting P. 77

Information P. 96

Specifications P. 117

Index P. 121

Welcome

Congratulations on your purchase of a new Honda motorcycle. Your selection of a Honda makes you part of a worldwide family of satisfied customers who appreciate Honda's reputation for building quality into every product.

To ensure your safety and riding pleasure:

- Read this owner's manual carefully.
- Follow all recommendations and procedures contained in this manual.
- Pay close attention to safety messages contained in this manual and on the motorcycle.

To protect your investment, we urge you to take responsibility for keeping your motorcycle well serviced and maintained. Also, observe the break-in guidelines, and always perform the pre-ride inspection and other periodic checks in this manual.

When service is required, remember that your Honda dealer knows your motorcycle best. If you have the required mechanical "know-how" and tools, you can purchase an official Honda Service Manual to help you perform many maintenance and repair tasks.

➤ [P. 112](#)

Read the warranty information thoroughly so that you understand the warranty coverage and that you are aware of your rights and responsibilities. ➤ [P. 113](#)

You may also want to visit our website at www.powersports.honda.com.

Canada www.honda.ca.

Happy riding!

California Proposition 65 Warning

WARNING: This product contains or emits chemicals known to the State of California to cause cancer and birth defects or other reproductive harm.

A Few Words About Safety

Your safety, and the safety of others, is very important. Operating this motorcycle safely is an important responsibility.

To help you make informed decisions about safety, we have provided operating procedures and other information on safety labels and in this manual. This information alerts you to potential hazards that could hurt you or others.

Of course, it is not practical or possible to warn you about all hazards associated with operating or maintaining a motorcycle. You must use your own good judgement.

You will find important safety information in a variety of forms, including:

- Safety labels on the motorcycle
- Safety Messages preceded by a safety alert symbol and one of three signal words: DANGER, WARNING, or CAUTION.

These signal words mean:

DANGER

You **WILL** be **KILLED** or **SERIOUSLY HURT** if you don't follow instructions.

WARNING

You **CAN** be **KILLED** or **SERIOUSLY HURT** if you don't follow instructions.

CAUTION

You **CAN** be **HURT** if you don't follow instructions.

Other important information is provided under the following titles:

NOTICE Information to help you avoid damage to your motorcycle, other property, or the environment.

Motorcycle Safety

This section contains important information for safe riding of your motorcycle.
Please read this section carefully.

Safety Guidelines	P. 3
Safety Labels	P. 7
Safety Precautions	P. 9
Riding Precautions	P. 10
Accessories & Modifications	P. 13
Loading	P. 14

Safety Guidelines

Follow these guidelines to enhance your safety:

- Perform all routine and regular inspections specified in this manual.
- Stop the engine and keep sparks and flame away before filling the fuel tank.
- Do not run the engine in enclosed or partly enclosed areas. Carbon monoxide in exhaust gases is toxic and can kill you.

Always Wear a Helmet

It's a proven fact: helmets and protective apparel significantly reduce the number and severity of head and other injuries. So always wear an approved motorcycle helmet and protective apparel. ➤ P. 9

Before Riding

Make sure that you are physically fit, mentally focused and free of alcohol and drugs. Check that you and your passenger are both wearing an approved motorcycle helmet and protective apparel. Instruct your passenger on holding onto the seat strap or your waist, leaning with you in turns, and keeping their feet on the footpegs, even when the motorcycle is stopped.

Take Time to Learn & Practice

Even if you have ridden other motorcycles, practice riding in a safe area to become familiar with how this motorcycle works and handles, and to become accustomed to the motorcycle's size and weight.

Safety Guidelines

We recommend that all riders take a certified course approved by the Motorcycle Safety Foundation (MSF). New riders should start with the basic course, and even experienced riders will find the advanced course beneficial. For information about the MSF training course nearest you, call the national toll-free number: (800) 446-9227.

USA Other riding tips can be found in the You and Your Motorcycle Riding Tips booklet that came with your motorcycle.

Ride Defensively

Always pay attention to other vehicles around you, and do not assume that other drivers see you. Be prepared to stop quickly or perform an evasive maneuver.

Make Yourself Easy to See

Make yourself more visible, especially at night, by wearing bright reflective clothing, positioning yourself so other drivers can see you, signaling before turning or changing lanes, and using your horn when necessary.

Ride within Your Limits

Never ride beyond your personal abilities or faster than conditions warrant. Fatigue and inattention can impair your ability to use good judgement and ride safely.

Don't Drink and Ride

Alcohol and riding don't mix. Even one alcoholic drink can reduce your ability to respond to changing conditions, and your reaction time gets worse with every additional drink. Don't drink and ride, and don't let your friends drink and ride either.

Keep Your Honda in Safe Condition

It's important to keep your motorcycle properly maintained and in safe riding condition.

Inspect your motorcycle before every ride and perform all recommended maintenance. Never exceed load limits (➤ P. 14), and do not modify your motorcycle or install accessories that would make your motorcycle unsafe (➤ P. 13).

If You are Involved in a Crash

Personal safety is your first priority. If you or anyone else has been injured, take time to assess the severity of the injuries and whether it is safe to continue riding. Call for emergency assistance if needed. Also follow applicable laws and regulations if another person or vehicle is involved in the crash.

If you decide to continue riding, first evaluate the condition of your motorcycle. If the engine is still running, turn it off. Inspect for fluid leaks,

check the tightness of critical nuts and bolts, and check the handlebar, control levers, brakes, and wheels. Ride slowly and cautiously. Your motorcycle may have suffered damage that is not immediately apparent. Have your motorcycle thoroughly checked at a qualified service facility as soon as possible.

Carbon Monoxide Hazard

Exhaust contains poisonous carbon monoxide, a colorless, odorless gas. Breathing carbon monoxide can cause loss of consciousness and may lead to death.

If you run the engine in a confined or even partly enclosed area, the air you breathe could contain a dangerous amount of carbon monoxide. Never run your motorcycle inside a garage or other enclosure.

WARNING

Carbon monoxide gas is toxic.
Breathing it can cause
unconsciousness and even kill you.

Avoid any areas or activities that
expose you to carbon monoxide.

Safety Labels

Safety and information labels on your motorcycle provide important safety information and may warn you of potential

hazards that could cause serious injury. Read these labels carefully and don't remove them. If a label comes off or becomes hard to read, contact your dealer for a replacement.

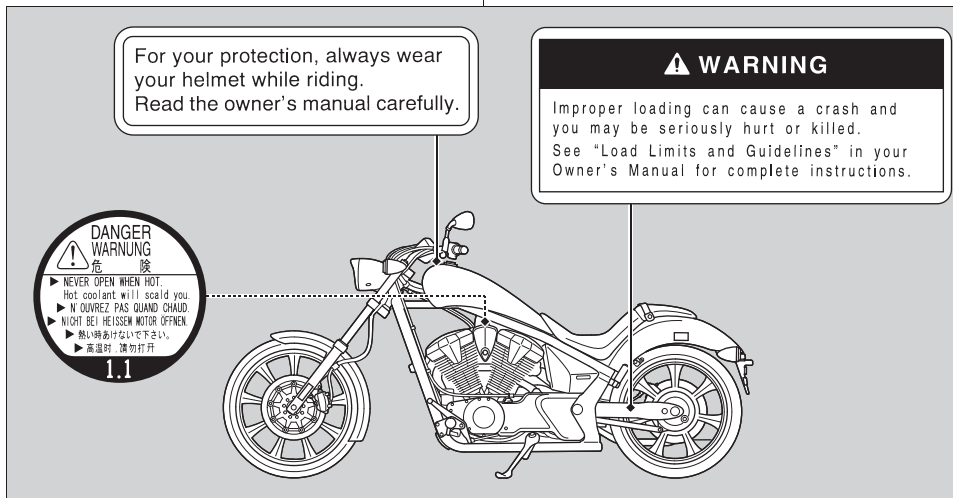

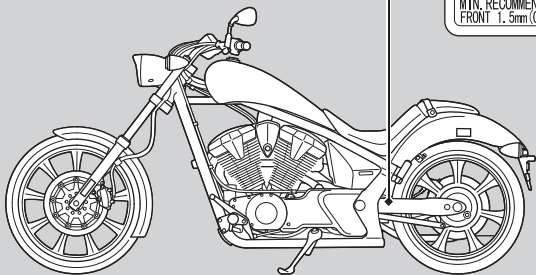

TIRE INFORMATION

COLD TIRE PRESSURES :

[UP TO MAXIMUM WEIGHT CAPACITY]	FRONT	225kPa	2.25kgf/cm ²	33psi.
	REAR	280kPa	2.80kgf/cm ²	41psi.
[UP TO 90kg (200lbs.) LOAD]	FRONT	225kPa	2.25kgf/cm ²	33psi.
	REAR	280kPa	2.80kgf/cm ²	41psi.

MAXIMUM WEIGHT CAPACITY : 146 kg (322 lbs.)

TIRE SIZE : FRONT 90/90-21M/C 54H REAR 200/50R18M/C 76H

TIRE BRAND	FRONT	REAR
DUNLOP	D422F	D423
METZELER	ME 880	ME 880

Read Owner's Manual

MIN. RECOMMEND TIRE CENTER TREAD DEPTH
 FRONT 1.5mm (0.06in.) REAR 2.0mm (0.08in.)

THIS MOTORCYCLE IS EQUIPPED WITH TUBELESS TIRES.

Safety Precautions

- Ride cautiously and keep your hands on the handlebars and feet on the footpegs.
- Keep passenger's hands on to the seat strap or your waist, passenger's feet on the footpegs while riding.
- Always consider the safety of your passenger, as well as other drivers and riders.

Protective Apparel

Make sure that you and any passenger are wearing an approved motorcycle helmet, eye protection, and high-visibility protective clothing. Ride defensively in response to weather and road conditions.

■ Helmet

Should be safety-standard certified, high-visibility, and correct size for your head

- Must fit comfortably but securely, with the chin strap fastened

- Face shield with unobstructed field of vision or other approved eye protection

USA Look for a DOT (Department of Transportation) certification label on any helmet you buy.

WARNING

Not wearing a helmet increases the chance of serious injury or death in a crash.

Make sure that you and any passenger always wear an approved helmet and protective apparel.

■ Gloves

Full-finger leather gloves with high abrasion resistance

Riding Precautions

Boots or Riding Shoes

Sturdy boots with non-slip soles and ankle protection

Jacket and Pants

Protective, highly visible, long-sleeved jacket and durable long pants for riding (or a protective suit).

Riding Precautions

Running-in Period

During the first 300 miles (500 km) of running, follow these guidelines to ensure your motorcycle's future reliability and performance.

- Avoid full-throttle starts and rapid acceleration.
- Avoid hard braking.
- Ride conservatively.

Brakes

Observe the following guidelines:

- Avoid excessively hard braking and sudden shifting to a lower gear.
 - ▶ Sudden braking can reduce the motorcycle's stability.
 - ▶ Where possible, reduce speed before turning; otherwise you risk wheel slippage.

- Exercise caution on low traction surfaces.
 - ▶ The wheels lock more easily on such surfaces, and braking distances are longer.
- Avoid continuous braking.
 - ▶ Repeated braking can overheat the brakes, reducing their effectiveness.

■ Combined ABS (VT1300CXA only)

Your motorcycle is equipped with a brake system that distributes the braking force between the front and rear brakes.

The distribution of the braking force applied to the front and rear brakes when operating the lever only and when operating the pedal only is different.

For full braking effectiveness, operate both the lever and pedal together.

This model is also equipped with an Anti-lock Brake System (ABS) designed to help prevent the brakes from locking up during hard braking.

- ABS does not reduce braking distance. In certain circumstances, ABS may actually result in a longer stopping distance.
- ABS does not function at speeds below 6 mph (10 km/h).
- The brake lever and pedal may recoil slightly when applying the brakes. This is normal.
- Always use the recommended tires to ensure correct ABS operation.

■ Engine Braking

Engine braking helps slow your motorcycle down when you release the throttle. For further slowing action, downshift to a lower gear. Use engine braking with intermittent use of the brakes to reduce speed when descending long, steep slopes.

Riding Precautions

Wet or Rainy Conditions

Road surfaces are slippery when wet, and wet brakes further reduce braking efficiency.

Exercise extra caution when braking in wet conditions.

If the brakes get wet, apply the brakes while riding at low speed to help them dry.

Parking

- Park on a firm, level paved surface.
- If you must park on a slight incline or loose surface, park so that the motorcycle cannot move or fall over.
- Make sure that high-temperature parts cannot come into contact with flammable materials.
- Do not touch the engine, muffler, brakes and other high-temperature parts until they cool down.

- To reduce the likelihood of theft, always lock the handlebars and remove the key when leaving the motorcycle unattended. Use of an anti-theft device is also recommended.

Parking with the Side Stand

1. Stop the engine and remove the ignition key.
2. Push the side stand down.
3. Slowly lean the motorcycle to the left until its weight rests on the side stand.
4. Turn the handlebars fully to the left.
 - ▶ Turning the handlebars to the right reduces stability and may cause the motorcycle to fall.
5. Insert the steering lock key in the steering lock, turn the key counterclockwise.
6. Push and turn the key clockwise.
7. Remove the steering lock key. [P. 23](#)

Refueling and Fuel Guidelines

Follow these guidelines to protect the engine and catalytic converter:

- Use only unleaded gasoline.
- Use recommended octane number. Using lower octane gasoline will result in decreased engine performance.
- Do not use fuels containing a high concentration of alcohol. [P. 111](#)
- Do not use stale or contaminated gasoline or an oil/gasoline mixture.
- Avoid getting dirt or water in the fuel tank.

Accessories & Modifications

We strongly advise that you do not add any accessories that were not specifically designed for your motorcycle by Honda or make modifications to your motorcycle from its original design. Doing so can make it unsafe. Modifying your motorcycle may also void your warranty and make your motorcycle illegal to operate on public roads and highways. Before deciding to install accessories on your motorcycle be certain the modification is safe and legal.

WARNING

Improper accessories or modifications can cause a crash in which you can be seriously hurt or killed.

Follow all instructions in this owner's manual regarding accessories and modifications.

Do not pull a trailer with, or attach a sidecar to, your motorcycle. Your motorcycle was not designed for these attachments, and their use can seriously impair your motorcycle's handling.

Loading

- Carrying extra weight affects your motorcycle's handling, braking and stability. Always ride at a safe speed for the load you are carrying.
- Avoid carrying an excessive load and keep within specified load limits.
 - **Maximum weight capacity** [P. 117](#)
- Tie all luggage securely, evenly balanced and close to the center of the motorcycle.
- Do not place objects near the lights or the muffler.

⚠ WARNING

Overloading or improper loading can cause a crash and you can be seriously hurt or killed.

Follow all load limits and other loading guidelines in this manual.

Parts Location

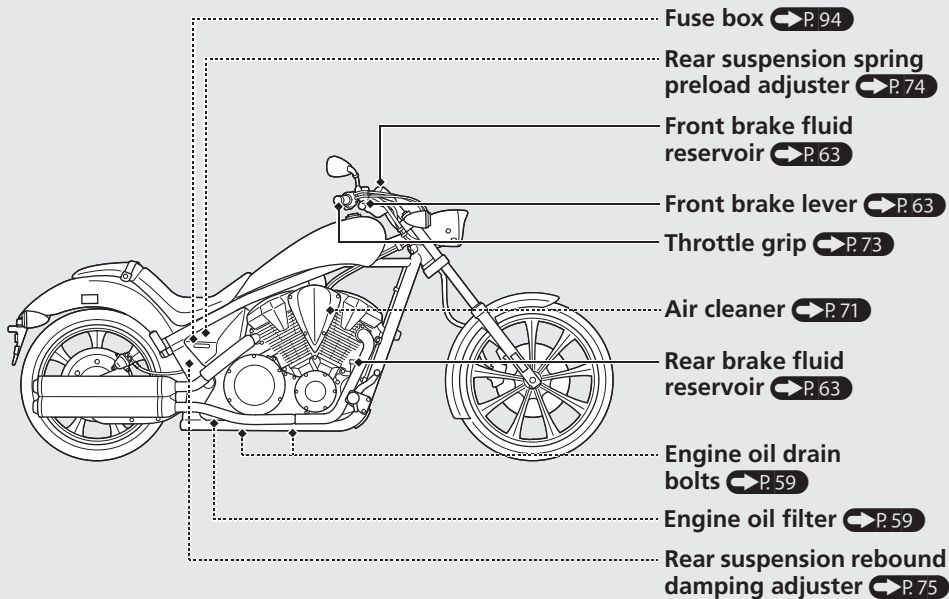

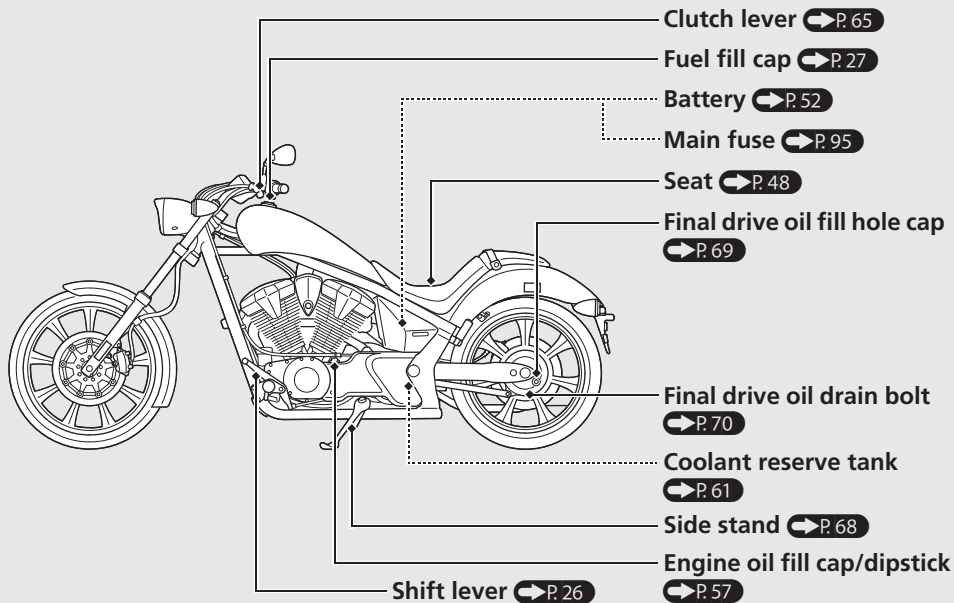

Instruments

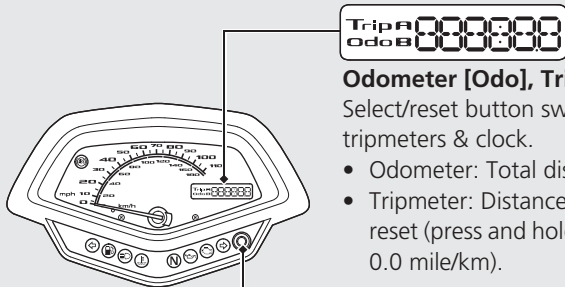

Select/Reset button



Odometer [Odo], Tripmeter [Trip A/B] & Clock
Select/reset button switches between odometer, tripmeters & clock.

- Odometer: Total distance ridden.
- Tripmeter: Distance ridden since tripmeter was reset (press and hold select/reset button to reset to 0.0 mile/km).

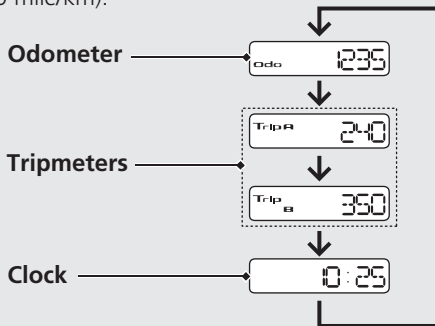

To set the clock:

- 1 Turn the ignition switch on.
- 2 Select the clock.
- 3 Press and hold the select/reset button until the hour digits start flashing.



- 4 Press the select/reset button until the desired hour is displayed.



- 5 Press and hold the select/reset button. The minute digits start flashing.





- 6 Press the select/reset button until the desired minute is displayed.

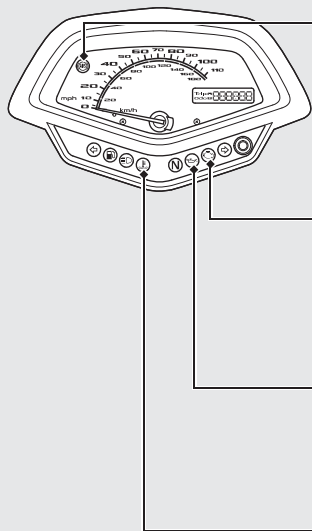

- 7 Press and hold the select/reset button until the display stop flashing. The clock is set.
 - ▶ The time can also be set by turning the ignition switch off.
 - ▶ The display will stop flashing automatically and the adjustment will be cancelled if the button is not pressed for about 30 seconds.

Indicators



 **ABS (Anti-lock Brake System) indicator (VT1300CXA)**

Comes on when the ignition switch is turned on.
Goes off when your speed reaches approximately 6 mph (10 km/h).

If it comes on while riding: ➔ P.81

 **PGM-FI (Programmed Fuel Injection) malfunction indicator lamp (MIL)**

Comes on briefly when the ignition switch is turned on with the engine stop switch in the  (Run) position.

If it comes on while engine is running: ➔ P.80

 **Low oil pressure indicator**

Comes on when the ignition switch is turned on.
Goes off when the engine starts.

If it comes on while engine is running: ➔ P.80

 **High coolant temperature indicator**

If it comes on while riding: ➔ P.79

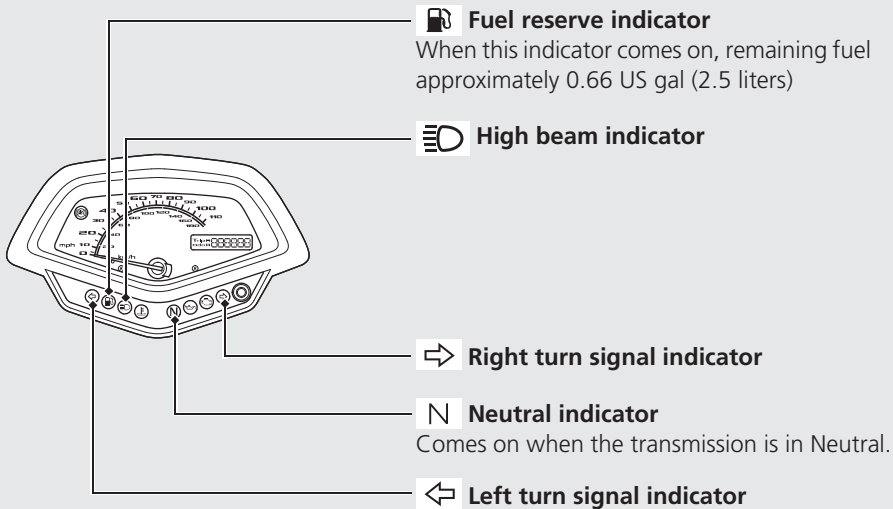

Switches

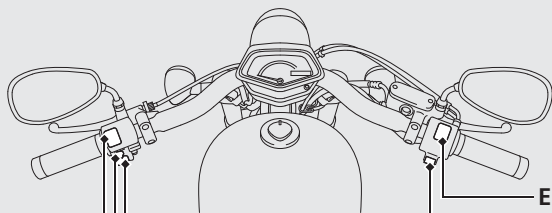



Horn button



Turn signal switch

▶ Pressing the switch turns the turn signal off.

Headlight dimmer switch

-  High beam
-  Low beam

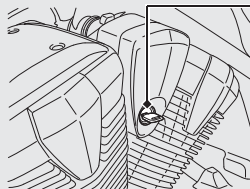

Engine stop switch

Should normally remain in the  (Run) position.

▶ In an emergency, switch to the  (Off) position (the starter motor will not operate) to stop the engine.



Start button

Headlight turns off when operating the starter motor.

Ignition Switch

Switches the electrical system on/off.

► Key can be removed when in the OFF position.

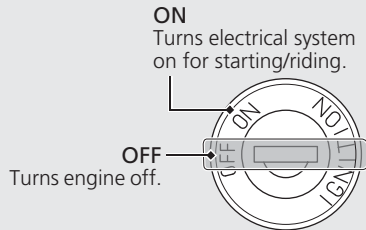

Steering Lock

Lock the steering when parking to help prevent theft.

A U-shaped wheel lock or similar device is also recommended.

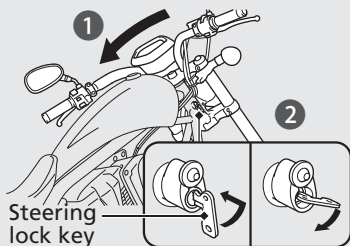

Locking

- 1 Turn the handlebars all the way to the left.
- 2 Insert the steering lock key in the steering lock, turn the key counterclockwise. Push and turn the key clockwise.
- 3 Remove the key.

Unlocking

Insert the steering lock key and turn it counterclockwise.

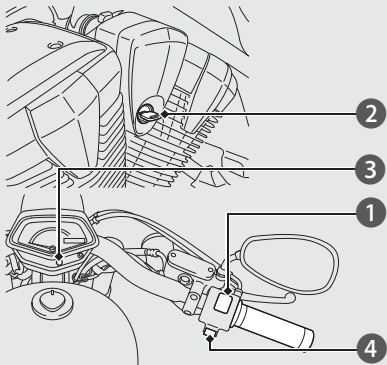

Starting the Engine

Start your engine using the following procedure, regardless of whether the engine is cold or warm.



NOTICE

- If the engine does not start within 5 seconds, turn the ignition off and wait 10 seconds before trying to start the engine again to recover battery voltage.
- Extended fast idling and revving the engine can damage the engine, and the exhaust system.
- Snapping the throttle or fast idling for more than about 5 minutes may cause exhaust pipe discoloration.

- 1 Make sure the engine stop switch is in the  (Run) position.
- 2 Turn the ignition switch to the ON position.
- 3 Shift the transmission to Neutral ( indicator comes on). Alternatively, pull in the clutch lever to start your motorcycle with the transmission in gear so long as the side stand is raised.
- 4 Press the start button with the throttle completely closed.

If the engine does not start:

- ① Open the throttle fully and press the start button for 5 seconds.
- ② Repeat the normal starting procedure.
- ③ If the engine starts, open the throttle slightly if idling is unstable.
- ④ If the engine does not start, wait 10 seconds before trying steps ① & ② again.

If Engine Will Not Start ➔ P.78

Shifting Gears

Your motorcycle transmission has 5 forward gears in a one-down, four-up shift pattern.

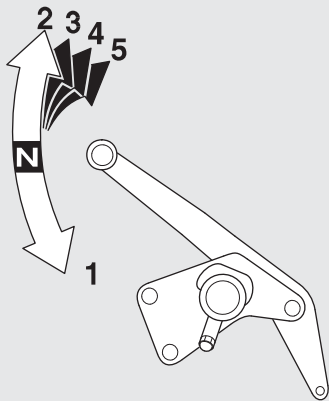

If you put the motorcycle in gear with the side stand down, the engine will shut off.

Recommended Shift Points

Shifting Up

From 1st to 2nd	12 mph (20 km/h)
From 2nd to 3rd	19 mph (30 km/h)
From 3rd to 4th	25 mph (40 km/h)
From 4th to 5th	31 mph (50 km/h)

Shifting Down

From 5th to 4th	22 mph (35 km/h)
From 4th to 3rd	16 mph (25 km/h)

NOTICE

Improper shifting can damage the engine, transmission, and drive train. Also, coasting or towing the motorcycle for long distances with the engine off can damage the transmission.

Refueling

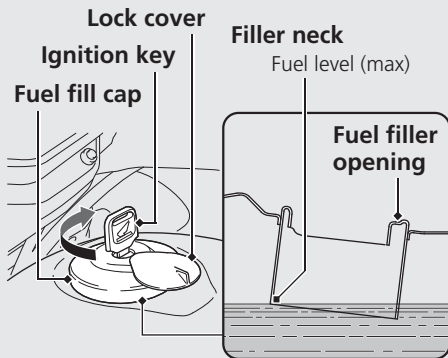

Do not fill with fuel above the filler neck.

Fuel type: Unleaded gasoline only

Recommended fuel octane number:

Pump Octane Number (PON) 86 or higher.

Tank capacity: 3.38 US gal (12.8 liters)

Refueling and Fuel Guidelines ➔ P.13

Opening the Fuel Fill Cap

Open the lock cover, insert the ignition key, and turn it clockwise to open the cap.

Closing the Fuel Fill Cap

- 1 After refueling, align the fuel cap latch with the slot in the filler neck. Push the fuel fill cap into the filler neck until it snaps closed and locks.
- 2 Remove the key and close the cover.
 - ▶ The key cannot be removed if the cap is not locked.

⚠ WARNING

Gasoline is highly flammable and explosive. You can be burned or seriously injured when handling fuel.

- Stop the engine, and keep heat, sparks, and flame away.
- Handle fuel only outdoors.
- Wipe up spills immediately.

Storage Equipment

Helmet holder is located on the left side below the seat.

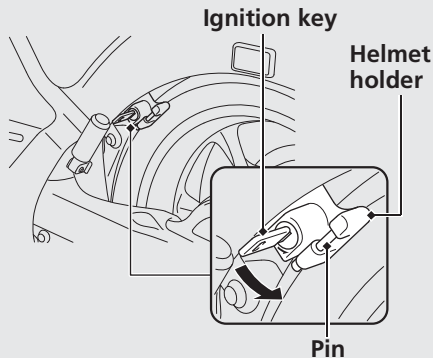

Unlocking

Insert the ignition key and turn it counterclockwise.

Locking

- 1 Hang your helmet on the holder pin and push it in to lock.
- 2 Remove the key.
 - ▶ Use the helmet holder only when parked.

⚠ WARNING

Riding with a helmet attached to the holder can interfere with the rear wheel or suspension and could cause a crash in which you can be seriously hurt or killed.

Use the helmet holder only while parked. Do not ride with a helmet secured by the holder.

Space to store a owner's manual in the document bag attached to the inside of the right side cover.

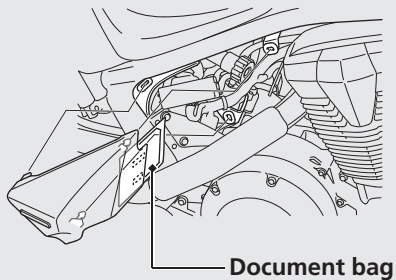

Removing the Side Cover ➔ P.50

Space to store other documents in the document bag attached to the rear fender under the seat.

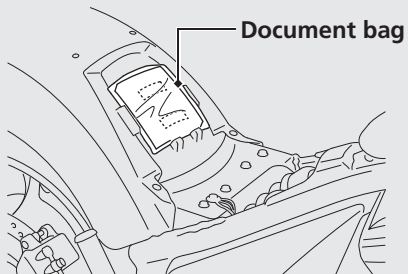

Removing the Seat ➔ P.48

The tool kit is stored on the face of the ignition switch case behind the ignition switch cover.

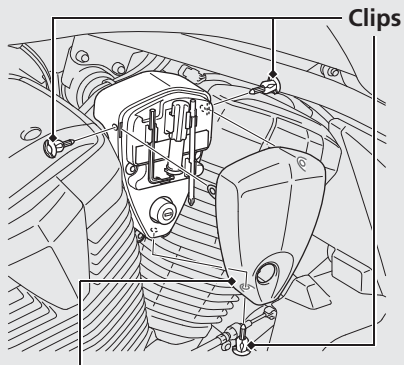

Ignition switch cover

- 1 Remove the clips. ➔ P.51
- 2 Remove the ignition switch cover.

Maintenance

Please read "Importance of Maintenance" and "Maintenance Fundamentals" carefully before attempting any maintenance. Refer to "Specifications" for service data.

An optional larger tool kit may be available. Check with your Honda dealer's parts department.

Importance of Maintenance	P. 32	Side Stand	P. 68
Maintenance Schedule	P. 34	Final Drive Oil	P. 69
Maintenance Fundamentals	P. 37	Air Cleaner	P. 71
Removing & Installing Body Components ...	P. 48	Crankcase Breather	P. 72
Seat	P. 48	Throttle	P. 73
Side Cover	P. 50	Other Adjustments	P. 74
Clip.....	P. 51	Rear Suspension	P. 74
Battery.....	P. 52	Headlight Aim	P. 76
Spark Plug	P. 53	Brake Light Switch.....	P. 76
Engine Oil	P. 57		
Coolant	P. 61		
Brakes/Clutch	P. 63		

Importance of Maintenance

Importance of Maintenance

Keeping your motorcycle well-maintained is absolutely essential to your safety and to protect your investment, obtain maximum performance, avoid breakdowns, and reduce air pollution. Maintenance is the owner's responsibility. Be sure to inspect your motorcycle before each ride, and perform the periodic checks specified in the Maintenance Schedule. ➤ P. 34

WARNING

Improperly maintaining your motorcycle or failing to correct a problem before you ride can cause a crash in which you can be seriously hurt or killed.

Always follow the inspection and maintenance recommendations and schedules in this owner's manual.

For information about the exhaust emission and noise emission requirements of the U.S. Environmental Protection Agency (EPA), the California Air Resources Board (CARB), and Environment Canada (EC). ➤ P. 105

USA

Maintenance, replacement or repair of the emission control devices and systems may be performed by any motorcycle repair establishment or individual using parts that are "certified" to EPA standards.

Maintenance Safety

Always read the maintenance instructions before you begin each task, and make sure that you have the tools, parts, and skills required. We cannot warn you of every conceivable hazard that can arise in performing maintenance. Only you can decide whether or not you should perform a given task.

Follow these guidelines when performing maintenance.







- Stop the engine and remove the key.
- Park your motorcycle on a firm, level surface using the side stand or a maintenance stand to provide support.
- Allow the engine, muffler, brakes, and other high-temperature parts to cool before servicing as you can get burned.
- Run the engine only when instructed, and do so in a well-ventilated area.

Maintenance Schedule

The maintenance schedule specifies the maintenance requirements necessary to ensure safe, dependable performance, and proper emission control.

Maintenance work should be performed in accordance with Honda's standards and specifications by properly trained and equipped technicians. Your dealer meets all of these requirements. Keep an accurate record of maintenance to help ensure that your motorcycle is properly maintained. Make sure that whomever performs the maintenance completes this record.

All scheduled maintenance is considered a normal owner operating cost and will be charged for by your dealer. Retain all receipts. If you sell the motorcycle, these receipts should be transferred with the motorcycle to the new owner.

Items		Frequency	Odometer Reading*1							Refer to page	
			x 1,000 mi	0.6	4	8	12	16	20		24
			x 1,000 km	1.0	6.4	12.8	19.2	25.6	32.0		38.4
Emission-related Items	Fuel Line					I		I		I	-
	Throttle Operation					I		I		I	73
	Air Cleaner*2						R			R	71
	Crankcase Breather*3				C	C	C	C	C	C	72
	Spark Plug				I	R	I	R	I	R	53
	Valve Clearance			I		I		I		I	-
	Engine Oil		Initial = 600 mi (1,000 km) or 1 month: R Regular = Every 8,000 mi (12,800 km) or 12 months: R							57	
	Engine Oil Filter			R		R		R		R	59
	Engine Idle Speed			I	I	I	I	I	I	I	-
	Radiator Coolant*4					I		I		R	61
	Cooling System					I		I		I	-
	Secondary Air Supply System					I		I		I	-
Evaporative Emission Control System*5						I			I	-	
Final Drive Oil					I		I		R	69	

Maintenance Level

 : Intermediate. We recommend service by your Honda dealer, unless you have the necessary tools and are mechanically skilled. Procedures are provided in an official Honda Service Manual (P. 112).

 : Technical. In the interest of safety, have your motorcycle serviced by your dealer.

Maintenance Schedule

		Frequency	Odometer Reading*1							Refer to page	
			× 1,000 mi	0.6	4	8	12	16	20		24
Items			× 1,000 km	1.0	6.4	12.8	19.2	25.6	32.0	38.4	
Non-Emission-Related Items	Brake Fluid*4				I	I	R	I	I	R	63
	Brake Pad Wear				I	I	I	I	I	I	64
	Brake System			I		I		I		I	63
	Brake Light Switch	🔧				I		I		I	76
	Headlight Aim	🔧				I		I		I	76
	Clutch System			I	I	I	I	I	I	I	65
	Side Stand					I		I		I	68
	Suspension	🔧				I		I		I	74
	Nuts, Bolts, Fasteners	🔧		I		I		I		I	-
	Wheels/Tires	🔧				I		I		I	44
	Steering Head Bearings	🔧		I		I		I		I	-

Maintenance Legend

I : Inspect (clean, adjust, lubricate, or replace, if necessary)

C : Clean

R : Replace

Notes:

*1 : At higher odometer readings, repeat at the frequency interval established here.

*2 : Service more frequently when riding in unusually wet or dusty areas.

*3 : Service more frequently if the motorcycle is ridden often at full throttle or in the rain.

*4 : Replace every 2 years, or at indicated odometer intervals, whichever comes first. Replacement requires mechanical skill.

*5 : 50 STATE (meets California)

Maintenance Fundamentals

Periodic Checks

You should also perform other periodic maintenance checks at least once a month regardless of how often you ride, or more often if you ride frequently.

Also, check the odometer reading against the Maintenance Schedule and perform all maintenance that is due. ➤ [P. 34](#)

Tires and wheels	Check the air pressure (➤ P. 44), examine tread for wear and damage (➤ P. 44), and check the wheels for damage.
Fluid levels	Check the engine oil level (➤ P. 57), engine coolant level (➤ P. 61), and brake fluid level (➤ P. 63), final drive oil level (➤ P. 69).
Lights	Check that the headlight, brake light, taillight, turn signals and license plate light are working properly.
Controls	Check the freeplay of the clutch lever (➤ P. 65) and throttle grip (➤ P. 73).
Fuses	Check that you have a full supply of spare fuses.
Nuts & bolts	Check the major nuts and bolts, and tighten as needed.

Replacing Parts

Always use Honda Genuine Parts or their equivalents to ensure reliability and safety. When ordering colored components, specify the model name, color, and code mentioned on the color label. The color label is attached to the frame under the seat.

▶ P. 48

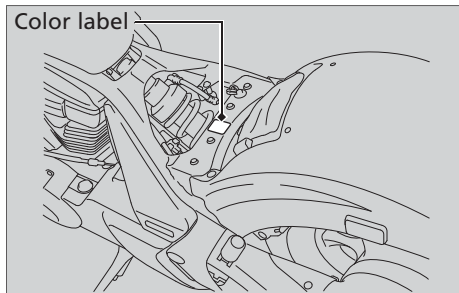

⚠ WARNING

Installing non-Honda parts may make your motorcycle unsafe and cause a crash in which you can be seriously hurt or killed.

Always use Honda Genuine Parts or equivalents that have been designed and approved for your motorcycle.

Battery

Your motorcycle has a maintenance-free type battery. You do not have to check the battery electrolyte level or add distilled water. Clean the battery terminals if they become dirty or corroded.

Do not remove the battery cap seals. There is no need to remove the cap when charging.

What to do in an emergency

If any of the following occur, immediately see your doctor.

- Electrolyte splashes into your eyes:
 - ▶ Wash your eyes repeatedly with cool water for at least 15 minutes. Using water under pressure can damage your eyes.
- Electrolyte splashes onto your skin:
 - ▶ Remove affected clothing and wash your skin thoroughly using water.

- Electrolyte splashes into your mouth:
 - ▶ Rinse mouth thoroughly with water, and do not swallow.

WARNING

The battery gives off explosive hydrogen gas during normal operation. A spark or flame can cause the battery to explode with enough force to kill or seriously hurt you. Wear protective clothing and a face shield, or have a skilled mechanic do the battery servicing.

WARNING: Battery posts, terminals, and related accessories contain lead and lead compounds.

Wash your hands after handling.

Cleaning the Battery Terminals

1. Remove the battery. [P. 52](#)
2. If the terminals are starting to corrode and are coated with a white substance, wash with warm water and wipe clean.
3. If the terminals are heavily corroded, clean the terminals with a wire brush or sandpaper. Wear safety glasses.

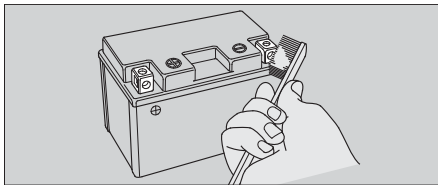

4. After cleaning, reinstall the battery.

The battery has a limited life span. Consult your dealer about when you should replace the battery. Always replace the battery with another maintenance-free battery of the same type.

Charging

If you use electrical accessories that drain the battery or you do not ride frequently, we recommend that you charge the battery every 30 days using a charger designed specifically for your Honda, which can be purchased from your dealer. Read the information that came with your battery charger and follow the instructions on the battery. Avoid using an automobile-type battery charger, as these can overheat a motorcycle battery and cause permanent damage.

Make sure the ignition switch is in the OFF position before charging the battery.

NOTICE

Improper charging can damage the battery. If you can't charge the battery or it appears unable to hold a charge, contact your dealer.

NOTICE

Jump starting using an automobile battery can damage your motorcycle's electrical system and is not recommended. Bump starting is also not recommended.

NOTICE

Installing non-Honda electrical accessories can overload the electrical system, discharging the battery and possibly damaging the system.

Fuses

Fuses protect the electrical circuits on your motorcycle. If something electrical on your motorcycle stops working, check for and replace any blown fuses. ➤ P. 94

Inspecting and Replacing Fuses

Turn off the ignition switch to remove and inspect fuses. If a fuse is blown, replace with a fuse of the same rating. For fuse ratings, see "Specifications." ➤ P. 119

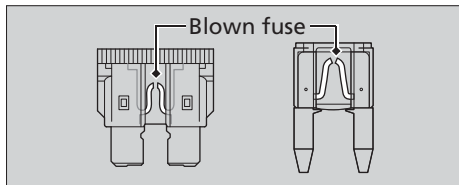
**NOTICE**

Replacing a fuse with one that has a higher rating greatly increases the chance of damage to the electrical system.

If a fuse fails repeatedly, you likely have an electrical fault. Have your motorcycle inspected by your dealer.

Maintenance Fundamentals

Engine Oil

Engine oil consumption varies and oil quality deteriorates according to riding conditions and time elapsed.

Check the engine oil level regularly, and add the recommended engine oil if necessary. Dirty oil or old oil should be changed as soon as possible.

Selecting the Engine Oil

For recommended engine oil, see “Specifications.” [▶ P. 118](#)

If you use non-Honda engine oil, check the label to make sure that the oil satisfies all of the following standards:

- JASO T 903 standard*¹: MA
- SAE standard*²: 10W-30
- API classification*³: SG or higher

- *1. The JASO T 903 standard is an index for engine oils for 4-stroke motorcycle engines. There are two classes: MA and MB. For example, the following label shows the MA classification.

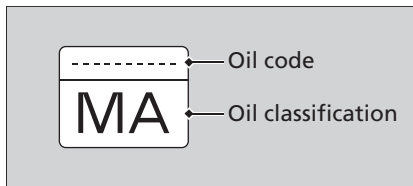

- *2. The SAE standard grades oils by their viscosity.
 *3. The API classification specifies the quality and performance rating of engine oils. Use SG or higher oils, excluding oils marked as “Energy Conserving” on the circular API service symbol.

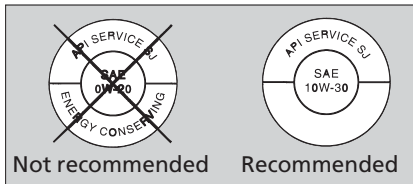

Brake Fluid

Do not add or replace brake fluid, except in an emergency. Use only fresh brake fluid from a sealed container. If you do add fluid, have the brake system serviced by your dealer as soon as possible.

NOTICE

Brake fluid can damage plastic and painted surfaces. Wipe up spills immediately and wash thoroughly.

Recommended brake fluid:

Honda DOT 4 Brake Fluid or equivalent

Final Drive Oil

Recommended final drive oil:

Hypoid gear oil SAE 80

Recommended Coolant

Pro Honda HP is a pre-mixed solution of antifreeze and distilled water.

Concentration:

50% antifreeze and 50% distilled water

A concentration of antifreeze below 40% will not provide proper corrosion and cold temperature protection. A concentration of up to 60% will provide better protection in colder climates.

NOTICE

Using coolant not specified for aluminum engines or using ordinary tap water can cause corrosion.

Air Cleaner

This motorcycle is equipped with a viscous type air cleaner element.

Compressed air cleaning or any other cleaning can degrade the viscous element performance and cause the intake of dust.

Crankcase Breather

Service more frequently when riding in rain, at full throttle, or after the motorcycle is washed or overturned. Service if the deposit level can be seen in the transparent section of the drain tube.

Tires (Inspecting/Replacing)

Checking the Air Pressure

Visually inspect your tires and use an air pressure gauge to measure the air pressure at least once a month or any time you think the tires look low. Always check air pressure when your tires are cold.

Inspecting for Damage

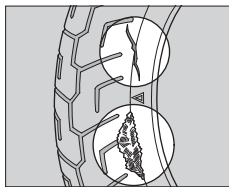

Inspect the tires for cuts, slits, or cracks that exposes fabric or cords, or nails or other foreign objects embedded in the side of the tire or the tread. Also inspect

for the bumps or bulges in the side walls of the tires.

Inspecting for Abnormal Wear

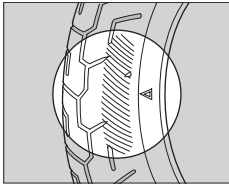

Inspect the tires for signs of abnormal wear on the contact surface.

Inspecting Tread Depth

Inspect the tread wear indicators. If they become visible, replace the tires immediately. For your safety, you should replace the tires when the minimum tread depth is reached.

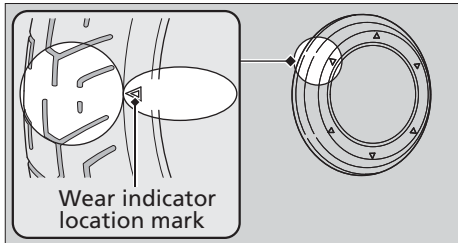

⚠️ WARNING

Riding on tires that are excessively worn or improperly inflated can cause a crash in which you can be seriously hurt or killed.

Follow all instructions in this owner's manual regarding tire inflation and maintenance.

Maintenance Fundamentals

Have your tires replaced by your dealer. For recommended tires, air pressure and minimum tread depth, see “Specifications.”

➤ P. 118

Follow these guidelines whenever you replace tires.

- Use the recommended tires or equivalents of the same size, construction, speed rating, and load range.
- Have the wheel balanced with Honda Genuine balance weights or equivalent after the tire is installed.
- Do not install a tube inside a tubeless tire on this motorcycle. Excessive heat build-up can cause the tube to burst.
- Use only tubeless tires on this motorcycle. The rims are designed for tubeless tires, and during hard acceleration or braking, a tube-type tire could slip on the rim and cause the tire to rapidly deflate.

WARNING

Installing improper tires on your motorcycle can adversely affect handling and stability, and can cause a crash in which you can be seriously hurt or killed.

Always use the size and type of tires recommended in this owner's manual.

Tire Service Life

The service life of your tires is dependent on many factors, including, but not limited to, riding habits, road conditions, vehicle loading, tire air pressure, maintenance history, speed, and environmental conditions (even when the tires are not in use).

In addition to your regular inspections and maintenance, it is recommended that you have annual inspections performed once the tires reach 5 years old. It is also recommended that all tires be removed from service after 10 years from the date of manufacture, regardless of their condition or state of wear.

The last four digits of the TIN (tire identification number) indicate the date of manufacture.

Tire Identification Number (TIN)

The tire identification number (TIN) is a group of numbers and letters located on the sidewall of the tire.

① ② ③

DOT XXXX XXXX 22 09

DOT: This indicates that the tire meets all requirements of the U.S. Department of Transportation.

- ① XXXX: Factory code
- ② XXXX: Tire type code
- ③ 22 09: Date of manufacture (week & year).
Example: week 22 in year 09.

Tire Labeling Example

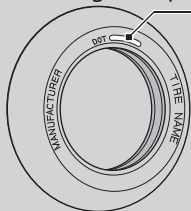

Tire identification number (TIN)

Seat

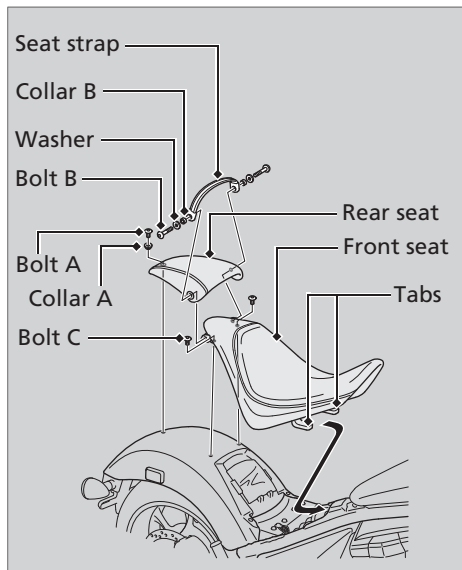

Removal

1. Remove the seat mounting bolt A and collar A.
2. Remove the seat strap by removing the seat mounting bolts B, washers and collars B.
3. Remove the rear seat.
4. Remove the seat mounting bolts C.
5. Pull the front seat back and up.

Installation

1. Insert the tabs into the recess under the frame.
2. Install and tighten the seat mounting bolts C.
3. Install the rear seat.
4. Install the seat mounting bolts B and seat strap. Tighten the seat mounting bolts B.

Torque: 16 lbf·ft (22 N·m, 2.2 kgf·m).

5. Install the seat mounting bolt A and collar.
6. Tighten the seat mounting bolts securely.
 - Be careful not to scratch the rear fender during seat installation or removal.
 - Be careful not to get the seat caught between the stay and bolts while installing the seat.

Side Cover

The right side cover must be removed for the fuse maintenance and to access the owner's manual.

The left side cover must be removed for the main fuse and battery maintenance.

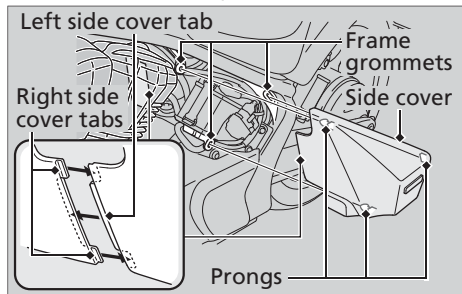

The right and left side covers can be removed in the same way.

Removal

1. Carefully pull the side cover out until the prongs are clear of the frame grommets.
2. Remove the side cover.

Installation

1. Align the left side cover tab with the right side cover tabs.
2. Position the side cover so the prongs are aligned with the frame grommets.
3. Push the prongs in.

Clip

The clip must be removed to remove the ignition switch cover.

Removal

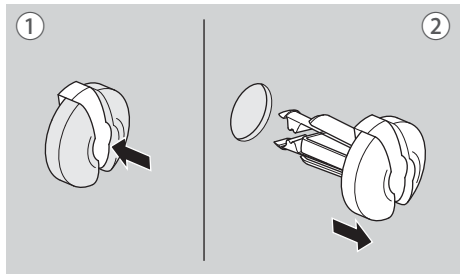

1. Press down on the center pin to release the lock.
2. Pull the clip out of the hole.

Installation

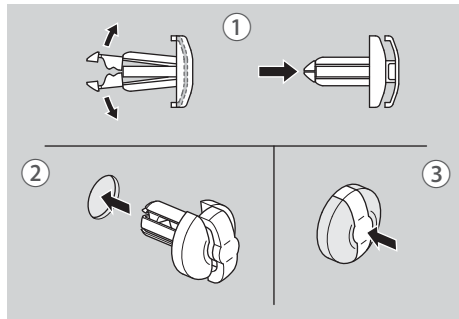

1. Slightly open the retaining pawls and then push them out.
2. Insert the clip into the hole.
3. Press down on the center pin to lock the clip.

Battery

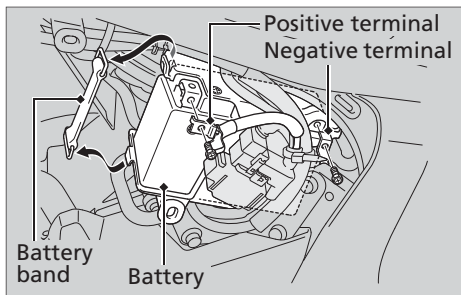

Removal

Make sure the ignition switch is off.

1. Remove the left side cover. [► P. 50](#)
2. Remove the battery band.
3. Disconnect the negative \ominus terminal and remove the battery lead.
4. Disconnect the positive \oplus terminal and remove the battery lead.
5. Remove the battery taking care not to drop the terminal nuts.

Installation

Install the parts in the reverse order of removal. Always connect the positive \oplus terminal first. Make sure that bolts and nuts are tight.

The clock will be reset 0:00 if the battery is disconnected.

For proper handling of the battery, see “Maintenance Fundamentals.” [► P. 39](#)

Battery Goes Dead [► P. 90](#)

Checking Spark Plug

For the recommended spark plug, see "Specifications." ➤ P. 118

Use only the recommended type of spark plug in the recommended heat range.

NOTICE

Using spark plugs an improper heat range can cause engine damage.

1. Carefully pull the rear over head covers on both sides out until the prongs are clear of the engine grommets.

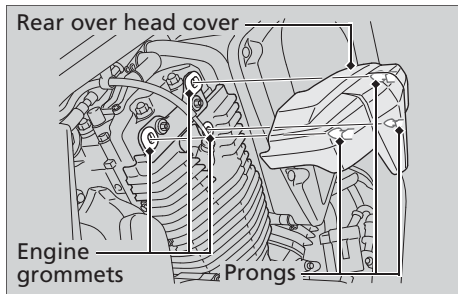

Spark Plug ► Checking Spark Plug

2. Remove the caps, bolts and washers.
3. Carefully pull the front over head covers on both sides out until the prongs are clear of the engine grommets.
4. Remove the front over head center cover.

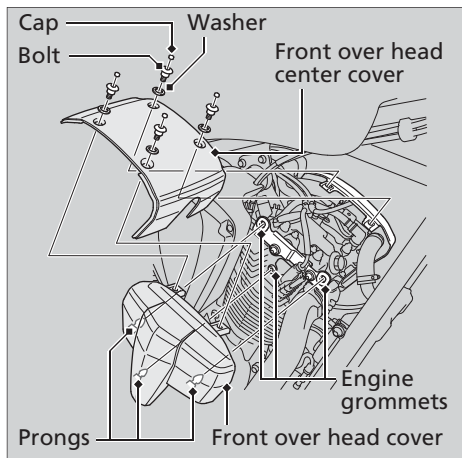

5. Disconnect the spark plug cap.
6. Clean any dirt from around the spark plug base.
7. Remove the spark plug using a spark plug wrench provided in the tool kit.

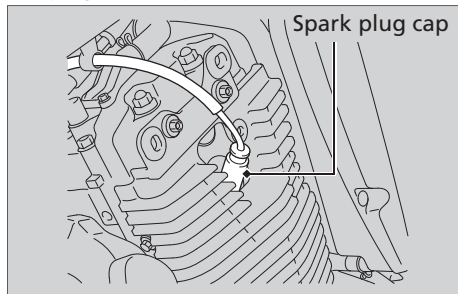

8. Inspect the electrodes and center porcelain for deposits, erosion or carbon fouling.
 - If the erosion or deposit is heavy, replace the plug.
 - Clean a carbon or wet-fouled plug with a plug cleaner, otherwise use a wire brush.

9. Check the spark plug gap using a wire-type feeler gauge.
 - If adjustment is necessary, bend the side electrode carefully.

The gap should be:

0.031 to 0.035 in (0.80 to 0.90 mm)

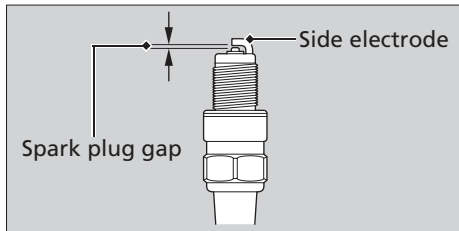

10. Make sure the plug washer is in good condition.
11. With the plug washer attached, thread the spark plug in by hand to prevent cross-threading.

12. Tighten the spark plug:
 - If the old plug is good:
 - 1/8 turn after it seats
 - If installing a new plug, tighten it twice to prevent loosening:
 - a) First, tighten the plug:
 - NGK: 3/4 turn after it seats.
 - DENSO: 1/2 turn after it seats.
 - b) Then loosen the plug.
 - c) Next, tighten the plug again:
 - 1/8 turn after it seats.

NOTICE

Improperly tightened spark plugs can damage the engine. If a plug is too loose, a piston may be damaged. If a plug is too tight, the threads may be damaged.

13. Reinstall the spark plug cap. Take care avoid pinching any cables or wires.

14. Install the front over head center cover.
15. Position the front over head covers on both sides so the prongs are aligned with the engine grommets.
16. Push the prongs in.
17. Install the caps, bolts and washers.
18. Position the rear over head covers on both sides so the prongs are aligned with the engine grommets.
19. Push the prongs in.

Checking the Engine Oil

1. If the engine is cold, idle the engine for 3 to 5 minutes.
2. Turn the ignition switch off, stop the engine and wait 2 to 3 minutes.
3. Remove the oil fill cap/dipstick and wipe it clean.
4. Place your motorcycle in an upright position on a firm, level surface.
5. Insert the oil fill cap/dipstick until it seats, but don't screw it in.
Check that the oil level is between the upper and lower level marks in the oil fill cap/dipstick.
6. Securely install the oil fill cap/dipstick.

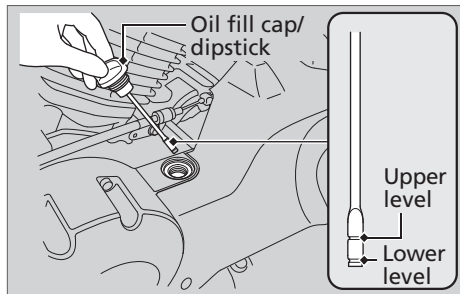

Adding Engine Oil

If the engine oil is below or near the lower level mark, add the recommended engine oil.

► P. 42

1. Remove the oil fill cap/dipstick. Add the recommended oil until it reaches the upper level mark.
 - Place your motorcycle in an upright position on a firm, level surface when checking the oil level.
 - Do not overfill above the upper level mark.
 - Make sure no foreign objects enter the oil filler opening.
 - Wipe up any spills immediately.
2. Securely reinstall the oil fill cap/dipstick.

NOTICE

Overfilling with oil or operating with insufficient oil can cause damage to your engine. Do not mix different brands and grades of oil. They may affect lubrication and clutch operation.

For the recommended oil and oil selection guidelines, see “Maintenance Fundamentals.” ► P. 42

Changing Engine Oil & Filter

Changing the oil and filter requires special tools. We recommend that you have your motorcycle serviced by your dealer.

Use a new Honda Genuine oil filter or equivalent specified for your model.

NOTICE

Using the wrong oil filter can result in serious damage to the engine.

1. If the engine is cold, idle the engine for 3 to 5 minutes.
2. Turn the ignition switch off, stop the engine and wait for 2 to 3 minutes.
3. Park on a firm, level surface and lower the side stand.
4. Place a drain pan under the drain bolt.

5. Remove the oil fill cap/dipstick, drain bolts, and sealing washers to drain the oil.

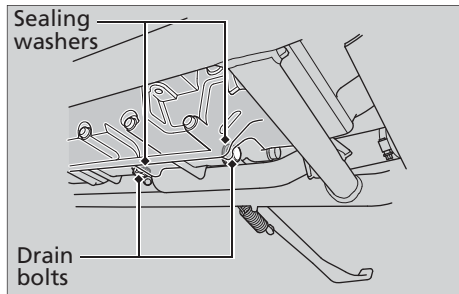

Engine Oil ► Changing Engine Oil & Filter

- Remove the oil filter with a filter wrench and let the remaining oil drain out. Make sure the prior seal is not stuck to the engine.
► Discard the oil and oil filter at an approved recycling center.

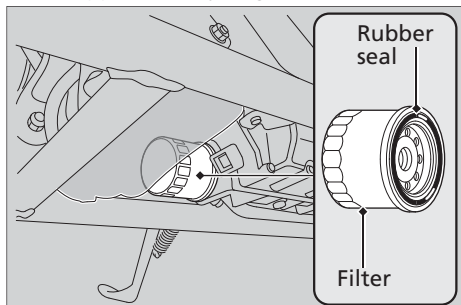

- Apply a thin coat of engine oil to the rubber seal of a new oil filter.
- Install a new oil filter and tighten.

Torque: 19 lbf·ft (26 N·m, 2.7 kgf·m).

- Install the new sealing washers onto the drain bolts. Tighten the drain bolts.

Torque: 22 lbf·ft (30 N·m, 3.1 kgf·m).

- Fill the crankcase with the recommended oil (► P. 42) and install the oil fill cap/dipstick.

Required oil

When changing oil & engine oil filter:

3.9 US qt (3.7 liters)

When changing oil only:

3.7 US qt (3.5 liters)

- Check the oil level. ► P. 57
- Check that there are no oil leaks.

Checking the Coolant

1. Place your motorcycle on a firm, level surface.
2. Check that the coolant level is between the UPPER and LOWER level marks in the reserve tank.

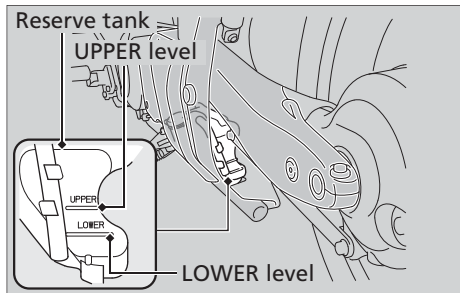

If the coolant level is dropping noticeably or the reserve tank is empty, you likely have a serious leak. Have your motorcycle inspected by your dealer.

Adding Coolant

1. If the coolant level is below the LOWER level, add fluid until the level reaches the UPPER level mark.
Add fluid only from the reserve tank cap and do not remove the radiator cap.

Coolant ► Checking the Coolant

2. Remove the bolt.
3. Carefully pull the left rear cover out until the prongs are clear of the frame grommets.
4. Remove the left rear cover.

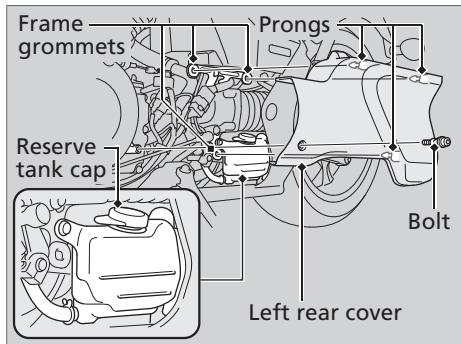

5. Remove the reserve tank cap and add fluid while monitoring the coolant level.
 - Do not overfill above the UPPER level mark.

► Make sure no foreign objects enter the reserve tank opening.

6. Securely reinstall the cap.

⚠ WARNING

Removing the radiator cap while the engine is hot can cause the coolant to spray out, potentially scalding you.

Always let the engine and radiator cool down before removing the radiator cap.

Changing Coolant

Have your dealer change the coolant unless you have the proper tools and are mechanically qualified.

Checking Brake Fluid

1. Place your motorcycle in an upright position on a firm, level surface.
2. **Front** Check that the brake fluid reservoir is horizontal and that the fluid level is above the LOWER level mark.
3. **Rear** Check that the brake fluid reservoir is horizontal and that the level is between the LOWER level and UPPER level marks.

If the brake fluid level in either reservoir is below the LOWER level mark or the brake lever and pedal freeplay becomes excessive, inspect the brake pads for wear. If the brake pads are not worn, you most likely have a leak. Have your motorcycle inspected by your dealer.

Front

Front brake fluid reservoir

LOWER level mark

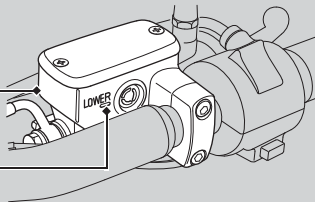

Rear

Rear brake fluid reservoir

UPPER level mark

LOWER level mark

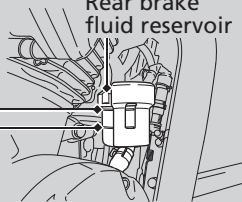

Inspecting the Brake Pads

Check the condition of the brake pad groove wear indicators. The pads need to be replaced if a brake pad is worn to the indicator.

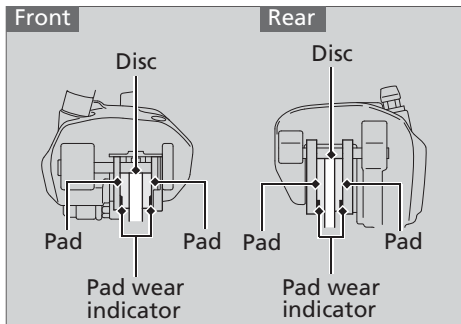

1. **Front** Inspect the brake pads from the bottom of the brake caliper.
2. **Rear** Inspect the brake pads from the rear right of the motorcycle.

If necessary have the pads replaced by your dealer.

Always replace both left and right brake pads at the same time.

Checking the Clutch

Checking the Clutch Lever Freeplay

Check the clutch lever freeplay.

Freeplay at the clutch lever:

3/8 to 13/16 in (10 to 20 mm)

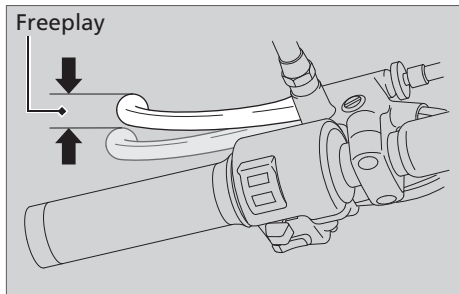

Check the clutch cable for kinks or signs of wear. If necessary have it replaced by your dealer.

Lubricate the clutch cable with a commercially available cable lubricant to prevent premature wear and corrosion.

NOTICE

Improper freeplay adjustment can cause premature clutch wear.

Adjusting the Clutch Lever Freeplay

Upper Adjustment

Attempt adjustment with the upper clutch cable adjuster first.

1. Loosen the upper lock nut.
2. Turn the upper clutch cable adjuster until the freeplay is $\frac{3}{8}$ to $\frac{13}{16}$ in (10 to 20 mm).
3. Tighten the upper lock nut and check the freeplay again.

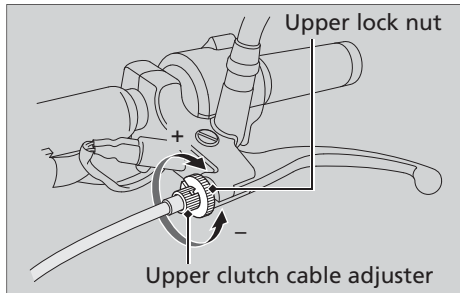

Lower Adjustment

If the upper clutch cable adjuster is threaded out near its limit, or the correct freeplay cannot be obtained, attempt adjustment with the lower adjusting nut.

1. Loosen the upper lock nut and turn the upper clutch cable adjuster all the way in (to provide maximum freeplay). Tighten the upper lock nut.
2. Loosen the lower lock nut.
3. Turn the lower adjusting nut until the clutch lever freeplay is $\frac{3}{8}$ to $\frac{13}{16}$ in (10 to 20 mm).
4. Tighten the lower lock nut and check the clutch lever freeplay.
5. Start the engine, pull the clutch lever in, and shift into gear. Make sure the engine does not stall and the motorcycle does not creep. Gradually release the clutch lever and open the throttle. Your motorcycle should move smoothly and accelerate gradually.

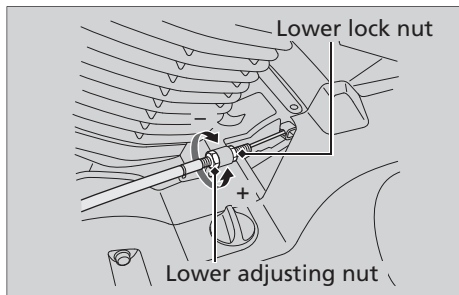

If proper adjustment cannot be obtained or the clutch does not work correctly, see your dealer.

Side Stand

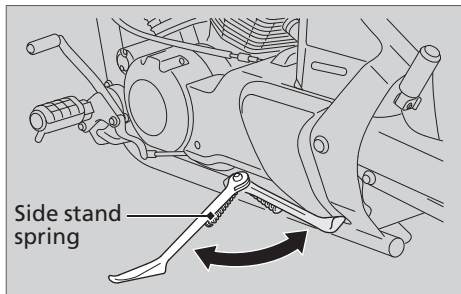

1. Check that the side stand operates smoothly. If the side stand is stiff or squeaky, clean the pivot area and lubricate the pivot bolt with clean grease.
2. Check the spring for damage or loss of tension.
3. Sit on the motorcycle, put the transmission in Neutral, and raise the side stand.
4. Start the engine, pull the clutch lever in, and shift the transmission into gear.
5. Lower the side stand all the way. The engine should stop as you lower the side stand. If the engine doesn't stop, have your motorcycle inspected by your dealer.

Checking the Final Drive Oil

1. Place your motorcycle on the side stand on a level surface.
2. Remove the oil fill hole cap.
3. Check the oil level. It should be flush with the lower edge of the oil fill hole.

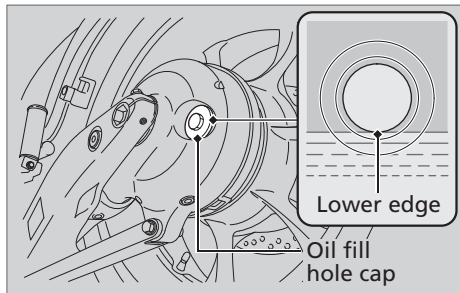

Adding Final Drive Oil

If the final drive oil level is low, check for oil leaks. Add the recommended final drive oil (➤ P. 43) until it reaches the lower edge of the opening.

1. Pour the final drive oil into the oil fill hole until it reaches the lower edge of the opening.
 - ▶ Do not over fill above the lower edge of oil fill hole.
 - ▶ Make sure no foreign objects enter the oil fill hole.
 - ▶ Wipe up any spills immediately.
2. Reinstall the oil fill hole cap and tighten.

Torque: 9 lbf·ft (12 N·m, 1.2 kgf·m).

Changing Final Drive Oil

1. Place your motorcycle on the side stand on a level surface.
2. Place a drain pan under the drain bolt.
3. Remove the oil fill hole cap, drain bolt, and sealing washer to drain the oil.

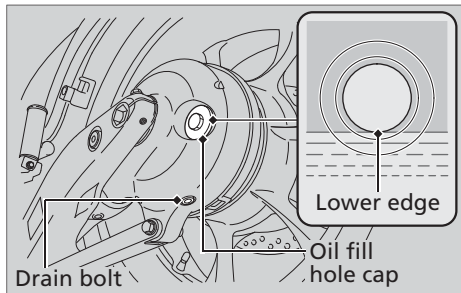

4. Install a new sealing washer onto the drain bolt. Tighten the drain bolt.

Torque: 9 lbf·ft (12 N·m, 1.2 kgf·m).

5. Fill the final gear with the recommended oil. [P. 43](#)

Required oil: 4.4 US oz (130 cm³)

6. Check the oil level. It should be flush with the lower edge of the oil fill hole.
7. Reinstall the oil fill hole cap and tighten.

Torque: 9 lbf·ft (12 N·m, 1.2 kgf·m).

8. Check that there are no oil leaks.

Changing Air Cleaner Element

Use a new Honda Genuine air cleaner element or an equivalent specified for your motorcycle.

NOTICE

Using the wrong air cleaner element can result in serious damage to the engine.

1. Remove the bolts, washers and air cleaner housing cover.
2. Remove the air cleaner element.
3. Thoroughly clean the inside of the air cleaner case.
4. Install the new air cleaner element.
5. Reinstall the air cleaner housing cover, washers and bolts.
6. Tighten the bolts.

Torque: 1.1 lbf·ft (1.5 N·m, 0.2 kgf·m).

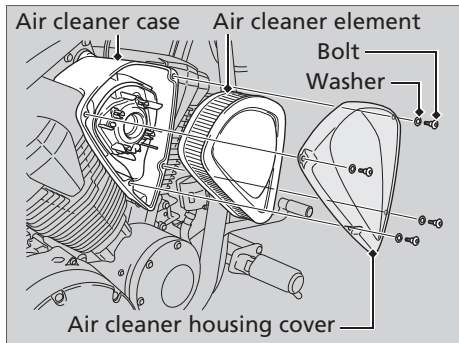

Crankcase Breather

1. Remove the crankcase breather tube and drain deposits.
2. Reinstall the crankcase breather tube.

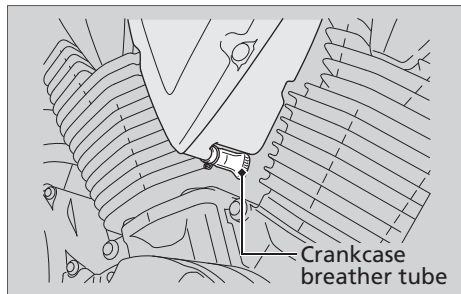

Checking the Throttle

With the engine off, check that the throttle rotates smoothly from fully closed to fully open in all steering positions and throttle freeplay is correct. If the throttle does not move smoothly, close automatically, or if the cable is damaged, have the motorcycle inspected by your dealer.

Freeplay at the throttle grip flange:

1/16 to 1/4 in (2 to 6 mm).

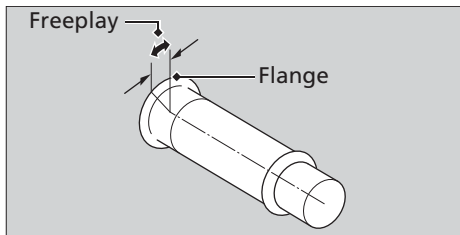

Adjusting the Throttle Freeplay

1. Slide the cable boot.
2. Loosen the lock nut.
3. Turn the adjuster until the freeplay is 1/16 to 1/4 in (2 to 6 mm).
4. Tighten the lock nut, return the cable boot, and inspect the throttle action again.

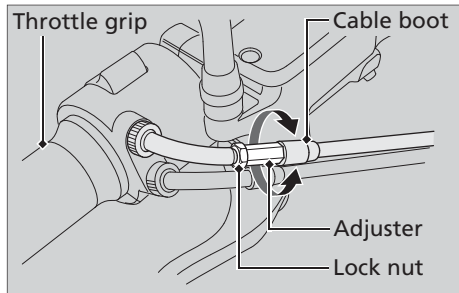

Adjusting the Rear Suspension

Spring Preload

You can adjust the spring preload by the adjuster knob to suit the load or the road surface.

1. Remove the right side cover. ➔ P. 50
2. Turn the adjuster knob clockwise to increase spring preload (hard), or turn counterclockwise to decrease spring preload (soft). The standard position is 6 clicks from the minimum setting.

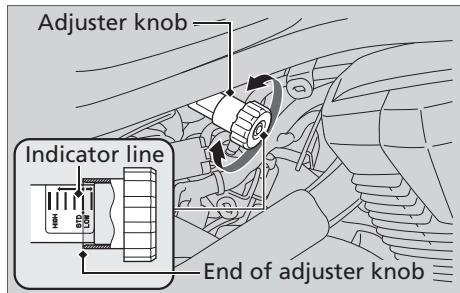

Rebound Damping

You can adjust the rebound damping by the adjuster to suit the load or the road surface. Turn clockwise to increase rebound damping (hard), or turn counterclockwise to decrease rebound damping (soft). The standard position is approximately 3/4 turns from the maximum setting so that the punch mark on the adjuster aligns with the reference punch mark.

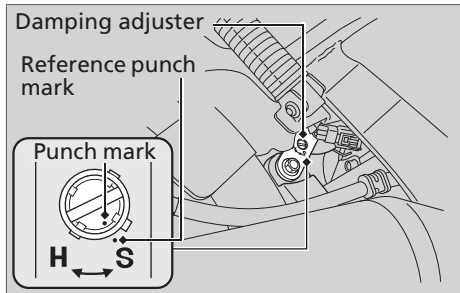

NOTICE

Do not turn the adjuster beyond its limits.

NOTICE

The rear shock absorber damper unit contains high pressure nitrogen gas. Do not attempt to disassemble, service, or improperly dispose of the damper. See your dealer.

Adjusting the Headlight Aim

You can adjust vertical aim of the headlight for proper alignment. To move the headlight case, loosen the bolts and nuts. Tighten the bolts after adjustment.

Torque: 7 lbf·ft (10 N·m, 1.0 kgf·m).

Obey local laws and regulations.

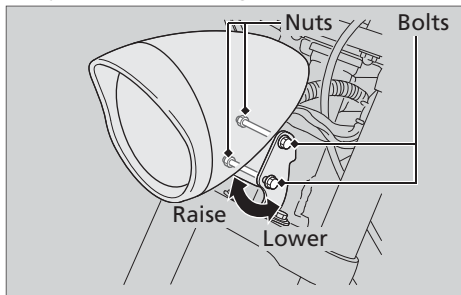

Adjusting the Brake Light Switch

Check the operation of the brake light switch. Turn the adjusting nut in the direction A if the switch operates too late, or turn the nut in the direction B if the switch operates too soon.

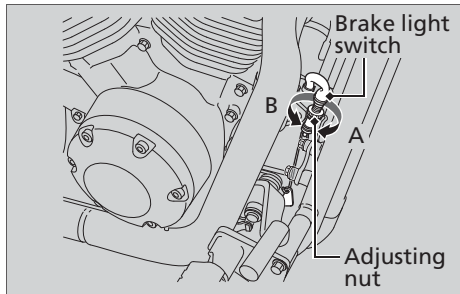

Troubleshooting

Engine Will Not Start	P. 78	Electrical Trouble	P. 90
Overheating (High coolant temperature indicator is on)	P. 79	Battery Goes Dead	P. 90
Warning Indicators On or Flashing	P. 80	Burned-out Light Bulb	P. 90
Low Oil Pressure Indicator	P. 80	Blown Fuse.....	P. 94
PGM-FI (Programmed Fuel Injection)			
Malfunction Indicator Lamp (MIL).....	P. 80		
ABS (Anti-lock Brake System) Indicator			
(VT1300CXA only)	P. 81		
Tire Puncture	P. 82		
Emergency Repair Using a Tire Repair Kit ..	P. 82		
Removing Wheels	P. 82		

Engine Will Not Start

Starter Motor Operates But Engine Does Not Start

Check the following items:

- Check the correct engine starting sequence ➤ [P. 24](#)
- Check that there is gasoline in the fuel tank
- Check if the PGM-FI malfunction indicator lamp (MIL) is on
 - ▶ If the indicator light is on, contact your dealer as soon as possible.

Starter Motor Does Not Operate

Check the following items:

- Make sure engine stop switch is  (Run) position ➤ [P. 22](#)
- Check for a blown fuse ➤ [P. 94](#)
- Check for a loose battery connection or battery terminal corrosion ➤ [P. 40](#)
- Check the condition of the battery ➤ [P. 90](#)

If the problem continues, have your motorcycle inspected by your dealer.

Overheating (High coolant temperature indicator is on)

The engine is overheating when the following occurs:

- High coolant temperature indicator comes on
- Acceleration becomes sluggish

If this occurs, pull safely to the side of the road and perform the following procedure. Extended fast idling may cause the high coolant temperature indicator comes on.

NOTICE

Continuing to ride with an overheated engine can cause serious damage to the engine.

1. Stop the engine using the ignition switch, and then turn the ignition switch to the ON position.

2. Check that the radiator fan is operating, and then turn the ignition switch to the OFF position.

If the fan is not operating:

Suspect a fault. Do not start the engine. Transport your motorcycle to your dealer.

If the fan is operating:

Allow the engine to cool with the ignition switch in the OFF position.

3. After the engine has cooled, inspect the radiator hose and check if there is a leak.

➔ P. 61

If there is a leak:

Do not start the engine. Transport your motorcycle to your dealer.

4. Check the coolant level in the reserve tank, and add coolant as necessary.

➔ P. 61

5. If 1-4 check normal, you may continue riding, but closely monitor the high coolant temperature indicator.

Low Oil Pressure Indicator

If the low oil pressure indicator comes on, pull safely to the side of the road and stop the engine.

NOTICE

Continuing to ride with low oil pressure can cause serious damage to the engine.

1. Check the engine oil level, and add oil as necessary. [▶ P. 57](#)
2. Start the engine.
 - ▶ Only continue riding if the low oil pressure indicator goes off.

Rapid acceleration may momentarily cause the low oil pressure indicator to come on, especially if the oil is at or near the low level. If the low oil pressure indicator stays on when the oil level is at the proper level, stop the engine and contact your dealer.

If the engine oil level goes down rapidly, your motorcycle may have a leak or another serious problem. Have your motorcycle inspected by your dealer.

PGM-FI (Programmed Fuel Injection) Malfunction Indicator Lamp (MIL)

If the indicator comes on while riding, you may have a serious problem with the PGM-FI system. Reduce speed and have your motorcycle inspected by your dealer as soon as possible.

ABS (Anti-lock Brake System) Indicator (VT1300CXA only)

If the indicator operates in one of the following ways, you may have a serious problem with the brake system. Reduce your speed and have your motorcycle inspected by your dealer as soon as possible.

- Indicator comes on or starts flashing while riding
- Indicator does not come on when the ignition switch is in the on position
- Indicator does not go off at speeds above 6 mph (10 km/h)

If the ABS indicator stays on, your brakes will continue to work as a conventional system, but without the anti-locking function.

The ABS indicator may come on if you turn the rear wheel while your motorcycle is lifted off the ground. In this case, turn the ignition switch off and then on again. The ABS indicator will go off after your speed reaches 19 mph (30 km/h).

Tire Puncture

Repairing a puncture or removing a wheel requires special tools and technical expertise. We recommend you have this type of service performed by your dealer.

After an emergency repair, always have the tire inspected/replaced by your dealer.

Emergency Repair Using a Tire Repair Kit

If your tire has a minor puncture, you can make an emergency repair using a tubeless tire repair kit.

Follow the instructions provided with the emergency tire repair kit.

Riding your motorcycle with a temporary tire repair is very risky. Do not exceed 30 mph (50 km/h). Have the tire replaced by your dealer as soon as possible.

WARNING

Riding your motorcycle with a temporary tire repair can be risky. If the temporary repair fails, you can crash and be seriously injured or killed.

If you must ride with a temporary tire repair, ride slowly and carefully and do not exceed 30 mph (50 km/h) until the tire is replaced.

Removing Wheels

Follow these procedures if you need to remove a wheel in order to repair a puncture.

(VT1300CXA only)

When removing and installing the wheel, be careful not to damage the wheel speed sensor and pulser ring.

Front Wheel**Removal**

1. Park on a firm, level surface.
2. Remove the fixing bolts and remove the left brake caliper assembly from the fork leg.
 - Support the brake caliper assembly so that it doesn't hang from the brake hose. Do not twist the brake hose.
 - Avoid getting grease, oil, or dirt on the disc or pad surfaces.
 - Do not pull the brake lever while the brake caliper is removed.
3. Remove the front axle bolt.
4. Loosen the right and left axle pinch bolts.

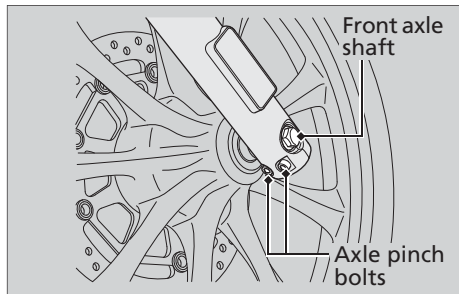
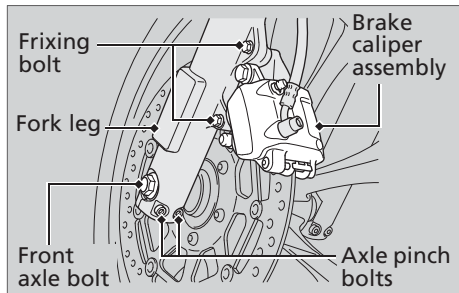

5. Support your motorcycle securely and raise the front wheel off the ground using a maintenance stand or a hoist.
6. Remove the front axle shaft, front wheel and side collars.

Installation

1. Attach the side collars to the wheel.
2. On the right side, place the wheel between the fork legs and insert the front axle shaft, through the right fork leg and wheel hub.
3. Align the index line of the front axle shaft with the recessed surface of the fork leg.

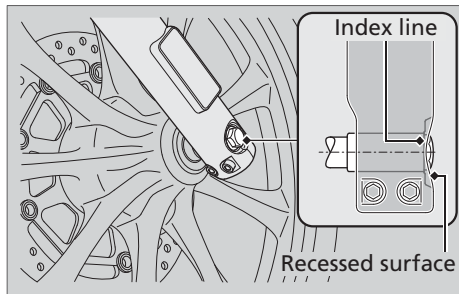

4. Tighten the right axle pinch bolts.

Torque: 16 lbf·ft (22 N·m, 2.2 kgf·m).

5. Tighten the front axle bolt.

Torque: 47 lbf·ft (64 N·m, 6.5 kgf·m).

6. Install the brake caliper and tighten the fixing bolts.

Torque: 23 lbf·ft (31 N·m, 3.2 kgf·m).

NOTICE

When installing the brake caliper into position on the fork leg, carefully fit the brake disc between the pads to avoid scratching them.

7. After installing the wheel, apply the brake lever several times, then check if the wheel rotates freely. Recheck the wheel if the brake drags or if the wheel does not rotate freely.
8. Check the clearances between each surface of the brake disc and the brake bracket (not the brake pads) are symmetrical.
- If the clearances are symmetrical, loosen the right axle pinch bolts and pull the right fork outward or push

inward to adjust the clearance.

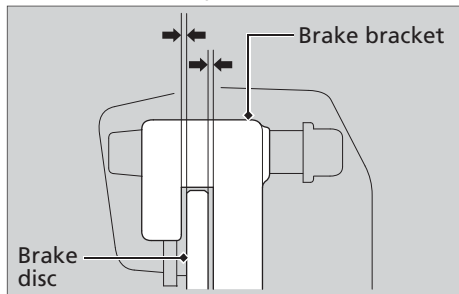

9. Tighten the left axle pinch bolts.

Torque: 16 lbf·ft (22 N·m, 2.2 kgf·m).

If a torque wrench was not used for installation, see your dealer as soon as possible to verify proper assembly.

Rear Wheel

Removal

1. Park on a firm, level surface.
2. Support your motorcycle securely and raise the rear wheel off the ground using a maintenance stand or a hoist.
3. Remove the exhaust pipe joint nuts.

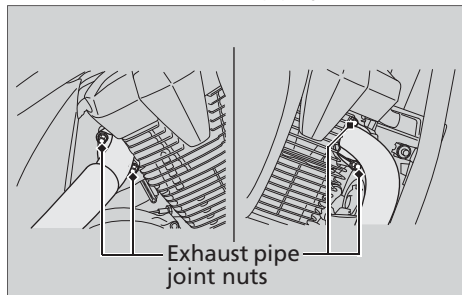

4. Remove the muffler bracket bolt A, B, nuts and washers.
5. Remove the muffler.

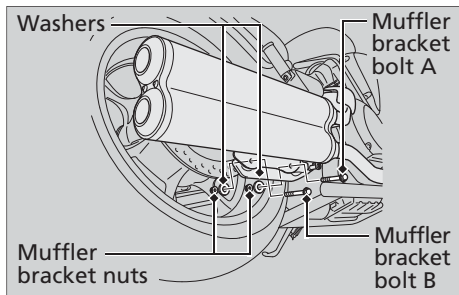

6. Remove the axle holding bolt and washer.
7. While holding the outer end of the rear axle shaft with a wrench, remove the rear axle nut and washer.

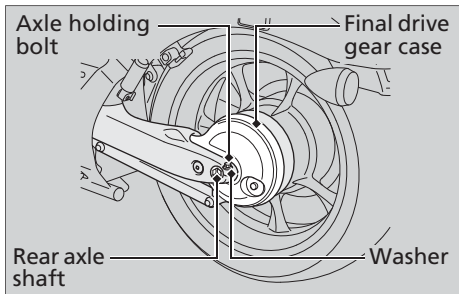

8. Cover the right swingarm with protective tape or an equivalent.
9. Remove the rear brake bracket bolt.
10. Slide the rear axle shaft to the left side until the rear wheel can be removed.
 - Do not pull the rear axle shaft out completely.
11. Remove the rear brake bracket.
12. Move the wheel to the right to separate it from the final drive gear case.

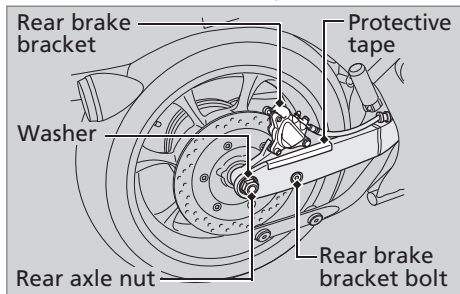

Tire Puncture ► Removing Wheels

13. Remove the wheel and side collar.
 - Support the brake caliper assembly so that it doesn't hang from the brake hose. Do not twist the brake hose.
 - Avoid getting grease, oil, or dirt on the disc or pad surfaces.
 - Do not push the brake pedal while the brake caliper is removed.

Installation

Before installing the wheel, check that the wheel hub and final drive gear splines are coated with molybdenum disulfide paste.

Recommended molybdenum disulfide paste:

(USA only) Pro Honda Moly 60 paste or equivalent

1. Install the side collar and position the wheel between the swingarm and the final drive gear case.
 - Be sure the splines on the wheel hub fit into the final drive gear case.
2. Install the rear brake bracket and rear brake bracket bolt.

NOTICE

When installing the brake caliper into position, carefully fit the brake disc between the pads to avoid scratching them.

3. Push the rear axle shaft from the left side, through the wheel hub and rear brake bracket.
4. Remove the protective tape or an equivalent.
5. Tighten the rear brake bracket bolt.

Torque: 51 lbf·ft (69 N·m, 7.0 kgf·m).

6. Install the rear axle nut and washer.
Tighten the rear axle nut.

Torque: 94 lbf·ft (127 N·m, 13.0 kgf·m).

7. Install the axle holding bolt and washer.
Tighten the axle holding bolt.

Torque: 20 lbf·ft (27 N·m, 2.8 kgf·m).

8. After installing the wheel, apply the brake pedal several times, then check if the wheel rotates freely. Recheck the wheel if the brake drags or if the wheel does not rotate freely.

9. Install the muffler, muffler bracket bolt A, B, nuts and washer.
Tighten the muffler bracket bolt A, B, nuts and exhaust pipe joint nuts.

Exhaust pipe joint nut:

Torque: 17 lbf·ft (23 N·m, 2.3 kgf·m).

Muffler bracket bolt A, B and nuts:

Torque: 20 lbf·ft (27 N·m, 2.8 kgf·m).

If a torque wrench was not used for installation, see your dealer as soon as possible to verify proper assembly.

Battery Goes Dead

Charge the battery using a motorcycle battery charger.

Remove the battery from the motorcycle while charging.

Do not use an automobile-type battery charger, as these can overheat a motorcycle battery and cause permanent damage.

If the battery does not recover after recharging, contact your dealer.

NOTICE

Jump starting using an automobile battery is not recommended, as this can damage your motorcycle's electrical system.

Burned-out Light Bulb

Follow the procedure below to replace a burned-out light bulb.

Turn the ignition switch to the OFF position. Allow the bulb to cool before replacing it. Do not use bulbs other than those specified. Check the replacement bulb for correct operation before riding.

For the light bulb wattage, see "Specifications." [▶ P. 119](#)

Headlight Bulb

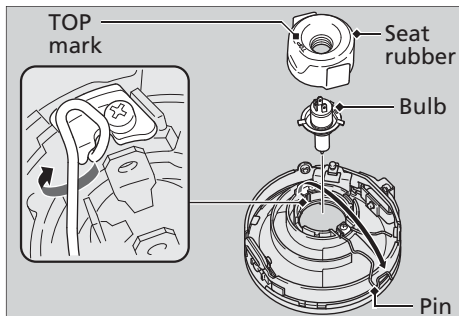
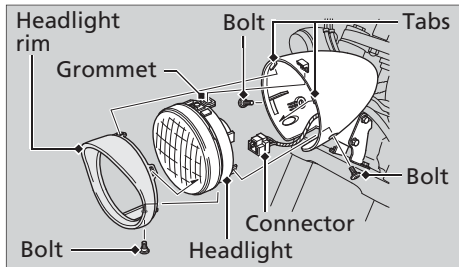

1. Remove the bolts from the headlight case.
2. Remove the headlight rim by pulling its lower end forward and release the tabs.
3. Remove the headlight by pulling it forward and release the grommet.
4. Disconnect the connector.
5. Remove the seat rubber.
6. Unhook the pin and remove the bulb.
7. Install a new bulb and parts in the reverse order of removal.
 - Install the seat rubber with its TOP mark facing up.

Do not touch the glass surface with your fingers. If you touch the bulb with your bare hands, clean it with a cloth moistened with alcohol.

Brake/Taillight Bulb

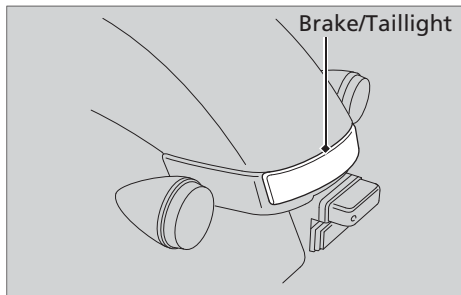

The brake and tail light uses several LEDs. If there is a LED which is not turned on, see your dealer for this service.

Front/Rear Turn Signal Bulb

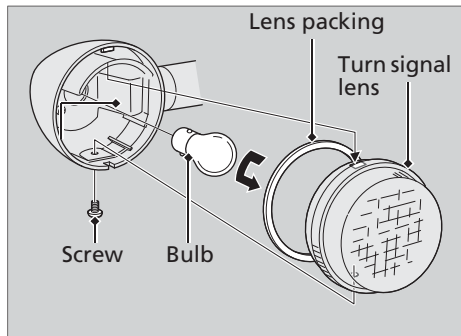

1. Remove the turn signal lens and lens packing by removing the screw.
2. Slightly press the bulb and turn it counterclockwise.
3. Install a new bulb in the reverse order of removal.

License Plate Light Bulb

1. Remove the screws and license light cover.
2. Pull the bulb out of the socket without turning it.
3. Install a new bulb and parts in the reverse order of removal.

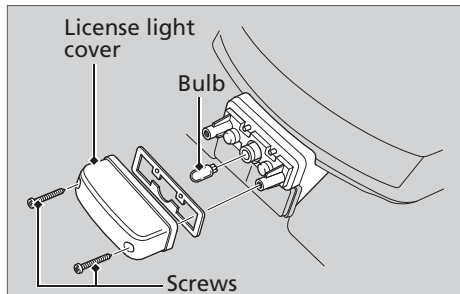

Blown Fuse

Before handling fuses, see “Inspecting and Replacing Fuses.” [► P. 41](#)

Fuse Box Fuses

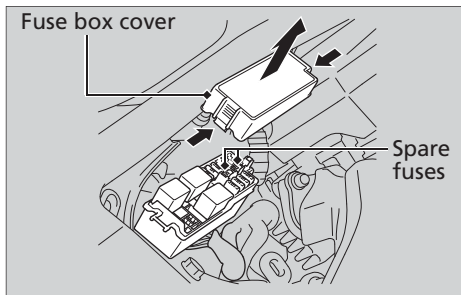

1. Remove the right side cover. [► P. 50](#)
2. Remove the fuse box cover.
3. Pull the fuses out one by one check for a blown fuse. Always replace a blown fuse with a spare of the same rating.
4. Reinstall the fuse box cover.
5. Reinstall the right side cover.

NOTICE

If a fuse fails repeatedly, you likely have an electrical problem. Have your motorcycle inspected by your dealer.

I Main Fuse

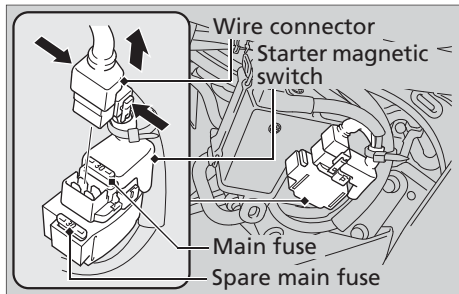

1. Remove the left side cover. ► P. 50
2. Disconnect the wire connector of the starter magnetic switch.
3. Pull the main fuses out and check for a blown fuse. Always replace a blown fuse with a spare of the same rating.
 - Spare main fuse is located near the starter magnetic switch.
4. Reinstall parts in the reverse order of removal.

Information

Keys	P. 97
Instruments, Controls, & Other Features	P. 98
Caring for Your Motorcycle	P. 99
Storing Your Motorcycle	P. 101
Transporting Your Motorcycle	P. 102
You & the Environment	P. 103
Vehicle Identification Number	P. 104
Emission Control Systems	P. 105
Catalytic Converter	P. 110
Oxygenated Fuels	P. 111
Authorized Manuals	P. 112
Warranty Coverage and Service	P. 113

Honda Contacts	P. 114
USA Reporting Safety Defects	P. 116

Keys

Ignition key/Steering Lock Key

Be sure to record the key number provided with the original keys and record it in this manual.

Store the spare key in a safe location.

To make a duplicate, take the spare key or the key number to a locksmith.

If you lose all ignition keys and the key number, the ignition switch assembly will probably have to be removed by your dealer to determine the key number.

A metal key holder may cause damage to the area surrounding the ignition switch.

Instruments, Controls, & Other Features

Ignition Switch

The headlight is always on when the ignition switch is on. Leaving the ignition switch on with the engine stopped will drain the battery.

Do not turn the key while riding.

Engine Stop Switch

Do not use the engine stop switch except in an emergency. Doing so when riding will cause the engine to suddenly turn off, making riding unsafe.

If you stop the engine using the engine stop switch, turn the ignition switch off. Failing to do so will drain the battery.

Odometer

The display locks at 999,999 when the readout exceeds 999,999.

Tripmeter

The tripmeter returns to 0.0 when the read-out exceeds 999.9.

Document Bag

The owner's manual can be stored in the plastic document bag located inside of the right side cover. The registration, and insurance information can be stored in the plastic document bag located under the seat.

Ignition Cut-off System

A banking (lean angle) sensor automatically stops the engine and fuel pump if the motorcycle falls over. To reset the sensor, you must turn the ignition switch to OFF and back to the ON position before the engine can be restarted.

Caring for Your Motorcycle

Frequent cleaning and polishing is important to ensure the life of your Honda. A clean motorcycle makes it easier to spot potential problems.

In particular, seawater and salts used to prevent ice on roads promote the formation of corrosion. Always wash your motorcycle thoroughly after riding on coastal or treated roads.

Washing

Allow the engine, muffler, brakes, and other high-temperature parts to cool before washing.

1. Rinse your motorcycle thoroughly using a garden hose to remove loose dirt.
2. If necessary, use a sponge or a soft towel with mild cleaner to remove road grime.
 - ▶ Clean the headlight lens, panels, and other plastic components with extra care to avoid scratching them.

Avoid directing water into the air cleaner, muffler, and electrical parts.

3. Thoroughly rinse your motorcycle with plenty of clean water and dry with a soft, clean cloth.
4. After the motorcycle dries, lubricate any moving parts.
 - ▶ Make sure that no lubricant spills onto the brakes or tires. Brake discs, pads, drum or shoes contaminated with oil will suffer greatly reduced braking effectiveness and can lead to a crash.
5. Apply a coat of wax to prevent corrosion.
 - ▶ Avoid products that contain harsh detergents or chemical solvents. These can damage the metal, paint, and plastic on your motorcycle.Keep the wax clear of the tires and brakes.

Washing Precautions

Follow these guidelines when washing:

- Do not use high-pressure washers:
 - ▶ High-pressure water cleaners can damage moving parts and electrical parts, rendering them inoperable.
- Do not direct water at the muffler:
 - ▶ Water in the muffler can prevent starting and causes rust in the muffler.
- Dry the brakes:
 - ▶ Water adversely affects braking effectiveness. After washing, apply the brakes intermittently at low speed to help dry them.
- Do not direct water inside the right side cover and under the seat:
 - ▶ Water in the inside side cover and under seat compartment can damage your documents and other belongings.
- Do not direct water at the air cleaner:
 - ▶ Water in the air cleaner can prevent the engine from starting.

- Do not direct water near the headlight:
 - ▶ Any condensation inside the headlight should dissipate after a few minutes of running the engine.

Aluminum Components

Aluminum will corrode from contact with dirt, mud, or road salt. Clean aluminum parts regularly and follow these guidelines to avoid scratches:

- Do not use stiff brushes, steel wool, or cleaners containing abrasives.
- Avoid riding over or scraping against curbs.

Panels

Follow these guidelines to prevent scratches and blemishes:

- Wash gently using a soft sponge and plenty of water.
- To remove stubborn stains, use diluted detergent and rinse thoroughly with plenty of water.

- Avoid getting gasoline, brake fluid, or detergents on the instruments, panels, or headlight.

Exhaust Pipe and Muffler

The exhaust is made of stainless steel, which can become tarnished with burn marks if splattered with oil or other substances when hot. To remove burn marks, use a mild abrasive compound. To remove dirt and mud, use a kitchen cleaning solution for stainless steel and wash with a soft sponge. Rinse with plenty of water to remove all residue.

NOTICE

Even though the exhaust is made of stainless steel, it can become stained. Remove all marks and blemishes as soon as they are noticed.

Storing Your Motorcycle

If you store your motorcycle outdoors, you should consider using a full-body motorcycle cover.

If you won't be riding for an extended period, follow these guidelines:

- Wash your motorcycle and wax all painted surfaces (except matte painted surfaces). Coat chrome pieces with rust-inhibiting oil.
- Place your motorcycle on a maintenance stand and position a block so that both tires are off the ground.
- After rain, remove the body cover and allow the motorcycle to dry.
- Remove the battery to prevent discharge. Charge the battery in a shaded, well-ventilated area.
 - ▶ If you leave the battery in place, disconnect the negative ⊖ terminal to prevent discharge.

Transporting Your Motorcycle

After removing your motorcycle from storage, inspect all maintenance items required by the Maintenance Schedule.

USA For more information about storage, refer to the Honda Winter Storage Guide, available from your dealer.

Transporting Your Motorcycle

If your motorcycle needs to be transported, it should be carried on a motorcycle trailer or a flatbed truck or trailer that has a loading ramp or lifting platform, and motorcycle tie-down straps. Never try to tow your motorcycle with a wheel or wheels on the ground.

NOTICE

Towing your motorcycle can cause serious damage to the transmission.

You & the Environment

Owning and riding a motorcycle can be enjoyable, but you must do your part to protect the environment.

Choose Sensible Cleaners

Use a biodegradable detergent when you wash your motorcycle. Avoid aerosol spray cleaners that contain chlorofluorocarbons (CFCs) which damage the atmosphere's protective ozone layer.

Recycle Wastes

Put oil and other toxic wastes in approved containers and take them to a recycling center. Call your local or state office of public works or environmental services to find a recycling center in your area, and to get instructions on how to dispose of non-recyclable wastes. Do not place used engine oil in the trash, or pour it down a

drain or on the ground. Used oil, gasoline, coolant, and cleaning solvents contain poisons that can hurt refuse workers and contaminate drinking water, lakes, rivers, and oceans.

Vehicle Identification Number

The VIN and engine serial numbers uniquely identify your motorcycle and are required in order to register your motorcycle. They may also be required when ordering replacement parts. The VIN number is stamped on the right side of the steering head and also appears on the Safety Certification Label attached to the left side of the frame.

The engine number is stamped on the top of the crankcase.

You should record these numbers and keep them in a safe place.

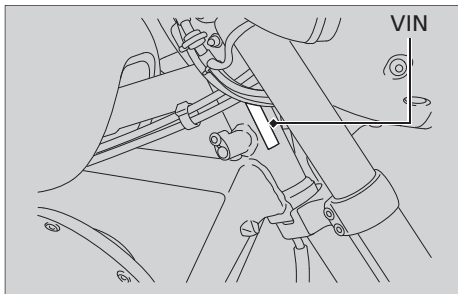
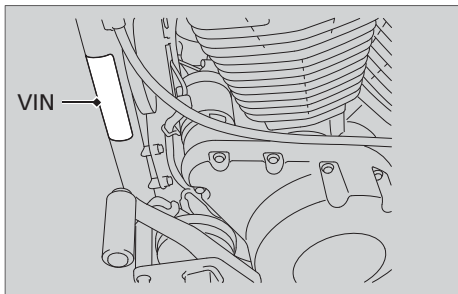

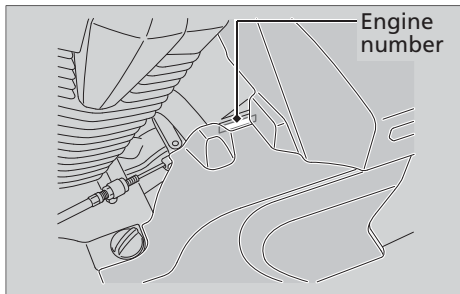

Emission Control Systems

Your motorcycle engine emits combustion byproducts, including carbon monoxide (CO), oxides of nitrogen (NOx), and hydrocarbons (HC). Gasoline evaporation also emits hydrocarbons. Controlling the production of NOx, CO, and HC is important for the environment.

Exhaust Emission Requirements

The U.S. Environmental Protection Agency (EPA), the California Air Resources Board (CARB), and Environment Canada (EC) require that your motorcycle comply with applicable exhaust, crankcase, and fuel permeation emission standards during its useful life, when operated and maintained according to the instructions provided.

CARB also requires that your motorcycle comply with applicable evaporative emission requirements during its useful life, when operated and maintained according to the instructions provided.

Compliance with the terms of the Distributor's Warranties for Honda Motorcycle Emission Control Systems is necessary in order to maintain a valid emissions system warranty (USA only). The Vehicle Emission Control Information label is attached to the left side of the frame.

Vehicle emission control information label

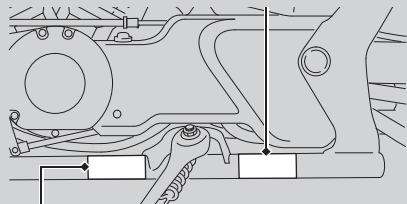

Vehicle emission control information label

Canada only

Noise Emission Requirements

The EPA requires that motorcycles built after January 1, 1983 comply with applicable noise emission standards for one year or 3,730 miles (6,000 km) after the time of purchase when operated and maintained according to the instructions provided.

Exhaust Emission Control System

The exhaust emission control system includes the following components that should not need adjustment, although periodic inspection by your Honda dealer is recommended.

PGM-FI System

The PGM-FI (programmed fuel injection) system uses sequential multiport fuel injection, and is comprised of air intake, engine control, fuel control, and exhaust control subsystems. The engine control module (ECM) uses sensors to determine how much air enters the engine, and then controls how much fuel to inject.

Ignition Timing Control System

The ignition timing control system adjusts the ignition timing to reduce the amount of HC, CO, and NO_x produced.

Secondary Air Injection System

The secondary air injection system adds filtered air into the exhaust gas to help improve emission control performance.

Catalytic Converters

The exhaust system contains one or more catalytic converters. Catalytic converters use a catalyst to convert most of the harmful exhaust gas compounds into harmless compounds.

Evaporative Emission Control System

50 STATE (meets California)

An evaporative emissions control system uses a canister filled with charcoal to absorb fuel vapor from the fuel tank while the engine is off. The vapor is drawn into the engine and burned while riding.

Crankcase Emissions Control System

The positive crankcase ventilation system prevents gases that build up in the engine's crankcase from being released into the atmosphere. The gases are drawn into the engine and burned while riding.

Fuel Permeation Emission Control

The fuel tank, fuel hoses, and fuel vapor charge hoses use fuel permeation control technologies to prevent fuel vapor emissions.

Tampering with these components to reduce or defeat the effectiveness of the fuel permeation technologies is prohibited.

Noise Emission Control System

TAMPERING WITH THE NOISE CONTROL SYSTEM IS PROHIBITED:

U. S. federal law prohibits, and Canadian provincial laws may prohibit, the following acts or the causing thereof: (1) The removal or rendering inoperative by any person, other than for purposes of maintenance, repair or replacement, of any device or element of design incorporated into any new vehicle for the purpose of noise control prior to its sale or delivery to the ultimate purchaser or while it is in use; or (2) the use of the vehicle after such device or element of design has been removed or rendered inoperative by any person.

AMONG THOSE ACTS PRESUMED TO CONSTITUTE TAMPERING ARE THE FOLLOWING ACTS:

1. Removal of, or puncturing the muffler, baffles, header pipes or any other component which conducts exhaust gases.
2. Removal of, or puncturing of any part of the intake system.
3. Lack of proper maintenance.
4. Replacing any moving parts of the vehicle, or parts of the exhaust or intake system, with parts other than those specified by the manufacturer.

Problems Affecting Motorcycle Exhaust Emissions

Have your motorcycle inspected and repaired by your Honda dealer if you experience any of the following symptoms:

- Hard starting or stalling after starting
- Rough idling
- Misfiring or backfiring during acceleration
- Poor engine performance and poor fuel economy

Catalytic Converter

This motorcycle is equipped with two oxidation catalytic converters. Each catalytic converter contains precious metals that serve as catalysts in high temperature chemical reactions that convert hydrocarbons (HC) and carbon monoxide (CO) in the exhaust gasses into safe compounds.

A defective catalytic converter contributes to air pollution and can impair your engine's performance. A replacement unit must be an original Honda part or equivalent.

Follow these guidelines to protect your motorcycle's catalytic converter.

- Always use unleaded gasoline. Leaded gasoline will damage the catalytic converter.
- Keep the engine in good running condition. A poorly running engine can cause the catalytic converter to overheat causing damage to the converter or the motorcycle.
- If your engine is misfiring, backfiring, stalling, or otherwise not running properly, stop riding and turn off the engine. Have your motorcycle serviced as soon as possible.

Oxygenated Fuels

Some conventional fuels blended with alcohol or an ether compound are available in some locales to help reduce emissions to meet clean air standards. These gasolines are collectively referred to as oxygenated fuels. If you plan to use oxygenated fuel, check that it is unleaded and meets the minimum octane rating and blend requirement.

The following fuel blends are EPA-approved and have been approved for use in your motorcycle:

- Ethanol (ethyl alcohol) 10% by volume (max). Gasoline containing ethanol may be marketed under the name "Gasohol."
- MTBE (Methyl Tertiary Butyl Ether) 15% by volume (max)
- Methanol (methyl alcohol) 5% by volume (max) that contain cosolvents and corrosion inhibitors to protect the fuel system. Never use a blend containing more than 5%.

If you accidentally fill your fuel tank with an oxygenated fuel containing higher percentages, you may experience performance problems. To resolve the problem, have your dealer drain the fuel tank and replace with the correct fuel. Fuel system or performance problems resulting from the use of an oxygenated fuel containing higher percentages are not covered by your warranty.

NOTICE

Improper use of oxygenated fuels can damage metal, rubber, and plastic parts of your fuel system.

Oxygenated fuel can also damage paint. Damage caused by spilled fuel is not covered by warranty.

If you notice any undesirable operating symptoms or performance problems, try a different brand of gasoline.

Authorized Manuals

The Service Manual used by your authorized Honda dealer is available from your Honda dealer or Helm, Inc.

(USA only, Canada: See your Honda dealer to order authorized manuals.)

Also available, but not necessary to service your model, is the Honda Common Service Manual, which explains basic service information for various systems on Honda motorcycles, motor scooters, and all-terrain vehicles.

These Honda manuals are written for the professional technician. However, if you possess the proper tools, observe the safety standards, and are mechanically capable, you should find them easy to use.

Special Honda tools are necessary for some procedures.

Order On-Line: www.helminc.com

Order Toll Free: 1-888-CYCLE93

(1-888-292-5393)

(NOTE: For Credit Card Orders Only)

Monday – Friday 8:00 AM – 6:00 PM EST

Publication Item No.	Description
61MFR05	2012 VT1300CR/CRA/CT/CTA/CS/CSA/CX/CXA Service Manual
61CM002	Common Service Manual
31MFR620	2012 VT1300CX/CXA Owner's Manual

Warranty Coverage and Service

Coverage

Your new Honda is covered by the following warranties:

- Motorcycle Limited Warranty
- Emission Control System Warranty
- Noise Control Warranty

The responsibilities, restrictions, and exclusions that apply to these warranties are explained in the Warranties Booklet given to you by your Honda dealer at the time of purchase. Always keep your Honda owner's card with your Warranties Booklet.

Canada Please refer to the Warranty Booklet posted on our web site at www.honda.ca.

It is important to realize that your warranty

applies only to defects in material or workmanship of your Honda. Your warranty coverage does not apply to the normal wear and deterioration associated with use of the motorcycle.

Your warranty coverage is not voided if you perform your own maintenance. However, failures that occur due directly to improper maintenance are not covered by these warranties.

You can extend almost all of your warranty coverage through the Honda Protection Plan (USA only). For more information, see your Honda dealer.

Service

Please remember that maintenance recommended in the Maintenance Schedule is not included in your warranty coverage.

Honda Contacts

If you believe you have a problem with your motorcycle, call the service department of your Honda dealer. Make an appointment for an inspection and diagnosis. You will be asked to authorize that inspection, and your dealer will return the results of the inspection. If a problem exists and is covered under warranty, your dealer will perform the warranty repairs.

If you have any questions about your warranty coverage or the nature of the repair, talk to the Service Manager of your Honda dealer.

If a misunderstanding occurs and you aren't satisfied with your dealer's handling of the situation, we suggest you discuss your problem with the appropriate member of the dealership's management team. If you are still not satisfied, contact the owner of the dealership or their designated representative.

Honda Contacts

American Honda Motor Co., Inc.

If you wish to contact Honda directly to comment on your experiences with your motorcycle or with your dealer, please send your comments to the following address:

Motorcycle Division,
American Honda Motor Co., Inc.,
P.O. Box 2200, Torrance,
CA 90509-2200
Mailstop: 100-4C-7B,
Telephone: (866) 784-1870.

Canada Honda Canada Inc., Customer Relation Dept, 180 Honda Boulevard, Markham, Ontario L6C 0H9, telephone: (888) 946-6329, facsimile: (877) 939-0909

Please include the following information in your letter:

- Name, address, and telephone number

- Product model, year, and VIN
- Date of purchase
- Dealer name and address

We will likely ask your Honda dealer to respond, or possibly acknowledge your comments directly.

Your Honda Dealer

The service department of your Honda dealer offers trained personnel to perform regular maintenance and most repairs. It has the latest available service information from Honda and also handles warranty inspections and repairs.

The parts department offers Honda Genuine Parts, Pro Honda products, Honda Genuine Accessories (USA only), and Honda accessories and products (Canada only) that provide the same quality that went into your motorcycle.

The sales department offers the Honda

Protection Plan to extend almost all of your warranty coverage (USA only).

Your Honda dealer can also supply information about, riding events, and information about safety training available in your local area, and the Honda Rider's Club of America (USA only).

Honda Rider's Club of America (HRCA)

The Honda Rider's Club of America (HRCA) sponsors local riding chapters at Authorized Honda Dealerships across the country. You can log on to the HRCA Clubhouse website for more information at www.hrca.honda.com.

USA Reporting Safety Defects

If you believe that your vehicle has a defect which could cause a crash or could cause injury or death, you should immediately inform the National Highway Traffic Safety Administration (NHTSA) in addition to notifying American Honda Motor Co., Inc.

If NHTSA receives similar complaints, it may open an investigation, and if it finds that a safety defect exists in a group of vehicles, it may order a recall and remedy campaign. However, NHTSA cannot become involved in individual problems between you, your dealer, or American Honda Motor Co., Inc.

To contact NHTSA, you may call the Vehicle Safety Hotline toll-free at: 1-888-327-4236

(TTY: 1-800-424-9153); go to <http://www.safercar.gov>;

or write to:

Administrator, NHTSA,
1200 New Jersey Avenue, SE.,
Washington, DC 20590.

You can also obtain other information about motor vehicle safety from:

<http://www.safercar.gov>.

Specifications

■ Main Components

Type	SC61
Overall length	100.6 in (2,555 mm)
Overall width	35.4 in (900 mm)
Overall height	45.3 in (1,150 mm)
Wheelbase	71.1 in (1,805 mm)
Minimum ground clearance	4.9 in (125 mm)
Caster angle	32° 00'
Trail	3.6 in (92 mm)
Curb weight	VT1300CX
	49 STATE 666 lb (302 kg)
	50 STATE 668 lb (303 kg)
	(meets California)
	VT1300CXA
50 STATE 681 lb (309 kg)	
(meets California)	
Canada 679 lb (308 kg)	
Maximum weight capacity*1	322 lb (146 kg)

*1 Including rider, passenger, all luggage, and accessories

Passenger capacity	Rider and 1 passenger
Minimum turning radius	11.8 ft (3.6 m)
Displacement	80.0 cu-in (1,312 cm ³)
Bore x stroke	3.52 x 4.11 in (89.5 x 104.3 mm)
Compression ratio	9.2:1
Fuel	Unleaded gasoline Recommended fuel octane number: Pump Octane Number (PON) 86 or higher.
Tank capacity	3.38 US gal (12.8 liters)
Battery	YTZ14S
	12V-11.2Ah (10 HR)
	1st 1.900
	2nd 1.230
	3rd 0.909
Gear ratios	4th 0.756
	5th 0.676
	Reduction ratios (primary / secondary / final)
	1.935 / 0.944 / 2.818

Specifications

■ Service Data

Tire size	Front	90/90-21M/C (54H)
	Rear	200/50-18M/C (76H)
Tire type		radial, tubeless
Recommended Tires	Front	DUNLOP D422F METZELER ME880
	Rear	DUNLOP D423 METZELER ME880
Tire air pressure	Front	33 psi (225 kPa, 2.25 kgf/cm ²)
	Rear	41 psi (280 kPa, 2.80 kgf/cm ²)
Minimum tread depth	Front	0.06 in (1.5 mm)
	Rear	0.08 in (2.0 mm)
Spark plugs	(standard)	DCPR6E (NGK) or XU20EPR-U (DENSO)
	(high speed riding)	DCPR7E (NGK) or XU22EPR-U (DENSO)
Spark plug gap	(non-adjustable)	0.031 to 0.035 in (0.80 to 0.90 mm)
Idle speed		930 ± 100 rpm

Recommended engine oil	API Service Classification SG or higher except oils labeled as energy conserving on the circular API service label, SAE 10W-30, JASO T 903 standard MA, Pro Honda GN4 4-stroke oil (USA & Canada) or Honda 4-stroke oil, or an equivalent motorcycle oil	
Engine oil capacity	After draining	3.7 US qt (3.5 liters)
	After draining & filter change	3.9 US qt (3.7 liters)
	After disassembly	4.5 US qt (4.3 liters)
Recommended final drive oil	Hypoid gear oil SAE 80	
Final drive oil capacity	After draining	4.4 US oz (130 cm ³)
	After disassembly	5.7 US oz (170 cm ³)
Recommended brake fluid	Honda DOT 4 Brake Fluid	
Cooling system capacity	2.68 US qt (2.54 liters)	
Recommended coolant	Pro Honda HP Coolant	

■ Bulbs

Headlight	12V-60/55W
Brake/Taillight	LED
Front turn signal lights	12V-21/5W x 2
Rear turn signal lights	12V-21W x 2
License plate light	12V-5W

■ Fuses

Main fuse	30A
Other fuses	VT1300CX 20A, 10A
	VT1300CXA 30A, 20A, 10A

■ Torque Specifications

Engine oil drain bolt	22 lbf-ft (30 N·m, 3.1 kgf·m)
Oil filter	19 lbf-ft (26 N·m, 2.7 kgf·m)
Final drive oil fill hole cap	9 lbf-ft (12 N·m, 1.2 kgf·m)
Final drive oil drain bolt	9 lbf-ft (12 N·m, 1.2 kgf·m)
Air cleaner housing cover bolts	1.1 lbf-ft (1.5 N·m, 0.2 kgf·m)
Front wheel axle bolt	47 lbf-ft (64 N·m, 6.5 kgf·m)
Front wheel axle pinch bolts	16 lbf-ft (22 N·m, 2.2 kgf·m)
Front wheel caliper fixing bolts	23 lbf-ft (31 N·m, 3.2 kgf·m)
Rear wheel axle nut	94 lbf-ft (127 N·m, 13.0 kgf·m)
Rear wheel axle holding bolt	20 lbf-ft (27 N·m, 2.8 kgf·m)
Rear brake bracket bolt	51 lbf-ft (69 N·m, 7.0 kgf·m)
Exhaust pipe joint nuts	17 lbf-ft (23 N·m, 2.3 kgf·m)
Muffler bracket bolt A, B, and nuts	20 lbf-ft (27 N·m, 2.8 kgf·m)

Information Record

VIN	
Engine No.	
Ignition Key No.	
Color Label & Code	
Owner's Name	
Address	
City/State	
Phone	
Dealer's Name	
Address	
City/State	
Phone	
Service Manager	

A	
ABS (Anti-lock Brake System)	
Indicator	20, 81
Accessories.....	13
Authorized Manuals.....	112
B	
Battery.....	39, 52
Brake Light Switch.....	76
Brakes	
Fluid.....	63
Pad Wear.....	64
Braking.....	10
Bulb	
Brake/Taillight.....	92
Front/Rear Turn Signal.....	92
Headlight.....	91
License Plate Light.....	93
C	
Caring for Your Motorcycle.....	99
Clock.....	18
Clutch System.....	65
Color Label.....	38
Compartment	
Owner's Manual.....	29
Coolant.....	43, 61
D	
Digital Clock Adjustment.....	19
E	
Electrical Trouble.....	90
Emission Control Systems.....	105
Engine	
Number.....	104
Oil.....	42, 57
Overheats.....	79
Starting.....	24
Stop Switch.....	22, 98
Stopping.....	98
Environment.....	103
F	
Final Drive Oil.....	43, 69
Flooded Engine.....	78

Fuel	
Recommended	27
Tank Capacity	27
Fuel Reserve Indicator	21
Fuses	41, 94
G	
Gasohol	111
Gasoline	27
H	
Headlight Aim	76
Headlight Dimmer Switch	22
Helmet Holder	28
High Beam Indicator	21
High Coolant Temperature Indicator	20, 79
Honda Contacts	114
Horn Button	22
I	
Ignition Cut-off System	
Banking Sensor	98
Side Stand	68
Ignition Key	97
Ignition Switch	23
Indicators	20
Information Record	120
Instruments	18
L	
Labels	7
Load Limits	14
Loading Guidelines	14
Low Oil Pressure Indicator	20, 80
M	
Maintenance	
Fundamentals	37
Importance	32
Safety	33
Schedule	34
Maximum Weight Limit	14
Modifications	13

N		
Neutral Indicator.....	21	
O		
Odometer	18, 98	
Oil		
Engine	42, 57	
Final Drive.....	43, 69	
Overheating	79	
Oxygenated Fuels	111	
P		
Parking	12	
Parts Location.....	16	
PGM-FI (Programmed Fuel Injection)		
malfunction indicator lamp (MIL)	20, 80	
Protective Apparel	9	
R		
Recommended		
Final Drive Oil.....	43	
Fuel.....	27	
Refueling.....	27	
		Removal
		Seat.....
		48
		Side Cover.....
		50
		Reporting Safety Defects (U.S.)
		116
		Riding Precautions
		10
		S
		Safety Labels.....
		7
		Safety Precautions.....
		9
		Shifting Gears.....
		26
		Side Stand
		68
		Side Stand Ignition Cut-off System
		68
		Specifications.....
		117
		Start Button
		22
		Starting the Engine.....
		24
		Steering Lock.....
		23
		Stopping Engine.....
		98
		Storage
		Compartment.....
		29
		Owner's Manual.....
		29
		Storing Your Motorcycle.....
		101
		Switches
		22

T

Throttle 73

Tires

Air Pressure 44

Puncture..... 82

Replacing 46

Transporting Your Motorcycle 102

Tripmeter 18, 98

Turn Signal Indicator..... 21

Turn Signal Switch..... 22

V

Vehicle Identification Number 104

W

Warning Indicators ON 80

Warranty Coverage and Service 113

Washing Your Motorcycle 99

Weight Limit..... 14, 117

Wheels

Front removal 83

Rear removal 86