

Contents

These pages give an overview of the contents of your owner's manual. The first page of each section lists the topics covered in that section.

Motorcycle Safety	1
Important safety information you should know, plus a look at the safety-related labels on your motorcycle.	
Instruments & Controls	11
The location and function of gauges, indicators, controls, and the Multi Information Display on your motorcycle and operating instructions for various controls and features.	
Before Riding	43
The importance of wearing a helmet and other protective gear, how to make sure you and your motorcycle are ready to ride, and important information about loading.	
Basic Operation & Riding	71
How to start and stop the engine, shift gears, and brake. Also, riding precautions and important information about riding with a passenger or cargo.	
Audio Systems	97
The location, function, and operation of the audio components on your motorcycle.	
Servicing Your Honda	137
Why your motorcycle needs regular maintenance, what you need to know before servicing your Honda, an owner maintenance schedule, and instructions for specific maintenance and adjustment items.	

Contents

Tips	207
How to store and transport your motorcycle and how to be an environmentally responsible rider.	
Taking Care of the Unexpected	213
What to do if you have a flat tire, your engine won't start, etc.	
Technical Information	239
ID numbers, technical specifications, and other technical facts.	
Consumer Information	257
Information on warranties, emission controls, how to get Honda service manuals, and...	
“Reporting Safety Defects”	266
Table of Contents	268
Sequential listing of topics in this owner's manual.	
Index	276
Quick Reference	
Handy facts about fuel, engine oil, tire sizes, and air pressures.	

**2010
Honda GL1800
GOLDWING
OWNER'S MANUAL**

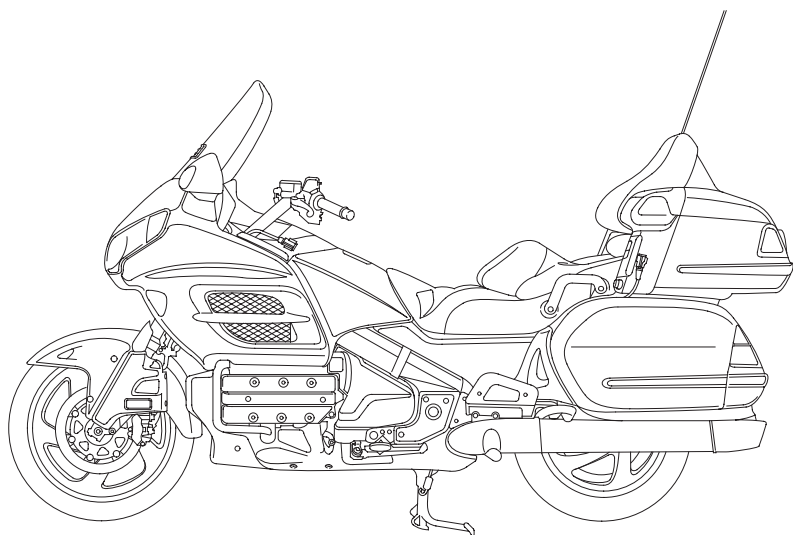

Introduction

Congratulations on choosing a GL1800 GOLDWING motorcycle.

When you own a Honda, you're part of a worldwide family of satisfied customers — people who appreciate Honda's reputation for building quality into every product.

Your GOLDWING has earned its reputation as the ultimate luxury touring motorcycle. It comes loaded with power, unequaled cargo space, a sophisticated audio system, adjustable windscreen, suspension, a Tire Pressure Monitoring System (TPMS), ventilation, and other unique features to provide maximum convenience and comfort. Additionally, there are special packages available: Anti-Lock Brake System (ABS), Premium Audio, Navigation System with optional XM Satellite Radio, Airbag, and Comfort.

Before riding, take time to get acquainted with your motorcycle and how it works. To protect your investment, we urge you to take responsibility for keeping your motorcycle well maintained. Scheduled service is a must, of course. But it's just as important to observe the break-in guidelines, and perform all pre-ride and other periodic checks detailed in this manual.

We also recommend that you read this owner's manual before you ride. It's full of facts, instructions, safety information, and helpful tips. To make it easy to use, the manual contains a detailed list of topics at the beginning of each section, and both an in-depth table of contents and an index at the back of the book.

As you read this manual, you will find information that is preceded by a **NOTICE** symbol. This information is intended to help you avoid damage to your Honda, other property, or the environment.

Introduction

Read the Warranties Booklet (page 261) thoroughly so you understand the coverages that protect your new Honda and are aware of your rights and responsibilities.

If you have any questions, or if you ever need special service or repairs, remember that your Honda dealer knows your motorcycle best and is dedicated to your complete satisfaction.

Please report any change of address or ownership to your Honda dealer so we will be able to contact you concerning important product information.

You may also want to visit our website at www.honda.com.

Happy riding!

California Proposition 65 Warning

WARNING: This product contains or emits chemicals known to the State of California to cause cancer and birth defects or other reproductive harm.

A Few Words About Safety

Your safety, and the safety of others, is very important. And operating this motorcycle safely is an important responsibility.



To help you make informed decisions about safety, we have provided operating procedures and other information on labels and in this manual. This information alerts you to potential hazards that could hurt you or others.

Of course, it is not practical or possible to warn you about all hazards associated with operating or maintaining a motorcycle. You must use your own good judgment.

You will find important safety information in a variety of forms, including:

- **Safety Labels** — on the motorcycle.
- **Safety Messages** — preceded by a safety alert symbol  and one of three signal words: **DANGER**, **WARNING**, or **CAUTION**.

These signal words mean:

 DANGER	You WILL be KILLED or SERIOUSLY HURT if you don't follow instructions.
 WARNING	You CAN be KILLED or SERIOUSLY HURT if you don't follow instructions.
 CAUTION	You CAN be HURT if you don't follow instructions.

- **Safety Headings** — such as Important Safety Reminders or Important Safety Precautions.
- **Safety Section** — such as Motorcycle Safety.
- **Instructions** — how to use this motorcycle correctly and safely.

This entire manual is filled with important safety information — please read it carefully.

Motorcycle Safety

This section presents some of the most important information and recommendations to help you ride your motorcycle safely. Please take a few moments to read these pages. This section also includes information about the location of safety labels on your motorcycle.

Important Safety Information	2
Accessories & Modifications.....	4
Safety Labels.....	6

Important Safety Information

Your motorcycle can provide many years of service and pleasure — if you take responsibility for your own safety and understand the challenges you can meet while riding.

There is much that you can do to protect yourself when you ride. You'll find many helpful recommendations throughout this manual. The following are a few that we consider to be most important.

Always Wear a Helmet

It's a proven fact: helmets significantly reduce the number and severity of head injuries. So always wear an approved motorcycle helmet and make sure your passenger does the same. We also recommend that you wear eye protection, sturdy boots, gloves, and other protective gear (page 44).

Take Time to Learn & Practice

Even if you have ridden other motorcycles, take time to become familiar with how this motorcycle works and handles. Practice in a safe area until you build your skills and get accustomed to the motorcycle's size and weight.

Because many accidents involve inexperienced or untrained riders, we urge all riders to take a certified course approved by the Motorcycle Safety Foundation (MSF). See page 46.

Ride Defensively

The most frequent motorcycle collision happens when a car turns left in front of a motorcycle. Another common situation is a car moving suddenly into your lane.

Always pay attention to other vehicles around you, and do not assume that other drivers see you. Be prepared to stop quickly or make an evasive maneuver. For other riding tips, see the booklet, *You and Your Motorcycle Riding Tips*, which came with your new motorcycle (USA only).

Important Safety Information

Make Yourself Easy to See

Some drivers do not see motorcycles because they are not looking for them. To make yourself more visible, wear bright reflective clothing, position yourself so other drivers can see you, signal before turning or changing lanes, and use your horn when it will help others notice you.

Ride within Your Limits

Pushing limits is another major cause of motorcycle accidents. Never ride beyond your personal abilities or faster than conditions warrant. Remember that alcohol, drugs, fatigue, and inattention can significantly reduce your ability to make good judgments and ride safely.

Don't Drink and Ride

Alcohol and riding don't mix. Even one drink can reduce your ability to respond to changing conditions, and your reaction time gets worse with every additional drink. So don't drink and ride, and don't let your friends drink and ride either.

Keep Your Honda in Safe Condition

It's important to keep your motorcycle properly maintained and in safe riding condition. To help avoid problems, inspect your motorcycle before every ride and perform all recommended maintenance. Never exceed load limits (page 50), and do not modify your motorcycle (page 5) or install accessories that would make your motorcycle unsafe (page 4).

Accessories & Modifications

Modifying your motorcycle or using non-Honda accessories can make your motorcycle unsafe. Before you consider making any modifications or adding an accessory, be sure to read the following information.

WARNING

Improper accessories or modifications can cause a crash in which you can be seriously hurt or killed.

Follow all instructions in this owner's manual regarding accessories and modifications.

Accessories

We strongly recommend that you use only Honda Genuine Accessories that have been specifically designed and tested for your motorcycle. Because Honda cannot test all other accessories, you must be personally responsible for proper selection, installation, and use of non-Honda accessories.

Check with your Honda dealer for assistance and always follow these guidelines:

- Make sure the accessory does not obscure any lights, reduce ground clearance and lean angle, limit suspension travel or steering travel, alter your riding position, or interfere with operating any controls.
- Do not add any electrical equipment that will exceed the motorcycle's electrical system capacity (page 245). A blown fuse can cause a loss of lights or engine power (page 232).
- Do not pull a trailer or sidecar with your motorcycle. This motorcycle was not designed for these attachments, and their use can seriously impair your motorcycle's handling.
- Carefully consider the weight of any accessories and any cargo stored in those accessories to avoid exceeding the maximum weight limits. For more information, see *Load Limits*, page 50.
- Modifying the tire pressure monitoring system (TPMS) or any other part of your motorcycle's safety systems could make the systems ineffective (page 85).

Accessories & Modifications

Modifications

We strongly advise you not to remove any original equipment or modify your motorcycle in any way that would change its design or operation. Such changes could seriously impair your motorcycle's handling, stability, and braking, making it unsafe to ride.

Removing or modifying your lights, exhaust system, emission control system, or other equipment can also make your motorcycle illegal.

Safety Labels

Safety labels on your motorcycle either warn you of potential hazards that could cause serious injury or they provide important safety information. Read these labels carefully and don't remove them.

If a label comes off or becomes hard to read, contact your Honda dealer for a replacement.

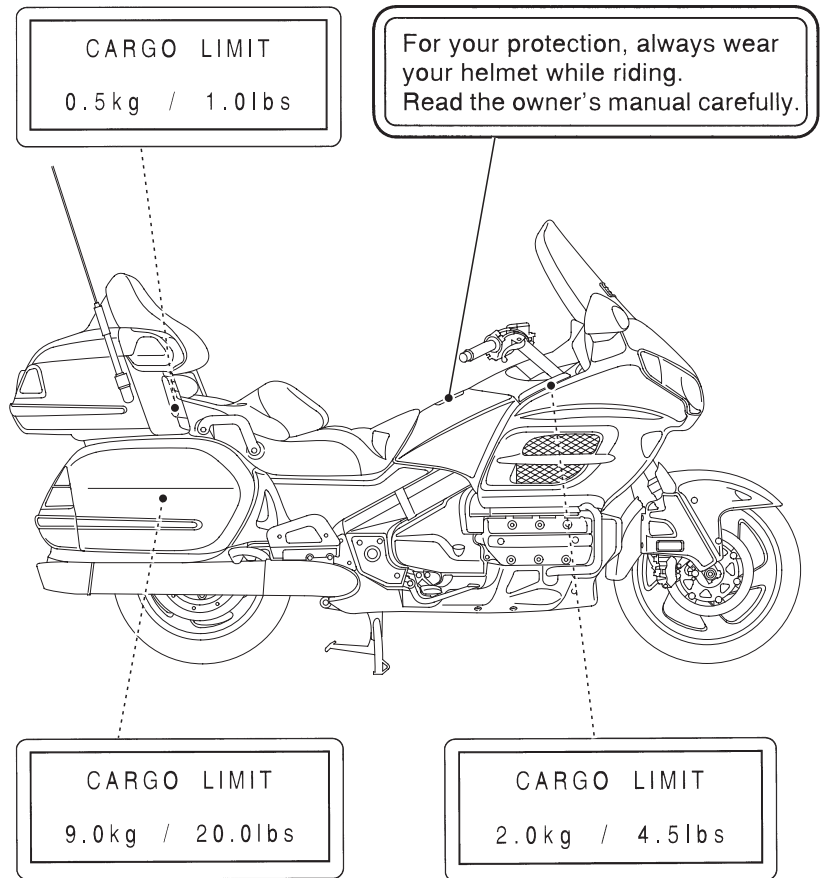

(Models not equipped with Airbag)

Safety Labels

CARGO LIMIT
0.5kg / 1.0lbs

CARGO LIMIT
9.0kg / 20.0lbs

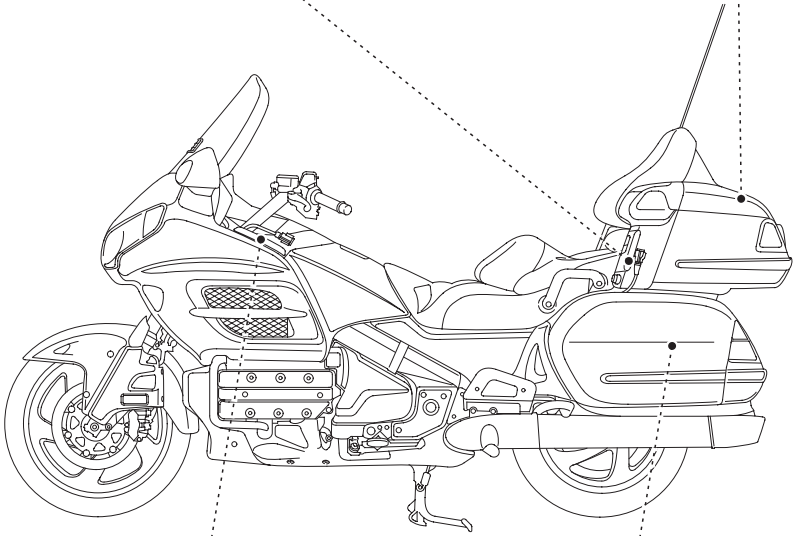

CARGO LIMIT
2.0kg / 4.5lbs

CARGO LIMIT
9.0kg / 20.0lbs

Safety Labels

⚠ WARNING

Improper loading can cause a crash and you may be seriously hurt or killed. See "Load Limits and Guidelines" in your Owner's Manual for complete instructions.

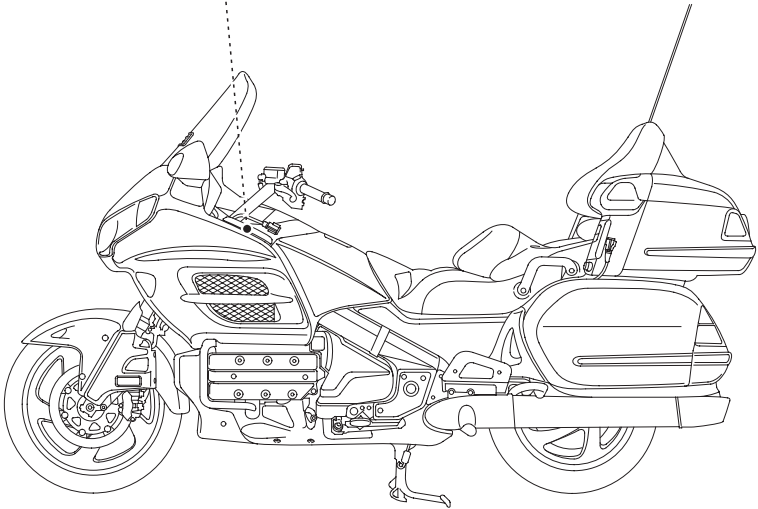

Safety Labels

< For USA >

TIRE INFORMATION	
Cold tire pressures: [Up to maximum weight capacity] Front 250kPa 2.50kg/cm ² 36psi Rear 280kPa 2.80kg/cm ² 41psi [Up to 90kg(200lbs) load] Front 250kPa 2.50kg/cm ² 36psi Rear 280kPa 2.80kg/cm ² 41psi Maximum weight capacity: 186kg(410lbs) Tire size: Front 130/70R18M/C 63H Rear 180/60R16M/C 74H	Tire brand: Front DUNLOP Rear D250 BRIDGESTONE G709 RADIAL G704 RADIAL Min. recommend tire center tread depth: Front 1.5mm(0.06in.) Rear 2.0mm(0.08in.) Read owner's manual. This motorcycle is equipped with tubeless tires.

< For Canada >

TIRE INFORMATION	
Cold tire pressures: [Up to maximum weight capacity] Front 250kPa 2.50kg/cm ² 36psi Rear 280kPa 2.80kg/cm ² 41psi [Up to 90kg(200lbs) load] Front 250kPa 2.50kg/cm ² 36psi Rear 280kPa 2.80kg/cm ² 41psi Maximum weight capacity: 190kg(419lbs) Tire size: Front 130/70R18M/C 63H Rear 180/60R16M/C 74H	Tire brand: Front DUNLOP Rear D250 BRIDGESTONE G709 RADIAL G704 RADIAL Min. recommend tire center tread depth: Front 1.5mm(0.06in.) Rear 2.0mm(0.08in.) Read owner's manual. This motorcycle is equipped with tubeless tires.

NOTICE

This motorcycle is equipped with a Tire Pressure Monitoring System. (TPMS)
 Before removing and installing the tire,
 See owner's manual.

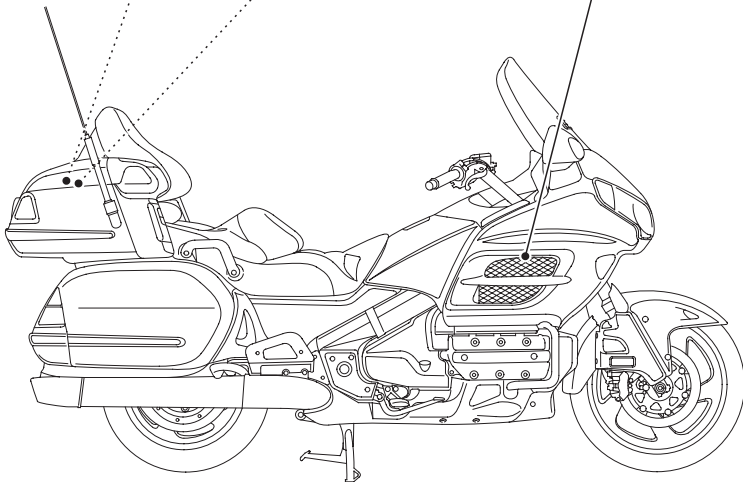

Instruments & Controls

This section shows the location of all gauges, indicators, and controls you would normally use before or while riding your motorcycle.

The items listed on this page are described in this section. Instructions for other components are presented in other sections of this manual where they will be most useful.

Operation Component Locations	12
Gauges & Indicators.....	16
Multi Information Display	22
Opening/Ending Ceremony	23
On/Off-Opening/Ending Ceremony.....	24
Special Message for Opening/Ending Ceremony	25
Odometer/Tripmeter.....	27
Switch the Day Mode Display and Night Mode Display.....	28
Display Illumination Adjustment.....	29
Digital Clock	31
Air Temperature Meter	32
Travel Trunk & Saddlebags Open Indicator	33
Display Type Selection	34
Changing the Information Display	35
Controls & Features.....	37
Ignition Switch	37
Engine Stop Switch	38
Start/Reverse Button	39
Reverse (RVS) Switch	39
Cruise Control Switches.....	39
Headlight Dimmer Switch	40
Turn Signal Switch.....	40
Horn Button	40
Audio Control Switches	40
Hazard Switch	41
Headlight Beam Adjustment Knob.....	42
Rear Suspension Spring Pre-load Adjustment Switch	42
Ventilation Controls	42
Windscreen Height Adjustment.....	42

Operation Component Locations

(Models not equipped with Navigation System)

audio system controls

windscreen height lever

left handlebar controls

windscreen ventilation louver

(Models equipped with Comfort Package)

clutch lever

handgrip heater switch

front seat heater switch

windscreen height lever

left fairing pocket

front brake lever

throttle grip

left fairing panel controls

right handlebar controls

right fairing pocket

right side ventilation louver

fairing pocket lock

audio system controls

ignition switch

left side ventilation louver

Operation Component Locations

(Models equipped with Navigation System)

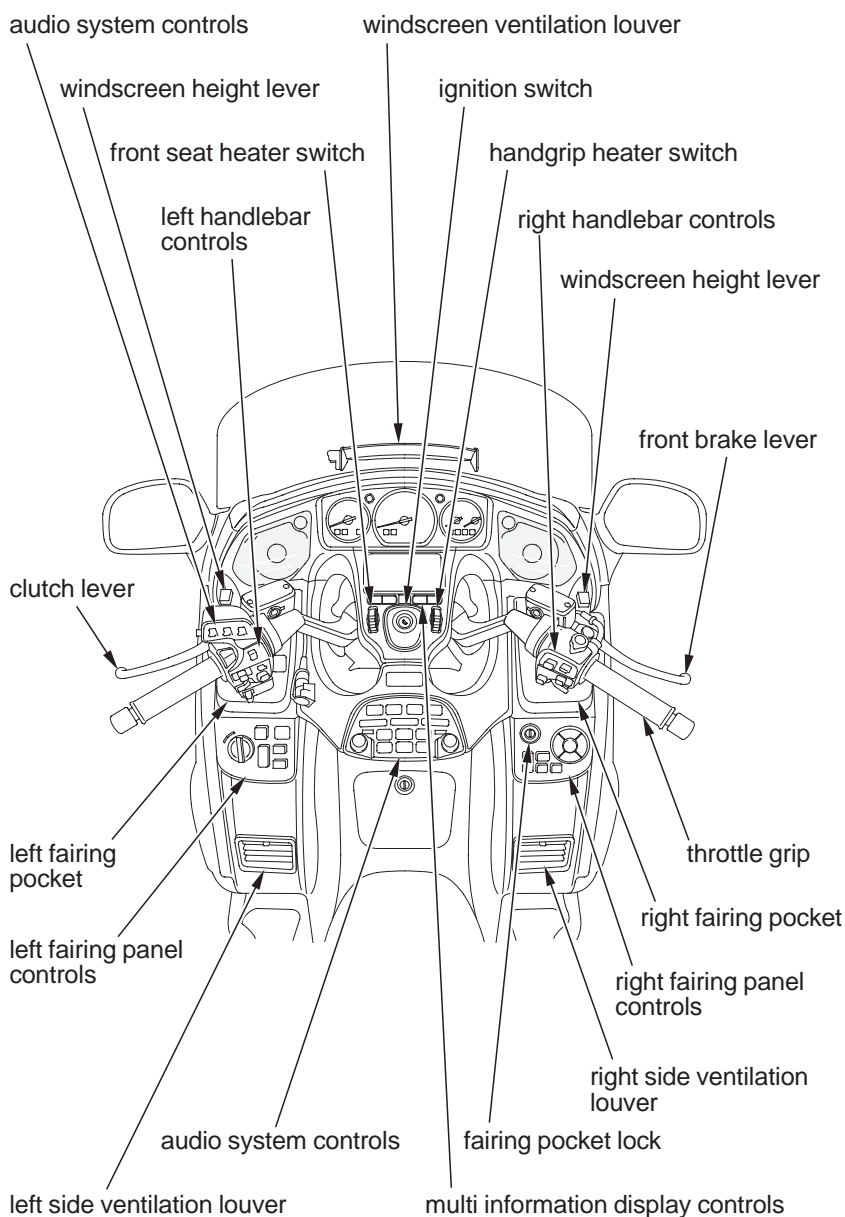

Operation Component Locations

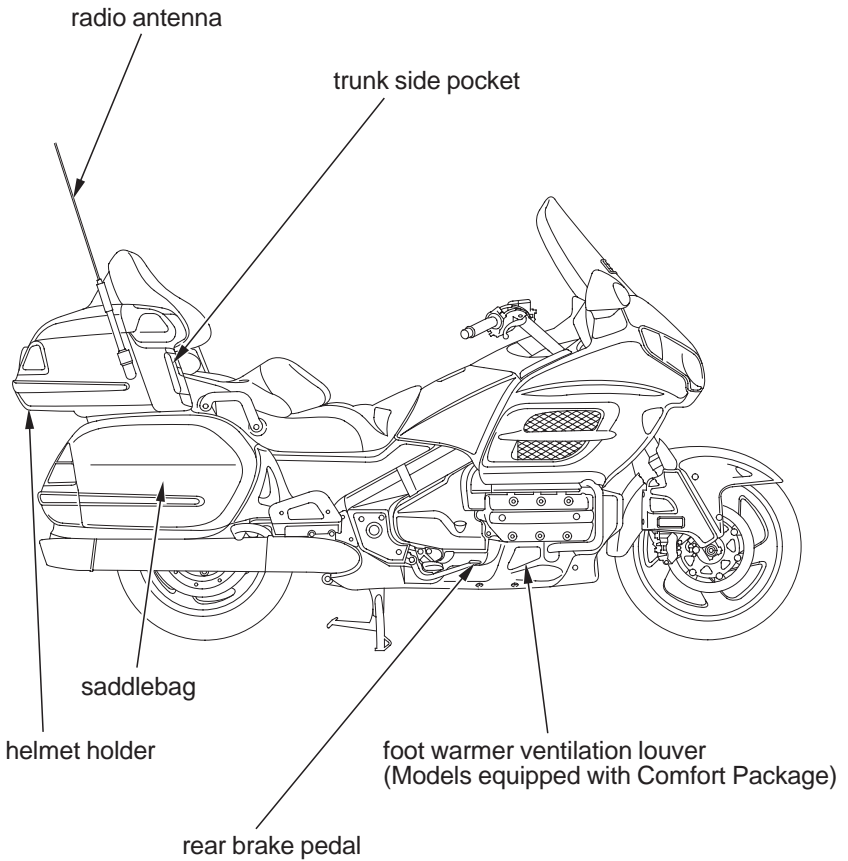

Operation Component Locations

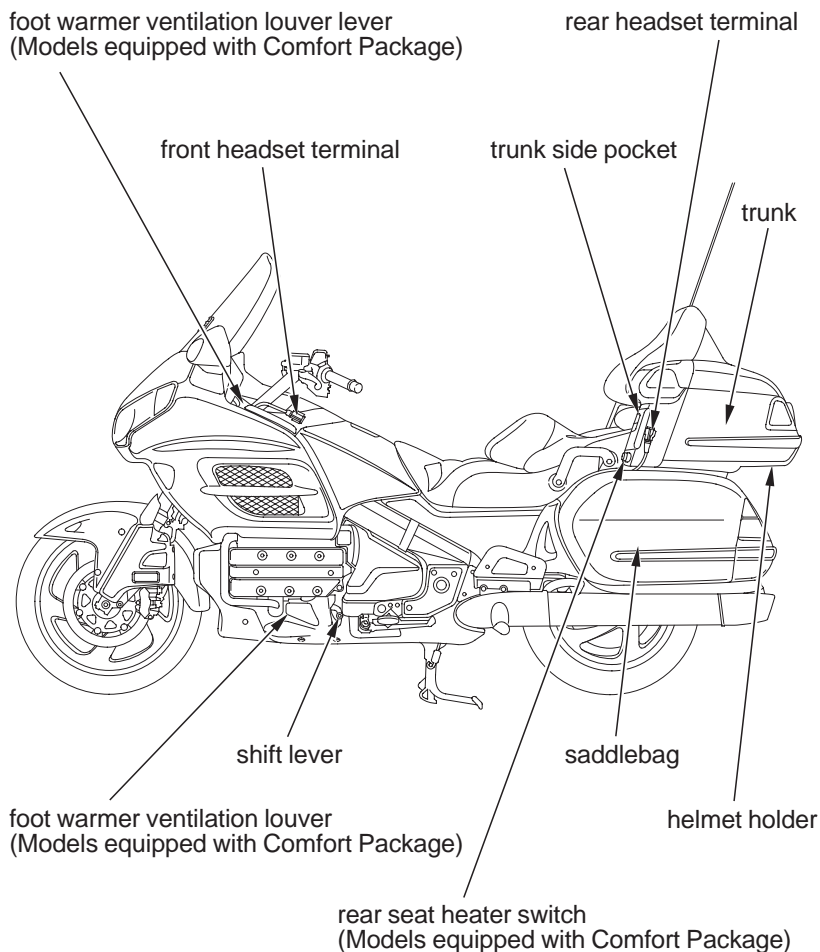

Gauges & Indicators

The gauges and indicators on your motorcycle keep you informed, alert you to possible problems, and make your riding safer and more enjoyable. Refer to the gauges and indicators frequently. Their functions are described on the following pages.

USA: Speedometer, odometer & tripmeter read in miles.

Canada: Speedometer, odometer & tripmeter read in kilometers.

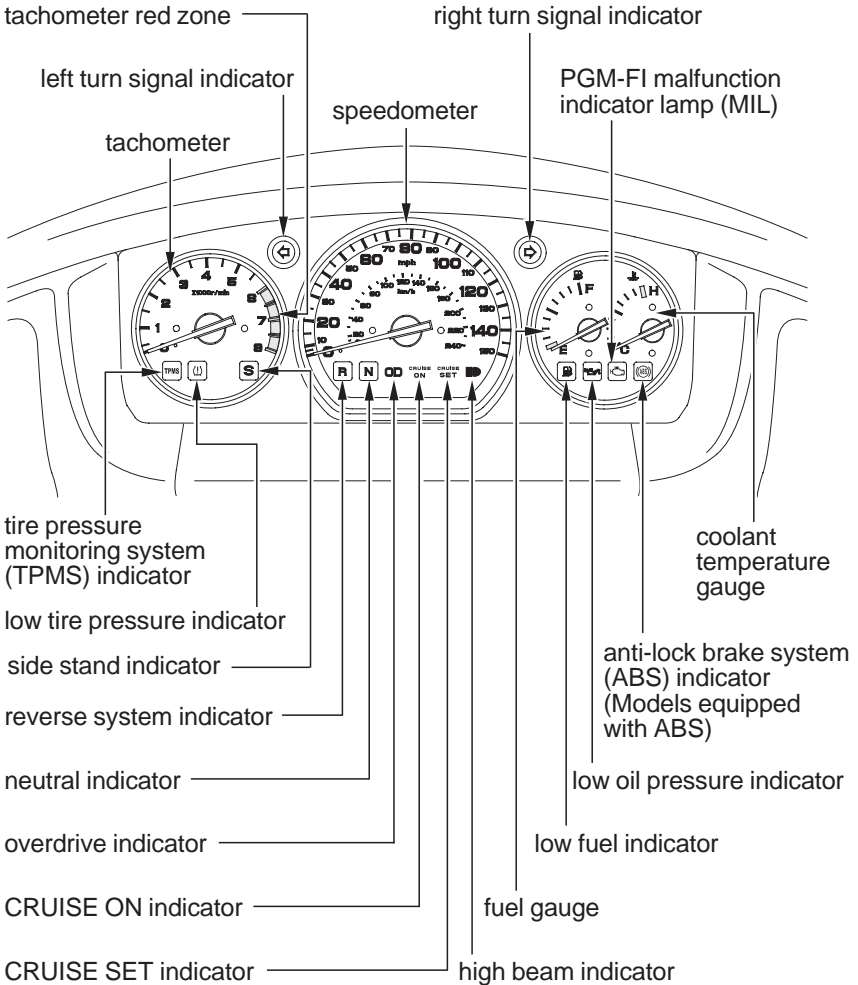

Gauges & Indicators

Lamp Check

Most of the indicator lights come on when you turn the ignition switch ON so you can check that they are working. Some indicators turn off after a few seconds; others remain on until or after the engine is started. The ABS indicator goes off after you ride the motorcycle at a speed above 6 mph (10 km/h). All indicators are identified on the following pages with the words: *Lamp Check*.

When applicable, the high beam and neutral indicators come on when you turn the ignition switch ON and remain on until you select the low beam or shift out of neutral.

If one of these indicators does not come on when it should, have your Honda dealer check for problems.

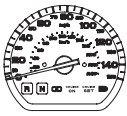

speedometer

Shows riding speed in miles (USA) or kilometers (Canada) per hour.



tachometer

Shows engine speed in revolutions per minute (rpm).



tachometer red zone

Shows excessive engine rpm range (indicated from the beginning of the tachometer red zone) in which operation may damage the engine. Do not let the tachometer needle enter the red zone.

Gauges & Indicators



turn signal indicator (green)

Flashes when either turn signal operates.



reverse system indicator

Lights when the reverse system is engaged.



neutral indicator (green)

Lights when the transmission is in neutral.



overdrive indicator

Lights when the transmission is in overdrive (5th gear).



low oil pressure indicator (red)

Lights when engine oil pressure is low enough to cause engine damage. If the low oil pressure indicator lights during operation, pull safely to the side of the road. See page 231 for instructions and cautions. *Lamp Check.*

Gauges & Indicators



PGM-FI malfunction indicator lamp (MIL) (amber)

Lights when there is any abnormality in the PGM-FI (Programmed Fuel Injection) system. Should also light for a few seconds and then go off when the ignition switch is turned ON and the engine stop switch is at RUN. If the indicator comes on at any other time, reduce speed and take your motorcycle to a Honda dealer as soon as possible. *Lamp Check.*



tire pressure monitoring system (TPMS) indicator (amber)

Lights when there is any abnormality in the tire pressure monitoring system (TPMS). Should also light for a few seconds and then go off when the ignition switch is turned ON. See page 85 for instructions and cautions. *Lamp Check.*

If the indicator turns on and stays on at any other time, there is a problem with the TPMS, and the indicator will remain on until the problem is solved.

Or if the TPMS indicator does not turn on when you turn the ignition switch to ON, it is possible there is a problem and it will not turn on until the problem is solved.

With this indicator on, the low tire pressure indicator will not come on when a tire loses pressure, take the motorcycle to your Honda dealer to have the system checked.



low tire pressure indicator (amber)

Flashes or lights when one or more of your motorcycle tires are significantly low on pressure. Should also light for a few seconds and then go off when the ignition switch is turned ON. If the indicator comes on while riding, stop the motorcycle in a safe place and check the front and rear tires for inflation.

See page 85 for instructions and cautions. *Lamp Check.*

Gauges & Indicators

(Models equipped with ABS)



Anti-Lock Brake System indicator (ABS) (amber)

Lights when there is any abnormality in the anti-lock brake system (ABS). Normally, this indicator comes on when the ignition switch is turned ON, and goes off after you ride the motorcycle at a speed above 6 mph (10 km/h). If the indicator comes on while riding, stop the motorcycle in a safe place and turn off the engine. Refer to *ABS Indicator*, page 83 . For information about ABS, see page 82 . *Lamp Check*.



CRUISE ON indicator

Lights when the CRUISE CONTROL master switch is on.



CRUISE SET indicator

Lights when the cruise control SET/DECEL switch is on.



high beam indicator (blue)

Lights when the headlight is on high beam.



side stand indicator (amber)

Lights when the side stand is put down — to indicate that the side stand ignition cut-off system (page 73) is activated.

Gauges & Indicators



low fuel indicator

Lights as a reminder to refuel soon. The indicator comes on when there is about 1.16 US gal (4.4 liters) left in the fuel tank. *Lamp Check.*



fuel gauge

Shows the approximate fuel supply available, if your motorcycle is on a level surface.

At F (Full) there are 6.6 US gal (25 liters), including reserve supply. When the gauge needle enters the red band, fuel will be low and you should refill the tank as soon as possible. The amount of fuel left in the tank when the needle enters the red band is approximately 0.79 US gal (3.0 liters).



coolant temperature gauge

Shows engine coolant temperature. When the needle moves above the C (cold) mark, the engine is warm enough to start riding. If the needle approaches the H (hot) mark, pull safely to the side of the road. See page 229 for instructions and cautions.

Multi Information Display

Your motorcycle is equipped with a Multi Information Display that presents various displays. This section explains display functions and operations.

(Models not equipped with Navigation System)

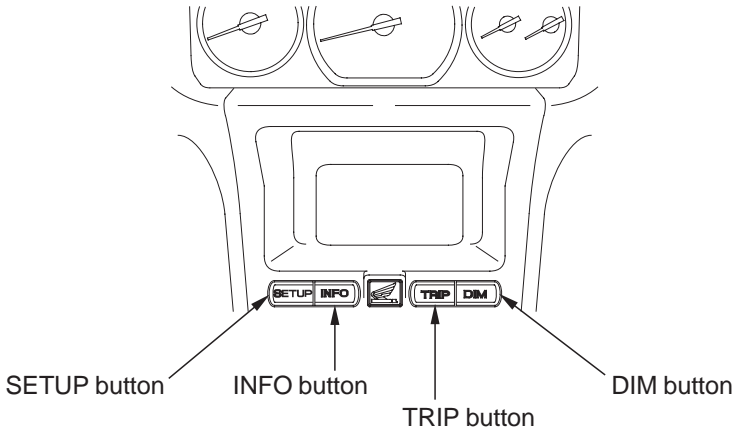

(Models equipped with Navigation System)

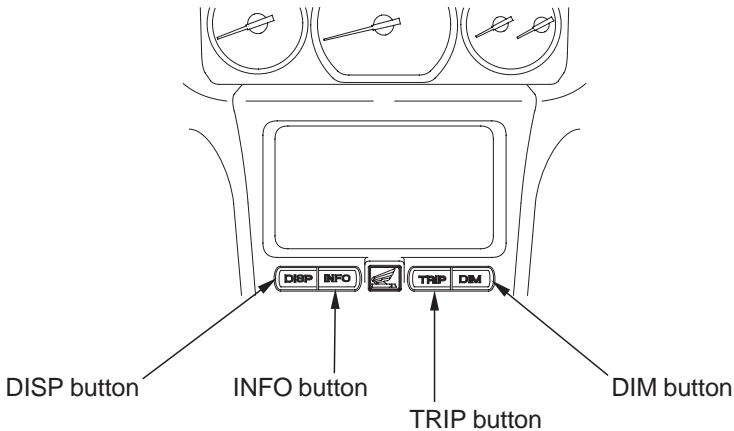

The Opening/Ending Ceremony and Clock can be set with the Setup/Info Menu of the Navigation System. Refer to the Navigation System Manual for further information.

Multi Information Display

On/Off-Opening/Ending Ceremony

(Models not equipped with Navigation System)

The opening/ending ceremony can be turned off.

1. Push the SETUP button to show the CLOCK ADJUST display (page 31).
2. Push the DIM button to show the OPENING/ENDING CEREMONY display.
3. Push the TRIP or INFO button to switch ON/OFF.
4. Push the SETUP button to fix the setting.

When approximately 5 seconds pass without operating a button on the OPENING/ENDING CEREMONY display, the display automatically returns to the previous display.

ceremony display ON

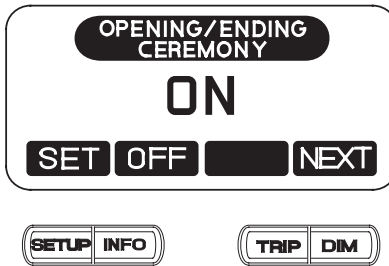

ceremony display OFF

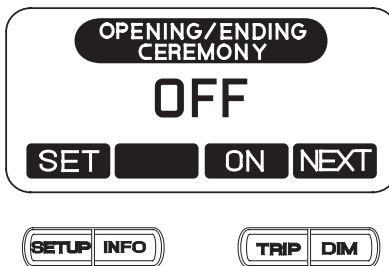

Multi Information Display

Special Message for Opening/Ending Ceremony

(Models not equipped with Navigation System)

1. Select "ON" on the OPENING/ENDING CEREMONY display (page 24).
2. Push and hold the TRIP button. Push and hold the INFO button. Then push the SETUP button.

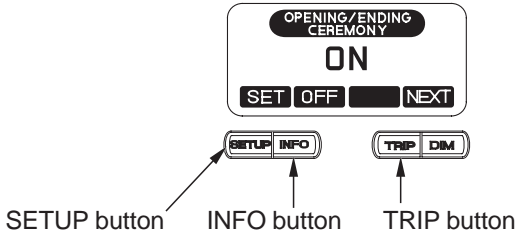

3. The display should now show "STANDARD" in the middle line.
4. Use the TRIP button to select the "SPL" function.
The display should now show "SPECIAL!" in the middle line.

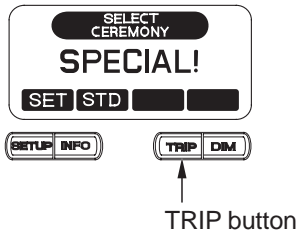

5. Push the SETUP button to select the "SET" function.
The display should now show "CHANGE OK?" in the middle line.
6. Push the SETUP button to select the "YES" function.

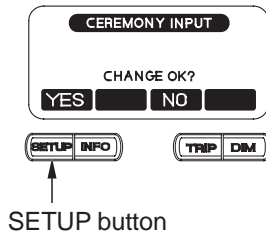

Multi Information Display

7. Use the INFO and TRIP buttons to cycle through the alphabet, number and symbol selection.

Capital Letters

A B C D E F G H I J K L M N O P Q R S T U V W X Y Z

Numbers

0 1 2 3 4 5 6 7 8 9

Symbols

! " # \$ % & ' () * + , - . / > = < ?

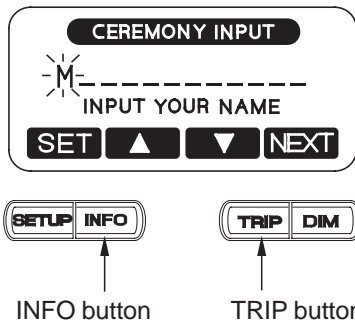

8. When you have completed your message, push the SETUP button to select the "SET" function which will lock in your special message to be used for the opening and ending ceremony.

When approximately 5 seconds pass without operating a button, the display automatically returns to the previous display.

Multi Information Display

Odometer/Tripmeter

- ODO (Odometer) — shows the total miles (USA) or kilometers (Canada) ridden.
- TRIP (Tripmeter) — shows the number of miles (USA) or kilometers (Canada) ridden since you last reset the meter.

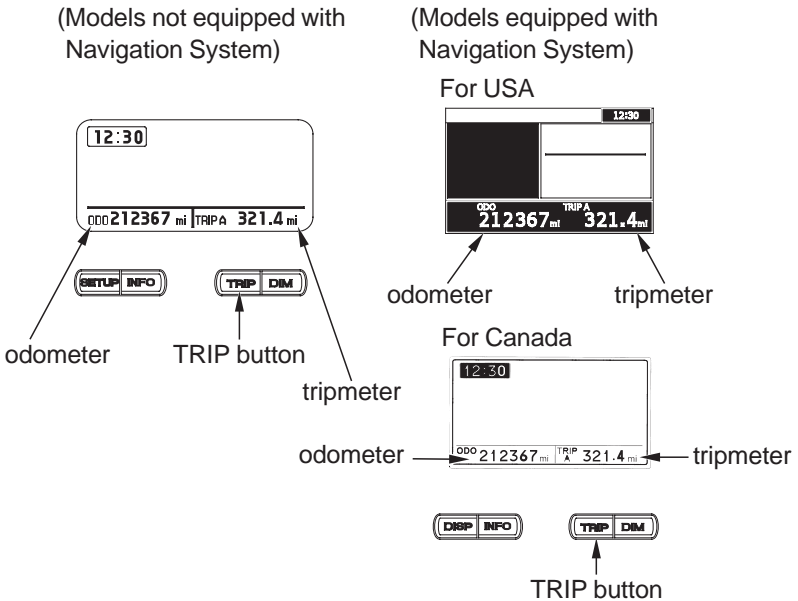

The tripmeter will show mileage in two sub modes, “TRIP A” and “TRIP B.” Push the TRIP button to select the “TRIP A” or “TRIP B” mode.

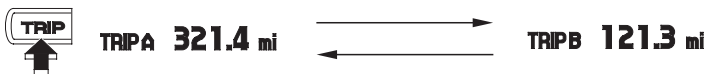

To reset the tripmeter, push and hold the TRIP button with the display in the “TRIP A” or “TRIP B” mode.



Multi Information Display

Switch the Day Mode Display and Night Mode Display

(Models equipped with Navigation System)

The display automatically switches to the Day mode or Night mode in accordance with the time. To switch the display manually, push and hold the DIM button.

Refer to the Navigation System Manual for further information.

For USA

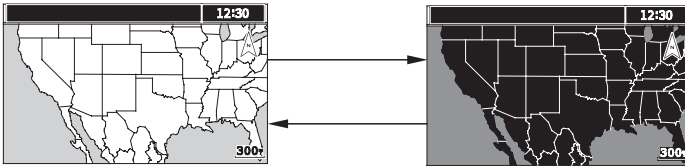

For Canada

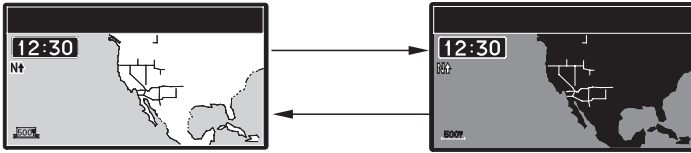

DIM button



DIM button

Multi Information Display

Display Illumination Adjustment

(Models not equipped with Navigation System)

To adjust the brightness of the display:

Push the DIM button once. “DIMMER” will display.

- To brighten the display ——— push the TRIP button (+).
- To darken the display ——— push the INFO button (-).
(The brighter and darker ranges each have six steps.)
- To set the selected step ——— push the SETUP button.

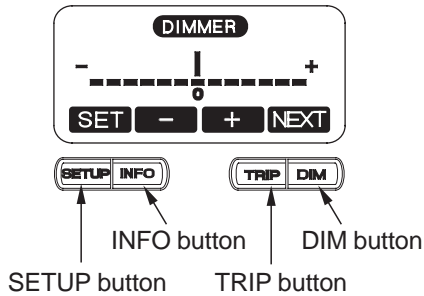

Multi Information Display

(Models equipped with Navigation System)

To adjust the brightness of the display:

Push the DIM button once. The display shows “Dimmer/Day” at Day mode, while it shows “Dimmer/Night” at Night mode.

- To brighten the display ——— push the TRIP button (+).
- To darken the display ——— push the INFO button (-).
(The brighter and darker ranges each have six steps.)
- To set the selected step ——— push the DISP button.

To switch the display between “Dimmer/Day” and “Dimmer/Night”, select the display between Day mode and Night mode (page 28) and push the DIM button.

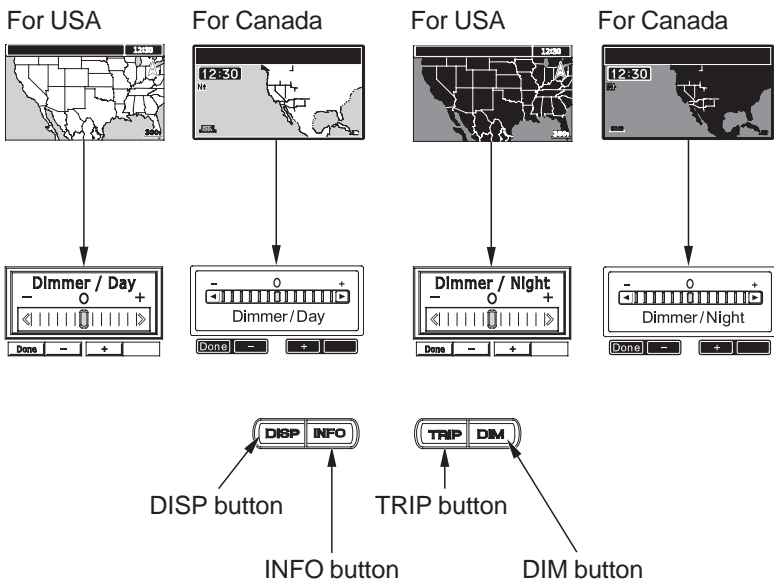

When approximately 5 seconds pass without operating a button, the display automatically returns to the previous display.

The display can become dark when the display is very hot. If it does not restore the original brightness, consult your Honda dealer.

Multi Information Display

Digital Clock

(Models not equipped with Navigation System)

The display shows the hour and minute.

To adjust the time:

1. Turn the ignition switch to ON or ACC.
2. Push the SETUP button once. “CLOCK ADJUST” will display.
3. To set the hour, press and release the INFO button until the desired hour appears.
 - Quick setting — push and hold the INFO button until the desired hour appears.
4. To set the minute, press and release the TRIP button until the desired minute appears.
 - Quick setting — push and hold the TRIP button until the desired minute appears.
5. Once the time is selected, push the SETUP button to enter the time.

When approximately 5 seconds pass without operating a button on the CLOCK ADJUST display, the display automatically returns to the previous display.

Be sure to push the SETUP button to enter your adjusted time in the system.

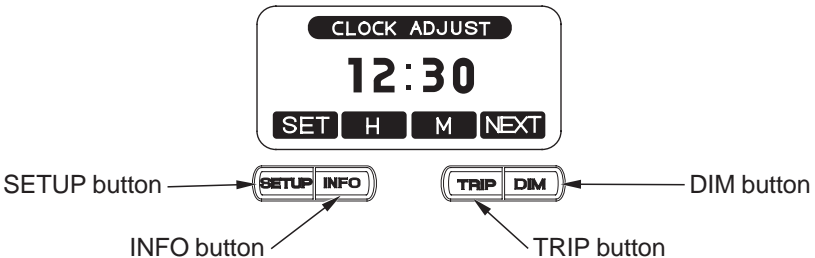

(Models equipped with Navigation System)

The navigation system receives signals from the Global Positioning System (GPS) and automatically sets the time display based on the time zone you select. You may also set the time manually using the “Other” option. Refer to the Navigation System Manual.

Multi Information Display

Air Temperature Meter

Push the INFO button once to display the air temperature.
After 5 seconds, the previous display returns.

USA: Fahrenheit (°F)

Canada: Centigrade (°C)

Temperature Display

(Models not equipped with Navigation System)

Below 13°F (−11°C)	“- -” is displayed
Between: 14°F – 122°F (−10°C – 50°C)	actual air temperature is indicated.
Above 122°F (50°C)	The display will remain and blink “122°F (50°C)”

(Models equipped with Navigation System)

Below 13°F (−11°C)	“- -” is displayed
Between: 14°F – 158°F (−10°C – 70°C)	actual air temperature is indicated.
Above 158°F (70°C)	The display will remain “158°F (70°C)”

The temperature sensor is located in the upper fairing. Therefore, the temperature reading can be affected by heat reflection from the road surface, engine heat, and the exhaust from the surrounding traffic. This can cause an error in the temperature reading when your speed is under 19 mph (30 km/h).

For USA

83°F

(Models not equipped with Navigation System)



INFO button

For Canada

23°C

(Models equipped with Navigation System)



INFO button

Multi Information Display

Travel Trunk & Saddlebags Open Indicator

This indicator turns on when the ignition switch is ON and your motorcycle's travel trunk or saddlebags are open.

If all compartments are not fully closed, the display will blink OPEN and indicate the open compartment(s).

(Models not equipped with Navigation System)



open indicator

(Models equipped with Navigation System)

For USA

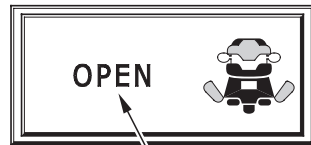

open indicator

For Canada



Travel Trunk open



Saddlebag open



Multi Information Display

Display Type Selection

(Models equipped with Navigation System)

Press the DISP button to toggle between:

- The Multi Information Display (time, odometer, and tripmeter)
- A Navi full screen map with the time
- A split screen with the Multi information condensed in a bar below the map.

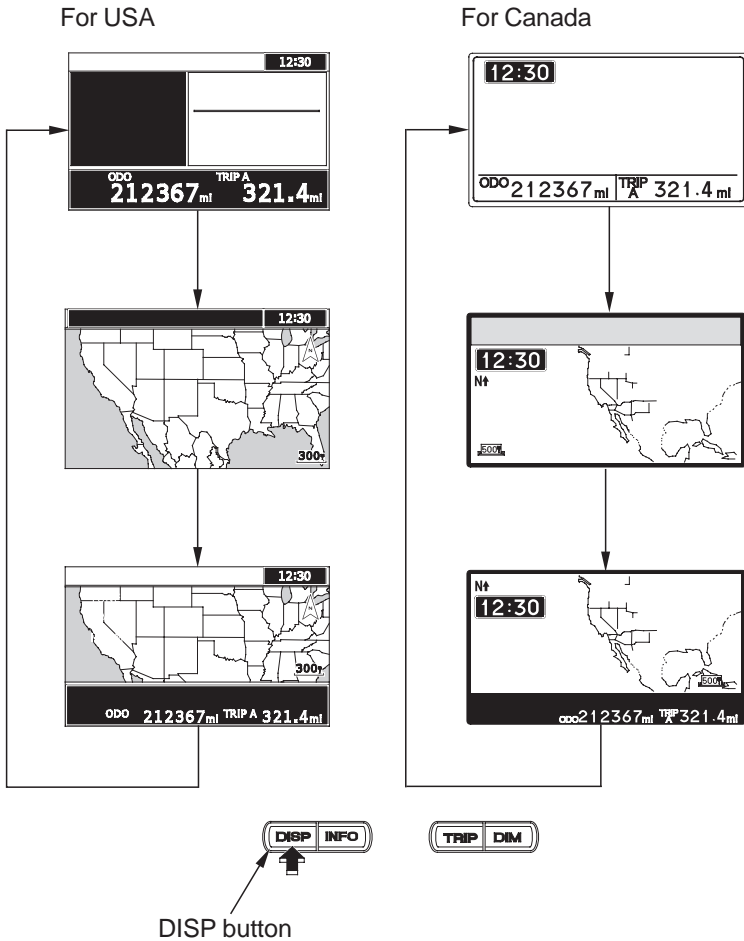

Multi Information Display

Changing the Information Display

The display changes as follows each time the INFO button is pushed.

When approximately 5 seconds pass without operating a button, the display automatically returns to the previous display.

(Models not equipped with Navigation System)

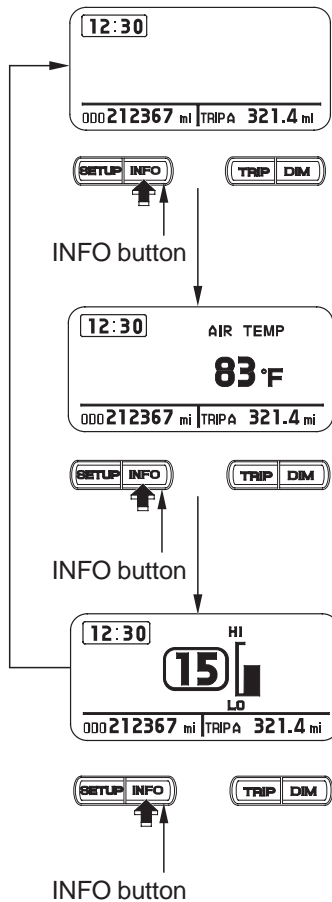

Multi Information Display

(Models equipped with Navigation System)

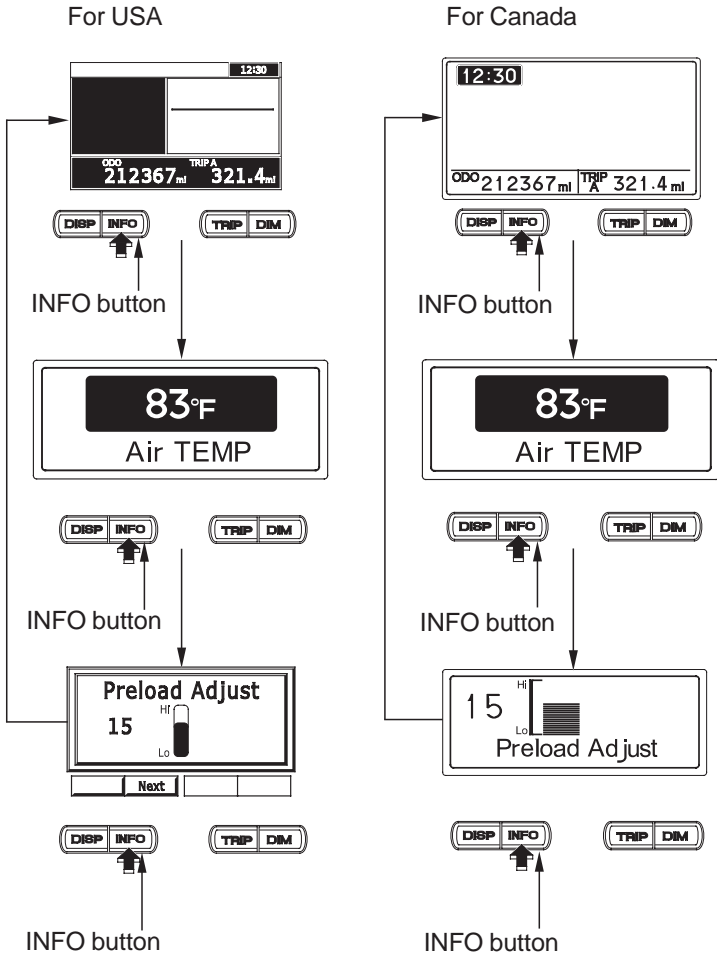

Controls & Features

Ignition Switch

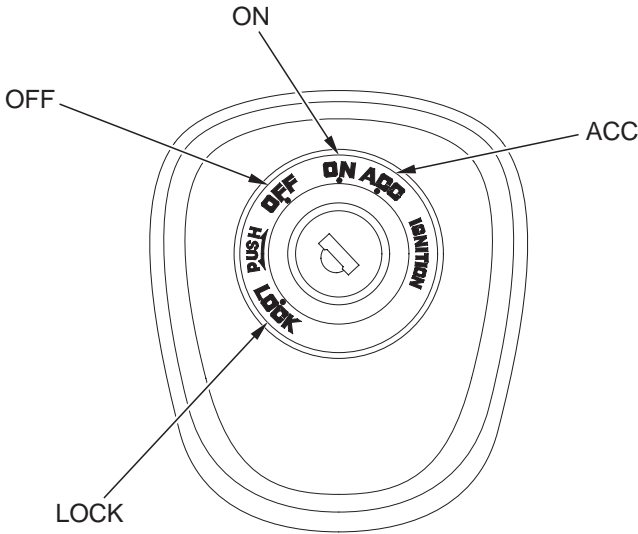

The ignition switch is used for starting and stopping the engine (page 73) and to lock the steering for theft prevention (page 89). Insert the key and turn it to the right for the ON and ACC (accessory) positions. Push down on the key and turn it to the left to the LOCK (steering lock) position.

Key Position	Function	Key Removal
ACC	Only the accessory circuits function.	cannot be removed
ON	Electrical circuits on.	cannot be removed
OFF	No electrical circuits function.	can be removed
LOCK (steering lock)	No electrical circuits function. Locks the steering head.	can be removed

To unlock the steering lock, insert and push down on the key and turn it to the right to the OFF position.

Controls & Features

Engine Stop Switch



RIGHT HANDLEBAR

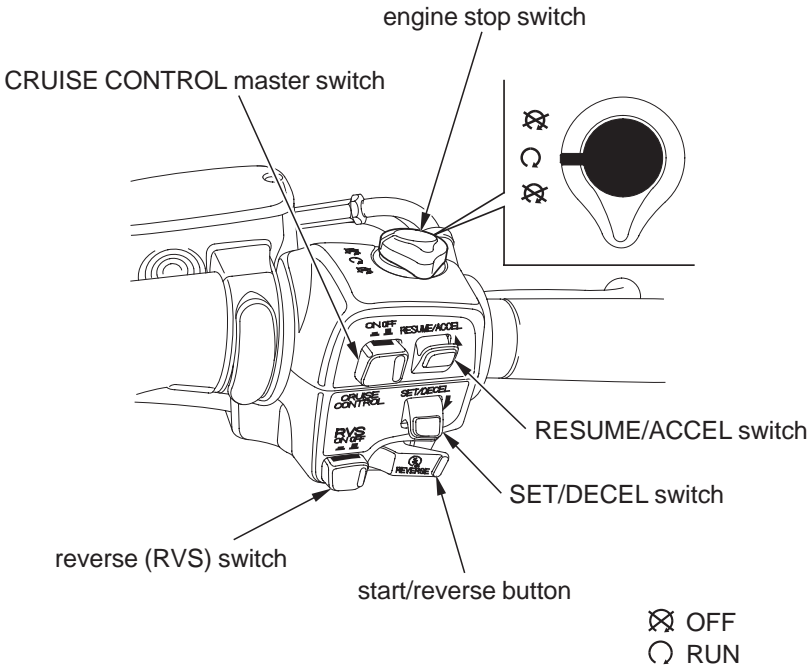

The engine stop switch is used to stop the engine in an emergency. To operate, turn the switch to the OFF position. The switch must be in the RUN position to start the engine, and it should normally remain in the RUN position even when the engine is OFF.

If your motorcycle is stopped with the ignition switch ON and the engine stop switch OFF, the headlight and taillight will remain on, resulting in battery discharge.

Start/Reverse Button



The start/reverse button is used for starting the engine. Pushing the start/reverse button starts the engine. See *Starting Procedure*, page 74 .

When the start/reverse button is pushed, the starter motor will crank the engine; the headlight will automatically go out, but the taillight will stay on.

The starter motor will not operate if the engine stop switch is in the OFF position when the start/reverse button is pushed.

The start/reverse button is also used for reverse riding. See *Riding in Reverse*, page 78 .

Reverse (RVS) Switch

The reverse switch is used to shift into reverse gear so you may back up your motorcycle. For instructions, see *Riding in Reverse*, page 78 .

Cruise Control Switches

Three switches are used to activate, adjust, and de-activate the cruise control system: a CRUISE CONTROL master switch, a SET/DECEL switch, and a RESUME/ACCEL switch. For operating instructions, see *Riding with Cruise Control*, page 93 .

Controls & Features

Headlight Dimmer Switch



The headlight dimmer switch is used to change between the high and low headlight beams. To operate, push the button to HI for high beam, LO for low beam.

Turn Signal Switch



The turn signal switch is used to signal a turn. To operate, move the switch all the way to the left or right and release it.

The appropriate turn signal lights will start blinking. The lights will automatically stop when you complete the turn. (You can manually cancel the lights by pushing the switch in.)

To signal a lane change, move the switch all the way to the left or right and release it. The turn signal lights will automatically stop in 7 seconds or after riding 110 yards (120 m).

Horn Button



The horn is used to alert other motorists. To operate, push the button.

Audio Control Switches

The audio control switches mounted on the left handlebar and above the fuel fill compartment are used to operate the radio. For specific features and operation instructions, see *Audio Systems*, page 97.

LEFT HANDLEBAR

audio control switches

headlight dimmer switch

turn signal switch

horn button

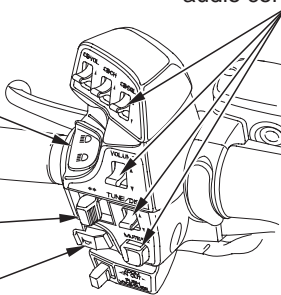

Controls & Features

Hazard Switch



The hazard switch is used to activate the hazard lights on your motorcycle if you need to stop near heavy traffic or if your motorcycle is disabled.

To operate, turn the ignition key to the ON or ACC position, and push the hazard switch. The front and rear turn signals will blink simultaneously until you push the switch again.

If you anticipate using the hazard system for an extended time, use the ACC position and turn off all unnecessary accessories to conserve battery capacity.

Be sure to turn the switch off when the hazard warning is no longer required, or the turn signals will not work properly and may confuse other drivers.

LEFT SIDE

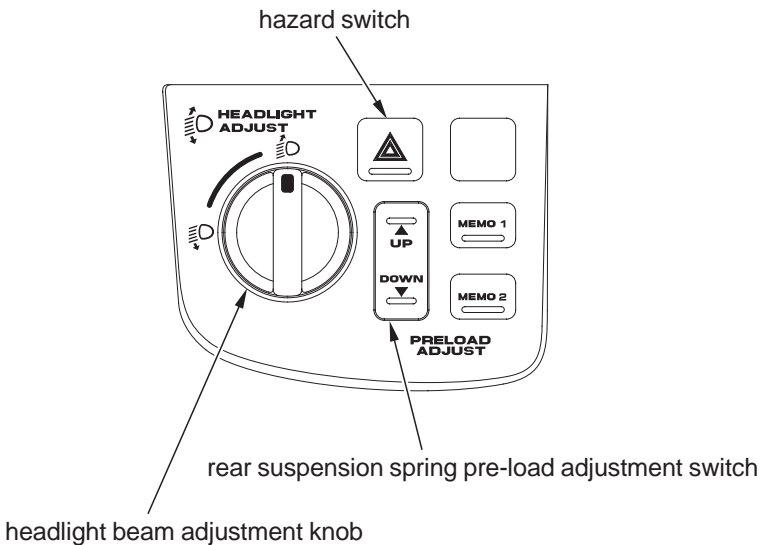

Controls & Features

Headlight Beam Adjustment Knob

The adjustment knob is used to raise or lower the height of the headlight beam. You may need to adjust the headlight if you change to a lighter or heavier load than you normally carry on your motorcycle.

If you carry a heavier or lighter than normal load, you may need to adjust your headlight beam so you can better see the road ahead and don't blind oncoming drivers. Obey local laws and regulations concerning headlight adjustment.

To operate, start the engine.

To lower the beam, turn the headlight beam adjustment knob counterclockwise.

To raise the beam, turn the knob clockwise.

Rear Suspension Spring Pre-load Adjustment Switch

The rear suspension spring pre-load adjustment switch is used to adjust the rear suspension to suit your load and riding conditions. For instructions on when and how to adjust the rear suspension, see *Rear Suspension Spring Pre-load Adjustment*, page 181.

Ventilation Controls

The windscreen ventilation louver is used to direct the flow of fresh air (page 64).

The side ventilation louvers and foot warmer ventilation louvers are used to direct the flow of warm air (pages 65, 66).

Windscreen Height Adjustment

The windscreen height adjustment levers are used to raise or lower your windscreen to suit your riding preference. For instructions, see page 63.

Before Riding

Before each ride, you need to make sure you and your Honda are both ready to ride. To help get you prepared, this section discusses how to evaluate your riding readiness, what items you should check on your motorcycle, and adjustments to make for your comfort, convenience, or safety. This section also includes important information about loading.

For information about adjusting the suspension on your Honda, see page 181.

Are You Ready to Ride?	44
Protective Apparel.....	44
Rider Training	46
Is Your Motorcycle Ready to Ride?	47
Pre-ride Inspection	47
Load Limits & Guidelines.....	49
Loading.....	49
Load Limits	50
Loading Guidelines	51
Cargo Compartment	52
Travel Trunk & Saddlebags.....	52
Remote Transmitter.....	56
Fairing Pockets	60
Trunk Side Pockets	61
Comfort & Convenience Adjustment.....	62
Windscreen Height Adjustment.....	63
Windscreen Ventilation Louver.....	64
Side Ventilation Louvers	65
Foot Warmer Ventilation Louvers.....	66
Handgrip Heater	67
Seat Heater	68
Accessories	69
Accessory (ACC) Terminal	69

Are You Ready to Ride?

Before you ride your motorcycle for the first time, we urge you to:

- Read this owner's manual.
- Make sure you understand all the safety messages.
- Know how to operate all the controls.

Before each ride, be sure:

- You feel well and are in good physical and mental condition.
- You are wearing an approved motorcycle helmet (with chin strap tightened securely), eye protection, and other protective clothing.
- You don't have any alcohol or drugs in your system.

Make sure your passenger is ready to ride, too, and is wearing proper gear including a helmet.

If you are not riding with a passenger and want to carry an extra helmet, use a commercially-available elastic cord, strap, or net to secure the helmet to the seat. The travel trunk may also be used to store an extra helmet.

Protective Apparel

For your safety, we strongly recommend that you always wear an approved motorcycle helmet, eye protection, boots, gloves, long pants, and a long-sleeved shirt or jacket whenever you ride.

Although complete protection is not possible, wearing proper gear can reduce the chance of injury when you ride.

Following are suggestions to help you choose the proper gear.

Are You Ready to Ride?

Helmet and Eye Protection

Your helmet is your most important piece of riding gear because it offers the best protection against head injuries. A helmet should fit your head comfortably and securely. A bright-colored helmet and reflective strips can make you more noticeable in traffic.

An open-face helmet offers some protection, but a full-face helmet offers more. Regardless of the style, look for a DOT (Department of Transportation) sticker on any helmet you buy (USA only). Always wear a face shield or goggles to protect your eyes and help your vision.

WARNING

Not wearing a helmet increases the chance of serious injury or death in a crash.

Be sure you and your passenger always wear a helmet, eye protection, and other protective apparel when you ride.

Additional Riding Gear

In addition to a helmet and eye protection, we also recommend:

- Sturdy boots with non-slip soles to help protect your feet and ankles.
- Leather gloves to help protect your hands.
- A motorcycle riding suit or jacket for comfort as well as protection. Bright-colored and reflective clothing can help make you more noticeable in traffic. Avoid loose clothes that could get caught on any part of your motorcycle.

Are You Ready to Ride?

Rider Training

Developing your riding skills is an on-going process. Even if you have ridden other motorcycles, take time to become familiar with how this motorcycle works and handles. Practice riding the motorcycle in a safe area to build your skills. Do not ride in traffic until you get accustomed to the motorcycle's controls, and feel comfortable with its size and weight.

We urge all riders to take a certified course approved by the Motorcycle Safety Foundation (MSF). New riders should start with the basic course, and even experienced riders will find the advanced course beneficial. For information about the MSF training course nearest you, call the national toll-free number: (800) 446-9227.

Other riding tips can be found in the *Riding Tips* booklet that came with your motorcycle (USA only).

Is Your Motorcycle Ready to Ride?

Before each ride, it's important to inspect your motorcycle and make sure any problem you find is corrected. A pre-ride inspection is a must, not only for safety, but because having a breakdown, or even a flat tire, can be a major inconvenience.

WARNING

Improperly maintaining this motorcycle or failing to correct a problem before riding can cause a crash in which you can be seriously hurt or killed.

Always perform a pre-ride inspection before every ride and correct any problems.

Pre-ride Inspection

Check the following items before you get on the motorcycle:

- | | |
|-----------------------------------|--|
| <i>Tires
&
Wheels</i> | Look at the tires. If a tire appears low, use an air pressure gauge to check its pressure. Also look for signs of excessive wear (page 191) or damage to the tires and wheels. |
| <i>Leaks,
Loose
Parts</i> | Walk around your motorcycle and look for anything that appears unusual, such as a leak or loose cable. |
| <i>Lights</i> | Make sure the headlight, brakelight, taillight, and turn signals are working properly. |

Is Your Motorcycle Ready to Ride?

If you are carrying a passenger or cargo, also check the following:

Load Limits Make sure you do not exceed the load limits (page 50).

Cargo Check that all cargo is secure.

Adjustments Adjust the rear suspension (page 180) according to your load.

Check these items after you get on the motorcycle:

Throttle Rotate the throttle to check it moves smoothly without binding.

Brakes Pull the brake lever and press on the brake pedal to check that they operate normally.

Indicators Turn the ignition on and check for normal operation of the indicators (page 16).

Gauges Check the fuel level and other gauges (page 16).

If you haven't ridden the motorcycle in over a week, you should also check other items, such as the oil level and other fluids. See *Periodic Maintenance* (page 143). Periodic maintenance should also be done at least once a month, no matter how often you ride.

Remember, be sure to take care of any problem you find, or have your Honda dealer correct it before you ride.

Load Limits & Guidelines

Your motorcycle has been designed to carry you and one passenger. When you carry a passenger, you may feel some difference during acceleration and braking. But so long as you keep your motorcycle well-maintained, with good tires and brakes, you can safely carry loads within the given limits and guidelines.

However, exceeding the weight limit or carrying an unbalanced load can seriously impair your motorcycle's handling, braking, and stability. Non-Honda accessories, improper modifications, and poor maintenance can also reduce your safety margin.

Loading

How much weight you put on your motorcycle, and how you load it, are important to your safety. Anytime you ride with a passenger or cargo, you should be aware of the following information.

WARNING

Overloading or improper loading can cause a crash and you can be seriously hurt or killed.

Follow all load limits and other loading guidelines in this manual.

Load Limits & Guidelines

Load Limits

Following are the load limits for your motorcycle:

maximum weight capacity: = 410 lbs (186 kg)
includes the weight of the rider, = 419 lbs (190 kg)
passenger, all cargo, and all accessories. (Canada only)

maximum cargo weight: = 71 lbs (32 kg)
includes following maximum compartment
weights:

travel trunk = 20.0 lbs (9.0 kg)

each saddlebag = 20.0 lbs (9.0 kg)

each fairing pocket
(Models not equipped with Airbag) = 4.5 lbs (2.0 kg)

fairing pocket
(Models equipped with Airbag) = 4.5 lbs (2.0 kg)

each trunk side pocket = 1.0 lbs (0.5 kg)

The weight of added accessories will reduce the maximum cargo weight you can carry.

Load Limits & Guidelines

Loading Guidelines

Improperly loading your motorcycle can affect its stability and handling. Even if your motorcycle is properly loaded, you should ride at reduced speeds and never exceed 80 mph (130 km/h) when carrying cargo.

Follow these guidelines whenever you carry a passenger or cargo:

- Check that both tires are properly inflated (page 190).
- If you change your normal load, you may need to adjust the rear suspension (page 180).
- To prevent loose items from creating a hazard, make sure that all cargo is tied down securely before you ride.
- Place cargo weight as low and close to the center of your motorcycle as possible.
- Balance cargo weight evenly on both sides.
- Make sure all cargo compartments are securely closed.
- Check the headlight beam adjustment if you change your normal load.
- Do not attach large or heavy items (such as a sleeping bag or tent) to the handlebar, forks, or fender.

Cargo Compartment

Your motorcycle comes with a lockable travel trunk and dual saddlebags, plus two trunk side pockets and front fairing pockets.

Instructions on how to open, close, and lock these compartments follow.

Travel Trunk & Saddlebags

The travel trunk and saddlebags are for lightweight items.

Cargo in the travel trunk and both saddlebags should not exceed:

20.0 lbs (9.0 kg) each

However, regardless of compartment capacity, be sure you do not exceed the maximum load and cargo weight limits (page 50).

To Lock & Unlock the Travel Trunk & Saddlebags

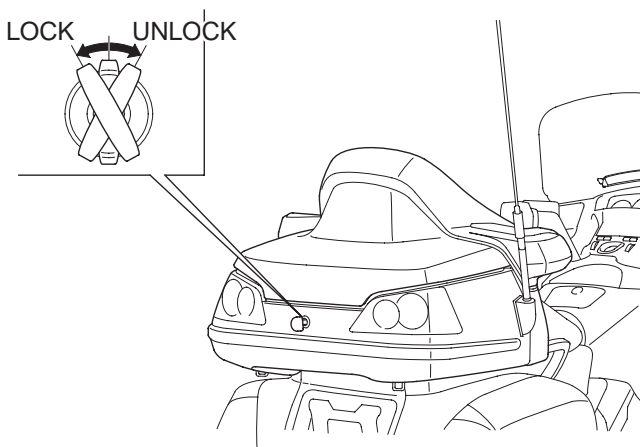

The travel trunk and saddlebags can be locked and unlocked with the ignition key or remote transmitter.

To use the remote transmitter, see page 56 .

To unlock:

Insert the ignition key and turn it clockwise.

To lock:

Insert the ignition key and turn it counterclockwise.

Cargo Compartment

To Open & Shut the Travel Trunk & Saddlebags

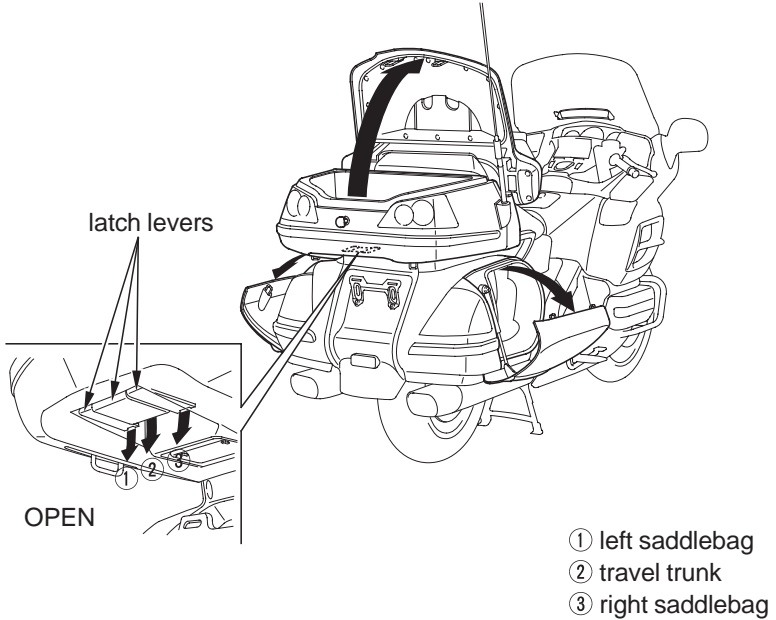

To open the travel trunk, pull the middle latch lever down.

To open the right or left saddlebag, pull the right or left latch lever down.

TO CLOSE:

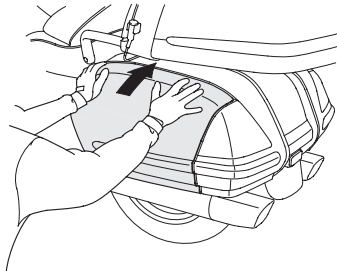

To shut each compartment, place your hands flat on the edges of its lid and press down until it is firmly closed and check the travel trunk & saddlebags open indicator is not displayed.

To lock the all compartments, use the ignition key or transmitter.

Cargo Compartment

If a Saddlebag Won't Open

REAR

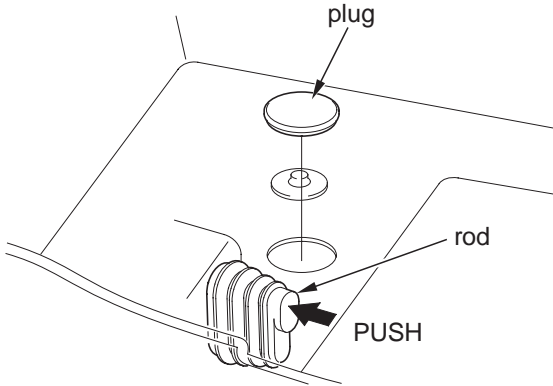

1. Open the travel trunk and remove the plug from the right or left access hole in the floor of the trunk.
2. Put your finger through the access hole and push the rod.
The saddlebag should open.

Cargo Compartment

Storage Box

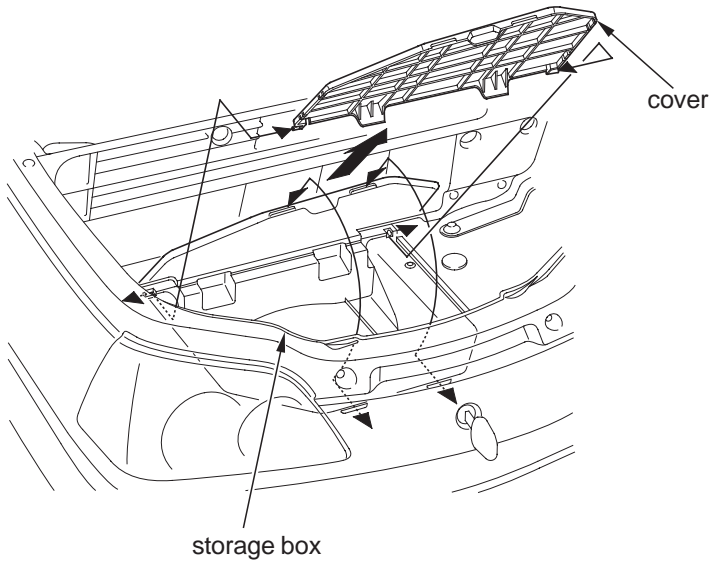

Your motorcycle has a storage box in the travel trunk. To open the storage box, push forward on the cover and raise it.

Cargo Compartment

Remote Transmitter

You can lock and unlock your motorcycle's trunk and saddlebags with the remote transmitter.

If the ignition switch is left off for more than one month, the remote transmitter will no longer operate the remote control system. To reset the system, turn the ignition switch ON.

- To lock the compartments — push the lock button.
(The front and rear turn signal lights will blink once.)

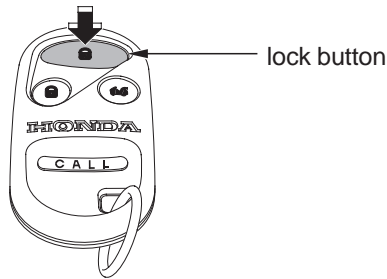

- To unlock the compartments — push the unlock button.
(The front and rear turn signal lights will blink two times.)

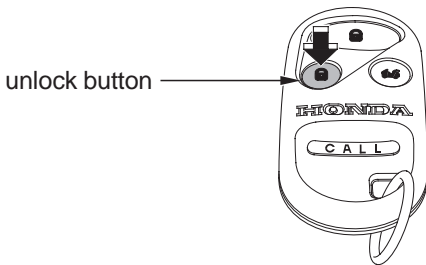

If you unlock the compartments with the transmitter, but do not open any of the compartments within thirty seconds, the compartments automatically relock.

You cannot lock the compartments with the remote transmitter if any compartment is not fully closed. (The front and rear turn signal lights will blink ten times.)

Cargo Compartment

- To open the trunk, push and hold the trunk release button for approximately one second.

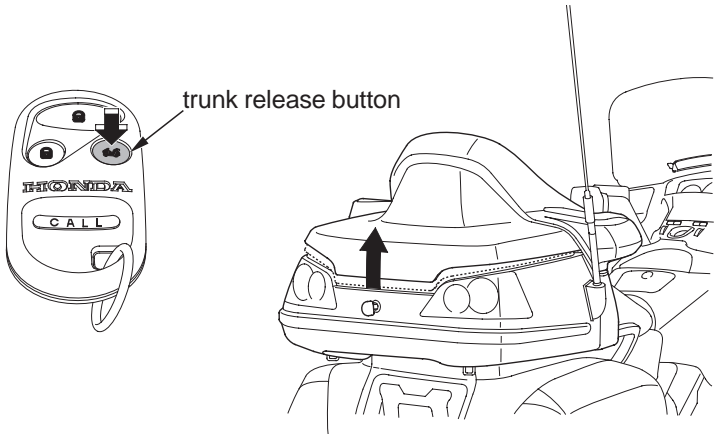

Call Mode

The call mode is provided to let you locate your motorcycle when it is parked in a large lot.

Push and hold the CALL button, the horn will sound and the turn signal lights will blink two times.

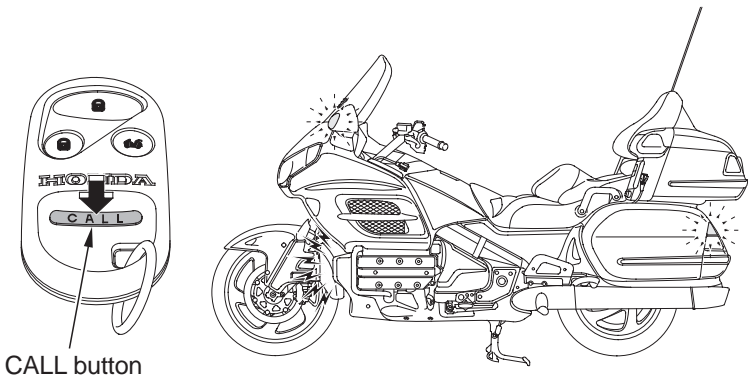

When the ignition switch is in the ON or ACC position:

- You can lock and unlock the compartments.
- The trunk release button will not operate.
- The call mode will not operate.

Cargo Compartment

Replacing the Battery

When the remote transmitter's battery begins to get weak, it may take several pushes on the button to lock or unlock the compartments, and the LED will get dim. Replace the battery as soon as possible.

Battery type: CR2025

Recycle or dispose of batteries properly, according to local regulations. Improper battery disposal can harm the environment.

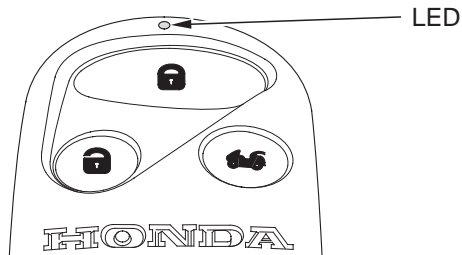

1. Use a coin to turn the round cover on the back of the transmitter counterclockwise.
2. Remove the old battery and note the polarity. Make sure the polarity of the new battery is the same (+ side facing up), then insert it in the transmitter.
3. Align the ∇ mark on the cover with the \odot mark on the transmitter, then set the cover in place and turn it clockwise.

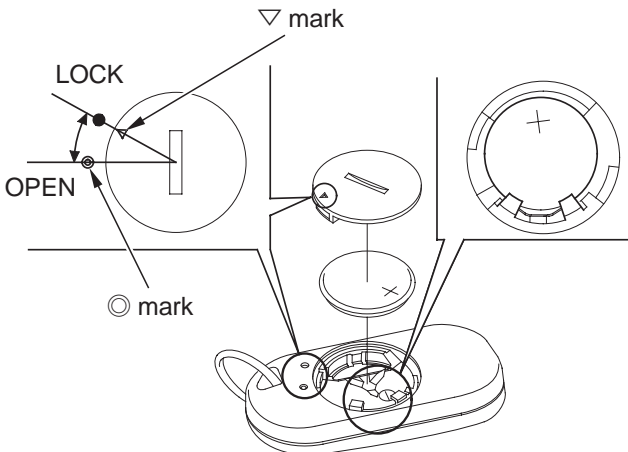

Cargo Compartment

Transmitter Care

Avoid severe shock to the transmitter, such as dropping or throwing it. Also, protect it from extreme hot or cold temperatures.

Clean the transmitter case with a soft cloth. Do not use strong cleaners or solvents that could harm the case. Immersing the transmitter in any liquid will harm the transmitter and cause it to not function properly.

If you lose a transmitter, you will need to have the replacement programmed to your motorcycle's system by your Honda dealer. Any other transmitters you have will also need to be reprogrammed.

As required by the FCC:

This device complies with Part 15 of the FCC rules. Operation is subject to the following two conditions: (1) This device may not cause harmful interference, and (2) this device must accept any interference received, including interference that may cause undesired operation.

Changes or modifications not expressly approved by the party responsible for compliance could void the user's authority to operate the equipment.

This device complies with Industry Canada Standard RSS-210. Operation is subject to the following two conditions: (1) this device may not cause interference, and (2) this device must accept any interference that may cause undesired operation of the device.

Cargo Compartment

Fairing Pockets

LEFT SIDE

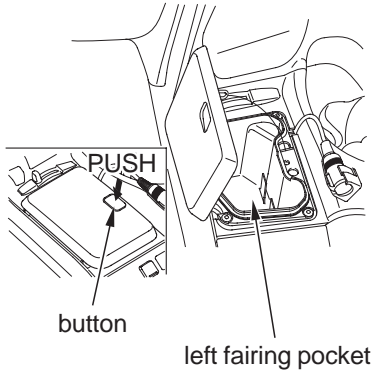

(Models not equipped with Airbag)
RIGHT SIDE

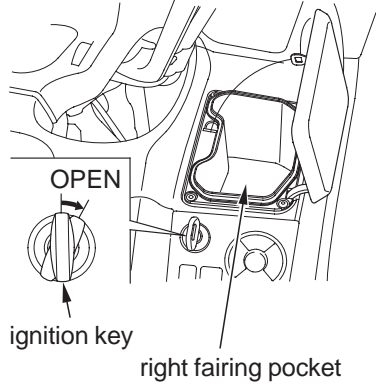

The fairing pockets are for lightweight items.
Cargo in each fairing pocket should not exceed:
4.5 lbs (2.0 kg)

To open the left fairing pocket, push the button.

(Models not equipped with Airbag)

To open the right fairing pocket, insert the ignition key, turn it clockwise.

To close the fairing pocket, place your hands flat on the edges of its lid and press down until it is firmly closed.

Make sure the fairing pockets are closed before riding.

Be careful not to flood this area when washing your motorcycle.

Take care to keep gasoline, brake fluid, or other chemical solvents off the pocket covers. They will damage the surface of the pocket covers.
Do not store valuables in the fairing pockets.

Cargo Compartment

Trunk Side Pockets

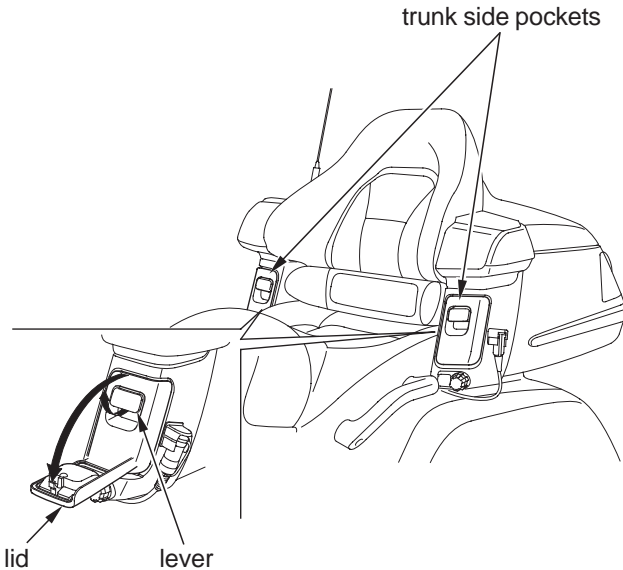

The trunk side pockets are for soft, lightweight items.

Cargo in each trunk side pocket should not exceed:

1.0 lbs (0.5 kg)

Do not put sharp or hard objects in the trunk side pockets. Such objects could interfere with opening the lids or damage the pockets.

To open the lid, pull the lever up.

To close the lid, pull the lid up. Check that latch is secure.

Make sure the trunk side pockets are closed before riding.

Be careful not to flood this area when washing your motorcycle.

Comfort & Convenience Adjustment

Your motorcycle has many features you can adjust to suit your personal preference and increase your comfort and convenience, and your passenger's as well.

We recommend that you take time to check the following items and make any desired adjustments before each ride:

Suspension The rear suspension spring pre-load (page 181) can be adjusted for a softer or firmer ride using an electrical adjustment system. You may want to adjust your suspension whenever you change your normal load.

Windscreen Height Your windscreen height can be adjusted slightly higher or lower (page 63).

Ventilation Louvers If you need to adjust the ventilation louvers (pages 64 – 66), do it before you ride.

Handgrip Heater The range of the handgrips heater can be adjusted higher or lower (page 67).
Make sure the handgrip heater switch moves easily over the full adjustment range.
Select the heat level you want before your ride (with the engine running).

Seat Heater The range of the seat heater can be adjusted higher or lower (page 68).
Make sure the seat heater switch moves easily over the full adjustment range.
Select the heat level you want before your ride (with the engine running).

Comfort & Convenience Adjustment

Windscreen Height Adjustment

The windscreen adjuster has 6 positions.

You can adjust your windscreen height slightly higher or lower.

If possible, we recommend you adjust your windscreen height to below eye level for better visibility.

To Adjust Windscreen Height

FRONT

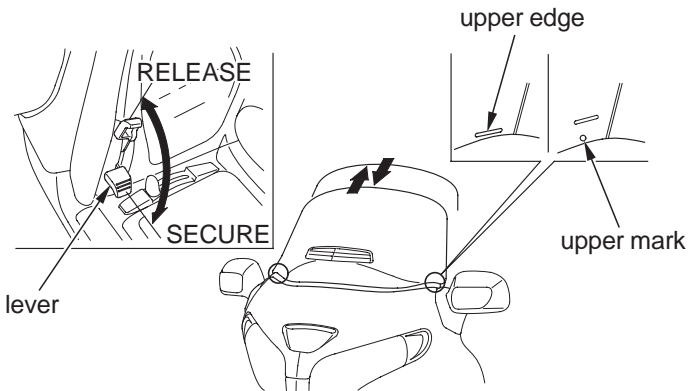

1. Pull both levers up to release the windscreen.
2. To raise:
Move the windscreen up to the desired position.
To lower:
Move the windscreen up to the upper mark (○), lower it all the way (to reset the ratchet mechanism), then raise it to the desired position.
3. On both sides, align the mark on the windscreen with the upper edge of the instrument panel.
4. Push the levers down to secure the windscreen.

Comfort & Convenience Adjustment

Windscreen Ventilation Louver

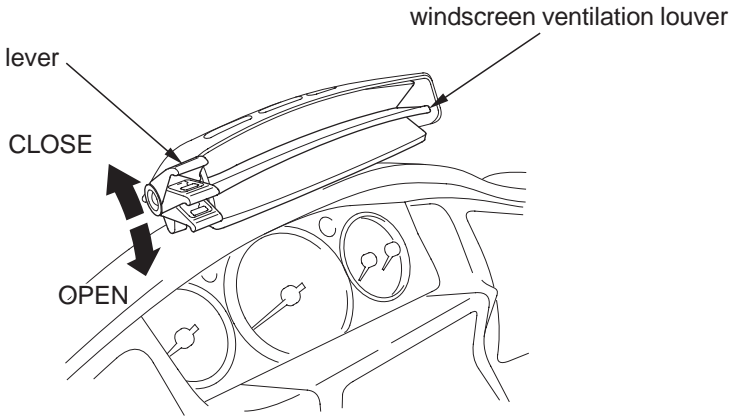

You can adjust the windscreen ventilation louver with the lever to control and direct the flow of fresh air.

Comfort & Convenience Adjustment

Side Ventilation Louvers

LEFT SIDE

RIGHT SIDE

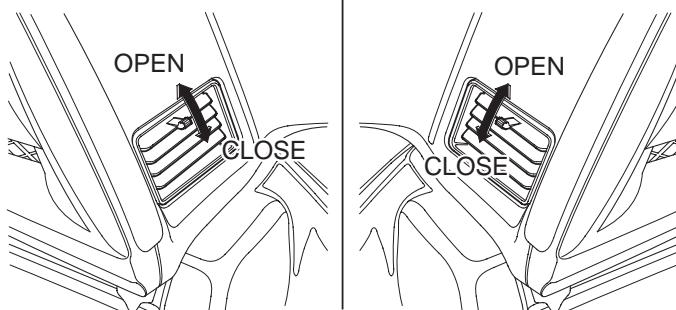

You can adjust the side ventilation louvers to direct the flow of air.

Comfort & Convenience Adjustment

Foot Warmer Ventilation Louvers

(Models equipped with Comfort Package)

LEFT UPPER

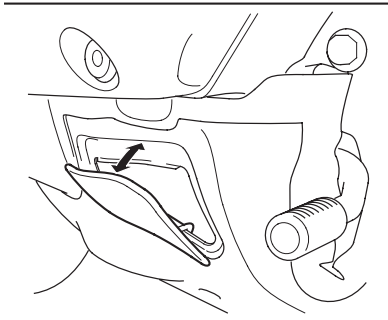
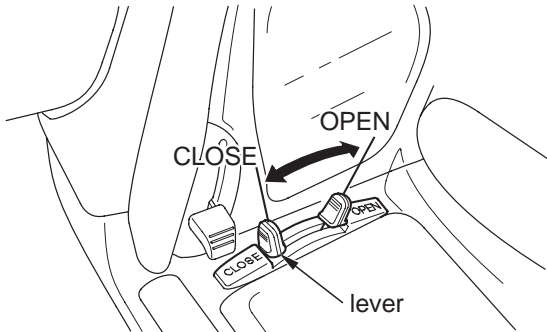

LEFT SIDE

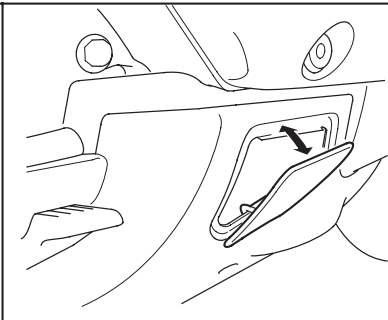

RIGHT SIDE

You can adjust the foot warmer ventilation louvers with the lever to control and direct the flow of warm air.

Comfort & Convenience Adjustment

Handgrip Heater

(Models equipped with Comfort Package)

The handgrip heater warms up the right and left handgrips of the handlebar for comfortable riding on a cold day.

The handgrip heater switch is located on the right side of the ignition switch. To operate, adjust the handgrip heater switch with the engine started. The handgrip heater switch has 6 positions (OFF, 1, 2, 3, 4, MAX).

RIGHT SIDE OF THE IGNITION SWITCH

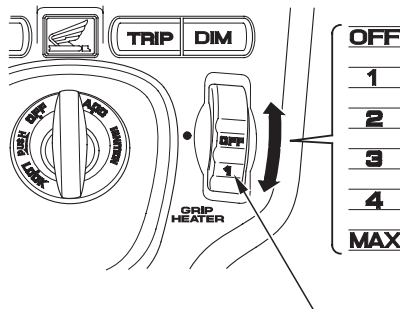

handgrip heater switch

To warm up the handgrip heaters, turn the handgrip heater switch toward the MAX position.

To cool down the handgrip heaters, turn the handgrip heater switch toward the OFF position.

Do not leave the handgrip heater in the high position for a long time on a warm day.

Wear gloves to protect your hands from the heated grips.

Do not use the handgrip heater with the engine at idle for a long time. It may result in a low (or dead) battery.

Comfort & Convenience Adjustment

Seat Heater

(Models equipped with Comfort Package)

The seat heater warms up the driver's seat (and the passenger's seat) for comfortable riding on a cold day.

The front seat heater switch is located on the left side of the ignition switch.

The rear seat heater switch is located under the left trunk side pocket.

To operate, adjust the seat heater switch with the engine started.

The front and rear seat heater switches have 6 positions (OFF, 1, 2, 3, 4, MAX).

LEFT SIDE OF THE IGNITION SWITCH

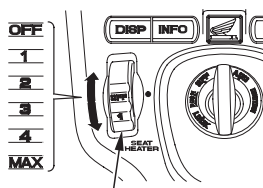

front seat heater switch

UNDER THE LEFT TRUNK SIDE POCKET

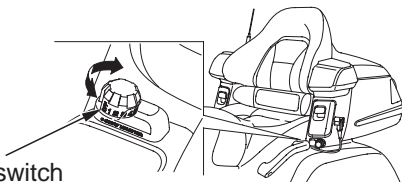

rear seat heater switch

To warm up the seat heater, turn the seat heater switch toward the MAX position.

To cool down the seat heater, turn the seat heater switch toward the OFF position.

Do not leave the seat heater in the high position for a long time on a warm day.

Do not use the seat heater with the engine at idle for a long time. It may result in a low (or dead) battery.

Do not use the seat heater when the seat is torn, cut or damaged as you can get burned.

Do not apply excessive stress to the seat, e.g. by securing articles to it with tie-down straps during transportation.

Accessory (ACC) Terminal

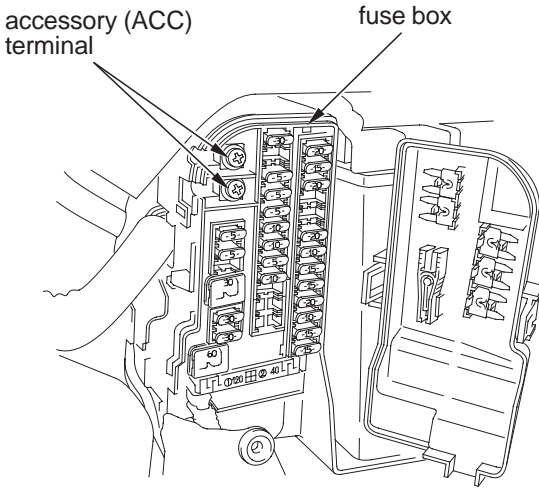

For your convenience, your motorcycle is equipped with an accessory (ACC) terminal and optional accessory socket. The terminal and socket provide 12V DC power for electrical accessories. When both terminal and socket are being used, the combined power rating of each accessory should be 60 watts (5 amps) or less. Before installing any accessories, read *Accessories and Modifications*, page 4.

If you install any accessories, check the battery frequently to determine the state of charge. Higher current demands may blow a fuse or discharge the battery. For more information, see *Battery*, page 197, and *If a Fuse Blows*, page 232.

Connect accessory electrical leads securely, and keep them insulated, away from hot parts and sharp edges.

Basic Operation & Riding

This section gives basic riding instructions, including how to start and stop your engine, and how to use the throttle, clutch, and brakes. It also provides important information on riding with a passenger or cargo, and operating your cruise control.

To protect your new engine and enjoy optimum performance and service life, refer to Break-in Guidelines (page 248).

To protect the catalytic converters in your motorcycle's exhaust system, avoid extended idling and the use of leaded gasoline.

Safe Riding Precautions	72
Starting & Stopping the Engine	73
Preparation.....	73
Starting Procedure	74
Flooded Engine	74
Bank Angle Sensor Ignition Cut-off System	75
How to Stop the Engine	75
Shifting Gears.....	76
While You Are Riding	77
Riding in Reverse	78
Braking	80
Anti-Lock Brake System (ABS).....	82
ABS Indicator Light.....	83
Tire Pressure Monitoring System (TPMS).....	85
Low Tire Pressure Indicator.....	86
Tire Pressure Monitoring System (TPMS) Indicator	87
Changing a Tire with TPMS	88
Parking.....	89
Theft-prevention Tips	91
Riding with a Passenger or Cargo.....	92
Riding with Cruise Control	93
Cruise Control	93
To Set Cruise Control.....	94
To Change the Set Speed	94
To Cancel Cruise Control	95
Riding in Bad Weather.....	96

Safe Riding Precautions

Before riding your motorcycle for the first time, please review the *Motorcycle Safety* section beginning on page 1, and the *Before Riding* section beginning on page 43.

Even if you have ridden other motorcycles, take time to become familiar with how this motorcycle works and handles. Practice in a safe area until you build your skills and get accustomed to the motorcycle's size and weight.

Make sure flammable materials such as dry grass or leaves do not come in contact with the exhaust system when riding, idling, or parking your motorcycle.

Starting & Stopping the Engine

Always follow the proper starting procedure described below.

For your safety, avoid starting or operating the engine in an enclosed area such as a garage. Your motorcycle's exhaust contains poisonous carbon monoxide gas which can collect rapidly in an enclosed area and cause illness or death.

Your motorcycle can be started with the transmission in gear by pulling in the clutch lever before operating the starter.

Your motorcycle is equipped with a side stand ignition cut-off system. If the side stand is down — the engine cannot be started unless the transmission is in neutral. If the side stand is up — the engine can be started in neutral, or in gear with the clutch lever pulled in. After starting with the side stand down, the engine will stop if the transmission is put in gear before raising the side stand.

Preparation

Before starting, insert the key, turn the ignition switch ON, and confirm the following:

- The transmission is in neutral (neutral indicator is ON).
- The engine stop switch is set to RUN.
- The low oil pressure indicator is ON.
- The PGM-FI malfunction indicator lamp (MIL) is OFF.
- The ABS indicator light is ON (models equipped with ABS).
- The airbag indicator is OFF (models equipped with Airbag).

The low oil pressure indicator and airbag indicator (models equipped with Airbag) should go off a few seconds after the engine starts. If the low oil pressure indicator lights during operation, stop the engine immediately and check the engine oil level.

If the airbag indicator stays on or lights during operation, have your motorcycle inspected as soon as possible by an authorized Honda dealer (models equipped with Airbag).

Starting & Stopping the Engine

Starting Procedure

This motorcycle has a fuel-injected engine with an automatic fast idle. Follow the procedure indicated below.

Any Air Temperature

- Press the start button with the throttle completely closed.

The engine will not start if the throttle is fully open (because the electronic control module cuts off the fuel supply).

Flooded Engine

If the engine fails to start after repeated attempts, it may be flooded with excess fuel. To clear a flooded engine:

1. Leave the engine stop switch set to RUN.
2. Open the throttle fully.
3. Press the start button for 5 seconds.
4. Follow the normal starting procedure.
5. If the engine starts, then open the throttle slightly if idling is unstable.
If the engine does not start, wait 10 seconds, then follow steps 1 – 4 again.

If the engine still won't start, refer to *If Your Engine Quits or Won't Start*, page 215 .

Starting & Stopping the Engine

Bank Angle Sensor Ignition Cut-off System

Your motorcycle's banking (lean angle) sensor system is designed to automatically stop the engine and fuel pump if the motorcycle is overturned.

Before restarting the engine, you must turn the ignition switch to the OFF position and then back to ON. The engine will not restart until you perform this procedure.

How to Stop the Engine

Normal Engine Stop

To stop the engine, shift into neutral and turn the ignition switch OFF.

The engine stop switch should normally remain in the RUN position even when the engine is OFF.

If your motorcycle is stopped with the ignition switch ON and the engine stop switch OFF, the headlight and taillight will remain on, resulting in battery discharge.

Emergency Engine Stop

To stop the engine in an emergency, use the engine stop switch. To operate, turn the switch to the OFF position.

Shifting Gears

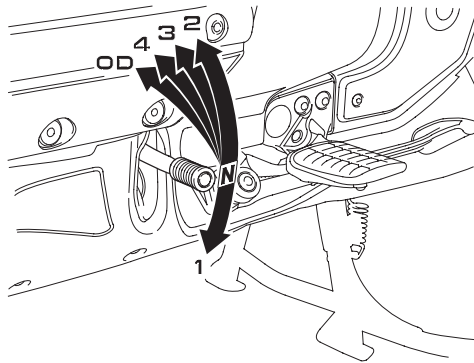

Your motorcycle has five forward gears in a one-down, four-up shift pattern which is coordinated with a hydraulically actuated clutch system.

Learning when to shift gears comes with experience. Keep the following tips in mind:

- As a general rule, shift while moving in a straight line.
- Close the throttle and pull the clutch lever in completely before shifting. Improper shifting may damage the engine, transmission, and drive train.
- Learn to recognize the engagement point as you release the clutch lever. It is at this point the transmission of power to the rear wheel resumes.
- Upshift to a higher gear or reduce throttle before engine rpm (speed) gets too high. Learn the relationship between engine sound and the normal shifting points.
- Downshift to a lower gear before you feel the engine laboring (lugging) at low rpm.
- Avoid downshifting to help slow your motorcycle when engine rpm is near its allowable maximum (near the tachometer red zone). In this situation, the rev limiter in the engine ignition control module may not prevent excessive engine speed which could damage the engine.
- To prevent transmission damage, do not coast or tow the motorcycle for long distances with the engine off.

Shifting Gears

Recommended Shift Points

Ride in the highest gear that lets the engine run and accelerate smoothly. This will give you good fuel economy and effective emissions control. When changing gears under normal conditions, use these recommended shift points:

Shifting Up:

From 1st to 2nd:	12 mph (20 km/h)
From 2nd to 3rd:	19 mph (30 km/h)
From 3rd to 4th:	25 mph (40 km/h)
From 4th to OD:	31 mph (50 km/h)

Shifting Down:

From OD to 4th:	22 mph (35 km/h)
From 4th to 3rd:	16 mph (25 km/h)

Pull the clutch lever in when speed drops below 12 mph (20 km/h), when engine roughness is evident, or when engine stalling is imminent; and shift down to 1st gear for acceleration.

While You Are Riding

While you are riding, occasionally check your gauges and indicators. Continuing to ride with the low oil pressure indicator (red) on or the coolant temperature gauge needle at the H (hot) mark can cause serious engine damage. Also keep an eye on the fuel gauge and the low fuel indicator.

Riding in Reverse

Your motorcycle's reverse system allows you to back out of a parking position at slow speed.

Make sure there are no obstacles or people in the area. Avoid steep or uneven surfaces. Carrying a passenger while reversing is not recommended because it makes balance and control more difficult to maintain.

1. Sit astride the motorcycle, in your normal riding position, with both feet on the ground.
2. Make sure the transmission is in neutral (neutral indicator is ON) and the side stand is up.
3. Start the engine. (Make sure the RVS switch is OFF.)
4. Push the RVS switch to ON, then make sure the reverse system indicator comes on.

RIGHT HANDLEBAR

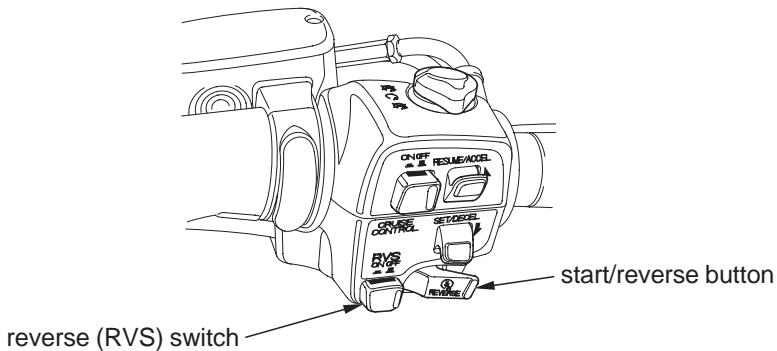

5. When you are ready to back up, push the start/reverse button and hold it in. The motorcycle will move in reverse as long as you hold the button in. To prevent battery discharge, do not push the start/reverse button more than a minute.
6. Guide the motorcycle backward cautiously, using your legs to maintain balance. Use extreme care to maintain balance while reversing on loose surfaces (sand, dirt, gravel) or grease-covered pavement.

Riding in Reverse

7. Release the start/reverse button, and the motorcycle will stop.
8. After your motorcycle is stopped, push the RVS switch to OFF. Make sure the reverse gear indicator goes off and the neutral indicator comes on.

NOTICE

To avoid damaging the reverse system, do not engage or disengage reverse when the motorcycle is moving.

If the reverse switch is in the ON position with the engine off, the engine cannot be started.

Reverse System Overload

The reverse system is designed to move the motorcycle at a constant slow speed. If the motorcycle begins moving slower or faster than this speed, because of obstacles or a steep pavement angle, the system will shut off and the reverse system indicator will turn OFF.

To resume reverse operation or normal forward operation, push the RVS switch to the OFF position and carefully roll the motorcycle to a more level, unobstructed surface, then start again.

Braking

Your motorcycle is equipped with a Linked Braking System. Operating the front brake lever applies the front brake and a portion of the rear brake. Operating the rear brake pedal applies the rear brake and a portion of the front brake. For full braking effectiveness, use both the lever and pedal simultaneously, as you would with a conventional motorcycle braking system.

To slow or stop, apply the brake lever and brake pedal smoothly, while downshifting to match your speed.

Gradually increase braking as you feel the brakes slowing your speed. The increase in engine compression from downshifting will help slow your motorcycle.

To prevent stalling the engine, pull the clutch lever in before coming to a complete stop. For support, put your left foot down first, then your right foot when you have finished braking.

When possible, reduce your speed or complete braking before entering a turn. Avoid braking or closing the throttle quickly while turning. Either action may cause one or both wheels to slip and reduce your control of your motorcycle.

Your ability to brake in a turn and to brake hard in an emergency situation are important riding skills. We suggest attending a Motorcycle Safety Foundation experienced rider training course (page 46) to retain these skills.

When riding in wet or rainy conditions, or on loose surfaces, the ability to maneuver and stop will be reduced. All of your actions should be smooth under these conditions. Rapid acceleration, braking or turning may cause loss of control.

For your safety, exercise extreme caution when braking, accelerating or turning.

When descending a long, steep grade, use engine compression braking by downshifting, with intermittent use of both brakes. Continuous brake application can overheat the brakes and reduce their effectiveness.

Braking

Riding with your foot resting on the brake pedal or your hand on the brake lever may actuate the brakelight, giving a false indication to other drivers. It may also overheat the brakes, reducing effectiveness.

(Models not equipped with ABS)

As with a conventional motorcycle braking system, excessively hard application of the brake controls may cause wheel lock, reducing control of the motorcycle.

Applying the brakes too hard may cause the wheels to lock and slide, reducing control of your motorcycle. If this happens, release the brake controls, steer straight ahead until you regain control, then reapply the brakes more gently.

Braking

Anti-Lock Brake System (ABS)

(Models equipped with ABS)

This model is also equipped with an Anti-lock Brake System (ABS) designed to help prevent wheel lock up during hard braking on uneven or other poor surfaces while running straight. Although the wheel may not lock up—if you are braking too hard in a turn the motorcycle can still lose traction, causing a loss of control.

In some situations, a motorcycle with ABS may require a longer stopping distance to stop on loose or uneven surfaces than an equivalent motorcycle without ABS.

ABS cannot make up for road conditions, bad judgment, or improper operation of the brakes. It is still your responsibility to ride at reasonable speeds for weather, road surface, and traffic conditions, and to leave a margin of safety.

ABS is self-checking and is always on.

ABS may also be activated by braking while riding over a sharp drop or rise in the road level.

It is important to follow the tire recommendations (see page 195). The ABS computer works by comparing wheel speed.

Non-recommended tires can affect wheel speed and may confuse the ABS computer.

ABS does not function at very low speeds (approximately 5 mph (8 km/h) or below).

ABS does not function if the battery is discharged.

ABS Indicator Light

(Models equipped with ABS)

Normally, this light comes on when the ignition is turned ON and goes off after starting to ride. If there is an ABS problem, the indicator light comes on and remains on or blinks. The ABS system does not operate when the ABS indicator light is on or blinking.

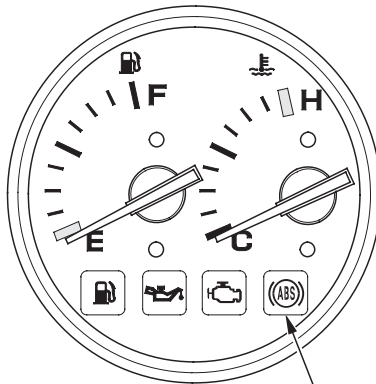

ABS indicator light

Braking

If the ABS indicator light blinks while riding, stop the motorcycle in a safe place and turn off the engine. Turn the ignition ON again. The light should come on, and then go off after starting to ride. If it does not go off or if it blinks again, ABS is not functioning.

However, the Linked Braking System will still provide normal stopping ability, but you should have the ABS system checked by your Honda dealer as soon as possible.

The ABS indicator may blink if you place the motorcycle on its center stand and turn the rear wheel. This is normal. Turn the ignition OFF to stop the blinking.

A red LED is used for the ABS indicator light. Be sure that the LED lights when the ignition is ON. If the LED fails to light, see your Honda dealer.

Tire Pressure Monitoring System (TPMS)

Your motorcycle is equipped with a tire pressure monitoring system (TPMS) that turns on every time you start the engine and it monitors the pressure in your tires while riding.

Each tire has its own pressure sensor. If the air pressure of a tire becomes significantly low while riding, the sensor in that tire sends a signal that causes the low tire pressure indicator to turn on.

As required by the FCC (USA only):

This device complies with Part 15 of the FCC rules. Operation is subject to the following two conditions: (1) This device may not cause harmful interference, and (2) this device must accept any interference received, including interference that may cause undesired operation.

Changes or modifications not expressly approved by the party responsible for compliance could void the user's authority to operate the equipment.

This device also complies with Industry Canada Standard RSS-210.

Operation is subject to the following two conditions: (1) this device may not cause interference, and (2) this device must accept any interference that may cause undesired operation of the device.

Tire Pressure Monitoring System (TPMS)

Low Tire Pressure Indicator

If the low tire pressure indicator flashes, check your tires as soon as possible. If the low tire pressure indicator lights constantly, one or more of your tires is significantly underinflated. You should stop and check your tires as soon as possible. For more information on temporary repair, see *If You Have a Flat Tire* on page 218.

Check the air pressure when the tires are cold. This means the motorcycle has been parked for at least 3 hours. Add or release air, if needed, to match the recommended cold tire pressures on page 190.

When the low tire pressure indicator flashes or lights, but you continue to ride, the low tire pressure indicator will go off in some cases. It is still necessary to check the air pressures of both tires after the tires cool. Air in the tires is expanded with heat.

If the low tire pressure indicator does not turn off after inflating the tires to the specified values, have your Honda dealer to check the system as soon as possible.

Riding on a underinflated tire causes the tire to overheat and can lead to tire failure.

Under-inflation also reduces fuel efficiency and tire tread life, and may affect the motorcycle's handling and stopping ability.

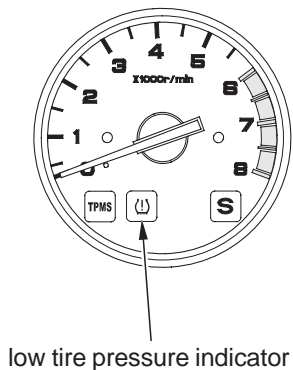

Tire Pressure Monitoring System (TPMS)

Because tire pressure varies by temperature and other conditions, the low tire pressure indicator may turn on unexpectedly.

Please note that the TPMS is not a substitute for proper tire maintenance, and it is the rider's responsibility to maintain correct tire pressure, even if underinflation has not reached the level of turning on the low tire pressure indicator.

For example, if you check and fill your tires in a warm area, then ride in extremely cold weather, the tire pressure will be lower than measured and could be underinflated and cause the low tire pressure indicator to turn on. Or, if you check and adjust your tire pressure in cooler conditions, and ride into extremely hot conditions, the tire may become overinflated. However, the low tire pressure indicator will not turn on if the tires are overinflated.

Tire Pressure Monitoring System (TPMS) Indicator

The tire pressure monitoring system (TPMS) indicator comes on and stays on if there is a problem with the tire pressure monitoring system.

If this happens, the system will shut off and no longer monitor tire pressure.

Have the system checked by your Honda dealer as soon as possible.

Also the TPMS indicator may light for the following reasons:

- Interference of other electronic devices by using the same radio frequency.
- Using replacement wheels not equipped with tire pressure sensors.

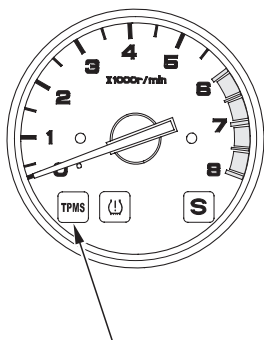

tire pressure monitoring system (TPMS) indicator

Tire Pressure Monitoring System (TPMS)

Changing a Tire with TPMS

Each wheel is equipped with a tire pressure sensor mounted inside the tire behind the valve stem. You must use TPMS specific wheels. Always have your tires serviced by your Honda dealer.

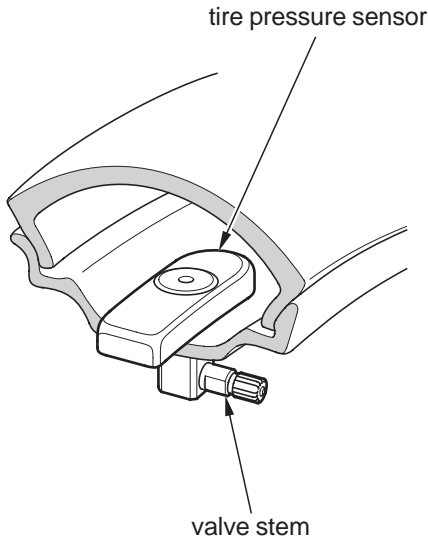

NOTICE

Using a puncture-repairing agent can damage the TPMS sensors, causing the TPMS indicator to turn on. Have your motorcycle checked by your Honda dealer as soon as possible.

Use caution to not damage the TPMS sensor if an internal plug patch must be used to repair the tire. If you have a tire professionally repaired at a non-Honda facility, we recommend that you have the work checked by your Honda dealer. TPMS wheels require special handling when changing the tire. Failure to follow the proper tire replacement procedure can result in damage to the TPMS sensor.

Parking

1. Look for a level parking area. If you can't park on a paved surface, make sure the ground surface is firm.

If you must park on a hill, leave the transmission in gear and position the rear tire against the curb at a 45 degree angle.

Make sure flammable materials such as dry grass or leaves do not come in contact with the exhaust system when parking your motorcycle. Refer to *Catalytic Converters*, page 255 .

2. Use the side or center stand to support the motorcycle while parked.

- To lower the side stand, use your foot to guide it down. Remember that lowering the side stand with the transmission in gear will stop the engine, even if the clutch lever is pulled in. That is a function of the side stand ignition cut-off system.

- Check that the side stand is down all the way. The side stand indicator only indicates that the side stand ignition cut-off system (page 73) is activated.

- To lower the center stand, stand on the left side of the motorcycle. Hold the passenger handgrip attached to the seat. Press down on the tip of the stand with your right foot and, simultaneously, pull up and back on the passenger handgrip.

3. Use the steering lock, which locks the handlebar in place. Turn the handlebar all the way to the left or right. Push in on the ignition key and turn it to LOCK. Remove the key.

(To unlock the steering lock, insert and push down on the key and turn it to the right to the OFF position.)

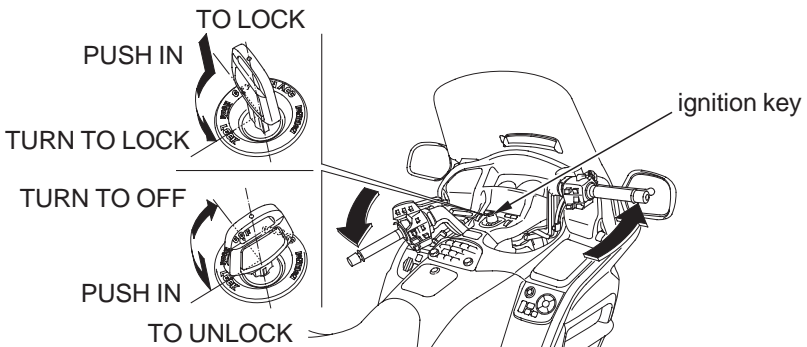

(cont'd)

Parking

- Use the helmet holder(s) to secure your helmet(s) with your motorcycle:
 - Open the travel trunk (page 52).
 - Turn the knob in the trunk to unlock the helmet holders.
 - Hang your helmet(s), using the D-ring on the helmet strap.
 - Push the holder in to lock it.

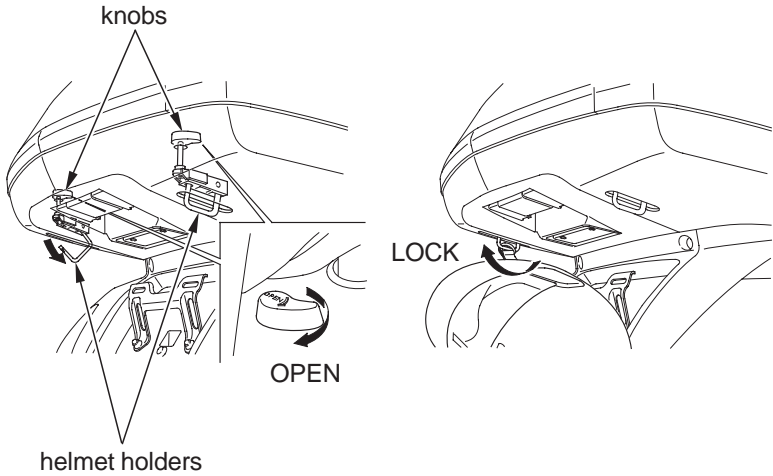

NOTICE

Riding with a helmet attached to the helmet holder can cause damage to the helmet, or damage to the paint or finish of your motorcycle.

Theft-prevention Tips

- Park your motorcycle in a locked garage whenever possible. If a garage isn't available, park in a concealed area or in a well-lit area with enough pedestrian traffic to discourage a thief.
- Always take the ignition key with you.
- Always use the steering lock (page 89), even if you're parking for just a minute or two. A thief can easily push an unlocked motorcycle to a waiting truck.
- In addition to the steering lock, use a good quality anti-theft device made specifically to lock a motorcycle to a secure object.
- If you decide to use an anti-theft device, select one of good quality and be sure to follow the manufacturer's instructions.
- Keep your owner's manual, current registration, and insurance information with your motorcycle. This will make it easier for the authorities to find you if your motorcycle is stolen and recovered.

Riding with a Passenger or Cargo

Your motorcycle is designed to carry you and one passenger. Whenever you add a passenger or cargo, you must be careful not to exceed the total load limits for this vehicle (*Load Limits*, page 50). Make sure your cargo is properly secured (*Loading Guidelines*, page 51).

Also consider adjusting the suspension (page 180) for the extra load.

Be aware that carrying a passenger or heavy cargo can affect acceleration, braking, and handling.

Before riding with a passenger, make sure your passenger is wearing the proper protective apparel (page 44).

Tell your passenger to hold the passenger handgrip, lean with you in the turns, and keep their feet on the passenger footrests at all times, even when the motorcycle is stopped at a traffic light.

Riding with Cruise Control

Cruise Control

The cruise control system allows you to maintain a steady speed between 30–100 mph (48–161 km/h). When cruise control is on, your speed will still vary slightly, particularly going up and down hills.

Cruise control is intended for use only on straight, uncongested highways. Do not use cruise control on city streets, winding roads, during bad weather, or at any other time when you need total control of the throttle.

WARNING

Improper use of the cruise control can lead to a crash.

Use the cruise control only when traveling on open highways in good weather.

Riding with Cruise Control

RIGHT HANDLEBAR

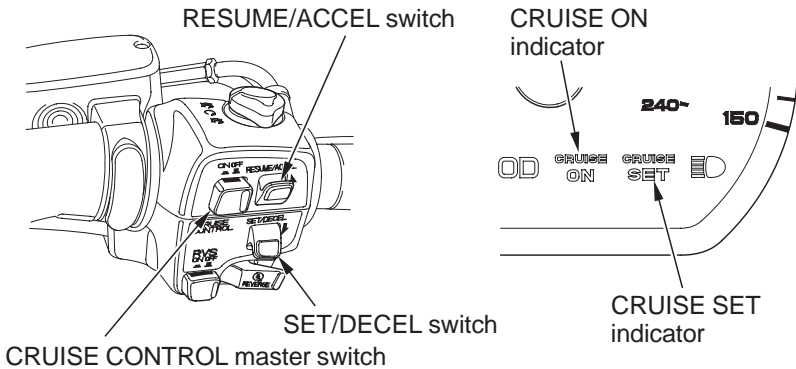

To Set Cruise Control

1. Make sure you are in 4th gear or OD (5th gear), and that your speed is between 30 and 100 mph (48 and 161 km/h). Any speed above 100 mph (161 km/h) will be memorized as 100 mph (161 km/h).
2. Push the CRUISE CONTROL master switch. (The CRUISE ON indicator will come on.)
3. Accelerate to the desired speed.
4. Push the SET/DECEL switch. (The CRUISE SET indicator will come on.)

To Change the Set Speed

To Fine Tune the Set Speed

- To increase the set speed — tap the RESUME/ACCEL switch.
 - To decrease the set speed — tap the SET/DECEL switch.
- Each quick tap (brief push and release) on either switch will change your speed by approximately 1 mph (1.6 km/h).

To Automatically Change the Set Speed

- To increase the set speed — hold the RESUME/ACCEL switch in. The system will accelerate your motorcycle automatically. When you reach the desired speed, release the switch.
- To decrease speed — hold the SEL/DECEL switch in. The system will automatically slow your motorcycle. When you reach the desired speed, release the switch.

Riding with Cruise Control

To Manually Increase the Set Speed

1. Use the throttle to accelerate until you reach the desired speed.
2. Push and release the SET/DECEL switch.

To Manually Increase Vehicle Speed

1. Use the throttle in the normal manner to accelerate.
2. To return to the set speed, close the throttle and coast without applying the brakes. The cruise system will maintain the speed you previously set.

To Cancel Cruise Control

To Disengage the System

1. Push the CRUISE CONTROL master switch until the CRUISE ON indicator goes off. (The set speed will be erased from memory.)

To Temporarily Disengage the System

1. Pull the brake lever or clutch lever slightly, or step on the brake pedal slightly, or close the throttle. (The set speed will remain in memory.)
2. To resume cruise control:
 - If you are still over 30 mph (48 km/h) — push the RESUME/ACCEL switch.
 - If you are under 30 mph (48 km/h) — use the throttle to increase road speed above 30 mph (48 km/h) and then push the RESUME/ACCEL switch.

Riding in Bad Weather

If you decide to ride your motorcycle in the rain, fog, or other bad-weather conditions, ride carefully. Wet road surfaces reduce traction, especially in turns, and increase stopping distances when you brake.

If the weather turns bad while you are riding, take extra care and do not use cruise control.

When riding in the rain, we recommend you adjust your windscreen height below eye level, if possible, for better visibility (page 63).

Avoid using any kind of water-dispersing product on the windscreen. It will damage the plastic.

Audio Systems

This section gives information about the controls and displays that make up your audio system. All essential controls are within easy reach.

As required by the FCC (USA only):

This device complies with Part 15 of the FCC Rules for Radio Receiver.

Operation is subject to the condition that this device may not cause harmful interference. Any unauthorized changes or modifications to this equipment would void the user's authority to operate this device.

Trade Name: Panasonic

Model No: CR-LH0660A CR-LH0560A CR-LH0862AJ
 CR-LH0561A CR-LH0562A CR-LH0863AJ

Responsible Party: Panasonic Corporation of North America
 One Panasonic Way, Secaucus, NJ 07094

Audio Systems	99
MODE Knob/Button Function	99
VOLUME Knob/Button Function	100
Display Locations	101
Controls Locations	103
Audio Component Locations	105
System Control	106
Switch Output	107
VOLUME Control	108
Tone Control	109
Fader Control	111
Ambience (AMB)	112
Beep Set	113
Auto Volume Control (AVC)	114
Muting	115
AM/FM Radio	116
Radio Antenna	116
Select Band	117
Select Station	118
Preset Stations	119
Auto Select	120

(cont'd)

Audio Systems

XM Radio (USA only)	121
Receiving Satellite Radio Service	121
Operating the XM Radio.....	124
XM Radio Display Messages	124
Select Channel.....	125
Preset Channel.....	126
Weather Information.....	127
Weather Band (WB)	127
Auxiliary Function	129
Auxiliary (AUX) Input	129
Input Jack Setup	130
Intercom (I-COM) System.....	132
System Control.....	132
VOLUME Control	133
Intercom Muting.....	134
Navigation System	135
System Control.....	135
Switch Output.....	135
Navi Volume Control.....	136

MODE Knob/Button Function

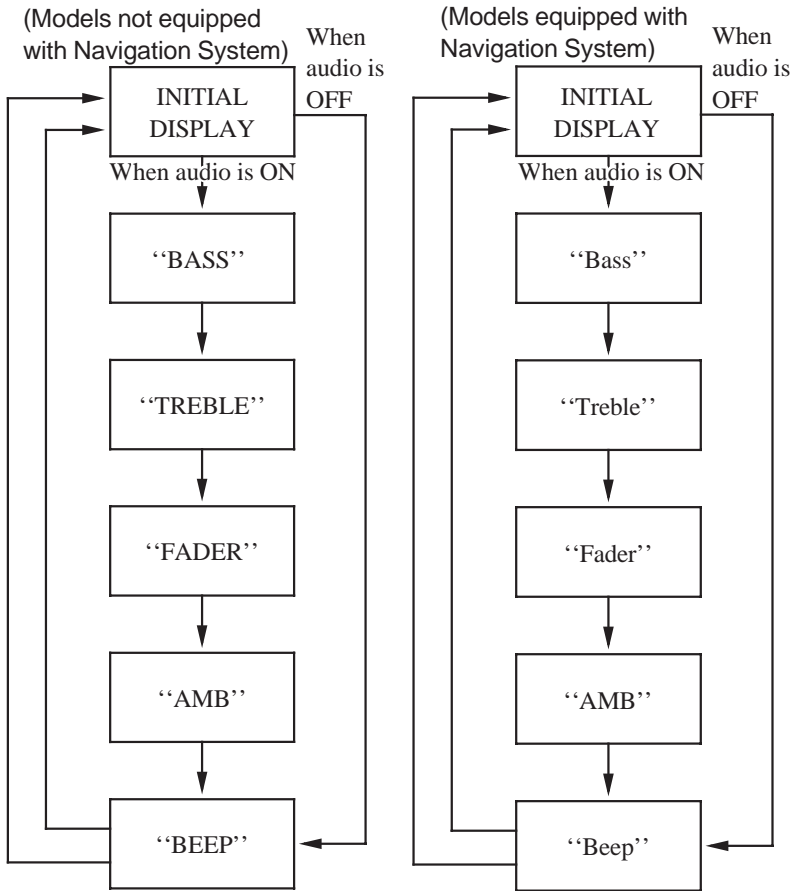

• —————> Push the MODE Knob/Button

Audio Systems

VOLUME Knob/Button Function

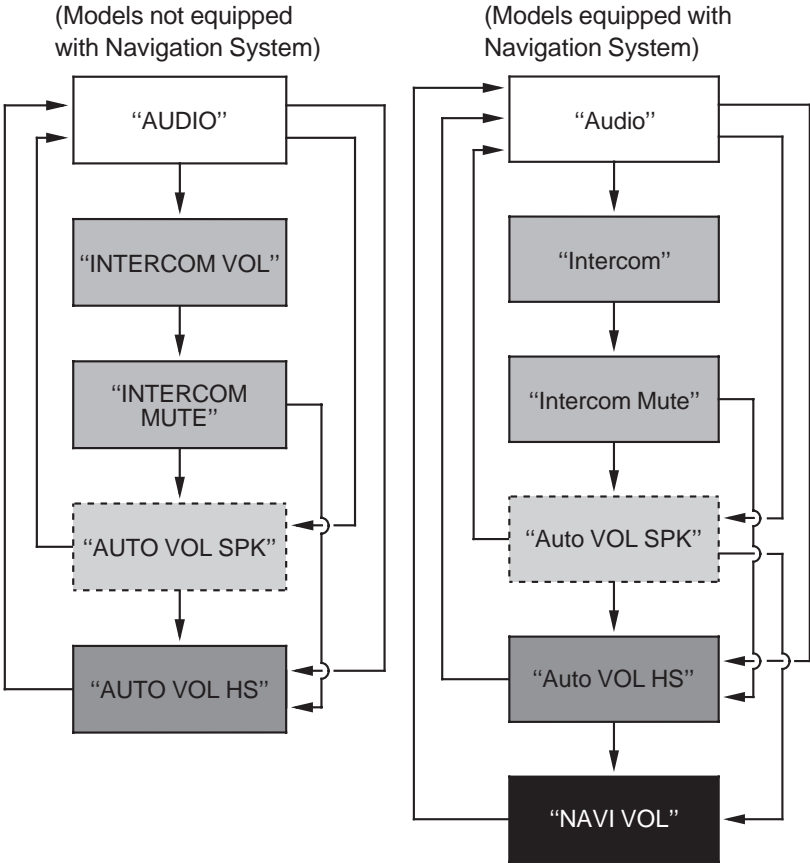

• → Push the VOLUME Knob/Button

• [Grey Box] When INT. COM is ON

• [Dark Grey Box] When the headset is used

• [Dashed Box] When the speaker is used

• [Black Box] Vehicle equipped with Navigation System

Display Locations

(Models not equipped with Navigation System)

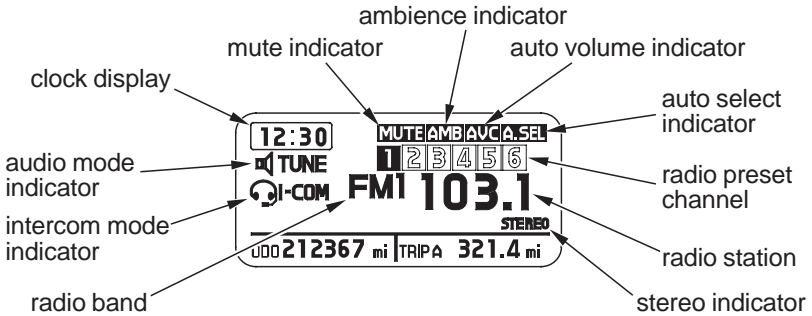

(Models equipped with Navigation System)

For USA

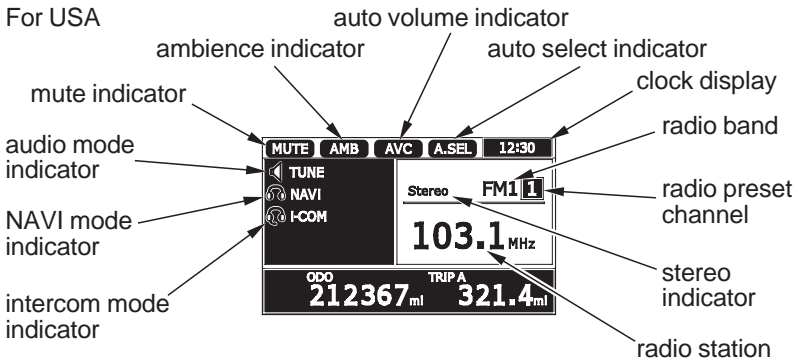

For Canada

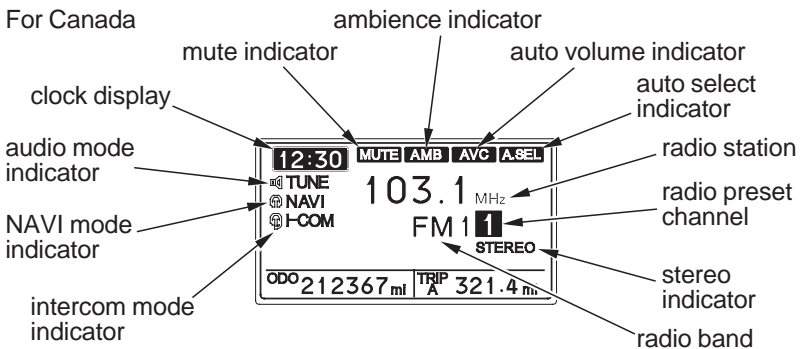

Audio Systems

(Models equipped with Navigation System)

Press the DISP button to toggle between the Multi Information Display (time, audio, odo and trip), a Navi full screen map with the time, and a split screen with the Multi information condensed in a bar below the map.

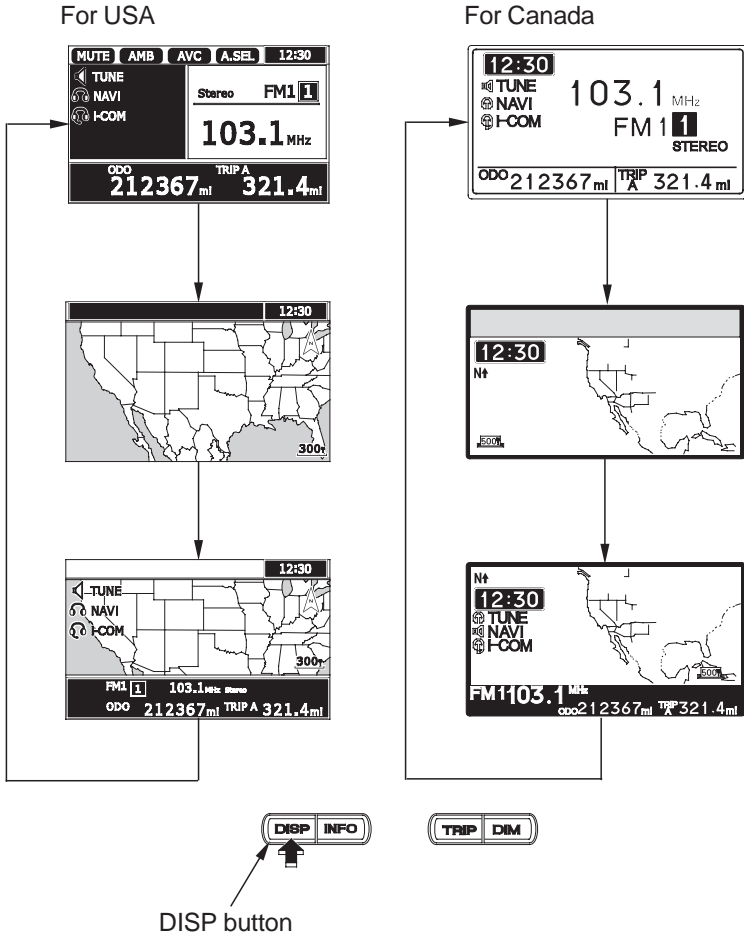

If you are not in the Navigation System when you turn the ignition switch OFF, you will see the audio display when you turn the ignition switch ON again. If you were in the system, you will see the system disclaimer with ENT highlighted.

Controls Locations

(Models not equipped with Navigation System)

LEFT HANDLEBAR

TALK lever
(for accessory CB radio)

CB radio levers
(for accessory CB radio)

VOLUME lever

TUNE/DISC lever

MUTE button

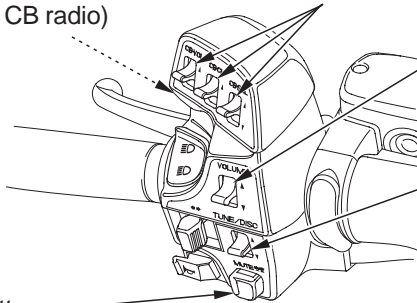

CB button (for accessory CB radio)

AUDIO button

preset buttons

I-COM button

A. SEL button

VOLUME knob/button

FM1 button

FM2 button

AM button

AUX button

MODE knob/button

WB button

CD button (for accessory CD changer)

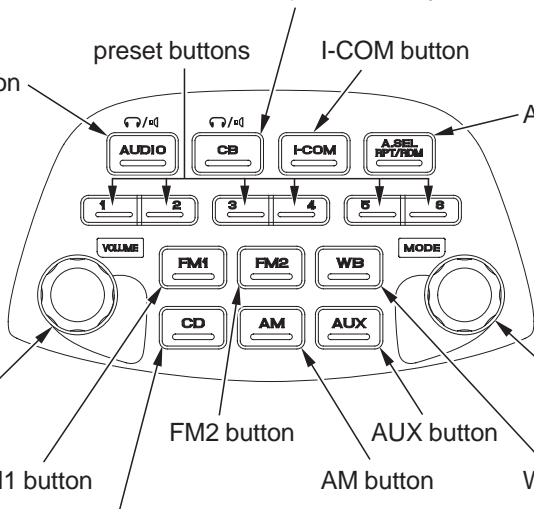

The CB and CD levers and buttons function when the Honda accessory CB radio and/or CD changer are installed. For CB and CD operating instructions, refer to the accessory manuals.

Audio Systems

(Models equipped with Navigation System)

LEFT HANDLEBAR

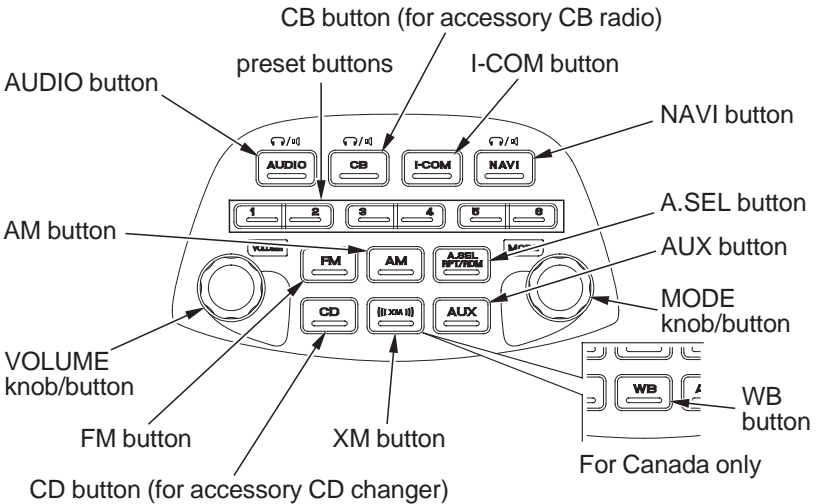
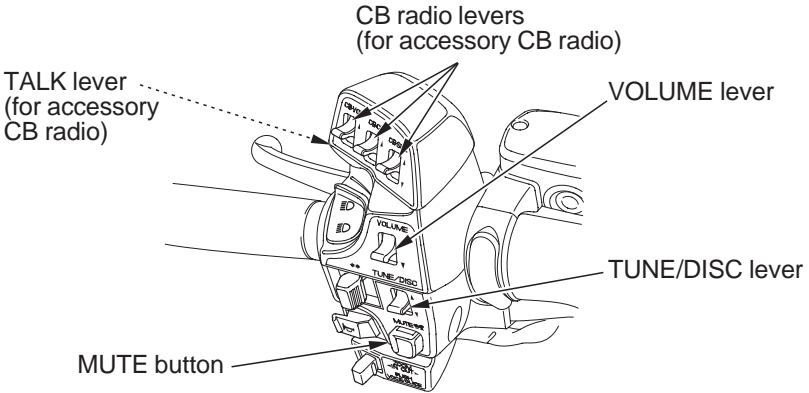

The CB and CD levers and buttons function when the Honda accessory CB radio and/or CD changer are installed. For CB and CD operating instructions, refer to the accessory manuals.

For navigation system operating instructions, refer to the Navigation System Manual.

Audio Systems

Audio Component Locations

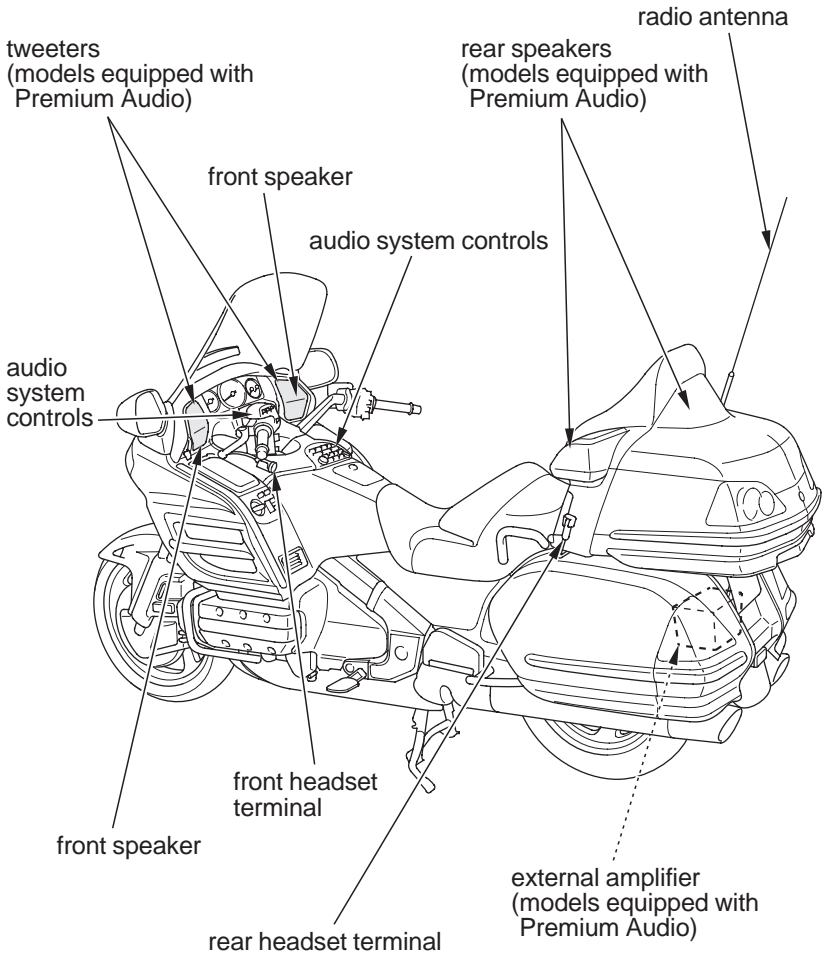

Audio Systems

System Control

To turn the audio system on — push the AUDIO button.

(Models not equipped with Navigation System)

AUDIO button

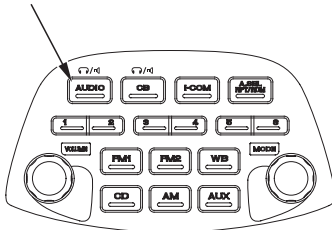

(Models equipped with Navigation System)

AUDIO button

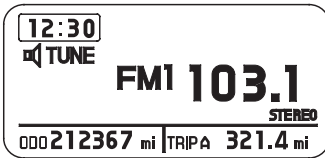
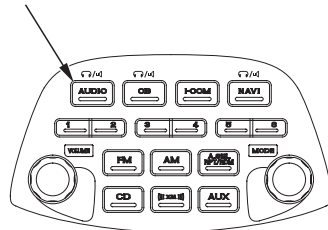

For USA

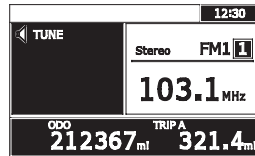

For Canada

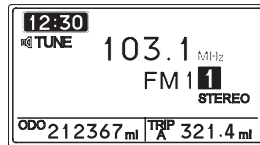

To turn the audio system off — push and hold the AUDIO button.

CB and CD are optional equipment. They are only indicated if installed.

Switch Output

When the audio system is turned on, you can switch its output between Speaker and Headset. (Headset is optional equipment.)

- Pushing the AUDIO button switches the output.

(Models not equipped with Navigation System)

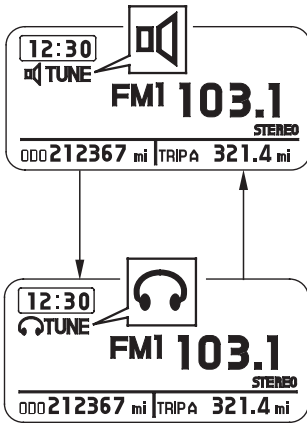

(Models equipped with Navigation System)

For USA

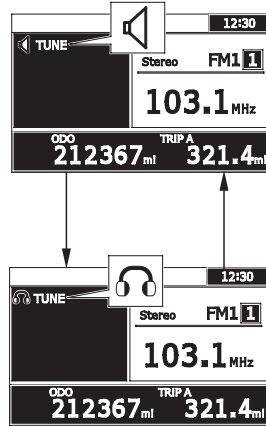

For Canada

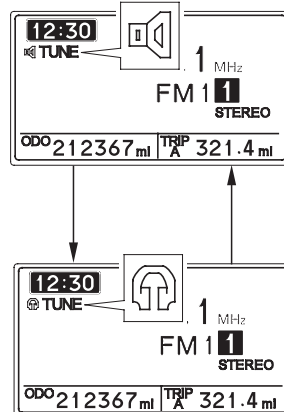

Audio Systems

VOLUME Control

- To increase the volume — push the VOLUME lever up or turn the VOLUME knob/button clockwise.
- To decrease the volume — push the VOLUME lever down or turn the VOLUME knob/button counterclockwise.

To increase or decrease the volume rapidly — push the VOLUME lever up or down and hold it down.

(VOLUME level range: from 0 to 30)

(Models not equipped with Navigation System)

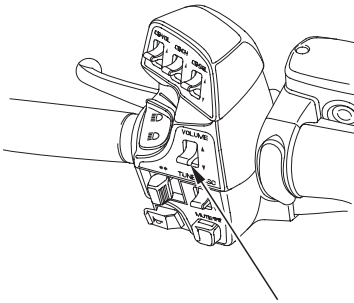

VOLUME lever

(Models equipped with Navigation System)

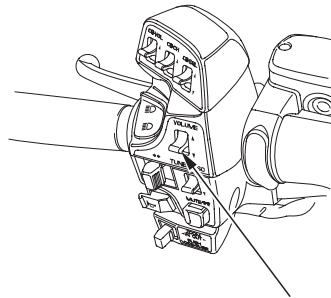

VOLUME lever

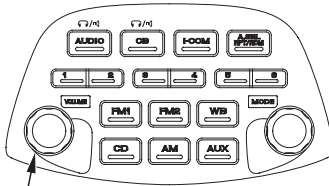

VOLUME knob/button

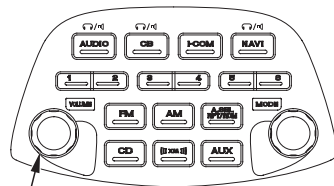

VOLUME knob/button

Tone Control

The tone (Bass — Treble) is automatically adjusted in accordance with the vehicle speed.

Bass:

To select the Bass control, push the MODE knob/button until “BASS” (“Bass”) is displayed (page 99). Then, within 5 seconds, change the bass control.

- To emphasize bass — turn the MODE knob/button clockwise.
- To reduce bass — turn the MODE knob/button counterclockwise (Bass control ranges from 6 down to -6.)

(Models not equipped with Navigation System)

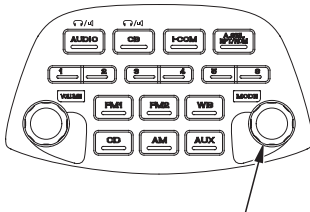

MODE knob/button

(Models equipped with Navigation System)

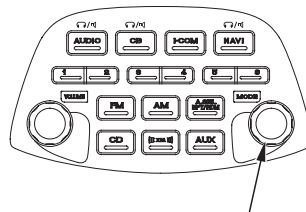

MODE knob/button

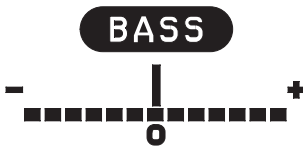

For USA

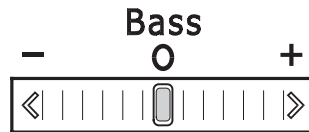

For Canada

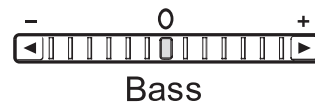

Audio Systems

Treble:

To select the Treble control, push the MODE knob/button until “TREBLE” (“Treble”) is displayed (page 99). Then, within 5 seconds, change the treble control.

- To emphasize treble — turn the MODE knob/button clockwise.
- To reduce treble — turn the MODE knob/button counterclockwise.
(Treble level ranges from 6 down to -6 .)

(Models not equipped with Navigation System)



(Models equipped with Navigation System)

For USA

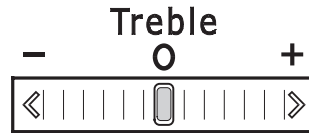

For Canada

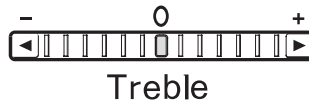

Fader Control

To balance the sound between the front and rear speakers — push the MODE knob/button until “FADER” (“Fader”) is displayed (page 99). Then, within 5 seconds, change the fader control. (The control range: F (front) and R (rear) each have 9 segments.)

(Models not equipped with Navigation System)

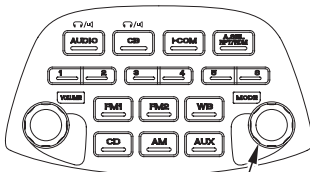

MODE knob/button

(Models equipped with Navigation System)

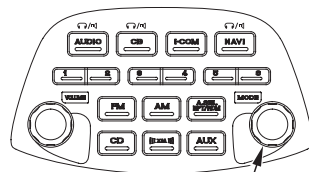

MODE knob/button

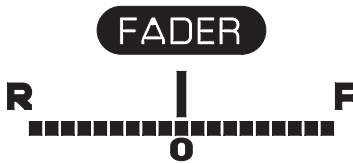

For USA

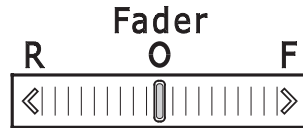

For Canada

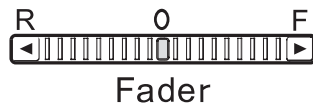

“FADER” (“Fader”) can be shown on the display, but the Fader control does not function properly without the rear speaker. The rear speaker is an optional equipment for the models without the Premium Audio.

Audio Systems

Ambience (AMB)

The “ambience” circuit blends and boosts certain frequencies from both channels, for a “live performance” effect. AMB may be used for stereo programs from the FM radio. However, the ambience circuit may make weak FM stereo signals sound worse.

- To use the circuit — push the MODE knob/button until “AMB” (“Ambiance”) is displayed (page 99). Then, within 5 seconds, change the ambience setting.
- To change the setting — turn the MODE knob/button (There are three settings: HI (High), LO (Low), OFF (Off)).

(Models not equipped with Navigation System)

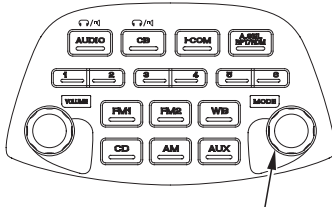

MODE knob/button

(Models equipped with Navigation System)

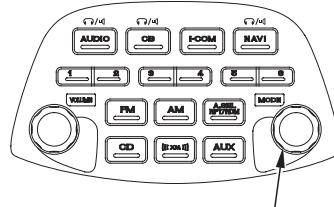

MODE knob/button

AMB

OFF

For USA

Ambiance



For Canada



AMB

Beep Set

- To use the circuit — push the MODE knob/button until “BEEP” (“Beep”) is displayed (page 99). Then, within 5 seconds, change the beep setting.
- To change the setting — turn the MODE knob/button. (ON (On) or OFF (Off))

(Models equipped with Navigation System)

At the same time, the Beep function of the Navigation System is also set.

(Models not equipped with Navigation System)

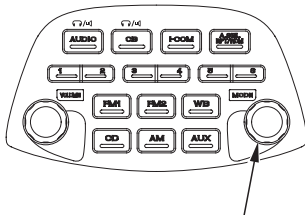

MODE knob/button

(Models equipped with Navigation System)

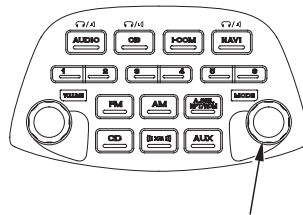

MODE knob/button

BEEP

OFF

For USA

Beep



For Canada

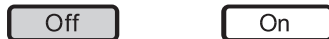

Beep

Audio Systems

Auto Volume Control (AVC)

To automatically increase volume as the speed of the motorcycle increases. Push the VOLUME knob/button until “AUTO VOL SPK” (“Auto Speaker Vol”) is displayed (page 100). To select the volume control of headset, push the VOLUME knob/button until “AUTO VOL HS” (“Auto Headset Vol”) is displayed (page 100). Then, within 5 seconds, change the AVC setting.

AUTO VOL SPK has four settings – HI (High), MID (Mid), LO (Low), and OFF (Off).

AUTO VOL HS has three settings – HI (High), LO (Low), and OFF (Off).

(Models not equipped with Navigation System)

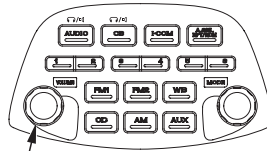

VOLUME knob/button

AUTO VOL SPK
MID

AUTO VOL HS
OFF

(Models equipped with Navigation System)

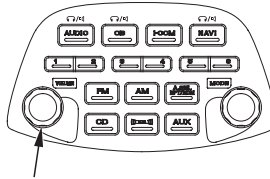

VOLUME knob/button

For USA
Auto Speaker Vol
Off | Low | Mid | High

Auto Headset Vol
Off | Low | High

For Canada
Auto VOL SPK
Off | Low | Mid | High

Auto VOL HS
Off | Low | High

Muting

To instantly lower the radio's volume so you may hear surrounding sounds more clearly — push the MUTE button.

The display will indicate "MUTE".

To restore the original volume — push the MUTE button again to restore the original volume.

LEFT HANDLEBAR

MUTE

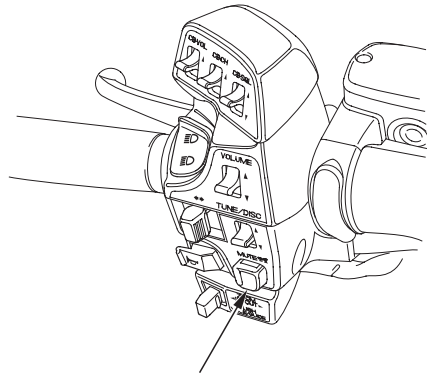

MUTE button

AM/FM Radio

Radio Antenna

To fold the AM/FM radio antenna, pull up on the knurled coupling.

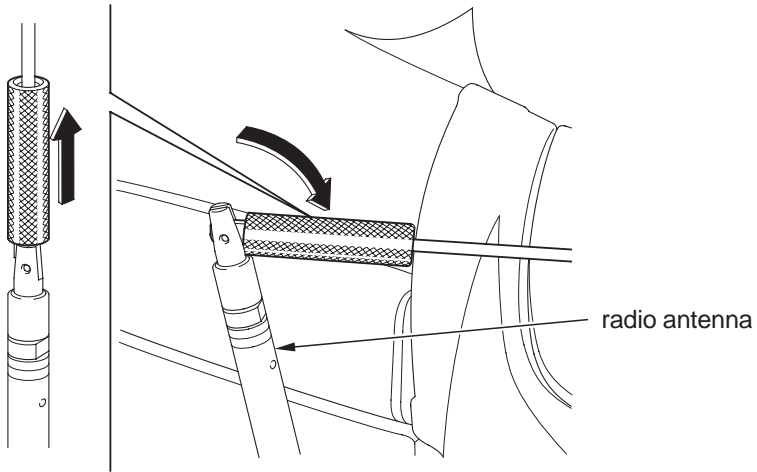

AM/FM Radio

Select Band

(Models not equipped with Navigation System)

To change to AM or FM when you are in the radio mode — push the AM button, FM1 button or FM2 button.

(Models equipped with Navigation System)

Push the FM button to switch to FM1/FM2.

Push the AM button to switch to AM/WB (USA only).

Push the AM button to listen to AM (Canada only).

Reception of a stereo signal is indicated when the STEREO indicator appears in the display. (Stereo reception is available only for FM stereo broadcasts.) As FM stereo reception becomes weaker, special circuits in the radio gradually blend the sound toward mono to maintain some sound quality, even though the STEREO indicator remains ON.

(Models not equipped with Navigation System)

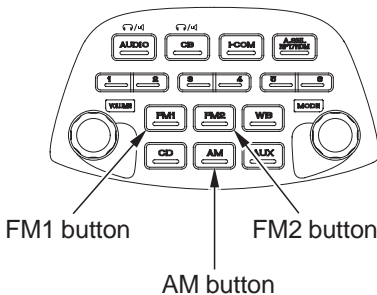

(Models equipped with Navigation System)

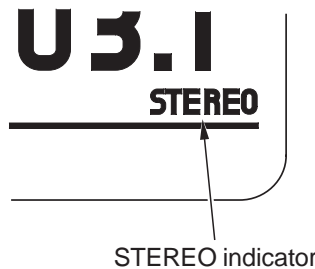
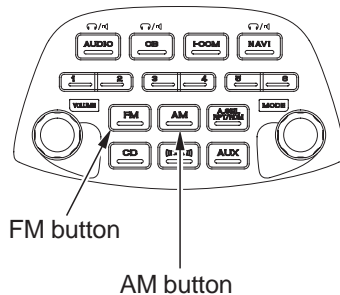

AM/FM Radio

Select Station

To raise the radio frequency — push the TUNE/DISC lever up.

To lower the radio frequency — push the TUNE/DISC lever down.

To move up or down the radio frequencies in sequence, move the lever one click at a time. The AM frequency display moves in 10 kHz steps. The FM frequency display moves in 0.2 kHz steps.

The SEEK function searches the band for a station with a strong signal. To activate it, push the TUNE/DISC lever up or down and release it. The frequency display will begin moving. Depending on which way you push the switch, the system scans upward or downward from the current frequency.

It stops when it finds a station with a strong signal.

When the frequency display reaches either end, it transitions to the other end of the band and continues in the same direction.

To reach a known frequency rapidly — push the TUNE/DISC lever up or down and continue to hold it down until you see the desired frequency.

LEFT HANDLEBAR

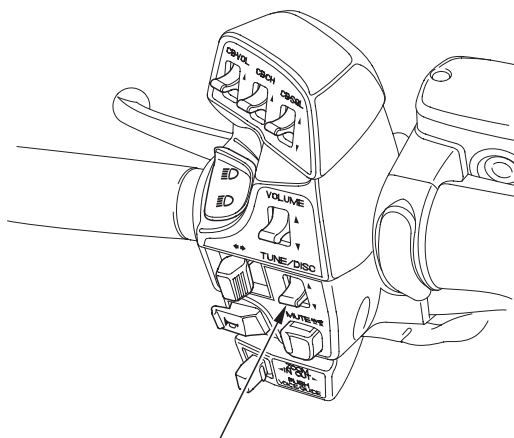

TUNE/DISC lever

AM/FM Radio

Preset Stations

You can store the frequencies of your favorite radio stations in the six preset buttons. Each button will store one frequency on the AM band, and two frequencies on the FM band.

(Models not equipped with Navigation System)

(Models equipped with Navigation System)

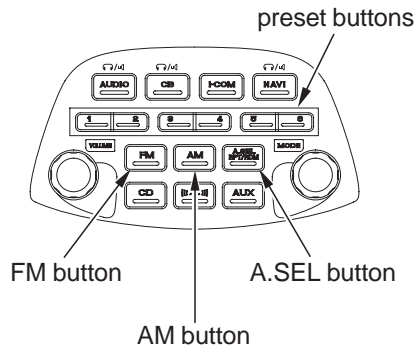
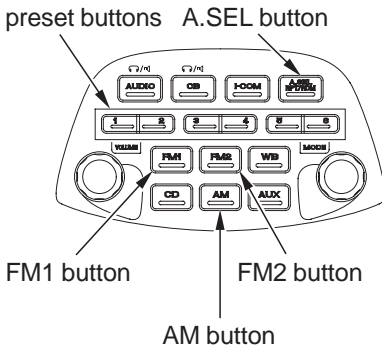

1. Check that A.SEL is not turned on. If it is on, push the A.SEL button to turn it off.
2. Select the desired band, AM or FM. FM1 and FM2 let you store two frequencies with each Preset button.
3. Use the TUNE or SEEK function to tune the radio to a desired station.
4. Pick the Preset button you want for that station. Press the button and hold it.
5. Repeat steps 1 to 3 to store a total of six stations on AM and twelve on FM.

Once a station's frequency is stored, simply press and release the proper Preset button to tune to it. The preset frequencies will be lost if your motorcycle's battery goes low (or dead) or is disconnected, or if the radio fuse is removed.

AM/FM Radio

Auto Select

If you are traveling far from home and can no longer receive the stations you preset, you can use the Auto Select feature to find stations in the local area.

To activate Auto Select, push the A.SEL button. A.SEL will appear in the display, and the system will go into scan mode for several seconds. It automatically scans both bands, looking for stations with strong signals. It stores the frequencies of six AM stations and twelve FM stations in the preset buttons (page 119). You can then use the preset buttons to select those stations.

(Models not equipped with Navigation System)

(Models equipped with Navigation System)

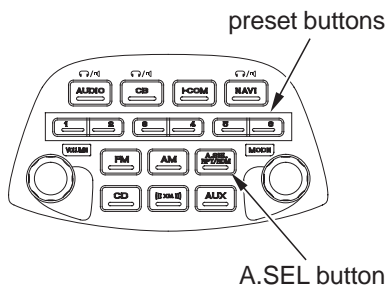
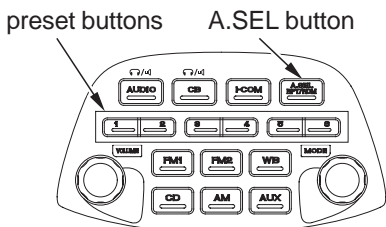

If you are in a remote area, Auto Select may not find six strong AM stations or twelve strong FM stations. If this happens, you will see a “0” displayed when you push any preset button that does not have a station stored.

With Auto Select on, you cannot manually store any frequencies in the preset buttons. If you do not like the stations found by Auto Select, you can use the TUNE and SEEK functions to find other stations.

Auto Select does not erase the frequencies that you preset previously. When you return home, turn off Auto Select by pressing the A.SEL button. The preset buttons will then select the frequencies you originally set.

XM Radio (USA only)

(Models equipped with Navigation System)

Your motorcycle is capable of receiving XM Satellite Radio anywhere in the United States, except Hawaii and Alaska. XM is a registered trade mark of XM Satellite Radio, Inc.

XM Satellite Radio receives signals from two satellites to produce clear, high-quality digital reception. It offers many channels in several categories. Along with a large selection of different types of music, XM Satellite Radio also allows you to view channel and category selections in the audio display.

Receiving Satellite Radio Service

If your XM radio service has expired or you purchased your motorcycle from a previous owner, you can listen to a sampling of the broadcasts available on XM Satellite Radio. With the ignition switch in the ACCESSORY or the ON position, press the XM button. A variety of music types and styles will play.

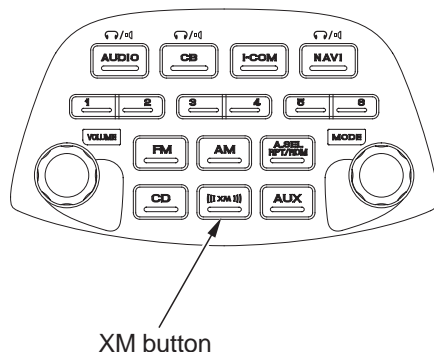

If you decide to purchase XM satellite radio service, contact XM Radio at www.xmradio.com, or at 1-800-967-2346 (1-800-XM-RADIO). You will need to give them your Radio ID number, which may be found on XM Channel 0, and your credit card number.

XM Radio (USA only)

To get your Radio ID number, push the TUNE/DISC lever until CH 0 appears in the display under channel mode (Display channel 0 at only ALL Category search mode) (page 125) or choose Menu screen on the Setup/info menu, highlight XM Info and press ENT.

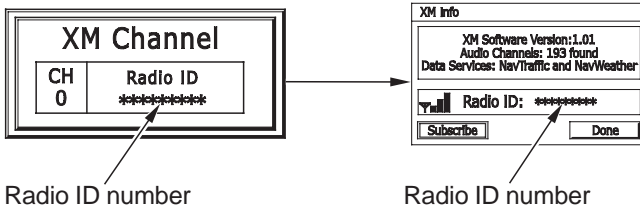

Contact XM Radio at www.xmradio.com, or at 1-800-967-2346 (1-800-XM-RADIO).

After you've registered with XM Radio, keep your audio system in the Satellite Radio mode while you wait for activation. This should take about 30 minutes.

While waiting for activation, make sure your vehicle remains in an open area with good reception. XM Radio will continue to send an activation signal to your motorcycle for at least 3 hours from the activation request. If you miss that window, simply log onto www.xmradio.com refresh with your Radio ID and follow the steps to refresh the signal.

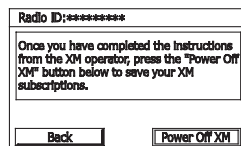
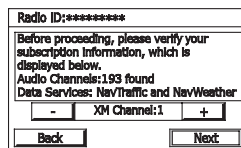
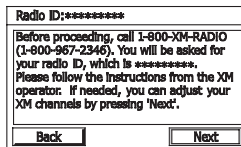

XM Radio (USA only)

The XM satellites are in orbit over the equator; therefore, objects south of the vehicle may cause satellite reception interruptions. To help compensate for this, ground-based repeaters are placed in major metropolitan areas.

Satellite signals are more likely to be blocked by tall buildings and mountains the farther north you travel from the equator. Carrying large items on a travel trunk can also block the signal.

Depending on where you ride, you may experience reception problems. Interference can be caused by any of these conditions:

- Riding on the north side of an east/west mountain road.
- Riding on the north side of a large commercial truck on an east/west road.
- Riding in tunnels.
- Riding on a road beside a vertical wall, steep cliff, or hill to the south of you.
- Riding on the lower level of a multi-tiered road.
- Riding on a single-lane road alongside dense trees taller than 50 ft. (15 m) to the south of you.

There may be other geographic situations, parking conditions, and also installing metallic or metalized accessories near the windscreen could affect XM radio reception.

As required by the FCC:

Changes or modifications not expressly approved by the party responsible for compliance could void the user's authority to operate the equipment.

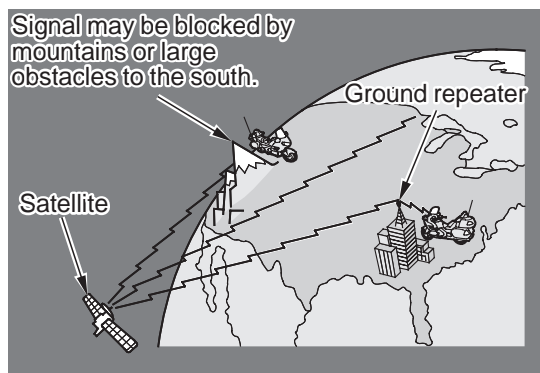

Signal is weaker in these areas.

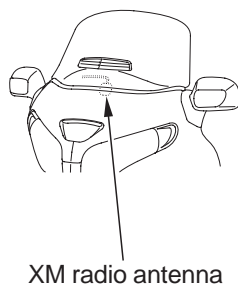

XM Radio (USA only)

Operating the XM Radio

To listen to XM satellite radio, turn the ignition switch to the ON or ACCESSORY position, and push the XM button. The last channel you listened to will show in the display.

Push the XM button to switch to XM1/XM2.

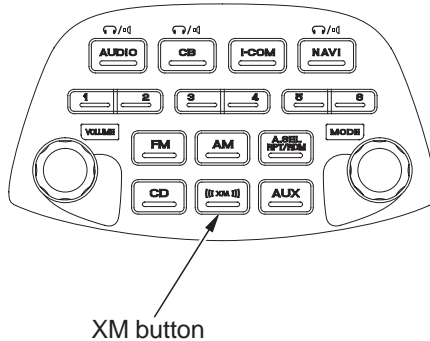

XM Radio Display Messages

Display Message	Status
'LOADING'	XM is loading the audio or program information.
'OFF AIR'	The channel currently selected is no longer broadcasting.
'UPDATING'	The encryption code is being updated. Wait until the encryption code is fully updated. Channels 0 and 1 should still work normally.
'NO XM SIGNAL'	The signal is currently too weak. Move the vehicle to an area away from tall buildings, and with an unobstructed view of the southern horizon.
' _ _ _ _ '	The selected channel number does not exist, or is not part of your subscription, or this channel has no artist or title information at this time.
'CHECK XM ANTENNA'	There is a problem with the XM antenna. Please consult your dealer.

XM Radio (USA only)

Select Channel

To select channel from XM Channel, push the TUNE/DISC lever.

To select channel from XM Category, push and hold the TUNE/DISC lever then select the category while XM Category is displaying.

Push the TUNE/DISC lever up or down and continue to hold it down until you see the desired channel.

In the channel mode, you can select all of the available channels. In the category mode, such as Jazz, Rock, Classical, etc., you can select all of the channels within that category.

You may experience periods when XM radio does not transmit the artist's name and song title information. If this happens, there is nothing wrong with your system.

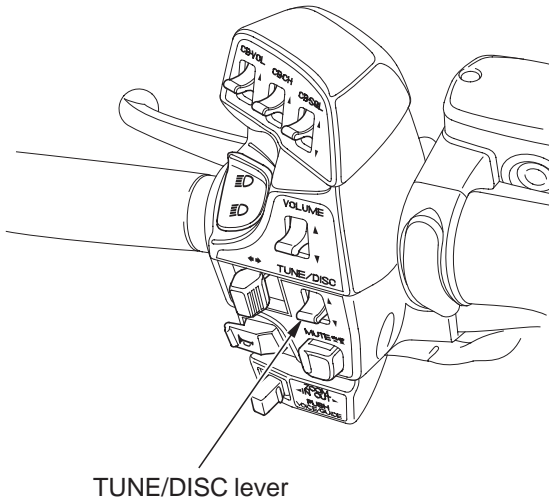

XM Channel

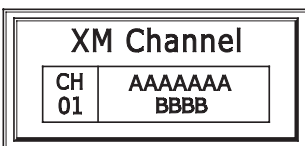

XM Category

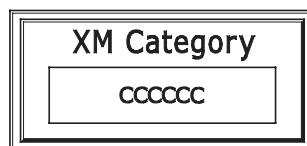

XM Radio (USA only)

Preset Channel

You can store the channels of your favorite up to 12 preset channels using the six preset buttons. Each button stores one channel from the XM1 band and one channel from the XM2 band.

1. Push the XM button to select XM1 or XM2.
2. Select the channel (page 125).
3. Pick the Preset button you want for that channels. Press and hold the preset button until you hear a beep.
4. Repeat steps 2 and 3 to store a total of six channels on each XM1 and XM2.

Once a channel is stored, simply press and release the proper preset button to tune to it. The preset channels will be lost if your motorcycle's battery goes low (or dead) or is disconnected, or if the radio fuse is removed.

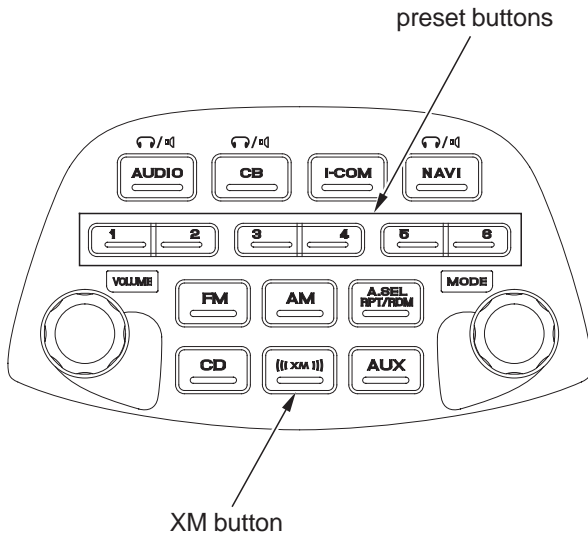

Weather Information

Weather Band (WB)

(Models not equipped with Navigation System)

To listen to the Weather Band — push the WB button.

To cancel the Weather Band — push another band button (AM, FM1 or FM2).

To select channels 1–6 — push the desired preset button.

To select channel 7 — push the TUNE/DISC lever up or down until channel 7 is selected.

(The TUNE/DISC lever may be used to select any of the 7 channels. The lever must be used to select channel 7.)



LEFT HANDLEBAR

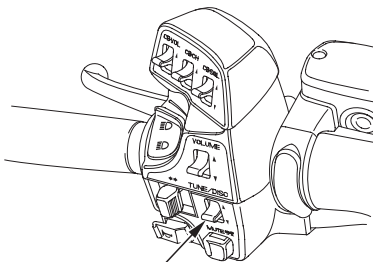

TUNE/DISC lever

preset buttons

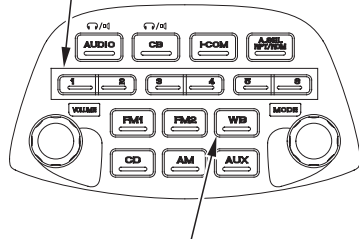

WB button

Weather Information

(Models equipped with Navigation System)

For USA

To listen to the Weather Band — push the AM button to switch AM/WB.

To cancel the Weather Band — push the AM button again or another band button (FM or XM).

For Canada

To listen to the Weather Band — push the WB button.

To cancel the Weather Band — push another band button (AM or FM).

To select channels 1–6 — push the desired preset button.

To select channel 7 — push the TUNE/DISC lever up or down until channel 7 is selected.

(The TUNE/DISC lever may be used to select any of the 7 channels. The lever must be used to select channel 7.)

For USA

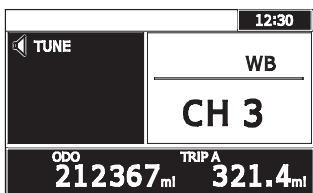

For Canada



LEFT HANDLEBAR

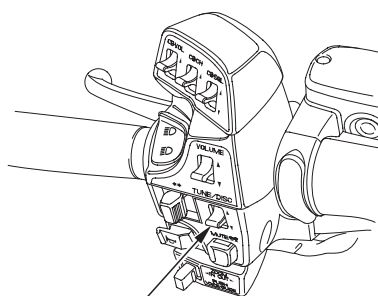

TUNE/DISC lever

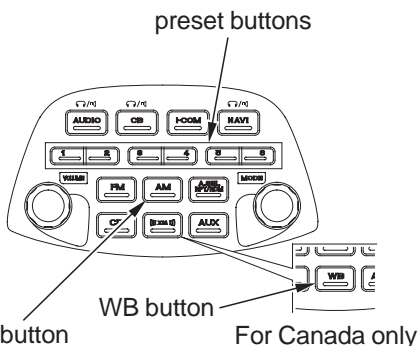

AM button

WB button

For Canada only

Auxiliary Function

Auxiliary (AUX) Input

Use this function to listen to other audio such as a portable CD player:

- To turn the function on — push the AUX button. (AUX appears on the display.)
- To turn the function off — push the AM, FM1, FM2, FM, or WB button.

The following functions operate the same as they do with the AM/FM radio:
Switch output, Tone control, Fader control, AMB, AVC, BEEP, Muting.

(Models not equipped with
Navigation System)

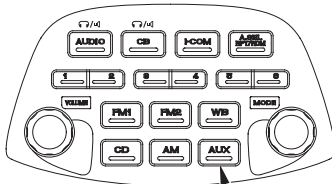

AUX button

(Models equipped with
Navigation System)

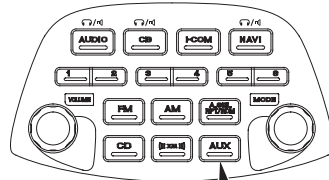

AUX button

AUX

AUX indicator

Auxiliary Function

Input Jack Setup

The auxiliary input jack connector is located under the left fairing pocket. To use it:

1. Attach a cloth to the cover and remove the cover with care using a flat-tip screwdriver.
2. Open the left fairing pocket cover and remove the clips and grommet A.
3. Lift out the fairing pocket.

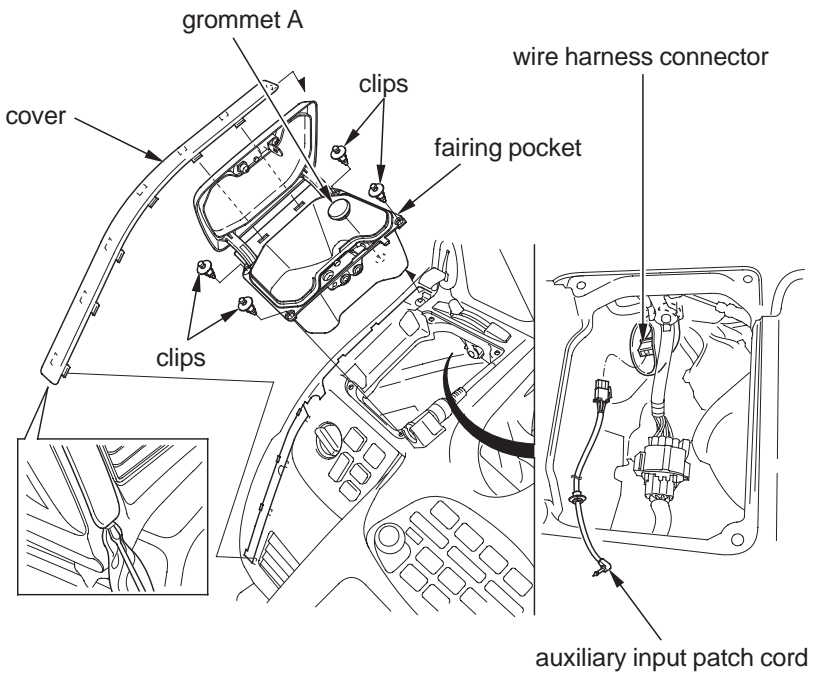

4. Remove the auxiliary input patch cord from the owner's manual pouch.
5. Plug the auxiliary input patch cord into the wire harness connector.

Auxiliary Function

6. Route the auxiliary input patch cord through the hole in the bottom of the fairing pocket.
7. Install the grommet B to left fairing pocket.
Do not pull on the auxiliary cord as the wires could be damaged.

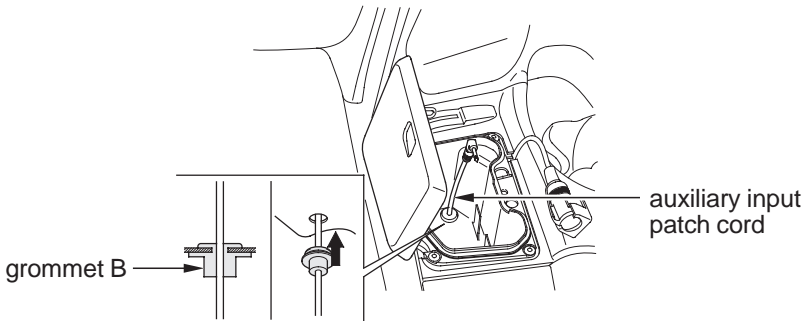

- Some portable audio systems may pick up noise from the ignition.
- Adjust the volume of the portable audio system so that it is about the same level as the GL's radio volume. If the volume of the portable audio system is set too high, the sound coming out from the speakers or headset may be distorted.

Intercom (I-COM) System

System Control

Some local governments prohibit the use of a headset by the operator of a motor vehicle. Always obey applicable laws and regulations.

The intercom system may be used to communicate with your passenger. (If you want to use this system, you must have headsets.)

- To turn the system on — push the I-COM button. (I-COM appears on the display.)
- To turn the system off — push and hold the I-COM button. (I-COM disappears.)

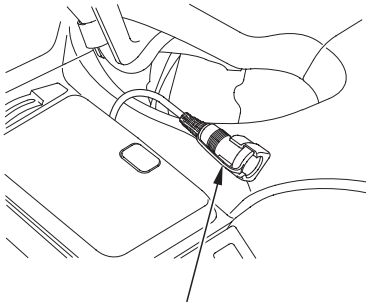

front headset terminal

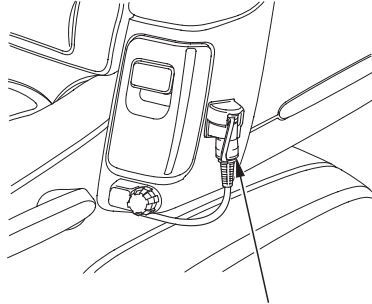

rear headset terminal

(Models not equipped with Navigation System)

I-COM button

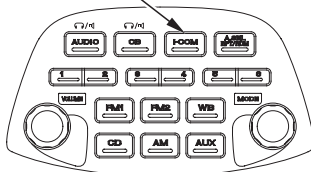

(Models equipped with Navigation System)

I-COM button

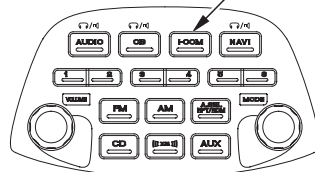

I-COM mode indicator



Intercom (I-COM) System

VOLUME Control

To select the Volume control, push the MODE knob/button until “INTERCOM VOL” (“Intercom”) is displayed (page 100). Then, within 5 seconds, change the volume control.

- To increase the volume — push the VOLUME lever up or turn the VOLUME knob/button clockwise.
- To decrease the volume — push the VOLUME lever down or turn the VOLUME knob/button counterclockwise.

To increase or decrease the volume rapidly — push the VOLUME lever up or down and hold it down.

(VOLUME level range : from 0 to 20)

(Models not equipped with Navigation System)

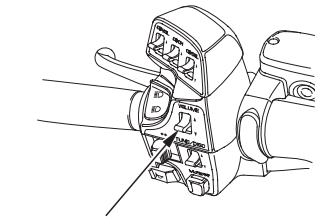

VOLUME lever

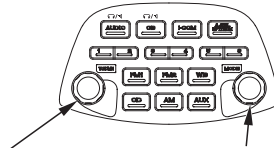

VOLUME knob/button MODE knob/button



(Models equipped with Navigation System)

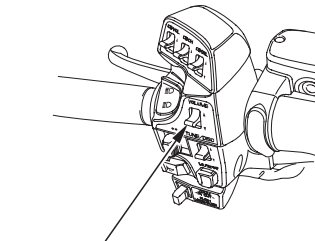

VOLUME lever

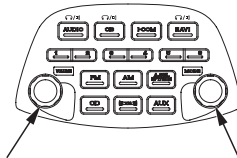

VOLUME knob/button MODE knob/button

For USA Volume 8



For Canada



Intercom (I-COM) System

Intercom Muting

The intercom mute system automatically lowers (does not silence) the music/program volume when you speak through the intercom.

The sensitivity of the intercom microphone to your voice or ambient sound sets the level at which the intercom system mutes the music/program volume.

To adjust this system — push the VOLUME knob/button until “INTERCOM MUTE” (“Intercom Mute”) is displayed (page 100).

- To increase microphone sensitivity — turn the VOLUME knob/button clockwise.
- To decrease microphone sensitivity — turn the VOLUME knob/button counterclockwise. (Intercom Mute control range: from 0 to 20)

(Models not equipped with Navigation System)

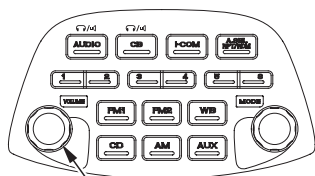

VOLUME knob/button

INTERCOM MUTE

VOL 8

(Models equipped with Navigation System)

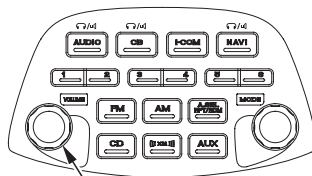

VOLUME knob/button

For USA

Volume 8



Intercom Mute

For Canada

Vol 8



Intercom Mute

Navigation System

System Control

To turn the Navi voice on with the Navigation System turned off — push the NAVI button.

To turn the Navi voice off with the Navigation System turned on — push and hold the NAVI button.

For USA

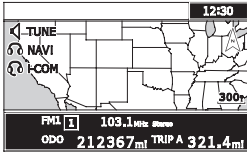

For Canada

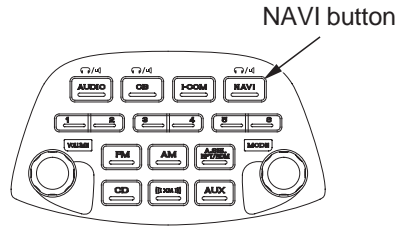

Switch Output

When the navigation voice guidance is turned on, you can switch its output between Speaker and Headset (optional equipment).

- Push the NAVI button switches output.

For USA

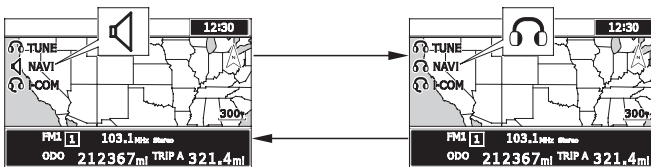

For Canada

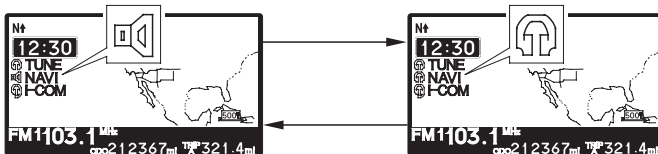

Navigation System

Navi Volume Control

To select the volume control, push the VOLUME knob/button until “NAVI VOL” is displayed (page100). Then, within the 5 seconds, change the navigation volume control.

To make the Navi volume louder than the audio volume — push the VOLUME lever up or turn the VOLUME knob/button clockwise.

To make the Navi volume quieter than the audio volume — push the VOLUME lever down or turn the VOLUME knob/button counterclockwise.

To increase or decrease the volume rapidly — push the VOLUME lever up or down and hold it down.

(NAVI VOLUME level ranges: from 5 down to -5)

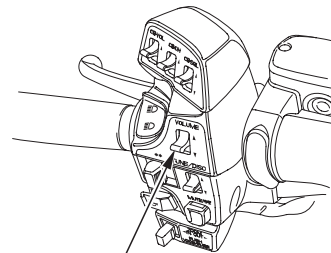

VOLUME lever

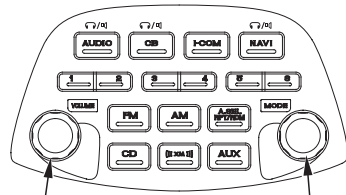

VOLUME knob/button

MODE knob/button

For USA



For Canada

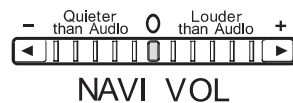

Servicing Your Honda

To help keep your motorcycle in good shape, this section includes a Maintenance Schedule for required service, a list of periodic checks you should perform at least once a month, and step-by-step instructions for specific maintenance tasks. You'll also find important safety precautions, information on fuels and oils, and tips for keeping your Honda looking great.

For information about the exhaust emission and noise emission requirements of the U.S. Environmental Protection Agency (EPA), the California Air Resources Board (CARB), and Environment Canada (EC), see page 251.

For information about replacing fuses, see page 232.

USA only

Maintenance, replacement or repair of the emission control devices and systems may be performed by any motorcycle repair establishment or individual using parts that are “certified” to EPA standards.

Before You Service Your Honda

The Importance of Maintenance.....	140
Maintenance Safety.....	141
Important Safety Precautions.....	142
Periodic Maintenance.....	143
Maintenance Schedule	144
Maintenance Record	148

(cont'd)

Servicing Your Honda

Service Preparations

Maintenance Component Locations	149
Tool Kit	152
Owner's Manual Storage	153
Cover Removal.....	154
Clip Removal.....	159

Service Procedures

Fluids & Filters

Fuel	160
Engine Oil & Filter.....	163
Coolant	170
Crankcase Breather	173
Final Drive Oil.....	174

Engine

Clutch System.....	176
Spark Plugs.....	178

Chassis

Suspension.....	180
Brakes	184
Tires	189
Side Stand.....	196

Electrical

Battery	197
---------------	-----

Appearance Care	201
-----------------------	-----

Servicing Your Honda

The following table summarizes the three types of inspections and servicing recommendations for your motorcycle. Both the pre-ride inspection and the scheduled maintenance at the recommended intervals are necessary to assure safe and dependable performance. The periodic checks provide additional confidence in your motorcycle's performance.

Type of Inspection/ Service	Refer to page:	When Performed	Who Performs
Pre-ride Inspection	47	before every ride	you
Periodic Maintenance	143	monthly*	you
Maintenance Schedule	144	interval on schedule	your Honda dealer**

* more often if you ride frequently or long distances; or anytime you clean your motorcycle

**unless you have the proper tools and service data and are mechanically qualified

The Importance of Maintenance

Keeping your motorcycle well-maintained is absolutely essential to your safety. It's also a good way to protect your investment, get maximum performance, avoid breakdowns, and have more fun. A properly maintained motorcycle will also help to reduce air pollution.

Remember, proper maintenance is the owner's responsibility. Be sure to inspect your motorcycle before each ride, perform the periodic checks, and follow the Maintenance Schedule in this section.

WARNING

Improperly maintaining this motorcycle or failing to correct a problem before you ride can cause a crash in which you can be seriously hurt or killed.

Always follow the inspection and maintenance recommendations and schedules in this owner's manual.

If your motorcycle overturns or is involved in a crash, be sure your Honda dealer inspects all major parts, even if you are able to make some of the repairs yourself.

Maintenance Safety

This section includes instructions on how to perform some important maintenance tasks. If you have basic mechanical skills, you can perform many of these tasks with the tools provided with your motorcycle.

Other tasks that are more difficult and require special tools are best performed by professionals. Wheel removal should normally be handled only by a Honda technician or other qualified mechanic. Instructions are included in this manual only to assist in emergency service.

Some of the most important safety precautions follow. However, we cannot warn you of every conceivable hazard that can arise in performing maintenance. Only you can decide whether or not you should perform a given task.

WARNING

Failure to properly follow maintenance instructions and precautions can cause you to be seriously hurt or killed.

Always follow the procedures and precautions in this owner's manual.

Maintenance Safety

Important Safety Precautions

- Make sure the engine is off before you begin any maintenance or repairs. This will help eliminate several potential hazards:
 - Carbon monoxide poisoning from engine exhaust.** Be sure there is adequate ventilation whenever you operate the engine.
 - Burns from hot motorcycle parts.** Let the engine and exhaust system cool before touching.
 - Injury from moving parts.** Do not run the engine unless instructed to do so.
- Read the instructions before you begin, and make sure you have the tools and skills required.
- To help prevent the motorcycle from falling over, park it on a firm, level surface, using the center stand.
- To reduce the possibility of a fire or explosion, be careful when working around gasoline. Use only non-flammable solvent, not gasoline, to clean parts. Keep cigarettes, sparks, and flames away from all fuel-related parts.

Remember that your Honda dealer knows your motorcycle best and is fully equipped to maintain and repair it. To ensure the best quality and reliability, use only new Honda Genuine Parts or their equivalents for repair and replacement. If you have the tools and skills required for additional maintenance jobs, you can purchase an official Honda Service Manual (page 258).

Periodic Maintenance

In addition to the regularly scheduled maintenance (page 144) and daily pre-ride inspection (page 47), consider performing the periodic checks on the following page at least once a month, even if you haven't ridden your motorcycle, or as often as once a week if you ride frequently or for long distances. It's a good idea to perform this maintenance any time you clean your motorcycle.

Check the odometer reading and perform any scheduled maintenance checks that are needed (page 144). Remember, more frequent checks may be needed for riding in severe conditions.

Tires & Wheels	Check the air pressure with a gauge and add air if needed (page 190). Examine the tread for wear (page 191). Look closely for nails, embedded objects, cuts, and other types of damage (page 191). Rotate the rear wheel so you can inspect the entire surface. Check the condition of the wheels.
Fluids	Check the levels of the engine oil (page 166), coolant (page 171), brake fluid (page 185), clutch fluid (page 177), and final drive oil (page 174). Add the correct fluid as necessary, and investigate the cause of any low fluid level.
Lights	Make sure the headlight, brakelight, taillight, and turn signals are working properly.
Fuses	Make sure you have a full supply of spare fuses.
Nuts & Bolts	Check the major fasteners and tighten as needed.

Maintenance Schedule

The required Maintenance Schedule that follows specifies how often you should have your motorcycle serviced, and what things need attention. It is essential to have your motorcycle serviced as scheduled to maintain safe, dependable performance and proper emission control.

The service intervals in this Maintenance Schedule are based on average riding conditions. Some items will need more frequent service if you ride in unusually wet or dusty areas or at full throttle. Consult your Honda dealer for recommendations applicable to your individual needs and use.

Some items in the Maintenance Schedule can be performed with basic mechanical skills and hand tools. Procedures for these items are provided in this manual. Other items involve more extensive procedures and may require special training, tools, and equipment. We recommend that you have your Honda dealer perform these tasks unless you have advanced mechanical skills and the required tools and equipment. Procedures for such items in this schedule are provided in an official Honda Service Manual available for purchase (page 258).

Maintenance Schedule

If you do not feel capable of performing a given task or need assistance, remember that your Honda dealer knows your motorcycle best and is fully equipped to maintain and repair it. If you decide to do your own maintenance, use only Honda Genuine Parts or their equivalents for repair or replacement to ensure the best quality and reliability.

Perform the pre-ride inspection (page 47) and owner maintenance (page 146) at each scheduled maintenance period.

The following items require some mechanical knowledge. Certain items (particularly those marked * and **) may require more technical information and tools. Consult your Honda dealer.

* Should be serviced by your Honda dealer, unless you have the proper tools and service data and are mechanically qualified. Refer to the official Honda Service Manual (page 258).

** In the interest of safety, we recommend these items be serviced only by your Honda dealer.

Summary of Maintenance Schedule Notes & Procedures:

NOTES:

1. At higher odometer readings, repeat at the frequency interval established here.
2. Service more frequently if the motorcycle is ridden in unusually wet or dusty areas.
3. Service more frequently if the motorcycle is ridden often at full throttle or in the rain.
4. Service more frequently if noisy.
5. Replace every 2 years, or at indicated odometer interval, whichever comes first. Replacement requires mechanical skill.
6. Replace at 4,000 mi (6,400 km) or 6 months, then every 8,000 mi (12,800 km) or 12 months.

Maintenance Procedures:

I: inspect and clean, adjust, lubricate,
or replace, if necessary

C: clean

A: adjust

L: lubricate

R: replace

Maintenance Schedule

		FREQUENCY	ODOMETER READING (Note 1)							Refer to page
			× 1,000 mi	4	8	12	16	20	24	
ITEM		NOTE	× 1,000 km	6.4	12.8	19.2	25.6	32.0	38.4	
EMISSIONS-RELATED ITEMS	* FUEL LINE				I		I		I	—
	* THROTTLE OPERATION				I		I		I	—
	* AIR CLEANER	2				R			R	—
	CRANKCASE BREATHER	3		C	C	C	C	C	C	173
	SPARK PLUGS			EVERY 16,000 mi (25,600 km) R						178
	* VALVE CLEARANCE	4		EVERY 32,000 mi (51,200 km) I						—
	ENGINE OIL	6		R		R		R		163
	ENGINE OIL FILTER			R		R		R		167
	RADIATOR COOLANT	5			I		I		R	170
	* COOLING SYSTEM				I		I		I	—
	* SECONDARY AIR SUPPLY SYSTEM				I		I		I	—
	* EVAPORATIVE EMISSION CONTROL SYSTEM					I			I	—

* Should be serviced by your Honda dealer, unless you have the proper tools and service data and are mechanically qualified. Refer to the official Honda Service Manual (page 258).

Maintenance Schedule

		FREQUENCY		ODOMETER READING (Note 1)							Refer to page
				× 1,000 mi	4	8	12	16	20	24	
ITEM		NOTE	× 1,000 km	6.4	12.8	19.2	25.6	32.0	38.4		
NON-EMISSIONS-RELATED ITEMS									R	174	
		5				R			R	185	
										187	
										188	
	*									—	
	*									—	
										176	
		5				R			R	177	
	*									—	
										196	
	*									—	
	*									—	
	**									—	
**									—		

- * Should be serviced by your Honda dealer, unless you have the proper tools and service data and are mechanically qualified. Refer to the official Honda Service Manual (page 258).
- ** In the interest of safety, we recommend these items be serviced only by your Honda dealer.

Maintenance Record

Keeping an accurate maintenance record will help ensure that your motorcycle is properly maintained. Retain detailed receipts to verify the maintenance was performed. If the motorcycle is sold, these receipts should be transferred with the motorcycle to the new owner. Make sure whoever performs the maintenance completes this record. All scheduled maintenance is considered a normal owner operating cost and will be charged for by your dealer. Use the space under Notes to record anything you want to remind yourself about or mention to your dealer.

Miles (km)	Odometer	Date	Performed By:	Notes
4,000 (6,400)				
8,000 (12,000)				
12,000 (19,200)				
16,000 (25,600)				
20,000 (32,000)				
24,000 (38,400)				
28,000 (44,800)				
32,000 (51,200)				
36,000 (57,600)				
40,000 (64,000)				
44,000 (70,400)				
48,000 (76,800)				
52,000 (83,200)				

Maintenance Component Locations

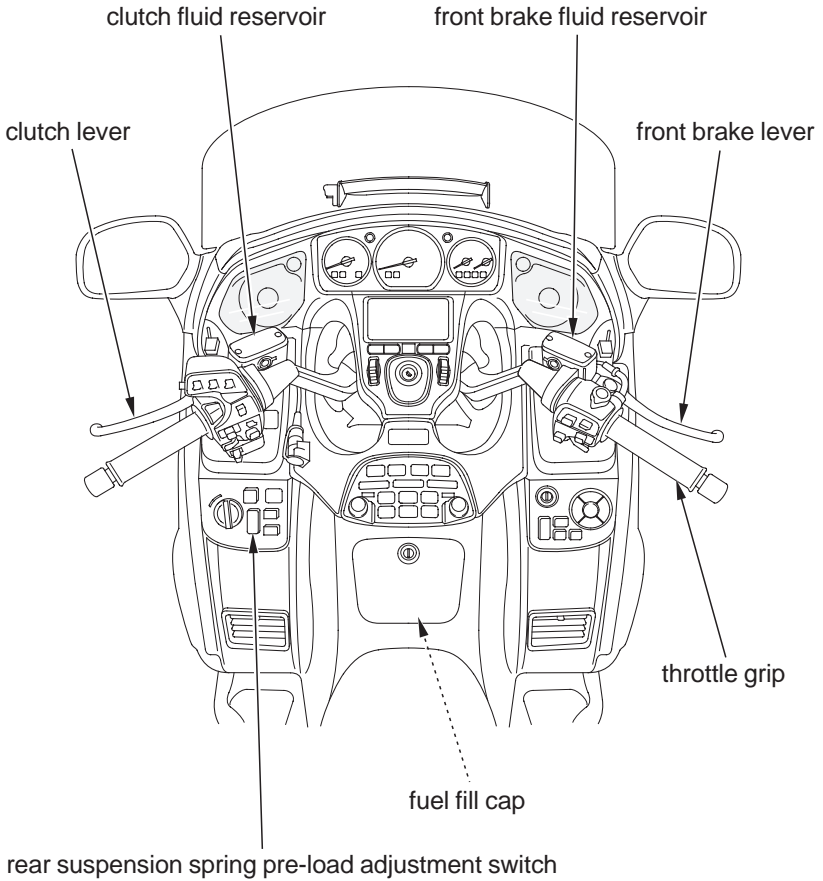

Maintenance Component Locations

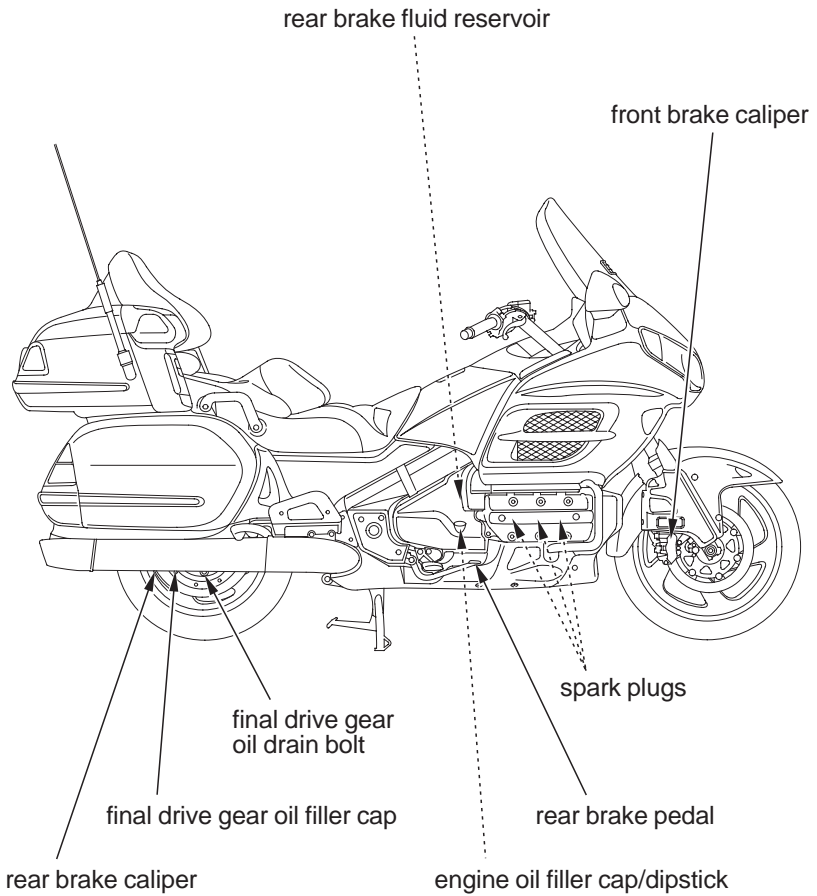

Maintenance Component Locations

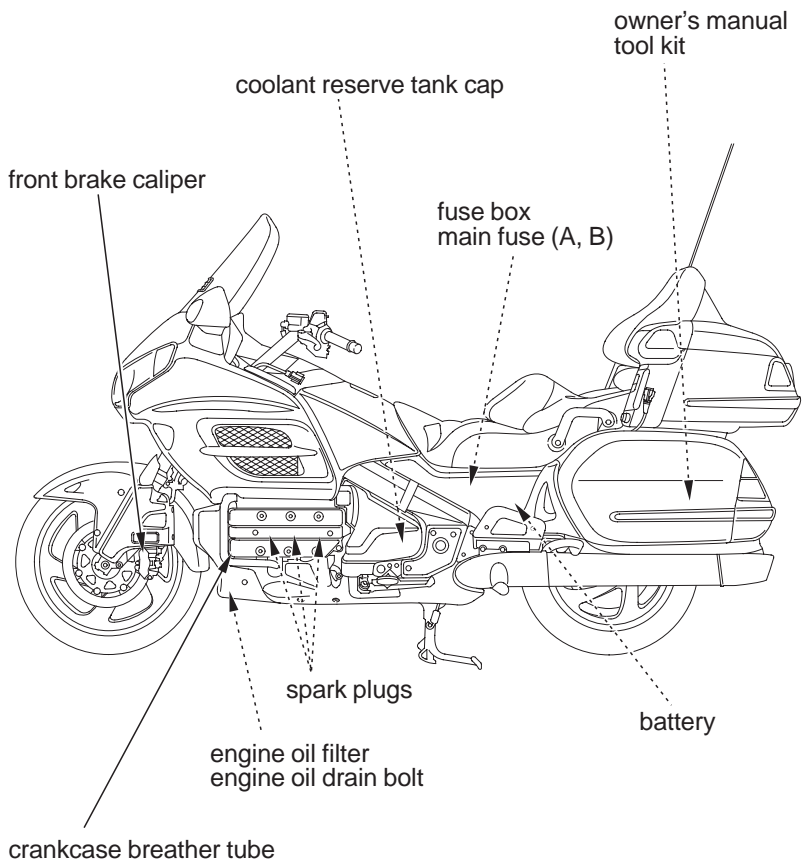

Tool Kit

The tool kit is located in the left saddlebag (page 52).

An optional, larger tool kit may be available. Check with your Honda dealer's parts department.

LEFT SIDE

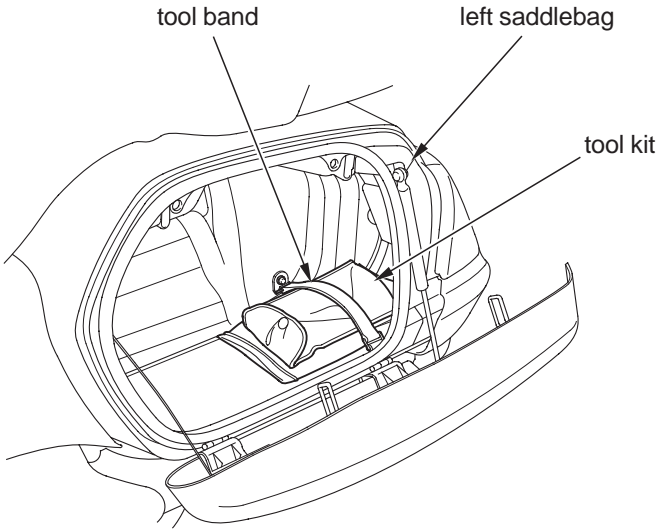

Owner's Manual Storage

Your motorcycle provides storage for the owner's manual so you'll have it with you for easy reference. Store your owner's manual (and other documents) in the plastic storage bag in the left saddlebag (page 52).

For models equipped with Navigation System:

Store your Navigation System Manual with your owner's manual.

For models equipped with Airbag:

Store your Owner's Manual Airbag Supplement and Navigation System Manual with your owner's manual.

Be careful not to flood this area when washing your motorcycle.

LEFT SIDE

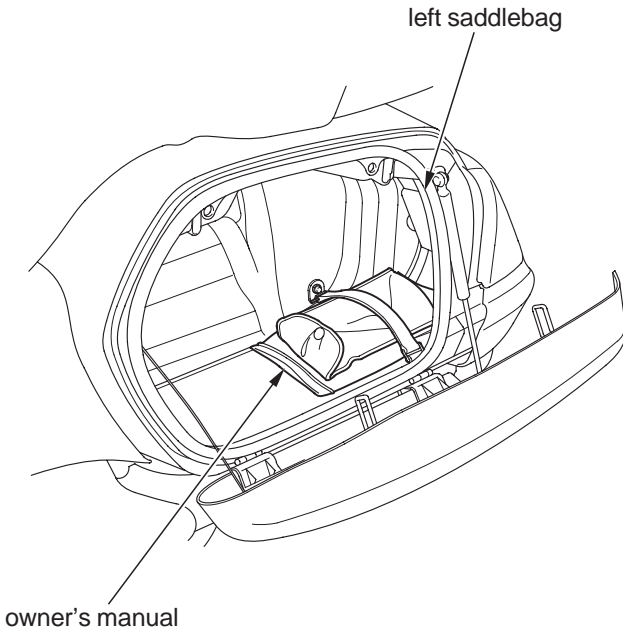

Cover Removal

Refer to *Safety Precautions* on page 142.

Left side shown; right side similar

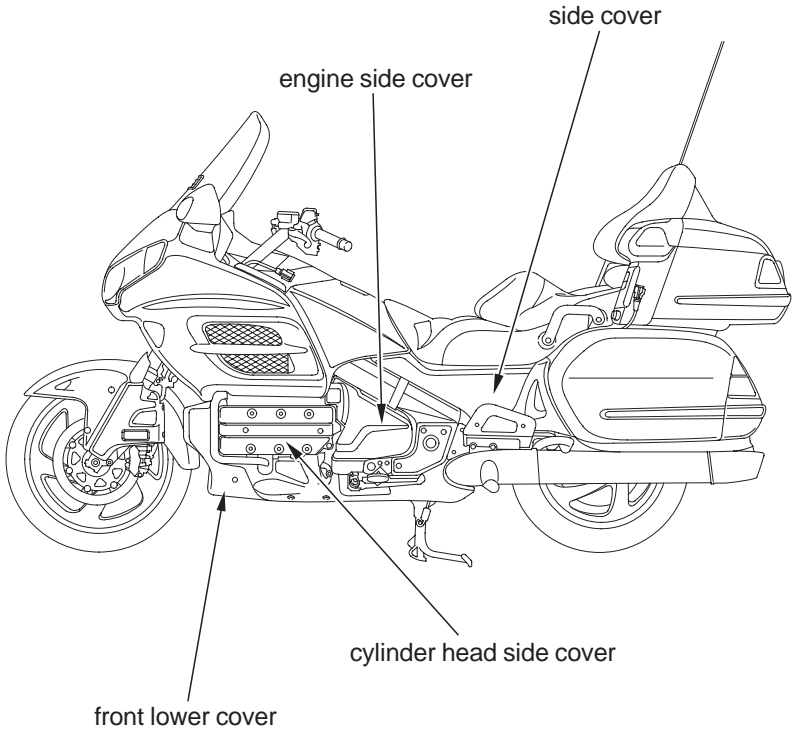

Cover Removal

Side Cover Removal

Refer to *Safety Precautions* on page 142.

The left side cover must be removed for battery and fuse maintenance.

NOTICE

Failure to use extreme care removing or installing the side covers may damage the side cover hooks.

Removal

1. Carefully pull the side cover out until the prongs are clear of the frame grommets.
2. Remove the side cover.

Installation

1. Insert the top edge of the side cover under the seat.
2. Position the side cover so the prongs on the inside of the cover are lined up above their securing grommets.
3. Push the cover in place.

LEFT SIDE

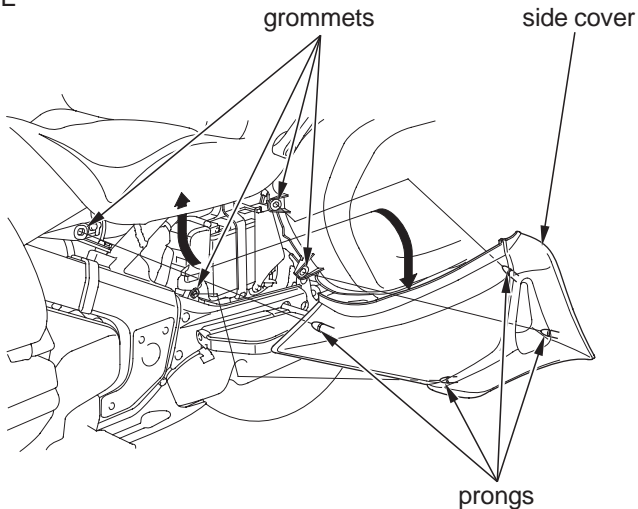

Cover Removal

Engine Side Cover Removal

Refer to *Safety Precautions* on page 142.

The left engine side cover must be removed for coolant maintenance.
The right engine side cover must be removed for engine oil and rear brake fluid maintenance.

NOTICE

Failure to use extreme care removing or installing the side covers may damage the side cover hooks.

Removal

1. Carefully pull the rear of the engine side cover out until the prongs are clear of their securing grommets.
2. Carefully slide the engine side cover to the rear until the hook is clear of the tab in the hole of the engine side cover.

Installation

- Installation can be done in the reverse order of removal.

LEFT SIDE

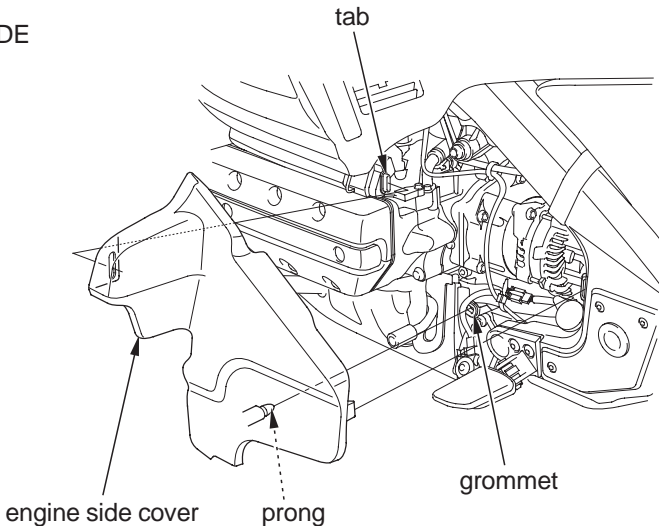

Cylinder Head Side Cover Removal

Refer to *Safety Precautions* on page 142.

Both cylinder head side covers must be removed for spark plug maintenance. The left cylinder head side cover must be removed for crankcase breather maintenance.

Removal

1. Remove the rubber plugs.
2. Remove the bolts.

Installation

- Installation can be done in the reverse order of removal.

LEFT SIDE

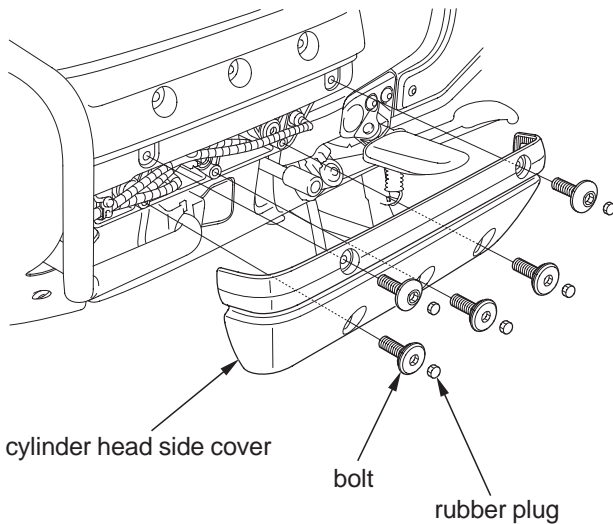

Cover Removal

Front Lower Cover Removal

Refer to *Safety Precautions* on page 142.

The front lower cover must be removed for engine oil maintenance.

Removal

1. Remove the clips.
2. Remove the bolts.

Installation

- Installation can be done in the reverse order of removal.

FRONT

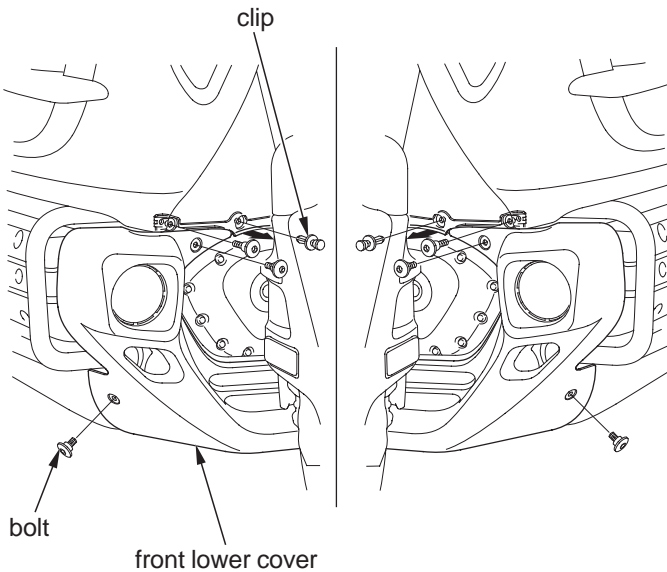

Clip Removal

Removal

1. Press down on the center pin to release the lock.
2. Pull the clip out of the hole.

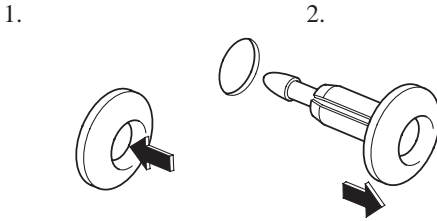

Installation

1. Push the bottom of the pin.
2. Insert the clip into the hole.
3. Lightly press down on the center pin to lock the clip.

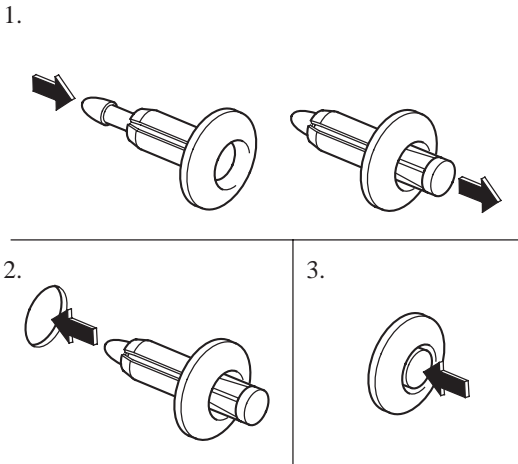

Fuel

Refer to *Safety Precautions* on page 142.

Fuel Recommendation

type	unleaded
pump octane number	86 (or higher)

Use only unleaded fuel in your Honda. Use of leaded fuel will damage the catalytic converter(s). If you ride your Honda in a country where leaded fuel might be available, use precautions to use only unleaded fuel.

Your engine is designed to use any unleaded gasoline that has a pump octane number of 86 or higher. Gasoline pumps at service stations normally display the pump octane number. For information on the use of oxygenated fuels, see page 256 .

Use of lower octane gasoline can cause persistent “pinging” or “spark knock” (a loud rapping noise) which, if severe, can lead to engine damage. Light pinging experienced while operating under a heavy load, such as climbing a hill, is no cause for concern.

If pinging or spark knock occurs at a steady engine speed under normal load, change brands of gasoline. If pinging or spark knock persists, consult your Honda dealer.

Never use stale or contaminated gasoline or an oil/gasoline mixture. Avoid getting dirt, dust, or water in the fuel tank.

Fuel Capacity

Fuel tank capacity, including reserve:
6.6 US gal (25 l)

The tank should be refilled as soon as possible when the fuel gauge needle enters the red band.

Refueling Procedure

Refer to *Safety Precautions* on page 142.

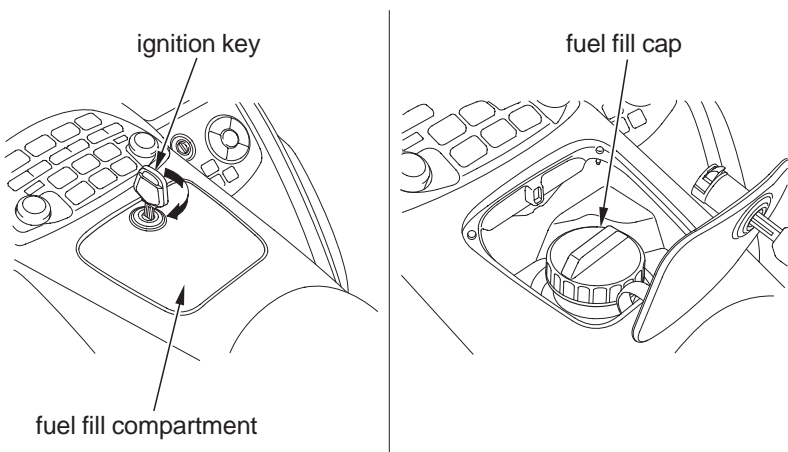

1. Insert the ignition key in the fuel fill compartment and turn it clockwise.
2. Open the fuel fill compartment.
3. Turn the fuel fill cap counterclockwise and remove it.

(cont'd)

Fuel

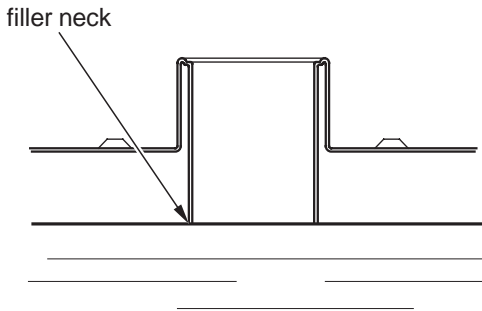

4. Add fuel until the level reaches the bottom of the filler neck.
Avoid overfilling the tank. There should be no fuel in the filler neck.

⚠ WARNING

Gasoline is highly flammable and explosive. You can be burned or seriously injured when handling fuel.

- Stop the engine and keep heat, sparks and flame away.
- Handle fuel only outdoors.
- Wipe up spills immediately.

5. After refueling, be sure to tighten the fuel fill cap firmly by turning it clockwise until it clicks.
6. Close the fuel fill compartment.
7. Remove the key from the fuel fill compartment.

Engine Oil & Filter

Engine oil quality is a major factor that affects both the performance and the service life of the engine.

Using the proper oil (page 164) and filter, and regularly checking, adding, and changing oil will help extend your engine's life. Even the best oil wears out. Changing oil helps get rid of dirt and deposits in the engine. Operating the engine with old or dirty oil can damage your engine. Running the engine with insufficient oil can cause serious damage to the engine and transmission.

Change the engine oil as specified in the maintenance schedule on page 146.

When running in very dusty conditions, oil changes should be performed more frequently than specified in the maintenance schedule.

Engine Oil & Filter

Oil Recommendation

API classification	SG or higher except oils labeled as energy conserving on the circular API service label
viscosity (weight)	SAE 10W-30
JASO T 903 standard	MA
suggested oil*	Pro Honda GN4 4-stroke oil (USA & Canada), or Honda 4-stroke oil (Canada only), or an equivalent motorcycle oil.

* Suggested oils are equal in performance to SJ oils that are not labeled as energy conserving on the circular API service label.

- Your motorcycle does not need oil additives. Use the recommended oil.
- Do not use oils with graphite or molybdenum additives. They may adversely affect clutch operation.
- Do not use API SH or higher oils displaying a circular API “energy conserving” service label on the container. They may affect lubrication and clutch performance.



NOT RECOMMENDED

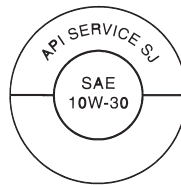

OK

- Do not use non-detergent, vegetable, or castor based racing oils.

Engine Oil & Filter

Other viscosities shown in the following chart may be used when the average temperature in your riding area is within the indicated range.

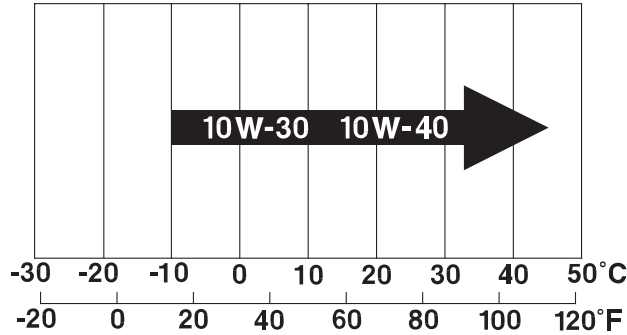

JASO T 903 standard

The JASO T 903 standard is an index for engine oils for 4-stroke motorcycle engines.

There are two classes: MA and MB.

Oil conforming to the standard is labeled on the oil container. For example, the following label shows the MA classification.

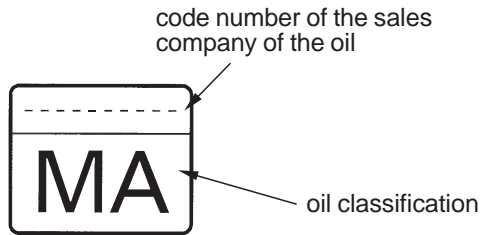

PRODUCT MEETING JASO T 903
COMPANY GUARANTEEING THIS MA PERFORMANCE:

Engine Oil & Filter

Checking & Adding Oil

Refer to *Safety Precautions* on page 142.

RIGHT SIDE

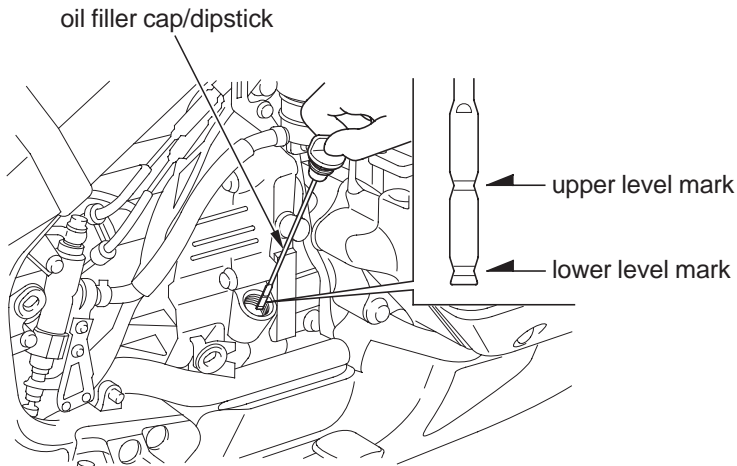

1. Park your motorcycle on its center stand on a firm, level surface.
2. Remove the right engine side cover (page 156).
3. Start the engine and let it idle for 3–5 minutes. Make sure the low oil pressure indicator goes off. If the indicator remains on, stop the engine immediately.
4. Stop the engine and wait 2–3 minutes.
5. Remove the oil filler cap/dipstick and wipe it clean.
6. Insert the oil filler cap/dipstick until it seats, but don't screw it in.
7. Remove the oil filler cap/dipstick and check the oil level.
 - If the oil is at or near the upper level mark — you do not have to add oil.
 - If the oil is below or near the lower level mark — add the recommended oil until it reaches the upper level mark. (Do not overfill.)
8. Reinstall the oil filler cap/dipstick.
9. Reinstall the right engine side cover.
10. Check for oil leaks.

Changing Engine Oil & Filter

Refer to *Safety Precautions* on page 142.

Your motorcycle's oil filter has very specific performance requirements. Use a new Honda Genuine oil filter or a filter of equal quality specified for your model.

NOTICE

Using the wrong oil filter may result in leaks or engine damage.

This procedure requires mechanical skill and professional tools such as a torque wrench and oil filter wrench, as well as a means for disposing of the drained fluid (page 201). If you do not have the skills or the tools, see your Honda dealer.

Drain the Engine Oil:

1. Park your motorcycle on its center stand on a firm, level surface.
2. If the engine is cold, start it and let it idle for 3–5 minutes. Turn the engine off. Wait 2–3 minutes for the oil to settle.
3. Remove the front lower cover (page 158).
4. Place a drain pan under the engine oil drain bolt.
5. To drain the oil, remove the oil filler cap/dipstick, engine oil drain bolt, and sealing washer.

FRONT, UNDER ENGINE

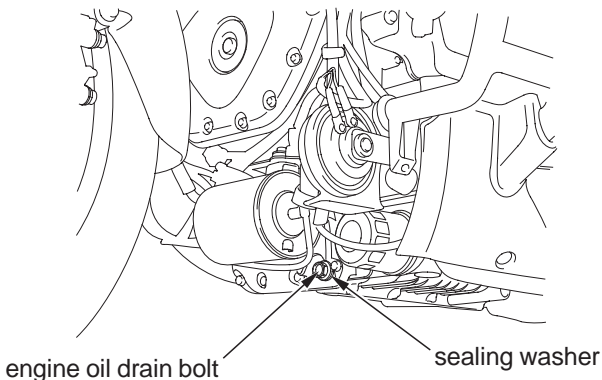

(cont'd)

Engine Oil & Filter

Install a New Oil Filter:

6. Remove the oil filter with a filter wrench and let the remaining oil drain out.
Discard the oil filter in an approved manner (page 211).
7. Pour the drained oil into a suitable container and dispose of it in an approved manner (page 211).

NOTICE

Improper disposal of drained fluids is harmful to the environment.

8. Apply a thin coat of engine oil to the rubber seal of a new oil filter.

LEFT FRONT, UNDER ENGINE

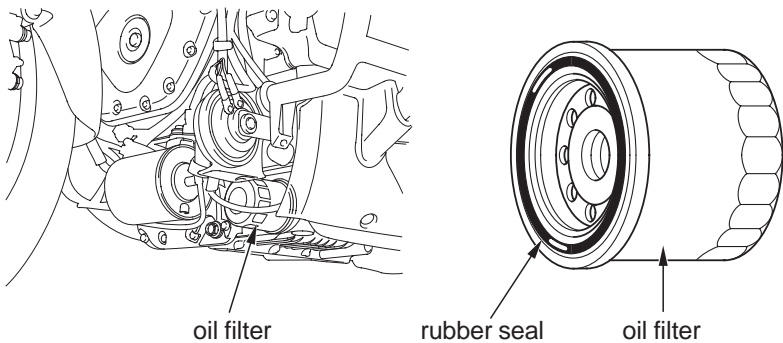

9. Install the new oil filter and tighten it by hand.
10. Using an oil filter wrench attachment and a torque wrench, tighten the new oil filter to the specified torque:
19 lbf·ft (26 N·m , 2.7 kgf·m)
11. Check the condition of the sealing washer on the engine oil drain bolt.
Replace the washer every other time the oil is changed.
Install the engine oil drain bolt and tighten it to the specified torque:
25 lbf·ft (34 N·m , 3.5 kgf·m)

Engine Oil & Filter

Add Engine Oil:

12. Fill the crankcase with the recommended oil (page 164), approximately:
3.9 US qt (3.7 ℓ)
13. Install the oil filler cap/dipstick securely.
14. Start the engine and let it idle for 3–5 minutes.
15. Stop the engine and wait 2–3 minutes.
16. Check that the oil level is at upper level mark on the dipstick (page 166).
17. Check that there are no oil leaks.

If a torque wrench is not used for installation, see your Honda dealer as soon as possible to verify proper assembly.

Coolant

Your motorcycle's liquid cooling system dissipates engine heat through the coolant jacket that surrounds the cylinder and cylinder head.

Maintaining the coolant will allow the cooling system to work properly and prevent freezing, overheating, and corrosion.

Coolant Recommendation

Use Pro Honda HP coolant or an equivalent high quality ethylene glycol antifreeze containing corrosion protection inhibitors specifically recommended for use in aluminum engines. Check the antifreeze container label.

Use only distilled water as a part of the coolant solution. Water that is high in mineral content or salt may be harmful to the aluminum engine.

NOTICE

Using coolant with silicate inhibitors may cause premature wear of water pump seals or blockage of radiator passages. Using tap water may cause engine damage.

The factory provides a 50/50 solution of antifreeze and water in this motorcycle. This coolant solution is recommended for most operating temperatures and provides good corrosion protection.

Decreasing the concentration of antifreeze to less than 40% will not provide proper corrosion protection.

Increasing the concentration of antifreeze is not recommended because it decreases cooling system performance. Higher concentrations of antifreeze (up to 60%) should only be used to provide additional protection against freezing. Check the cooling system frequently during freezing weather.

Checking & Adding Coolant

Refer to *Safety Precautions* on page 142.

LEFT SIDE

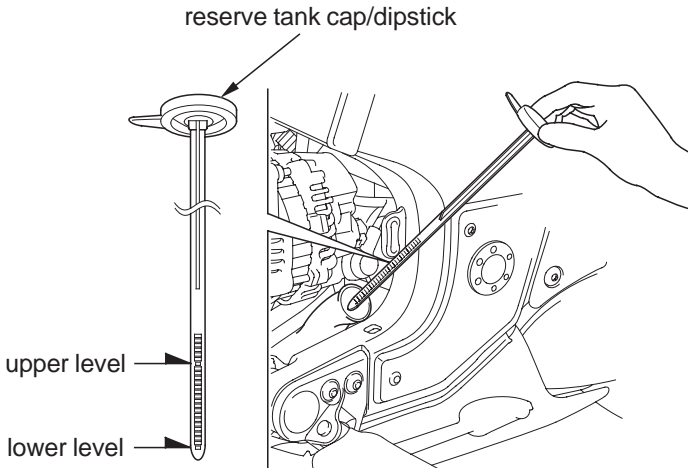

1. Remove the left engine side cover (page 156).
2. With the engine at normal operating temperature, remove the reserve tank cap/dipstick and check the coolant level.
If the reserve tank is empty, or if coolant loss is excessive, check for leaks and see your Honda dealer for repair.
3. Add coolant to the reserve tank as required to bring the coolant level to the upper level mark.
Always add coolant to the reserve tank. Do not attempt to add coolant by removing the radiator cap.
4. Reinstall the left engine side cover.

Coolant

Coolant Replacement

Refer to *Safety Precautions* on page 142.

Coolant should be replaced by your Honda dealer, unless you have the proper tools and service data and are mechanically qualified. Refer to the official Honda Service Manual (page 258).

WARNING

Removing the radiator cap while the engine is hot can cause the coolant to spray out, seriously scalding you.

Always let the engine and radiator cool down before removing the radiator cap.

To properly dispose of drained coolant, refer to *You & the Environment*, page 211.

NOTICE

Improper disposal of drained fluids is harmful to the environment.

Crankcase Breather

Refer to *Safety Precautions* on page 142.

Service the crankcase breather more frequently if your motorcycle is ridden in the rain or often at full throttle. Service the breather if you can see deposits in the transparent section of the drain tube.

Draining

LEFT SIDE

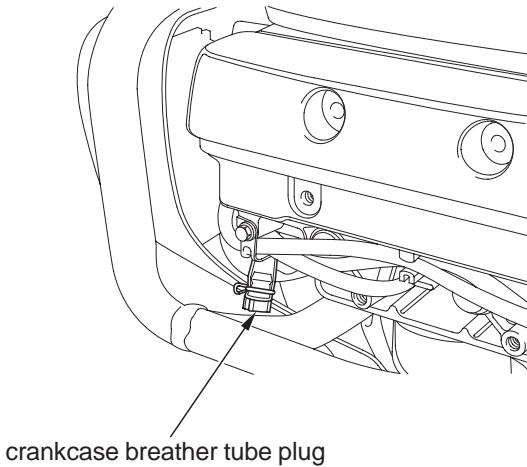

1. Place a drain pan under the crankcase breather tube plug.
2. Remove the left cylinder head side cover (page 157).
3. Remove the plug to drain the deposits in the tube.
4. Reinstall the crankcase breather tube plug.
5. Reinstall the left cylinder head side cover.

Final Drive Oil

Oil Recommendation

type	hypoid gear oil
viscosity (weight)	SAE 80

Checking & Adding Oil

Refer to *Safety Precautions* on page 142.

RIGHT REAR

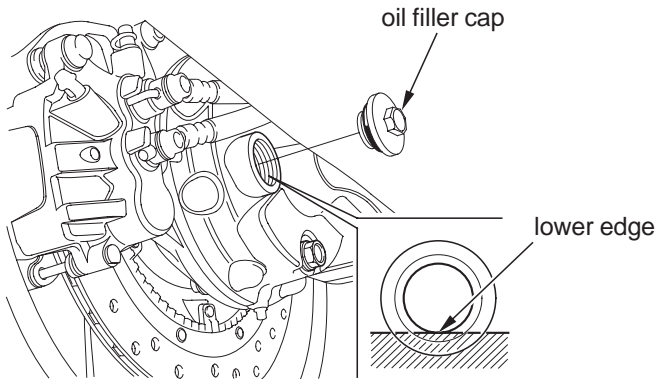

1. Place the motorcycle on its center stand on a firm, level surface.
2. Remove the oil filler cap.
3. Check the oil level. It should be flush with the lower edge of the oil filler hole.
4. If the level is low, check for oil leaks. Add the recommended oil through the oil filler hole until it reaches the lower edge of the opening.
5. Install the oil filler cap.

Changing Oil

Refer to *Safety Precautions* on page 142.

RIGHT REAR

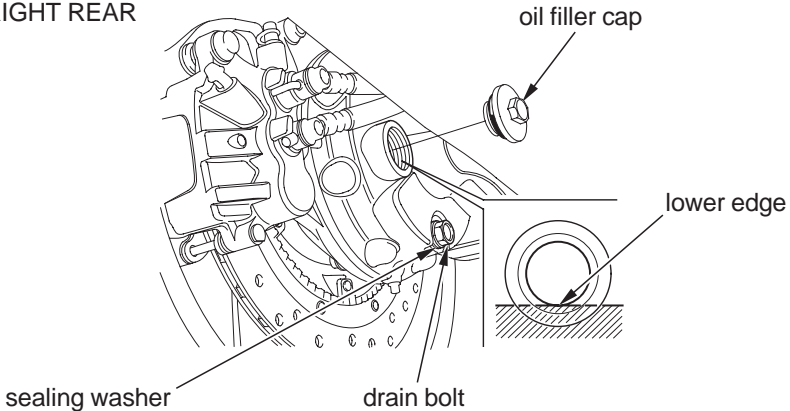

Change the oil with the final drive at normal operating temperature to assure complete and rapid draining.

1. Place the motorcycle on its center stand on a firm, level surface.
2. Place a drain pan under the drain bolt.
3. Remove the oil filler cap, drain bolt and sealing washer.
4. After the oil has completely drained, check that the sealing washer is in good condition. Reinstall the drain bolt with its sealing washer (or a new washer, if necessary) and tighten it to the specified torque:
15 lbf·ft (20 N·m , 2.0 kgf·m)
5. Pour the drained oil into a suitable container and dispose of it in an approved manner (page 211).

NOTICE

Improper disposal of drained fluids is harmful to the environment.

6. Fill the final drive with the recommended oil:
4.1 US oz (120 cm³)
Make sure the final drive oil level is at the lower edge of the oil filler inspection hole.
7. Install the oil filler cap.

Clutch System

Your motorcycle has a hydraulically-actuated clutch. There are no adjustments to perform, but the clutch system must be inspected periodically for fluid level and leakage.

If the motorcycle creeps or stalls when shifted into gear, or if the clutch slips, causing acceleration to lag behind engine speed, there is probably air in the clutch system. See your Honda dealer to have the air bled out of the system.

Clutch Lever Adjustment

Refer to *Safety Precautions* on page 142.

The distance between the tip of the clutch lever and the grip may be adjusted.

LEFT HANDLEBAR

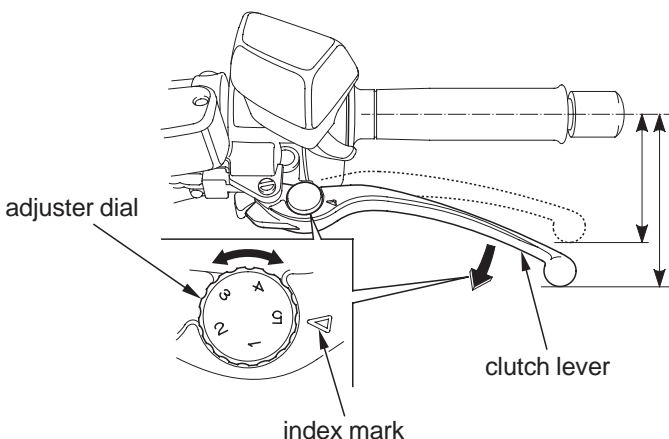

1. Turn the adjuster dial while pushing the clutch lever forward.
2. Align the index mark on the clutch lever with the numbers on the adjuster dial.
3. Start the engine, pull the clutch lever in, and shift into gear. Make sure the engine does not stall and the motorcycle does not creep. Gradually release the clutch lever and open the throttle. Your motorcycle should move smoothly and accelerate gradually.

Clutch System

Fluid Level Inspection

Refer to *Safety Precautions* on page 142.

LEFT HANDLEBAR

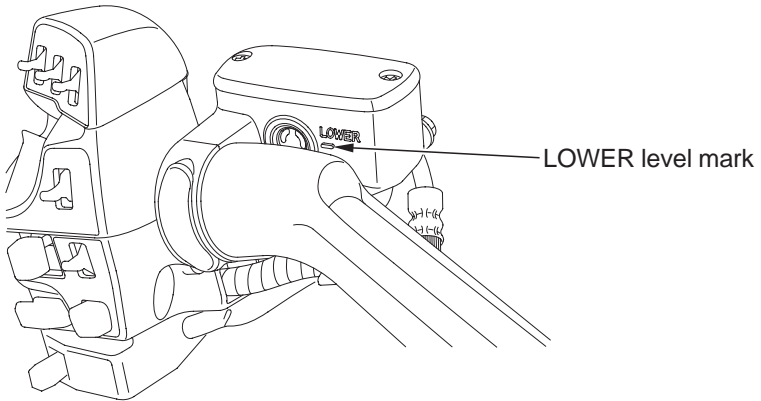

Check that the fluid level is above the LOWER level mark. If the fluid level is below the LOWER level mark, it indicates fluid leakage. See your Honda dealer for repair.

Other Inspections

- Make sure there are no fluid leaks.
- Check for deterioration or cracks in the hose and fittings.
- Check that the clutch lever assembly is positioned properly and the securing bolts are tight.

Spark Plugs

Spark Plug Recommendation

standard spark plug	BKR6E-11 (NGK) or K20PR-U11 (DENSO)
for cold climate (below 5°C, 41°F)	BKR5E-11 (NGK) or K16PR-U11 (DENSO)
for extended high speed riding	BKR7E-11 (NGK) or K22PR-U11 (DENSO)

Use only the recommended type of spark plugs in the recommended heat range.

NOTICE

Using spark plugs with an improper heat range can cause engine damage.

Spark Plug Inspection & Replacement

Refer to *Safety Precautions* on page 142.

1. Remove the left and right cylinder head side cover (page 157).
2. Clean any dirt from around the spark plug bases.
3. Disconnect the spark plug caps. Take care to avoid damaging the spark plug wire when disconnecting the caps.
4. Using a spark plug wrench provided in the tool kit, remove the spark plugs.

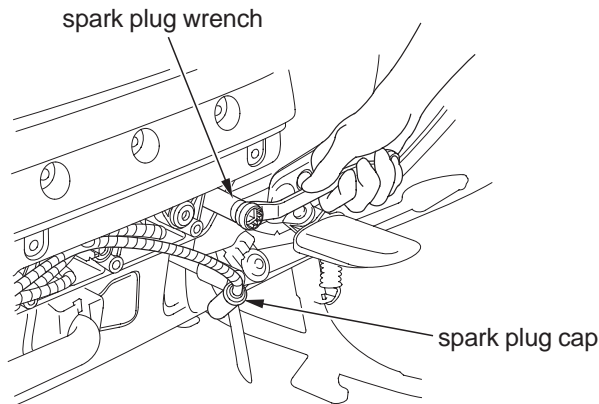

Spark Plugs

5. Inspect the electrodes and center porcelain for deposits, corrosion, or carbon fouling. If the corrosion or deposits are heavy, replace the plug. Clean a carbon or wet-fouled plug with a plug cleaner, if available, or a wire brush.
6. Check the spark plug gap using a wire-type feeler gauge. If adjustment is necessary, bend the side electrode carefully.

The gap should be:

0.039–0.043 in (1.00–1.10 mm)

7. With the plug washers attached, install the spark plugs in by hand to prevent cross-threading.
8. Tighten each spark plug:
 - If the old plug is good:
 - 1/8 turn after it seats.
 - If installing a new plug, tighten it twice to prevent loosening:
 - a) First, tighten the plug:
 - NGK: 3/4 turn after it seats.
 - DENSO: 1/2 turn after it seats.
 - b) Then loosen the plug.
 - c) Next, tighten the plug again:
 - 1/8 turn after it seats.

NOTICE

An improperly tightened spark plug can damage the engine. If a plug is too loose, a piston may be damaged. If a plug is too tight, the threads may be damaged.

9. Reinstall the spark plug caps. Take care to avoid pinching any cables or wires.
10. Reinstall the left and right cylinder head side covers.

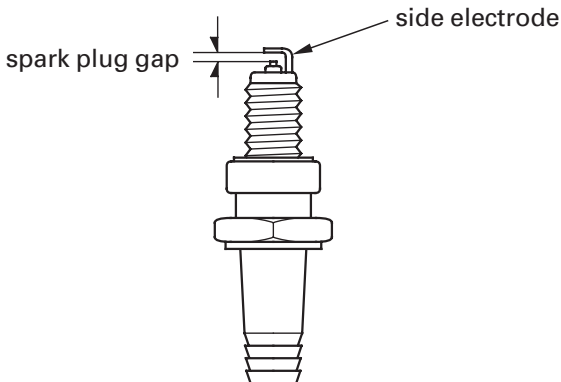

Suspension

Your front and rear suspension systems use springs and hydraulic damping devices that suspend your weight and most of the weight of your motorcycle.

The spring pre-load for your rear suspension system adjusts the amount of force required to begin compression of the spring.

The oil damper systems hydraulically control the natural compression and rebound of the suspension springs so that traction and comfort are maintained as the wheels ride over road surfaces.

Consider adjusting your rear suspension pre-load whenever you change your normal load, when adding or subtracting a passenger, cargo, or accessories, or when the road or riding conditions change.

The way you ride your motorcycle and the type of ride you want to experience can also influence your suspension needs.

Lower spring pre-load provides a softer ride and is usually preferred for light loads and smooth roads. Higher spring pre-load provides a firmer ride and is recommended for heavy loads, rough road conditions, and faster, more challenging riding.

Rear Suspension Adjustment

The rear suspension can be adjusted for rider (and passenger) weight and riding conditions by changing the spring pre-load.

Do not attempt to disassemble, service, or dispose of the damper; see your Honda dealer. The instructions found in this owner's manual are limited to adjustments of the shock assembly only.

Rear Suspension Spring Pre-load Adjustment

Rear suspension spring pre-load can be easily increased or decreased using the rear suspension spring pre-load adjustment switch on the left fairing panel. Then you can confirm the pre-load position with the multi information display.

This rear suspension spring pre-load adjustment system functions only when the ignition switch is ON or ACC, your motorcycle is stopped, and the transmission is in neutral. (When the reverse indicator is ON, the system will not function.)

Suspension

The rear suspension spring pre-load adjustment system has 26 positions (from 0 to 25) for different road or riding conditions. (Standard position is 0.)

Adjustment

1. Place the motorcycle on its center stand on a firm, level surface. To prevent discharging the battery, make sure the audio system and other electrical accessories are off.
2. Turn the ignition switch to ON or ACC.
3. Push the DOWN or UP side of rear suspension spring pre-load adjustment switch until the desired pre-load is reached.

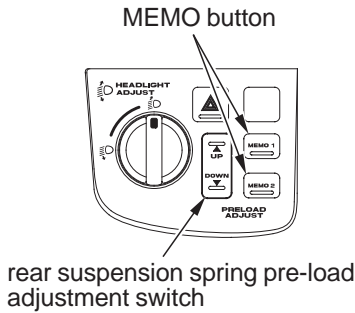

To increase (HIGH)

(Models not equipped with Navigation System)



(Models equipped with Navigation System)

For USA

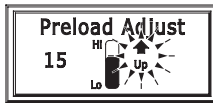

For Canada

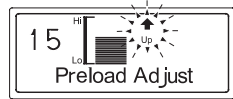

To decrease (LOW)

(Models not equipped with Navigation System)



(Models equipped with Navigation System)

For USA



For Canada

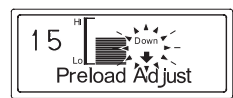

Suspension

Storing Pre-load Into the Memory

You may store two selected adjustments in “MEMO 1” or “MEMO 2”.

1. Adjust the pre-load to the desired position.
2. Push and hold the MEMO 1 or MEMO 2 button until “STORE MEMO 1” or “STORE MEMO 2” blinks in the multi information display. When the blinking stops, the current position is stored in memory.

Storing

Stored

(Models not equipped with Navigation System)



(Models equipped with Navigation System)

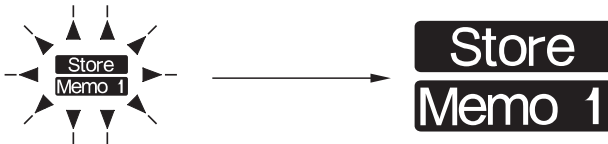

Selecting the Memorized Position

- Push the MEMO (1 or 2) button to select the memorized position. “CALL MEMO 1” or “CALL MEMO 2” will blink. When the position is selected, “MEMO 1” or “MEMO 2” will turn on.

Calling

Called

(Models not equipped with Navigation System)

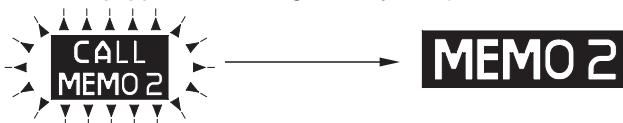

(Models equipped with Navigation System)



Pushing the rear suspension spring pre-load adjustment switch or the MEMO (1 or 2) button while selecting a memorized position will cancel the calling procedure.

Suspension

Each MEMO button stores only one pre-load position. Storing a new position erases the previous setting stored in that button's memory. If you want to add a new position while retaining the current one, use the other memory button.

All stored pre-load positions will be lost if your motorcycle's battery goes low (or dead) or is disconnected.

If "SUS ADJ ERROR" blinks on the display, contact your Honda dealer.

(Models not equipped with Navigation System)



(Models equipped with Navigation System)

For USA



For Canada

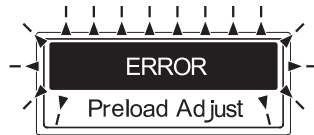

Brakes

The hydraulic braking systems on your motorcycle dissipate the heat generated by the friction of the brake pads on the brake discs as the wheels are slowed.

As the brake pads wear, the brake fluid level will drop. A leak in the system will also cause the level to drop.

Frequently inspect the system to ensure there are no fluid leaks. Periodically inspect the brake fluid level and the brake pads for wear.

If the brake lever or brake pedal freeplay does not feel within the normal range while riding, check the brake pads for wear (page 187). Worn pads should be replaced. If the pads are not worn beyond the recommended limit, there is probably air in the brake system. See your Honda dealer to have the air bled from the system.

Front Brake Lever Adjustment

Refer to *Safety Precautions* on page 142.

The distance between the tip of the brake lever and the grip may be adjusted.

RIGHT HANDLEBAR

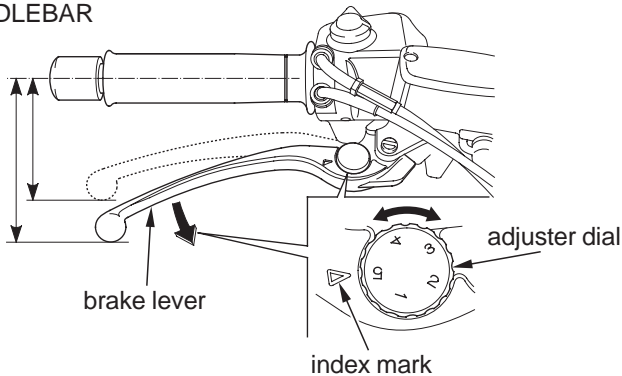

1. Turn the adjuster dial while pushing the brake lever forward.
2. Align the index mark on the brake lever with the numbers on the adjuster dial.
3. Apply the brake, release it, then spin the wheel and check that it rotates freely. Repeat this procedure several times.

Brake Fluid Recommendation

brake fluid	Honda DOT 4 Brake Fluid
-------------	-------------------------

The recommended brake fluid is Honda DOT 4 Brake Fluid, or any brake fluid of equal quality and performance. Use fresh brake fluid from a sealed container. Be sure to read the label before opening the sealed container. An opened container may be contaminated or may have absorbed moisture from the air.

Fluid Level Inspection

Refer to *Safety Precautions* on page 142.

If your inspection indicates a low fluid level, have your Honda dealer add the recommended brake fluid.

Do not add or replace brake fluid, except in an emergency. If you do add fluid, have your Honda dealer check the system as soon as possible.

NOTICE

Brake fluid can damage plastic and painted surfaces. Handle with care.

Wipe up spills immediately. Avoid brake fluid contact with skin or eyes. If it comes in contact with your eyes, wash them out with clean water and immediately call a doctor. If it comes in contact with your skin, wash with clean water and, if necessary, call a doctor.

Brakes

RIGHT HANDLEBAR (Front Brake)

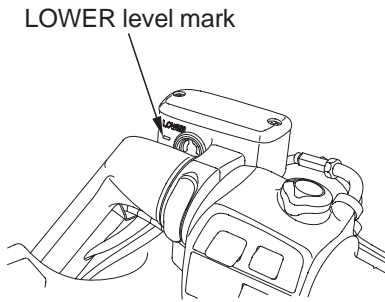

RIGHT SIDE (Rear Brake)

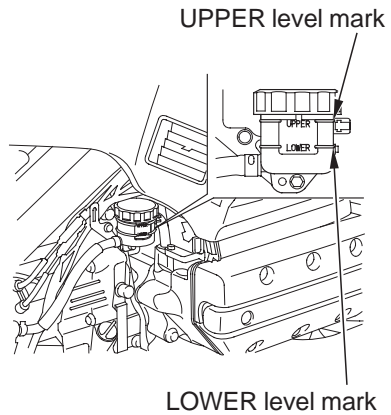

1. Place your motorcycle in an upright position on a firm, level surface.
2. Check the fluid level.
Front: It should be above the LOWER level mark.
Rear: It should be between the UPPER and LOWER level marks.

If the level is at or below the LOWER level mark, check the brake pads for wear.

Worn pads should be replaced. If the pads are not worn beyond the recommended limit, have your brake system inspected for leaks.

Other Inspections

- Make sure there are no fluid leaks.
- Check for deterioration or cracks in the hoses and fittings.

Brake Pad Wear

Refer to *Safety Precautions* on page 142.

Brake pad wear depends upon the severity of usage, the type of riding, and road conditions. Generally, the pads will wear faster on wet and dirty roads. Inspect the pads at each regular maintenance interval (page 147).

Front Brake

LEFT FRONT (right side similar)

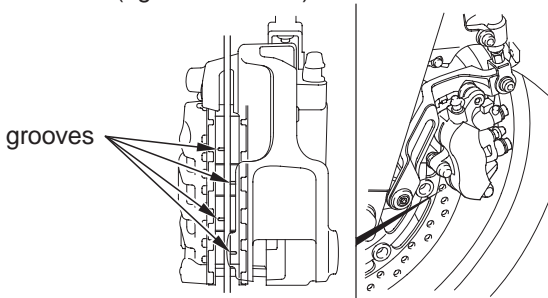

Always inspect both pads in both the right and left front brake calipers.

Check the grooves in each pad. If either pad is worn to the bottom of the grooves, replace both pads as a set. See your Honda dealer for this service.

Rear Brake

RIGHT REAR

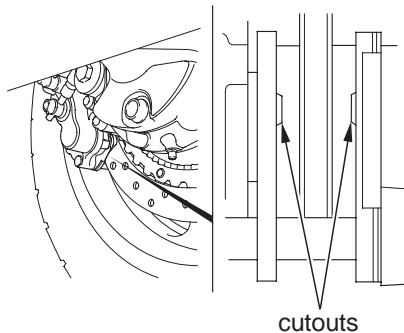

Check the cutouts in each pad. If either pad is worn to the cutout, replace both pads as a set. See your Honda dealer for this service.

Brakes

Brake System Inspection

Refer to *Safety Precautions* on page 142.

1. Place the motorcycle on its center stand, stop the engine, and place the transmission in neutral.
2. Move the left caliper assembly upward while slowly rotating the rear wheel. The brake system is normal if the rear wheel stops. If the rear wheel does not stop, see your Honda dealer.

LEFT FRONT

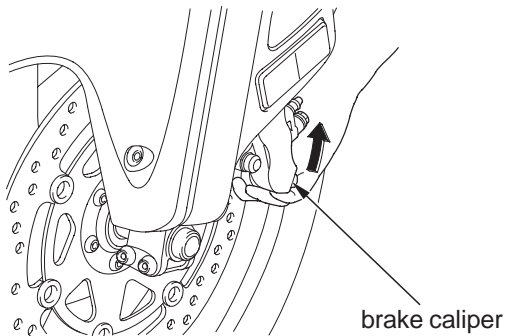

LEFT REAR

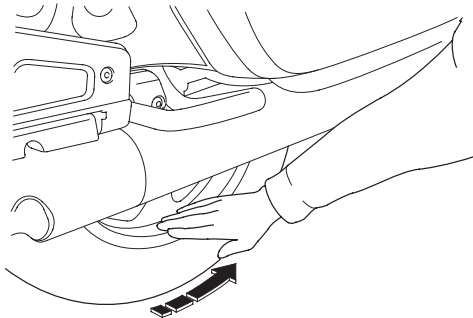

To safely operate your motorcycle, your tires must be the proper type and size, in good condition with adequate tread, and correctly inflated for the load you are carrying.

WARNING

Using tires that are excessively worn or improperly inflated can cause a crash in which you can be seriously hurt or killed.

Follow all instructions in this owner's manual regarding tire inflation and maintenance.

The following pages give detailed information on how and when to check your air pressure, how to inspect your tires for wear and damage, and our recommendations for tire repair and replacement.

Tires

Air Pressure

Refer to *Safety Precautions* on page 142.

Properly inflated tires provide the best combination of handling, tread life, and riding comfort. Generally, underinflated tires wear unevenly, adversely affect handling, and are more likely to fail from being overheated. Overinflated tires make your motorcycle ride harshly, are more prone to damage from road hazards, and wear unevenly.

Even though your motorcycle is equipped with tire pressure monitoring system (TPMS), we recommend that you visually check your tires before every ride and use an air pressure gauge to measure the air pressure at least once a month or any time you think the tires might be low. Even tires that are in good condition may lose one to two psi per month if not checked and adjusted regularly. See page 85 for more information.

Tubeless tires have some degree of self-sealing ability if they are punctured. However, because leakage is often very slow, you should look closely for punctures whenever a tire is not fully inflated.

Always check air pressure when your tires are “cold”, after the motorcycle has been parked for at least three hours. If you check air pressure when your tires are “warm” — even if your motorcycle has only been ridden for a few miles — the readings will be higher. If you let air out of warm tires to match the recommended cold pressures, the tires will be underinflated.

The recommended “cold” tire pressures are:

front	36 psi (250 kPa , 2.50 kgf/cm ²)
rear	41 psi (280 kPa , 2.80 kgf/cm ²)

Inspection

Refer to *Safety Precautions* on page 142.

Whenever you check the tire pressures, you should also look for:

- Bumps or bulges in the side of the tire or the tread. Replace any tire that has a bump or bulge.
- Cuts, slits, or cracks in the tires.
Replace the tire if you can see fabric or cord.
- Nails or other foreign objects embedded in the side of the tire or tread.
- Excessive tread wear.

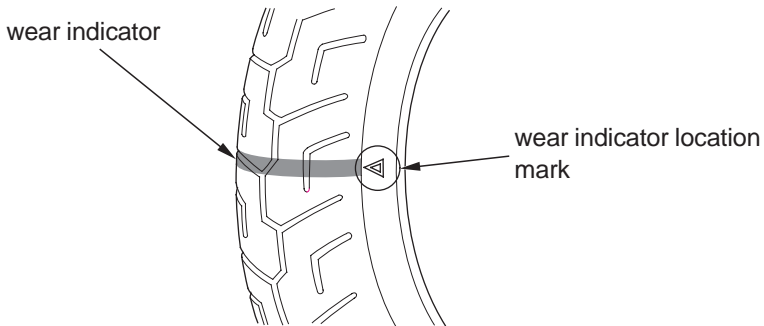

Also, if you hit a pothole or hard object while riding, pull to the side of the road as soon as you safely can and carefully inspect the tires for damage.

For the best performance, you should replace a tire before the tread depth at the center reaches the following limits:

front	0.06 in (1.5 mm)
rear	0.08 in (2.0 mm)

If the wear indicators are visible, replace the tire immediately as it is no longer safe.

Tires

Tire Service Life

The service life of your tires is dependent on many factors, including, but not limited to, riding habits, road conditions, vehicle loading, tire pressure, maintenance history, speed, and environmental conditions (even when the tires are not in use).

In addition to your regular inspections and tire pressure maintenance, it is recommended that you have annual inspections performed once the tires reach 5 years old. It is also recommended that all tires be removed from service after 10 years from the date of manufacture, regardless of their condition or state of wear.

The last four digits of the TIN (tire identification number) (1) are found on the sidewall of the tire, and indicate the date of manufacture.

Tire Identification Number (TIN)

The tire identification number

(TIN) is a group of numbers and letters that look like the following example.

The TIN is located on the sidewall of the tire.

DOT XXXX XXXX 22 07
(2) (3) (4)

DOT — This indicates that the tire meets all requirements of the U.S. Department of Transportation.

- (2) XXXX — Factory code
- (3) XXXX — Tire type code
- (4) 22 07 — Date of manufacture
 - Year
 - Week

TIRE LABELING EXAMPLE

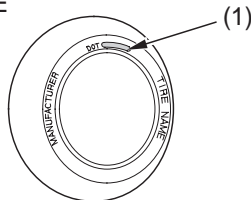

(1) tire identification number (TIN)

Tire Repair

Refer to *Safety Precautions* on page 142.

We strongly recommend that you replace, not repair, any tire that is punctured or damaged. As discussed below, a tire that is repaired, either temporarily or permanently, will have lower speed and performance limits than a new or undamaged tire.

A temporary repair can sometimes be made in an emergency situation. However, since a temporary repair may not hold, you must ride very slowly, preferably without any cargo or passenger, and have the tire replaced or permanently repaired as soon as possible.

(For more information on temporary repairs, see *If You Have a Flat Tire*, page 218 .)

NOTICE

Using a puncture-repairing agent can damage the TPMS sensors, causing the TPMS indicator to turn on. Have your motorcycle checked by your Honda dealer as soon as possible.

Use caution to not damage the TPMS sensor if an internal plug patch must be used to repair the tire. If you have a tire professionally repaired at a non-Honda facility, we recommend that you have the work checked by your Honda dealer. TPMS wheels require special handling when changing the tire. Failure to follow the proper tire replacement procedure can result in damage to the TPMS sensor.

Tires

A permanent repair, such as an internal plug patch, can be made if a tire has only a small puncture in the tread area. With such a repair, you should not exceed 50 mph (80 km/h) for the first 24 hours, or 80 mph (130 km/h) at any time thereafter. In addition, you may not be able to safely carry as much weight. If you choose to have a tire repaired, be sure the repair work is performed by a professional and that the wheel is balanced before you ride.

If you have a tire professionally repaired at a non-Honda facility, we recommend that you have the work checked by your Honda dealer.

Tire Replacement

Refer to *Safety Precautions* on page 142.

The tires that came on your motorcycle were designed to match the performance capabilities of your motorcycle and provide the best combination of handling, braking, durability, and comfort.

When replacing, use the original equipment tires or equivalent tires of the same size, construction, speed rating, and load range as the originals.

WARNING

Installing improper tires on your motorcycle can affect handling and stability. This can cause a crash in which you can be seriously hurt or killed.

Always use the size and type of tires recommended in this owner's manual.

The recommended tires for your motorcycle are:

front	DUNLOP D250F BRIDGESTONE G709 RADIAL	130/70R18M/C 63H
rear	DUNLOP D250 BRIDGESTONE G704 RADIAL	180/60R16M/C 74H
type	radial, tubeless	

Whenever you replace a tire, remember:

- Have the wheel balanced after the tire is installed.
- Have the tire replaced by your Honda dealer.

Important Safety Reminders

- Do not install a tube inside a tubeless tire on this motorcycle. Excessive heat build-up can cause the tube to burst.
- Use only tubeless tires on this motorcycle. The rims are designed for tubeless tires, and during hard acceleration or braking, a tube-type tire could slip on the rim and cause the tire to rapidly deflate.
- Do not install car tires on this motorcycle. During installation the tire may separate from the rim with enough force to cause serious injury or death.
- When replacing tires, use only the recommended tires as shown above and on the tire information label. Use of other tires on the model equipped with ABS may impair proper ABS function. The ABS computer works by comparing wheel speed.

Non-recommended tires can affect wheel speed and may confuse the ABS computer.

- If you ever replace a wheel, make sure that the wheel's specifications match those of the original wheels.

Be sure you use only TPMS-specific wheels. Not using TPMS-specific wheels can cause an air leak, a tire pressure monitoring system failure, or both. Replacement wheels are available at your Honda dealer.

Side Stand

Refer to *Safety Precautions* on page 142.

LEFT SIDE

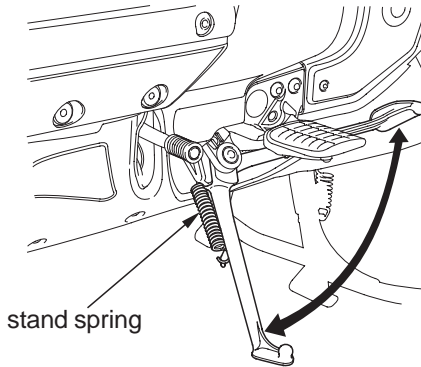

- Check that the side stand assembly is working properly. If the side stand is stiff or squeaky, clean the pivot area and lubricate the pivot bolt with clean grease.
- Check the side stand spring for damage or loss of tension.
- Check the side stand ignition cut-off system:
 1. Sit on the motorcycle and put the transmission in neutral.
 2. Raise the side stand.
 3. Start the engine.
 4. Pull the clutch lever in.
 5. Shift the transmission into gear.
 6. Lower the side stand all the way.

The engine should stop as you lower the side stand. If the engine doesn't stop, see your Honda dealer for service.

Battery

Your motorcycle has a maintenance-free type battery. You do not have to check the battery electrolyte level or add distilled water as you would with a conventional-type battery.

NOTICE

Your battery is a maintenance-free type and can be permanently damaged if the cap strip is removed.

Electrical accessories use current from the battery, even when the ignition is OFF. Limited operation also allows the battery to discharge. If you have electrical accessories on your motorcycle or do not ride frequently, we recommend that you charge the battery frequently (see *Battery Charging*, page 200).

If you do not expect to ride your motorcycle for at least two weeks, we recommend you remove the battery, or at least disconnect the battery cables (negative cable first).

If you plan to store your motorcycle, see *Battery Storage*, page 198 .

If your battery seems weak and/or is leaking electrolyte (causing slow starting or other electrical problems), see your Honda dealer.

WARNING: Battery posts, terminals and related accessories contain lead and lead compounds. **Wash your hands after handling.**

Battery

Battery Storage

Refer to *Safety Precautions* on page 142.

If you plan to store your motorcycle, we recommend you remove the battery and store it where it can be charged at least every 30 days to maintain its service life.

If you do not remove the battery, we recommend disconnecting the battery cables (negative cable first).

You will get the best storage results from removing the battery and slow (trickle) charging it every 30 days (see *Battery Charging*, page 200).

Before you remove the battery, be sure to read all the information that follows, as well as the information on the battery label.

WARNING

The battery gives off explosive hydrogen gas during normal operation.

A spark or flame can cause the battery to explode with enough force to kill or seriously hurt you.

Wear protective clothing and a face shield, or have a skilled mechanic do the battery maintenance.

Battery

The battery is located in the battery box behind the left side cover.

Removal

1. Make sure the ignition switch is OFF.
2. Remove the left side cover (page155).
3. Pull the clip and remove the battery plate.
4. Disconnect the negative (-) terminal lead from the battery first.
5. Remove the bolt and open the battery holder.
6. Disconnect the positive (+) terminal lead.
7. Pull the battery out of the battery box.
Be careful to avoid damaging the cover under the battery box when you remove the battery.
8. Charge the battery (see following section), unless you have been riding regularly.
9. Store your battery in an easy-to-reach location off the floor, in an area protected from freezing temperatures and direct sunlight.
10. Clean the battery box after removing the battery for storage. Dry the battery box and, if paint is missing, re-paint the area.
11. Slow charge the battery (see following section) once every 30 days.

LEFT SIDE

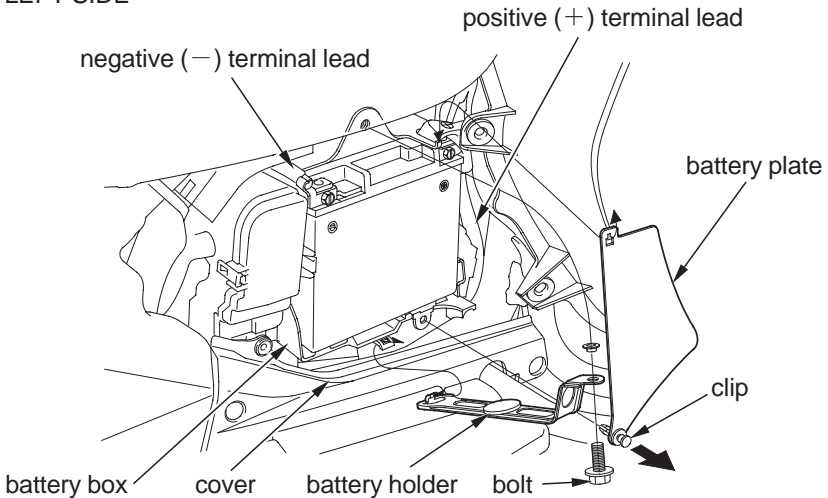

Installation

1. Reinstall in the reverse order of removal. Be sure to connect the positive (+) terminal first, then the negative (-) terminal.
2. Check all bolts and other fasteners are secure.

Battery

Battery Charging

Refer to *Safety Precautions* on page 142.

Be sure to read the information that came with your battery charger and follow the instructions on the battery. Improper charging may damage the battery.

We recommend using a “trickle” charger for home charging. These units can be left connected for long periods without risking damage to the battery. However, do not intentionally leave the charger connected longer than the time period recommended in the charger’s instructions.

Avoid using an automotive-type battery charger. An automotive charger can overheat a motorcycle battery and cause permanent damage.

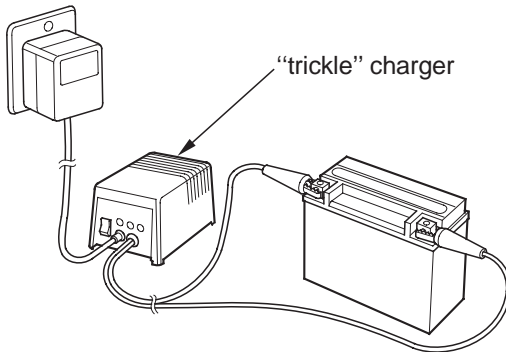

Appearance Care

Frequent cleaning and polishing will keep your Honda looking newer longer. Frequent cleaning also identifies you as an owner who values your motorcycle. A clean motorcycle is also easier to inspect and service.

General Recommendations

Refer to *Safety Precautions* on page 142.

- To clean your motorcycle, you may use:
 - water
 - a mild, neutral detergent and water
 - a mild spray and wipe cleaner/polisher
 - a mild spray and rinse cleaner/degreaser and water
- Avoid products that contain harsh detergents or chemical solvents that could damage the metal, paint, and plastic on your motorcycle.
- If your motorcycle is still warm from recent operation, give the engine and exhaust system time to cool off.
- Park in a shady area. Washing your motorcycle in bright sunlight may cause the finish to fade because water droplets intensify the sun's brightness. Spotting is also more likely because surface water can dry before you have time to wipe it off.
- Clean your motorcycle regularly to protect surface finishes.
- We recommend the use of a garden hose to wash your motorcycle. High pressure washers (like those at coin-operated car washes) can damage certain parts of your motorcycle.

The audio system is designed to be weatherproof unless it is sprayed directly with hose.

NOTICE

High pressure water (or air) can damage certain parts of your motorcycle.

- After cleaning, inspect for damage, wear, and leaks (fuel, oil, coolant, brake, and clutch fluid).

Appearance Care

Washing Your Motorcycle with a Mild Detergent

Refer to *Safety Precautions* on page 142.

1. Rinse your motorcycle thoroughly with cool water to remove loose dirt.
2. Fill a bucket with cool water. Mix in a mild, neutral detergent, such as dish washing liquid or a product made especially for washing motorcycles or automobiles.
3. Wash your motorcycle with a sponge or a soft towel. As you wash, check for heavy grime. If necessary, use a mild cleaner/degreaser to remove the grime.

If the inside of the headlight lens appears clouded immediately after washing, it should clear after a few minutes of riding.

4. After washing, rinse your motorcycle thoroughly with plenty of clean water to remove any residue. Detergent residue can corrode alloy parts.
5. Dry your motorcycle with a chamois or a soft towel. Leaving water on the surface to air dry can cause dulling and water spots. As you dry, inspect for chips and scratches.
6. Start the engine and let it idle for several minutes. The engine heat will help dry moist areas.
7. As a precaution, ride your motorcycle at a slow speed and apply the brakes several times. This will help dry the brakes and restore normal braking performance.

Cleaning the Windscreen

Refer to *Safety Precautions* on page 142.

Using plenty of water, clean the windscreen with a soft cloth or sponge. (Avoid using detergents or any kind of chemical cleaner on the windscreen.) Dry with a soft, clean cloth.

NOTICE

To avoid possible scratching or other damage, use only water and a soft cloth or sponge to clean the windscreen.

For a dirtier windscreen, use a diluted neutral detergent with a sponge and plenty of water. Make sure to wash off all the detergent. (Detergent residue may cause windscreen cracks.)

Replace the windscreen if scratches cannot be removed and they obstruct clear vision.

Take care to keep battery electrolyte, brake fluid, or other chemical solvents off the windscreen and screen garnish. They will damage the plastic.

Cleaning the Display

Clean the display with a soft, damp cloth. You may use a mild cleaner intended for eyeglasses or computer displays.

Harsher chemicals may damage the display.

NOTICE

To avoid possible scratching or other damage, use only water and a soft cloth or sponge to clean the display.

Take care to keep battery electrolyte, brake fluid, or other chemical solvents off the display. They will damage the display.

Appearance Care

Spray Cleaning Your Motorcycle

Refer to *Safety Precautions* on page 142.

Avoid using spray cleaner products on the tires or suspension components.

Suggestions for using spray cleaner(s) follow:

Motorcycle Condition	Recommended Cleaning
General cleaning. Polishing paint, chrome, glass, and clear plastic. Dust. Fingerprint smudges.	Apply a spray cleaner/polish and wipe with a non-abrasive cloth.
Light road grime.	Spray any difficult-to-reach or very dirty areas with a spray cleaner/degreaser. Rinse and dry. Apply a spray cleaner/polish and wipe with a non-abrasive cloth.
Heavy grime. Oil leaks. Brake dust.	Use a spray cleaner/degreaser. If necessary, rub with a sponge. Rinse and dry. Apply a spray cleaner/polish and wipe with a non-abrasive cloth.
Dull, corroded chrome or aluminum.	Apply a high quality chrome/aluminum polish and wipe with a non-abrasive cloth.

Aluminum Wheel Maintenance

Refer to *Safety Precautions* on page 142.

Aluminum may corrode from contact with dirt, mud, or road salt. Clean the wheels after riding through any of these substances. Use a wet sponge and mild detergent, or a commercially-available spray cleaner/degreaser designed for use on aluminum. Avoid stiff brushes, steel wool, or cleaners containing abrasives or harsh chemical compounds.

After washing, rinse with plenty of water and dry with a clean cloth. Then apply a mild, commercially-available spray cleaner/polish or wax.

For stained or dull-looking wheels, use a quality chrome/aluminum polish to restore the finish.

After you finish cleaning the wheels, it's important to check for and remove any cleaner or polish residue found on the brake discs or pads. Use Honda Contact/Brake Cleaner or an equivalent brake degreasing agent.

Clean the Matte Painted Surface

Refer to *Safety Precautions* on page 142.

Use a soft cloth or sponge, plenty of water, and a mild detergent to clean the matte paint. Dry with a soft, clean cloth.

Do not use polishing compounds or wax containing polishing compounds. These can damage or discolor the paint.

To keep your Honda looking new, clean and polish it frequently.

Appearance Care

Finishing Touches

Refer to *Safety Precautions* on page 142.

After washing your motorcycle, consider using a commercially available spray cleaner/polish or quality liquid or paste wax to finish the job. Use only a non-abrasive polish or wax made specifically for motorcycles or automobiles. Apply the polish or wax according to the instructions on the container.

If a surface on your motorcycle is chipped or scratched, your Honda dealer has touch-up paint to match your motorcycle's color. Be sure to use your motorcycle's color code (page 241) when you buy touch-up paint. If the frame has a chip that exposes the metal, first apply primer (to prevent corrosion) and then apply the touch-up paint. Several thin layers of touch-up paint are better than one thick coat.

Tips

Here's a few helpful tips on how to store and transport your Honda, and how to be an environmentally responsible motorcycle owner.

Storing Your Honda	208
Transporting Your Motorcycle	210
You & the Environment	211

Storing Your Honda

If you won't be riding for an extended period, such as during the winter, thoroughly inspect your motorcycle and correct any problem before storing it. That way, needed repairs won't be forgotten and it will be easier to get your motorcycle running again.

For more information about storage, refer to the *Honda Motorcycle Winter Storage Guide*, available from your Honda dealer (USA only).

We suggest you perform the following procedures to keep your motorcycle in top condition. These storage procedures will reduce the deterioration that can occur during storage.

Preparation for Storage

Refer to *Safety Precautions* on page 142.

This procedure requires a means for draining and disposing of drained fuel (page 211).

1. Change the engine oil and filter (page 167).
2. Make sure the cooling system is filled with a 50/50% antifreeze solution (page 170).
3. Fill the fuel tank. Make sure the fuel fill cap is properly installed.
4. To prevent rusting in the cylinders, perform the following:
 - Remove the spark plug caps from the spark plugs. Using tape or string, secure the caps to any convenient plastic body part so that they are positioned away from the spark plugs.
 - Remove the spark plugs from the engine and store them in a safe place. Do not connect the spark plugs to the spark plug caps.

Storing Your Honda

- Pour a tablespoon (15 – 20 cc) of clean engine oil into each cylinder and cover the spark plug holes with a piece of cloth.
 - With the engine stop switch in the RUN position, press the start button several times to crank the engine and distribute the oil.
 - Reinstall the spark plugs and spark plug caps.
5. Remove the battery and charge it fully. Store it in an area protected from freezing temperatures and direct sunlight. Slow charge the battery (page 200) once a month.
 6. Wash and dry your motorcycle. Wax all painted surfaces. Apply rust-inhibiting oil to the chrome pieces.
 7. Inflate the tires to their recommended pressures (page 200).
 8. Store your motorcycle in an unheated area, free of dampness, away from sunlight, with a minimum of daily temperature variation.
 9. Cover your motorcycle with a porous material. Avoid using plastic or similar non-breathing, coated materials that restrict air flow and allow heat and moisture to accumulate.

Removal from Storage

Refer to *Safety Precautions* on page 142 .

1. Uncover and clean your motorcycle.
2. If your motorcycle has been stored for more than four months — change the engine oil (page 167).
3. If your motorcycle has been stored for more than two months — ask your Honda dealer to drain and replace the fuel.
4. Charge the battery (page 200) as required. Install the battery.
5. Perform a pre-ride inspection (page 47), then test-ride your motorcycle at low speeds.

Transporting Your Motorcycle

If your motorcycle needs to be transported, it should be carried on a motorcycle trailer, or a truck or trailer with a flatbed area. Do not tow your motorcycle, as towing can seriously damage the transmission.

When contacting a towing or transporting service, be sure to ask if they have a flatbed area, a loading ramp or power ramp to safely lift the motorcycle, and motorcycle tie-down straps.

You & the Environment

Owning and riding a motorcycle can be enjoyable, but you must do your part to protect nature.

Following are tips on how you can be an environmentally responsible motorcycle owner.

- **Choose Sensible Cleaners.** Use a biodegradable detergent when you wash your motorcycle. Avoid aerosol spray cleaners that contain chlorofluorocarbons (CFCs) which damage the atmosphere's protective ozone layer. Don't throw cleaning solvents away; see the following guidelines for proper disposal.
- **Recycle Wastes.** It's illegal and thoughtless to put used engine oil in the trash, down a drain, or on the ground. Used oil, gasoline, coolant, and cleaning solvents contain poisons that can hurt refuse workers and contaminate our drinking water, lakes, rivers, and oceans. Before changing your oil, make sure you have the proper containers. Put oil and other toxic wastes in separate sealed containers and take them to a recycling center. Call your local or state office of public works or environmental services to find a recycling center in your area, and to get instructions on how to dispose of non-recyclable wastes.

Taking Care of the Unexpected

This section discusses the more common problems that can occur with your motorcycle while you're riding. It tells you how to evaluate each problem and what actions you can take to try to resume riding. If the problem cannot be safely solved, this section also gives instructions on the proper way to have your motorcycle transported.

For information about transporting your motorcycle, see page 210 .

General Guidelines.....	214
If Your Engine Quits or Won't Start.....	215
If You Have a Flat Tire.....	218
If Your Engine Overheats.....	229
If the Low Oil Pressure Indicator Lights.....	231
If a Fuse Blows.....	232
If You Crash.....	235
If You Lose Your Key.....	236
If Your Battery Is Low (or Dead).....	237

Taking Care of the Unexpected

General Guidelines

Keeping your motorcycle well-maintained is the best way to reduce the possibility of having a problem on the road.

Remember to take along your owner's manual, the tool kit that came with your motorcycle, and any other items (such as tire repair supplies and additional tools) that might help you solve a problem on your own.

Should you ever have a problem while riding, please follow these guidelines:

- Always put personal safety first.
- Take time to assess the situation and your options before deciding what to do.
- If the problem is relatively minor and you have the tools, supplies, and skills to make a temporary repair, be sure to have permanent repairs made as soon as possible.
- Do not continue riding if you are hurt or your motorcycle is not in safe riding condition.

Additional recommendations for specific problems follow.

If Your Engine Quits or Won't Start

Proper operation and maintenance can prevent starting and engine performance problems. In many cases, the cause of the problem may be a simple operational oversight.

If you have a problem starting the engine — or experience poor engine performance — the following information may help you. If you can't correct the problem, see your Honda dealer.

If your motorcycle won't start, listen as you press the start button. If you don't hear the starter motor turning, refer to the *Starter motor doesn't operate* symptom. If you can hear the starter motor working normally, refer to the *Starter motor works, but the engine won't start* symptom.

SYMPTOM: Starter motor doesn't operate.	
POSSIBLE CAUSE	WHAT TO DO
ignition switch OFF	Turn the ignition switch ON.
engine stop switch OFF	Turn the engine stop switch to RUN.
transmission not in neutral	Shift into neutral.
reverse (RVS) switch ON	Push the reverse (RVS) switch to the OFF position.
side stand down (when transmission not in neutral)	Put the transmission in neutral or raise the side stand and pull the clutch lever in.
blown fuse	Replace with a new fuse of the same rating (page 232).
battery lead loose	Tighten the battery lead.
low (or dead) battery	Charge the battery (page 200). If charging doesn't help, see your Honda dealer.
faulty starter motor	If all possible causes are negative, the starter motor may be faulty. See your Honda dealer.

If Your Engine Quits or Won't Start

SYMPTOM: Starter motor works, but the engine won't start.	
POSSIBLE CAUSE	WHAT TO DO
out of fuel	Fill the fuel tank.
flooded engine	See <i>Flooded Engine</i> (page 74).
loose or unconnected spark plug caps	Install the spark plug caps securely. If the engine still won't start, see your Honda dealer.
loose battery cables	Tighten the battery terminal bolts.
weak battery	Charge the battery (page 200). If charging doesn't help, see your Honda dealer.

SYMPTOM: Engine starts, but stalls as you shift into gear.	
POSSIBLE CAUSE	WHAT TO DO
side stand down	Raise the side stand. Start again.

If Your Engine Quits or Won't Start

SYMPTOM: Engine starts, but runs poorly.	
POSSIBLE CAUSE	WHAT TO DO
idles roughly, too fast, stalls	See your Honda dealer.
overheating	Check the coolant temperature gauge. Refer to <i>If Your Engine Overheats</i> , page 229.
low oil pressure	Check the low oil pressure indicator. Refer to <i>If the Low Oil Pressure Indicator Lights</i> , page 231.
runs erratically, misfires	May damage catalytic converters. See your Honda dealer.
blubbers (rich fuel mixture)	See your Honda dealer.
sooty exhaust (rich fuel mixture)	See your Honda dealer.
detonates or pings under load	If applicable, switch to the recommended octane gasoline (page 160) or change your brand of gasoline. If the problem persists, see your Honda dealer.
afterfires (backfires)	May damage catalytic converters. See your Honda dealer.
pre-ignition (runs on after ignition switched OFF)	May damage catalytic converters. See your Honda dealer.

If You Have a Flat Tire

A flat tire is always unwelcome, especially if you are far from help. If you think you are losing air, or you hit a pothole or hard object, pull safely to the side of the road so you can inspect the tires and assess the situation. (Be sure to park on a firm, level surface and use the center stand for support.) You should examine the tire treads and sidewalls for foreign objects or damage. If you find a tire that has been punctured or damaged, you have two options.

Option 1:

Have Your Motorcycle Transported

If a tire has a major puncture or a cut in the tread or sidewall, or the bead has come loose from the rim, there is probably not much you can do except have your motorcycle transported to a Honda dealer or other qualified service facility. Even with a simple puncture, this may be the safest and least troublesome solution. For transporting instructions, see page 210.

Option 2:

Make a Temporary Roadside Repair

If a tire has only a minor nail puncture and is not completely flat, you may be able to make an emergency repair that could allow you to continue riding to where you can get the tire replaced or permanently repaired.

WARNING

Riding your motorcycle with a temporary tire repair can be risky. If the temporary repair fails, you can crash and be seriously injured or killed.

If you must ride with a temporary tire repair, ride slowly and carefully and do not exceed 30 mph (50 km/h) until the tire is permanently repaired or replaced.

If You Have a Flat Tire

Due to the uncertainty of any temporary repair, you should ride slowly (not over 30 mph, 50 km/h) and carefully (preferably without a passenger or cargo) until the tire is replaced or permanently repaired. Stop frequently and check the air pressure. If the tire is losing pressure, it may be unsafe to continue riding. As the tire gets low, it will affect the handling of your motorcycle (especially with a passenger and cargo), and it may overheat and blow out.

Types of Temporary Repairs

The following types of temporary repairs generally require a source of air to inflate the tire. Possible sources include CO₂ cartridges or cans of compressed air designed to inflate a tire.

For more information on tire repair, see page 193 .

- **Inflate the tire:** Tubeless tires have some self-sealing ability if they are punctured and the result is usually just a slow leak. If this is the case, you can try inflating the tire to see if it will hold air pressure. If you can see a nail or other object embedded in the tire tread, do not remove it at this time.
- **Plug the hole:** The idea here is to do something to temporarily stop the leak. If you have a tubeless tire repair kit, you can pull out the nail and try inserting an external plug in the puncture. Follow the instructions that came with the repair kit and be sure to inflate the tire to the correct pressure.

NOTICE

Using a puncture-repairing agent can damage the TPMS sensors, causing the TPMS indicator to turn on. Have your motorcycle checked by your Honda dealer as soon as possible.

Use caution to not damage the TPMS sensor if an internal plug patch must be used to repair the tire. If you have a tire professionally repaired at a non-Honda facility, we recommend that you have the work checked by your Honda dealer. TPMS wheels require special handling when changing the tire. Failure to follow the proper tire replacement procedure can result in damage to the TPMS sensor.

If You Have a Flat Tire

Should You Repair or Replace a Tire?

We strongly recommend that you replace, not permanently repair, any tire that is punctured or damaged, even if the tire has only a minor puncture. For a full discussion of repairs and replacement, see page 193.

Emergency Front Wheel Removal/Installation

Refer to *Safety Precautions* on page 142.

We recommend wheel removal be done only by your Honda dealer or another qualified mechanic. Do not attempt to remove the wheel on your own. Wheel removal requires mechanical skill and professional tools.

Removal

1. Park your motorcycle on a firm, level surface.
2. Raise the front wheel off the ground by placing a support block under the engine, being careful to avoid contact with the exhaust pipe and front lower cover.
3. Remove the parts in sequence, according to the order in the illustration.
 - When removing and installing the wheel, be careful not to damage the sensor and pulser ring. (Models equipped with ABS)
 - To avoid damage to the brake hose during removal, support the caliper assembly so that it doesn't hang from the hose. Do not twist the brake hose. Avoid getting grease, oil, or dirt on the disc or pad surfaces. Any contamination can cause poor brake performance or rapid pad wear after reassembly.
 - Avoid depressing the brake lever and brake pedal when the wheel is off the motorcycle. This will force the caliper pistons out of the cylinders. The result will be a loss of brake fluid. If this occurs, the brake system will require service.
See your Honda dealer for this service.

If You Have a Flat Tire

For related torque specifications, see page 223. Cover both sides of the front wheel with protective tape or an equivalent. The numbers indicate the disassembly sequence.

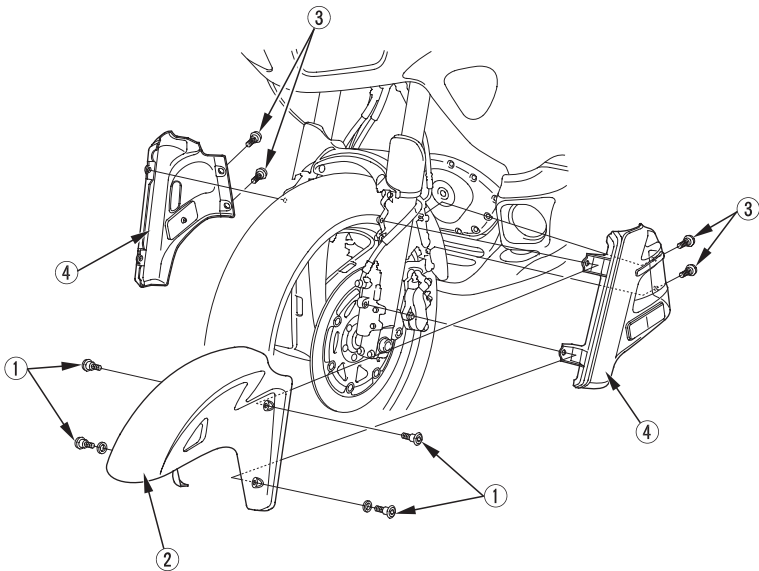
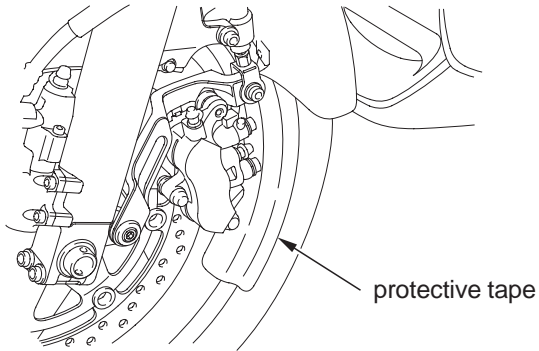

If You Have a Flat Tire

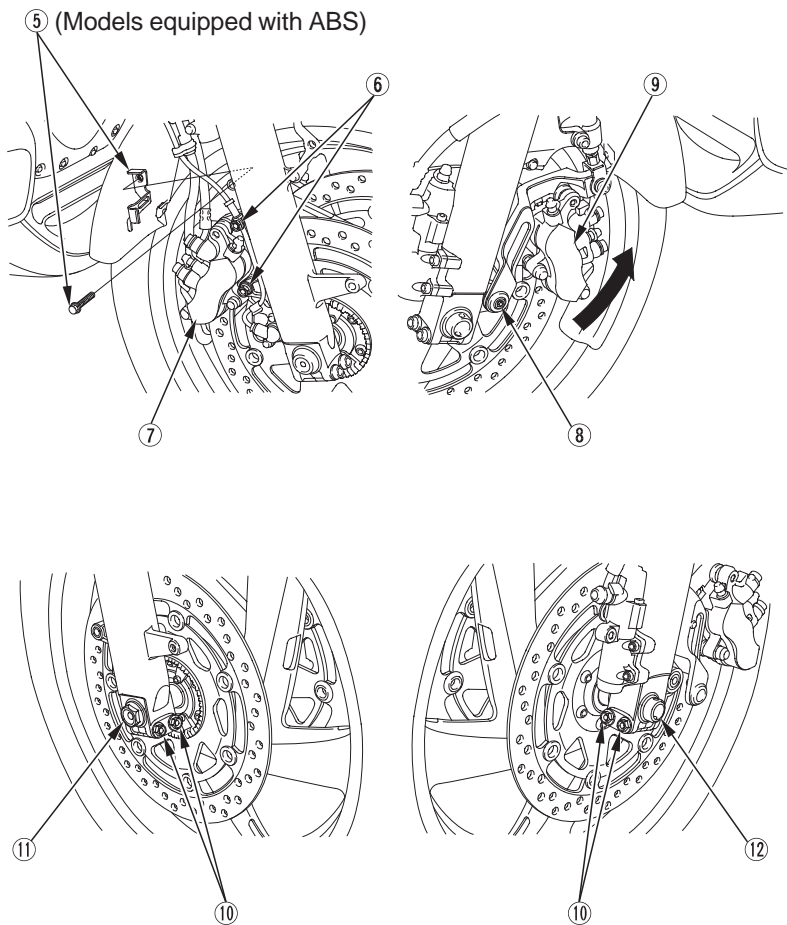

If You Have a Flat Tire

Installation

1. Reassemble the removed parts in the reverse order of removal.

- Position the wheel between the fork legs and insert the front axle shaft from the left side, through the left fork leg and wheel hub.
- Align the index line of the front axle shaft with the recessed surface of the fork leg.

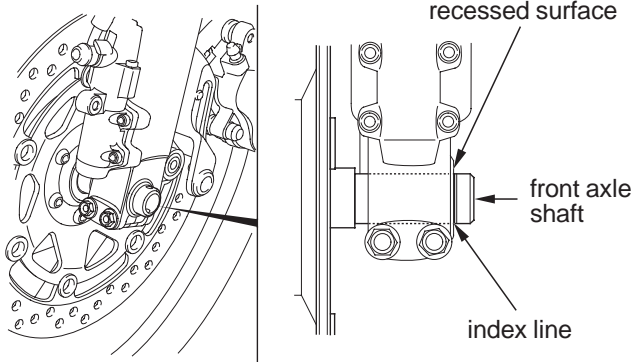

- Fit the brake disc carefully between the brake pads to avoid damaging the pads.

2. Install the bolts and tighten to the specified torque:

axle bolt:

44 lbf·ft (59 N·m , 6.0 kgf·m)

right caliper fixing bolts:

23 lbf·ft (31 N·m , 3.2 kgf·m)

left caliper socket bolt:

23 lbf·ft (31 N·m , 3.2 kgf·m)

3. Measure the clearance between the brake disc and the caliper holder on each side with a 0.028 in (0.7 mm) feeler gauge.

- If the feeler gauge inserts easily, remove it and tighten the axle pinch bolts to the specified torque:

16 lbf·ft (22 N·m , 2.2 kgf·m)

- If the feeler gauge cannot be inserted easily, loosen the left axle pinch bolt and pull the left fork outward or push inward to adjust the clearance. Then tighten the axle pinch bolts to the specified torque. (cont'd)

If You Have a Flat Tire

Failure to provide adequate disc-to-caliper holder clearance may damage the brake discs and impair braking efficiency.

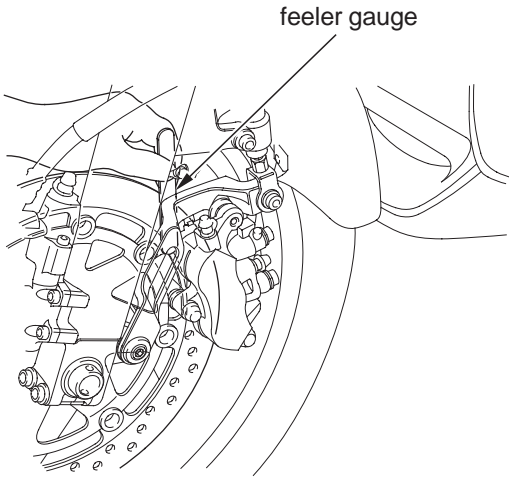

If You Have a Flat Tire

4. After installing the wheel, apply the brake lever AND brake pedal several times, then recheck both discs for caliper holder to disc clearance. Do not operate the motorcycle without adequate clearance.

- Check for free wheel rotation after the brake lever and brake pedal are released. Recheck the wheel if the brake drags or if the wheel does not rotate freely.
- After installing the wheel, operate the brake lever AND brake pedal several times until you feel pressure. You must restore pressure from BOTH the lever AND the pedal because this motorcycle is equipped with a Linked Braking System.
- Verify proper brake operation before riding.

5. Remove the protective tapes from the front wheel.

If a torque wrench was not used for installation, see your Honda dealer as soon as possible to verify proper assembly. Improper assembly may lead to loss of braking capability.

If You Have a Flat Tire

Emergency Rear Wheel Removal/Installation

Refer to *Safety Precautions* on page 142.

We recommend wheel removal be done only by your Honda dealer or another qualified mechanic. Do not attempt to remove the wheel on your own. Wheel removal requires mechanical skill and professional tools.

Removal

1. Park your motorcycle on its center stand on a firm, level surface.
2. Remove the parts in sequence, according to the order in the illustration.
 - Avoid getting grease, oil, or dirt on the disc or pad surfaces. Any contamination can cause poor brake performance or rapid pad wear after reassembly.
 - When removing and installing the wheel, be careful not to damage the sensor and pulser ring. (Models equipped with ABS)

(Models not equipped with Premium Audio)

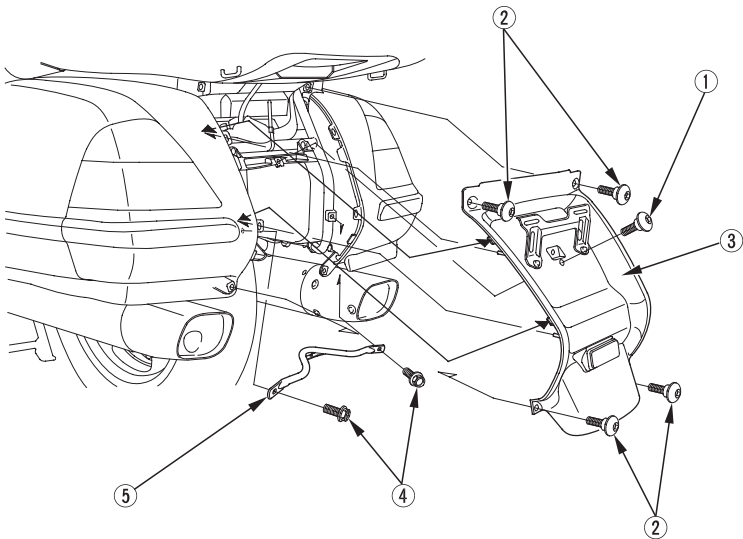

If You Have a Flat Tire

(Models equipped with Premium Audio)

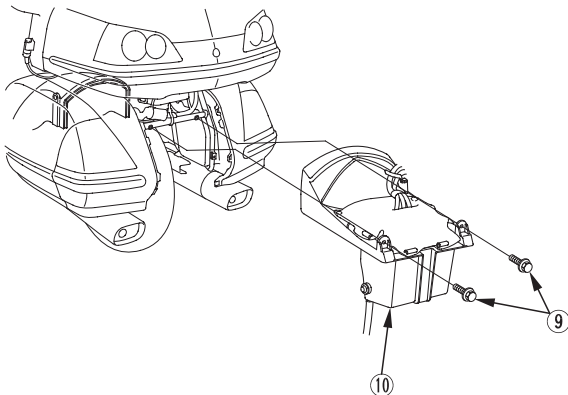
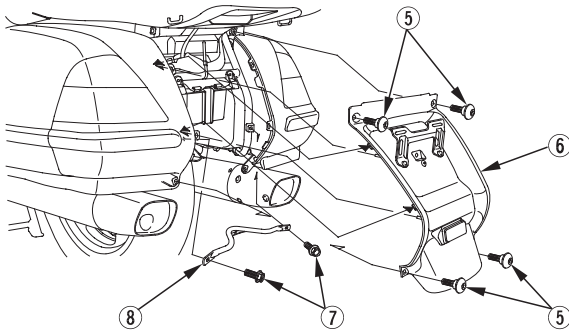
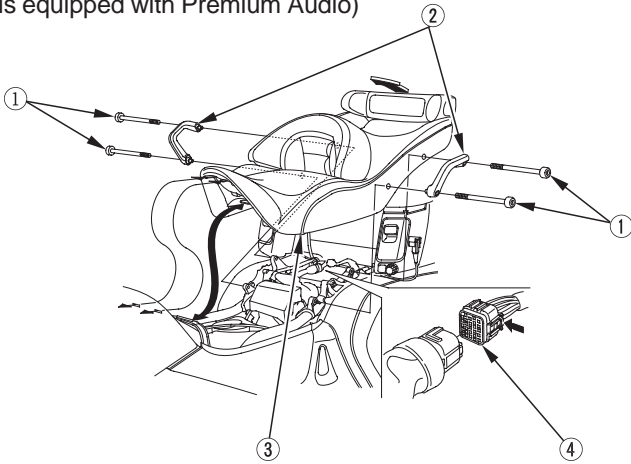

If You Have a Flat Tire

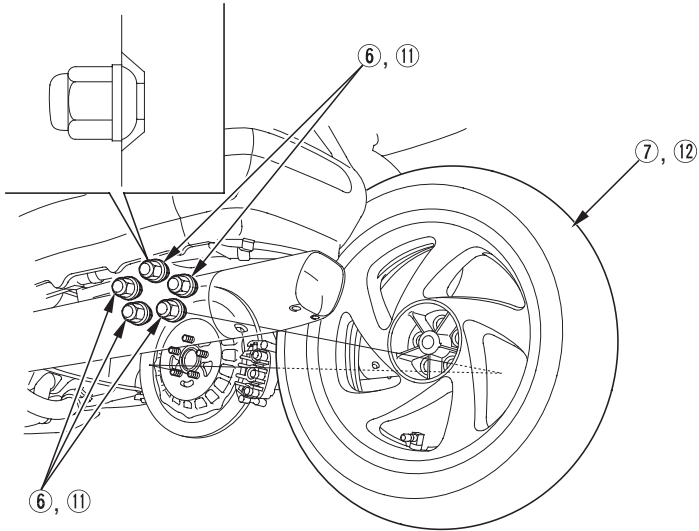

⑥, ⑦: (Models not equipped with Premium Audio)
⑪, ⑫: (Models equipped with Premium Audio)

Installation

1. Reassemble the removed parts in the reverse order of removal.
2. Tighten the rear wheel nuts to the specified torque:
80 lbf·ft (108 N·m , 11.0 kgf·m)
3. After installing the wheel, apply the brake several times and then check if the wheel rotates freely. Recheck the wheel if the brake drags or if the wheel does not rotate freely.
4. Operate the brake pedal and check the brake operation.
5. Inspect the brake system (page 184).

If a torque wrench was not used for installation, see your Honda dealer as soon as possible to verify proper assembly. Improper assembly may lead to loss of braking capability.

If Your Engine Overheats

Normally, the needle on your temperature gauge will rise to a point about midway between C (cold) and H (hot) and then level off. Hot weather may cause the needle to rise higher than normal. So will temporary stress such as climbing a hill. If you're stuck in stop-and-go traffic, the needle may climb some, but the radiator fan is designed to prevent overheating. Be aware of these variations as you monitor the gauge.

- If your vehicle is operated at sustained speeds between 10 and 15 miles per hour in high ambient temperature conditions, you may experience high temperature gauge readings.
- If the temperature gauge rises, shifting to second gear or altering your speed (either faster or slower) may reduce the temperature reading. If the indicator reaches the red zone, as soon as it is safe to do so, pull over and let the engine idle until the indicator drops.

NOTICE

Continuing to ride with an overheated engine can cause serious engine damage.

- A steaming engine indicates a coolant leak. Shut the engine off and wait until the steaming stops. Look for a leak, but don't touch the engine or radiator system. Let everything cool off first.
- If there's no obvious problem, leave the engine on so the fan and coolant circulating system can continue working. Monitor the temperature gauge. The needle may drop to the normal range after a brief stop with no load on the engine.
- Check the radiator fan.

If the fan is not working, turn the engine off. Open the fuse box (page 232) and check the radiator fan fuse. If the fuse is blown, replace it with the proper (same rating) spare fuse. Start the engine. If the needle climbs to the red zone and stays there, turn the engine off.

If the radiator fan is working, visually check the coolant level in the reserve tank, located behind the left engine side cover. It isn't necessary to touch the radiator system.

(cont'd)

If Your Engine Overheats

- If the reserve tank is low or empty, don't ride without adding coolant (page 171). After adding coolant, turn the engine on and check the temperature gauge.
If the needle doesn't drop, do not ride. The engine needs repair. Transport your motorcycle to a Honda dealer (page 210).
If the temperature drops to normal, check the coolant level. If it has gone down, add more coolant.

If you are able to resume riding, continue to monitor the gauge frequently.

If there's a mild leak, you can ride for awhile, carefully watching the gauge. Be prepared to stop and add more coolant or water. If the leak is bad, transport your motorcycle to a Honda dealer (page 210).

If the Low Oil Pressure Indicator Lights

If you check your engine oil level regularly, you should never see the low oil pressure indicator while riding. Normally, it will only light momentarily when you turn the ignition switch ON. Occasionally, it may flicker at or near idling speed.

Low oil pressure may be caused by an oil leak, a low oil level, or some problem in the engine's lubrication system.

If the indicator comes on while you're riding, don't ignore it. Pull safely to the side of the road. If possible, pull the clutch lever in and coast to a stop. Stop the engine as soon as it's safe to do so.

NOTICE

Continuing to ride with low oil pressure can cause serious engine damage.

- Check for an oil leak.
- Then check the oil level. If necessary, add the recommended oil (page 166) to the upper level mark. If you must leave your motorcycle to get oil, secure it as much as possible.
- After adding oil, start the engine, and check that the low oil pressure indicator goes off. Check for a possible leak.

If the indicator goes off and there is no leak — resume riding. If there is a leak — do not ride the motorcycle until the leak is repaired by a Honda dealer.

If a Fuse Blows

All of the electrical circuits on your motorcycle have fuses to protect them from damage caused by excess current flow (short circuit or overload).

If something electrical on your motorcycle stops working, the first thing you should check for is a blown fuse.

Determine from the chart on the circuit fuse box cover which fuse or fuses control that component. Check those fuses first, but check all the fuses before looking elsewhere for another possible cause of the problem. Replace any blown fuses and check component operation.

- The circuit fuse box (including spare fuses) is located behind the left side cover.
- The main fuse is located in the fuse box.

Recommended Fuses

main fuse A	30 A
main fuse B	120 A
speed limiter fuse	60 A
external amplifier fuse (models equipped with Premium Audio)	40 A
other fuses	30 A, 20 A, 15 A, 10 A, 5 A

1. To prevent an accidental short circuit, turn the ignition switch OFF before checking or replacing the fuses.
2. Remove the left side cover (page 155).
3. Remove the fuse box cover.

LEFT SIDE

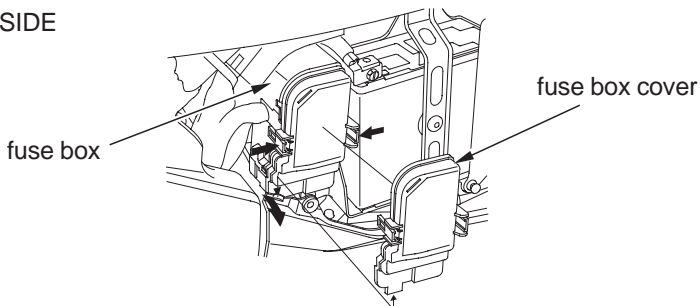

If a Fuse Blows

Main Fuse Access:

4. Check the two main fuses (A & B) to see if they are blown.
To replace main fuses (A & B), see your Honda dealer for this service.

Speed Limiter Fuse Access:

5. Check the speed limiter (reverse system) fuse to see if it's blown, see your Honda dealer for this service.

Circuit Fuses Access:

6. To check or replace a circuit fuse, pull the old fuse out of its retaining clips with the fuse remover. Look for a burned wire inside the fuse. If the fuse is blown, replace it with a spare fuse of the same rating.

If you do not have a replacement fuse with the proper rating for the circuit, install one with a lower rating.

NOTICE

Replacing a fuse with one that has a higher rating greatly increases the chance of damage to the electrical system.

External Amplifier Fuse Access:

7. To replace the external amplifier fuse, see your Honda dealer for this service.

(cont'd)

If a Fuse Blows

LEFT SIDE

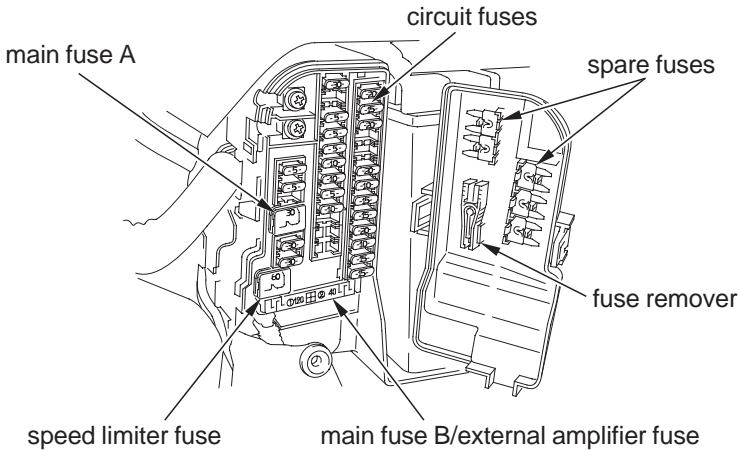

8. Close the fuse box cover.

9. Install the left side cover.

If you do not have a spare fuse and you cannot ride the motorcycle without fixing the problem, take a fuse of the same rating or a lower rating from one of the other circuits that you can do without temporarily.

If you replace a blown fuse with a spare fuse that has a lower rating, replace the fuse with the correct rating as soon as you can. Also remember to replace any spare fuses that were installed.

If the replacement fuse of the same rating burns out in a short time, there is probably a serious electrical problem on your motorcycle. Leave the blown fuse in that circuit and have your motorcycle checked by your Honda dealer.

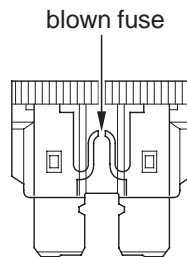
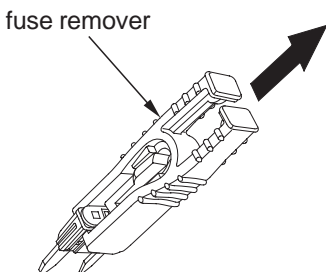

If You Crash

Personal safety is your first priority after a crash. If you or anyone else has been injured, take time to assess the severity of the injuries and whether it is safe to continue riding. Call for emergency assistance if needed. Also follow applicable laws and regulations if another person or vehicle is involved in the crash.

If you decide that you are capable of riding safely, first evaluate the condition of your motorcycle. If the engine is still running, turn it off and look it over carefully; inspect it for fluid leaks, check the tightness of critical nuts and bolts, and secure such parts as the handlebar, control levers, brakes, and wheels. If there is minor damage, or you are unsure about possible damage, ride slowly and cautiously. Sometimes, crash damage is hidden or not immediately apparent, so you should have your motorcycle thoroughly checked at a qualified service facility as soon as possible. Also, be sure to have your Honda dealer check the frame and suspension after any serious crash.

If your motorcycle cannot be ridden, see *Transporting Your Motorcycle*, page 210 .

If You Lose Your Key

You should receive a key number plate with your keys. Store this plate in a safe place.

Be sure to record your key number in the Quick Reference section at the rear of the manual. You'll need this number to have a duplicate key made.

A lost key won't be a problem if you take preventative action. Store one duplicate key in a safe place at home and carry a second duplicate in your wallet.

If you lose your key and aren't carrying a duplicate, either get your spare or have one made. If you don't know your key number, call the dealer where you purchased your Honda. They may have it listed in their records. If they don't, transport your motorcycle to them or the nearest Honda dealer. The dealer will probably have to remove the ignition switch assembly to find the key number so they can make a key for you.

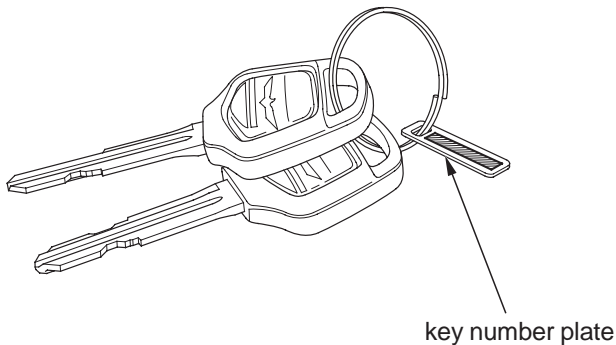

If Your Battery Is Low (or Dead)

Jump starting is not recommended, especially if you use an automobile battery. The greater amperage of an automobile battery when the car engine is running can damage your motorcycle's electrical system.

Bump starting is also not recommended.

If you can't charge the battery or it appears unable to hold a charge, contact your Honda dealer.

Technical Information

This section contains dimensions, capacities, and other technical data, plus information on government requirements and how to break-in your motorcycle.

Vehicle Identification	240
Specifications	242
Break-in Guidelines	248
Tire Pressure Monitoring System (TPMS) Explanation	249
Emission Control Systems	251
Catalytic Converters.....	255
Oxygenated Fuels.....	256

Vehicle Identification

Serial Numbers

The VIN and engine serial number are required when you register your motorcycle. They may also be required when ordering replacement parts. You may record these numbers in the Quick Reference section at the rear of this manual.

The VIN (vehicle identification number) is stamped on the right side of the steering head and also appears on the Safety Certification Label attached to the left side of the steering head.

The engine number is stamped on the right side of the crankcase.

LEFT SIDE

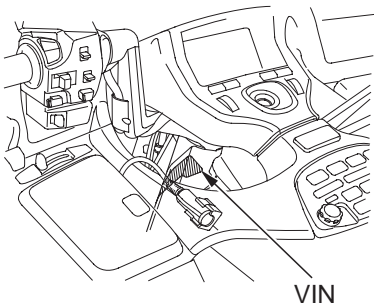

RIGHT SIDE

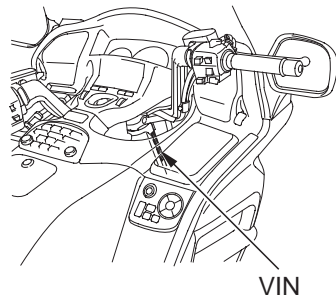

RIGHT SIDE

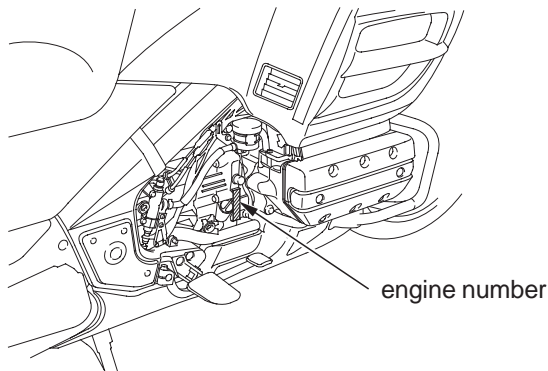

Vehicle Identification

Color Label & Code

The color label is attached inside the fuel filler compartment lid.

The color code is helpful when ordering replacement parts. You may record the color and code in the Quick Reference section at the rear of this manual.

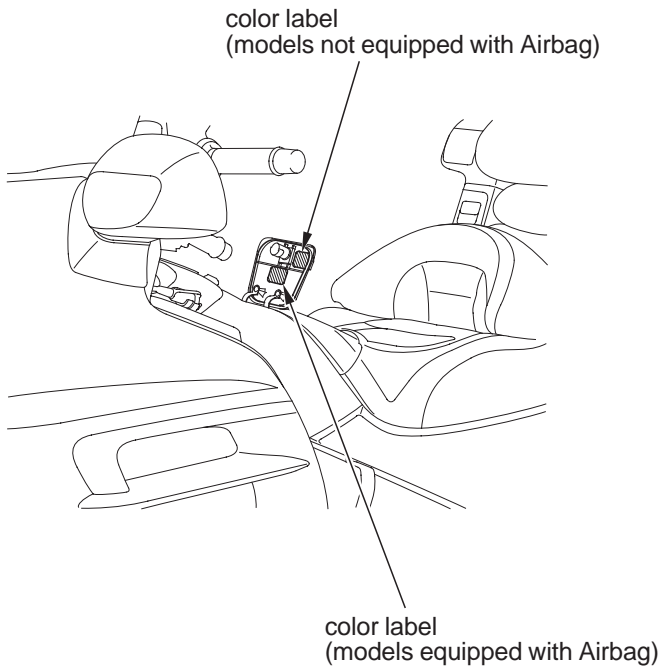

Specifications

Dimensions	
overall length	103.7 in (2,635 mm)
overall width	37.2 in (945 mm)
overall height	57.3 in (1,455 mm)
wheelbase	66.5 in (1,690 mm)
ground clearance	4.9 in (125 mm)

Fuel & Lubricants	
fuel recommendation	unleaded gasoline, pump octane number of 86 or higher
fuel tank capacity	6.6 US gal (25 ℓ)
engine oil capacity	after disassembly: 4.9 US qt (4.6 ℓ) after draining: 3.8 US qt (3.6 ℓ) after draining & oil filter change: 3.9 US qt (3.7 ℓ)
engine oil recommendation	API Service Classification SG or higher except oils labeled as energy conserving on the circular API service label, SAE 10W-30, JASO T 903 standard MA, Pro Honda GN4 4-stroke oil (USA & Canada) or Honda 4-stroke oil (Canada only), or an equivalent motorcycle oil

Specifications

Fuel & Lubricants (Cont'd)	
final drive oil capacity	after draining: 4.1 US oz (120 cm ³)
cooling system, recommendation	Pro Honda HP Coolant or an equivalent high quality ethylene glycol antifreeze containing corrosion protection inhibitors specifically recommended for use in aluminum engines
cooling system, capacity	4.07 US qt (3.85 ℓ)

Capacities	
passenger capacity	Operator and one passenger
maximum weight capacity	410 lbs (186 kg) 419 lbs (190 kg) (Canada only) rider, passenger, all cargo and accessories
cargo capacity	travel trunk: 20.0 lbs (9.0 kg) each saddlebag: 20.0 lbs (9.0 kg) each fairing pocket (Models not equipped with Airbag): 4.5 lbs (2.0 kg) fairing pocket (Models equipped with Airbag): 4.5 lbs (2.0 kg) each trunk side pocket: 1.0 lbs (0.5 kg) total of all cargo: 71 lbs (32 kg)

Specifications

Engine Specifications	
displacement	111.8 cu-in (1,832 cm ³)
bore & stroke	2.91 × 2.80 in (74.0 mm × 71.0 mm)
compression ratio	9.8 : 1
spark plug (standard)	BKR6E-11 (NGK) or K20PR-U11 (DENSO)
spark plug (cold climate)	BKR5E-11 (NGK) or K16PR-U11 (DENSO)
spark plug (high speed riding)	BKR7E-11 (NGK) or K22PR-U11 (DENSO)
valve clearance (cold)	intake 0.006 in (0.15 mm) exhaust 0.009 in (0.22 mm)
spark plug gap	0.039 – 0.043 in (1.00 – 1.10 mm)
idle speed	700 ± 70 rpm (No adjustment)

Power Transmission	
primary reduction	1.591
secondary reduction	1.028
final reduction	2.750
gear ratio, 1st	2.375
2nd	1.454
3rd	1.068
4th	0.843
OD	0.686
final drive	shaft

Specifications

Chassis & Suspension	
caster	29° 15'
trail	4.3 in (109 mm)
tire size, front	130/70R18M/C 63H DUNLOP D250F BRIDGESTONE G709 RADIAL
tire size, rear	180/60R16M/C 74H DUNLOP D250 BRIDGESTONE G704 RADIAL
tire type	radial, tubeless
tire pressure, front (cold)	36 psi (250 kPa , 2.50 kgf/cm ²)
tire pressure, rear (cold)	41 psi (280 kPa , 2.80 kgf/cm ²)

Electrical	
battery	12 V – 20 Ah
generator	1.2 kW/5,000 rpm

Specifications

Lights	
headlight	12 V – 55 W × 2 (high) 12 V – 55 W × 2 (low)
brake/tail light	12 V – 21/5 W × 6
turn signal lights	12 V – 21/5 W × 2 (front) 12 V – 21 W × 2 (rear)
license light	12 V – 5 W
instrument light	LED
neutral indicator	LED
turn signal indicator	LED
high beam indicator	LED
low oil pressure indicator	LED
side stand indicator	LED
low fuel indicator	LED
PGM-FI indicator	LED
reverse indicator	LED
overdrive indicator	LED
CRUISE ON indicator	LED
CRUISE SET indicator	LED
ABS indicator (models equipped with ABS)	LED
AIRBAG indicator (models equipped with Airbag)	LED

Specifications

Fuses	
main A	30 A
main B	120 A
speed limit fuse	60 A
external amplifier fuse (models equipped with Premium Audio)	40 A
other fuses	30 A, 20 A, 15 A, 10 A, 5 A

Torque Specifications	
engine oil drain bolt	25 lbf·ft (34 N·m , 3.5 kgf·m)
engine oil filter	19 lbf·ft (26 N·m , 2.7 kgf·m)
front wheel axle bolt	44 lbf·ft (59 N·m , 6.0 kgf·m)
right front wheel caliper fixing bolts	23 lbf·ft (31 N·m , 3.2 kgf·m)
left front wheel caliper socket bolt	23 lbf·ft (31 N·m , 3.2 kgf·m)
front wheel axle pinch bolts	16 lbf·ft (22 N·m , 2.2 kgf·m)
rear wheel nuts	80 lbf·ft (108 N·m , 11.0 kgf·m)
final drive oil drain bolt	15 lbf·ft (20 N·m , 2.0 kgf·m)

Break-in Guidelines

Help assure your motorcycle's future reliability and performance by paying extra attention to how you ride during the first 300 miles (500 km).

During this period, avoid full-throttle starts and rapid acceleration.

Tire Pressure Monitoring System (TPMS) Explanation

Both tires should be checked monthly when cold, and inflated to the inflation pressure recommended by the vehicle manufacturer on the tire information label.

(If your vehicle has different tires than those indicated on the vehicle tire information label, you should determine the proper tire inflation pressure for those tires.)

As an added safety feature, your vehicle has been equipped with a tire pressure monitoring system (TPMS) that illuminates a **low tire pressure indicator** when one or more of your tires significantly under-inflated.

Accordingly, when the low tire pressure indicator illuminates, you should stop and check your tires as soon as possible, and inflate them to the proper pressure.

Riding on a significantly under-inflated tire causes the tire to overheat and can lead to tire failure. Under-inflation also reduces fuel efficiency and tire tread life, and may affect the vehicle's handling and stopping ability.

Please note that the TPMS is not a substitute for proper tire maintenance, and it is the rider's responsibility to maintain correct tire pressure, even if under-inflation has not reached the level to trigger illumination of the TPMS low tire pressure indicator.



low tire pressure indicator

Tire Pressure Monitoring System (TPMS) Explanation

Your vehicle has also been equipped with a TPMS indicator to indicate when the system is not operating properly. The TPMS indicator displays the symbol “TPMS” when illuminated.

When the TPMS indicator is illuminated, the system may not be able to detect or signal low tire pressure as intended.

TPMS malfunctions may occur for a variety of reasons, including the installation of replacement or alternate tires or wheels on the vehicle that prevent the TPMS from functioning properly.

Always check the TPMS indicator after replacing one or more tires or wheels on your vehicle to ensure that the replacement or alternate tires and wheels allow the TPMS to continue to function properly.

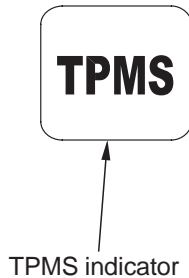

Emission Control Systems

Exhaust Emission Requirements

The U.S. Environmental Protection Agency (EPA), the California Air Resources Board (CARB), and Environment Canada (EC) require that your motorcycle comply with applicable exhaust emissions standards during its useful life, when operated and maintained according to the instructions provided.

Noise Emission Requirements

The EPA also requires that motorcycles built after January 1, 1983 comply with applicable noise emission standards for one year or 3,730 miles (6,000 km) after the time of sale to the ultimate purchaser, when operated and maintained according to the instructions provided.

Warranty Compliance

Compliance with the terms of the Distributor's Warranties for Honda Motorcycle Emission Control Systems is necessary in order to keep the emissions system warranty in effect. (USA only)

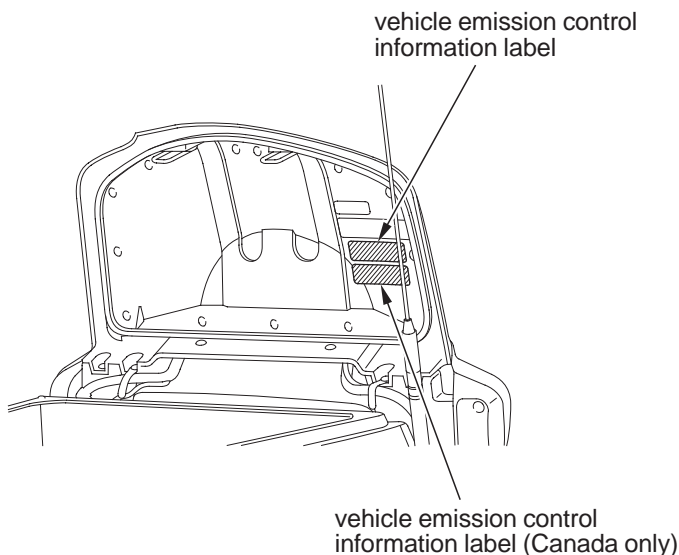

The Vehicle Emission Control Information label is attached inside the trunk lid.

Emission Control Systems

Source of Exhaust Emissions

The combustion process produces carbon monoxide (CO), oxides of nitrogen (NO_x) and hydrocarbons (HC). Control of hydrocarbons and oxides of nitrogen is very important because, under certain conditions, they react to form photochemical smog when subjected to sunlight. Carbon monoxide does not react in the same way, but it is toxic.

Honda Motor Co., Ltd. utilizes various systems to reduce carbon monoxide, oxides of nitrogen and hydrocarbons.

Exhaust Emission Control System

The exhaust emission control system includes a PGM-FI system, two three-way catalytic converters, a secondary air injection system, and two heated oxygen sensors or two air fuel ratio sensors.

No adjustment to these systems should be made although periodic inspection of the components is recommended.

PGM-FI System

The PGM-FI system uses sequential multiport fuel injection. It has four subsystems: Air Intake, Engine Control, Fuel Control, and Exhaust Control. The Engine Control Module (ECM) uses various sensors to determine how much air is going into the engine. It then controls how much fuel to inject under all operating conditions.

Ignition Timing Control System

The system constantly adjusts the ignition timing, reducing the amount of HC, CO and NO_x produced.

Secondary Air Injection System

The secondary air injection system introduces filtered air into the exhaust gases in the exhaust port. The secondary air injection system helps improve emission control performance.

Three-Way Catalytic Converters

The three-way catalytic converters are in the exhaust system. Through chemical reactions, they convert HC, CO, and NO_x in the engine's exhaust to carbon dioxide (CO₂), nitrogen (N), and water vapor.

Emission Control Systems

Evaporative Emission Control System

This motorcycle complies with the requirements of the California Air Resources Board (CARB) evaporative emission regulations. Fuel vapor from the fuel tank is directed into the charcoal canister and air cleaner where it is adsorbed and stored while the engine is stopped. When the engine is running and the purge control solenoid valve is open, fuel vapor in the charcoal canister and air cleaner is drawn into the engine through the throttle body.

Crankcase Emission Control System

The engine is equipped with a closed crankcase system to prevent discharging crankcase emissions into the atmosphere. Blow-by gas is returned to the combustion chamber through the air cleaner and the intake manifold.

Emission Control Systems

Problems That May Affect Motorcycle Exhaust Emissions

If you are aware of any of the following symptoms, have the vehicle inspected and repaired by your authorized Honda motorcycle dealer.

Symptoms:

1. Hard starting or stalling after starting
2. Rough idle
3. Misfiring or backfiring during acceleration
4. After-burning (backfiring)
5. Poor performance (driveability) and poor fuel economy

Noise Emission Control System

TAMPERING WITH THE NOISE CONTROL SYSTEM IS PROHIBITED:

U. S. federal law prohibits, or Canadian provincial laws may prohibit the following acts or the causing thereof: (1) The removal or rendering inoperative by any person, other than for purposes of maintenance, repair or replacement, of any device or element of design incorporated into any new vehicle for the purpose of noise control prior to its sale or delivery to the ultimate purchaser or while it is in use; or (2) the use of the vehicle after such device or element of design has been removed or rendered inoperative by any person.

AMONG THOSE ACTS PRESUMED TO CONSTITUTE TAMPERING ARE THE FOLLOWING ACTS:

1. Removal of, or puncturing the muffler, baffles, header pipes or any other component which conducts exhaust gases.
2. Removal of, or puncturing of any part of the intake system.
3. Lack of proper maintenance.
4. Replacing any moving parts of the vehicle, or parts of the exhaust or intake system, with parts other than those specified by the manufacturer.

Fuel Permeation Emission Control System

This vehicle complies with the Fuel Permeation Emission Control regulations of the U.S. Environmental Protection Agency (EPA), the California Air Resources Board (CARB), and Environment Canada (EC). The fuel tank, fuel hoses, and fuel vapor charge hoses used on this vehicle incorporate fuel permeation control technologies. Tampering with the fuel tank, fuel hoses, or fuel vapor charge hoses to reduce or defeat the effectiveness of the fuel permeation technologies is prohibited by federal regulations.

Catalytic Converters

This motorcycle is equipped with two three-way catalytic converters. Each catalytic converter contains precious metals that serve as catalysts, promoting chemical reactions to convert the exhaust gasses without affecting the metals.

The catalytic converters act on HC, CO, and NOx. Replacement parts must be original Honda parts or equivalents.

The catalytic converters must operate at high temperature for the chemical reactions to take place. They can set fire to any combustible materials that come near them. Park your motorcycle away from high grasses, dry leaves, or other flammables.

Defective catalytic converters contribute to air pollution, and can impair your engine's performance. Follow these guidelines to protect your motorcycle's catalytic converters.

- Always use unleaded gasoline. Even a small amount of leaded gasoline can contaminate the catalyst metals, making the catalytic converters ineffective.
- Keep the engine in good running condition.
A poorly running engine can cause the catalytic converter to overheat causing damage to the converter or the motorcycle.
- If your engine is misfiring, backfiring, stalling, or otherwise not running properly, stop riding and turn off the engine. Have your motorcycle serviced as soon as possible.

Oxygenated Fuels

Some conventional gasolines are being blended with alcohol or an ether compound. These gasolines are collectively referred to as oxygenated fuels. To meet clean air standards, some areas of the United States and Canada use oxygenated fuels to help reduce emissions.

If you use an oxygenated fuel, be sure it is unleaded and meets the minimum octane rating requirement.

Before using an oxygenated fuel, try to confirm the fuel's contents. Some states/provinces require this information to be posted on the pump.

The following are the EPA-approved percentages of oxygenates:

ETHANOL (ethyl or grain alcohol) 10% by Volume

You may use gasoline containing up to 10% ethanol by volume. Gasoline containing ethanol may be marketed under the name "Gasohol".

MTBE (Methyl Tertiary Butyl Ether) 15% by Volume

You may use gasoline containing up to 15% MTBE by volume.

METHANOL (methyl or wood alcohol) 5% by Volume

You may use gasoline containing methanol containing up to 5% methanol by volume as long as it also contains cosolvents and corrosion inhibitors to protect the fuel system. Gasoline containing more than 5% methanol by volume may cause starting and/or performance problems. It may also damage metal, rubber, and plastic parts of your fuel system.

If you notice any undesirable operating symptoms, try another service station or switch to another brand of gasoline.

Fuel system damage or performance problems resulting from the use of an oxygenated fuel containing more than the percentages of oxygenates mentioned above are not covered under warranty.

Oxygenated fuels can damage paint and plastic. Be careful not to spill fuel when filling the fuel tank. Wipe up any spills immediately.

NOTICE

Oxygenated fuels can damage paint and plastic. Damage caused by spilled fuel is not covered by warranty.

Consumer Information

This section contains information on your warranty and how to get an official Honda Service Manual.

Authorized Manuals	258
Warranty Coverage	261
Warranty Service.....	262
Contacting Honda.....	263
Your Honda Dealer	264
The Honda Rider's Club (USA only)	265
Reporting Safety Defects (USA only).....	266

Authorized Manuals

The Service Manual used by your authorized Honda dealer is available from Helm, Inc. (USA only, Canada: See your Honda dealer to order authorized manuals.)

Also available but not necessary to service your model is the Honda Common Service Manual which explains theory of operation and basic service information for various systems common to all Honda motorcycles, motor scooters and ATVs.

These Honda manuals are written for the professional technician, but most mechanically capable owners should find them easy to use if they have the proper tools and observe proper safety standards. Special Honda tools are necessary for some procedures.

Publication Item No.	Description	Price Each*
61MCA55	2010 GL1800 Service Manual/ETM	\$75.00
61CM002	Common Service Manual	\$48.00
31MCA690	2010 GL1800 Owner's Manual	\$16.00
31MCAT40	2010 GL1800 Navigation System Manual	\$16.00

** Prices are subject to change without notice and without incurring obligation.*

(Also available for Models equipped with Airbag)

Publication Item No.	Description	Price Each*
31MCAU40	2010 GL1800 Owner's Manual Airbag Supplement	\$16.00
31MCAV20	2010 GL1800 Airbag Brochure	\$14.00

** Prices are subject to change without notice and without incurring obligation.*

Authorized Manuals

Order On-Line: www.helminc.com

Order Toll Free: **1-888-CYCLE93** (1-888-292-5393)

(NOTE: For Credit Card Orders Only)

Monday — Friday 8:00 AM — 6:00 PM EST

OR

By completing this form you can order the materials desired. You can pay by check or money order, or charge to your credit card. Mail to Helm, Inc. at the address shown on the back of this order form (USA only).

Canada: See your Honda dealer to order authorized manuals.

Publication Item No.	Item Description	Qty.	Price Each*	Total Price
*Prices are subject to change without notice and without incurring obligation. Orders are mailed within 10 days. Please allow adequate time for delivery.		Sub Total		
		Purchaser's Sales Tax Mich. add 6 % Calif. add 7.25 %		
		Handling Charge		\$3.75
		Grand Total		

**S
H
I
P
T
O**

NOTE: Dealers and Companies please provide dealer or company name, and also the name of the person to whose attention the shipment should be sent.

Customer Name _____

Attention _____

Street address/P. O. BOX _____ Apartment Number _____

City _____ State _____ Zip Code _____

Daytime Telephone Number () _____

**P
A
Y
M
E
N
T**

Check or money order enclosed payable to Helm Inc. U.S. funds only. Do not send cash.

Check here if your billing address is different from the shipping address shown above.

MasterCard

VISA

Discover

Account Number

Expiration: Mo. Yr.

-

Security Code

Customer Signature _____ Date _____

These Publications cannot be returned for credit without receiving advance authorization within 14 days of delivery. For returns, a restocking fee may be applied against the original order.

HELM P.O. BOX 07280, DETROIT, MICHIGAN 48207

Warranty Coverage

Your new Honda is covered by these warranties:

- Motorcycle Limited Warranty
- Emission Control System Warranty
- Noise Control Warranty

There are responsibilities, restrictions, and exclusions which apply to these warranties. Please read the Warranties Booklet given to you by your Honda dealer at the time of purchase. Be sure to keep your Honda owner's card with your Warranties Booklet (USA only).

It is important to realize that your warranty applies to defects in material or workmanship of your Honda. Your warranty coverage does not apply to normal wear or deterioration associated with using the motorcycle.

Your warranty coverage will not be voided if you choose to perform your own maintenance. However, you should have the proper tools and service information and be mechanically qualified. Failures that occur due directly to improper maintenance are not covered.

Almost all of your warranty coverage can be extended through the Honda Protection Plan (USA only). For more information, see your Honda dealer.

Warranty Service

Please remember that recommended maintenance interval servicing is not included in your warranty coverage. Additionally, your warranty does not apply to the normal wear of items (such as brakes, tires, etc.).

If you believe you have a problem with your motorcycle, call the service department of your Honda dealer. Make an appointment for an inspection and diagnosis. Remember, as the owner of the motorcycle, you will be asked to authorize that inspection. Your dealer will give you the results of the inspection. If the problem is covered under warranty, your dealer will perform the warranty repairs for you.

If you have questions about warranty coverage or the nature of the repair, it is best to talk to the Service Manager of your Honda dealer.

Sometimes, in spite of the best intentions of all concerned, a misunderstanding may occur. If you aren't satisfied with your dealer's handling of the situation, we suggest you discuss your problem with the appropriate member of the dealership's management team. If the problem has already been reviewed with the Service Manager, Parts Manager, Sales Manager, etc., contact the Owner of the dealership or their designated representative.

Contacting Honda

Your owner's manual was written to cover most of the questions you might ask about your Honda. Any questions not answered in the owner's manual can be answered by your Honda dealer. If your dealer doesn't have the answer right away, they will get it for you.

If you have a difference of opinion with your dealer, please remember that each dealership is independently owned and operated. That's why it's important to work to resolve any differences at the dealership level.

If you wish to comment on your experiences with your Honda or with your dealer, please send your comments to the following address (USA only):

Motorcycle Division, American Honda Motor Co., Inc., P.O. Box 2200,
Torrance, CA 90509-2200, Mailstop: 100-4C-7B, Telephone: (866) 784-1870.

Canada: Refer to the Warranties Booklet that was supplied with your vehicle.

Please include the following information in your letter:

- name, address, and telephone number
- product model, year, and VIN
- date of purchase
- dealer name and address

We will likely ask your Honda dealer to respond, or possibly acknowledge your comments directly.

Your Honda Dealer

Once you purchase your new Honda, get familiar with the organization of your Honda dealer so you can utilize the full range of services available.

The service department is there to perform regular maintenance and unexpected repairs. It has the latest available service information from Honda. The service department will also handle warranty inspections and repairs.

The parts department offers Honda Genuine Parts, Pro Honda products, Honda Genuine Accessories (USA only), and Honda accessories and products (Canada only). The same quality that went into your Honda can be found in Honda Genuine replacement parts. You'll also find comparable quality in the accessories and products available from the parts department.

The sales department offers the Honda Protection Plan to extend almost all of your warranty coverage (USA only).

Your Honda dealer can inform you about competition and other riding events in your area. You'll also find that your dealer is a source of information about safety training available in your local area and the Honda Rider's Club of America (USA only).

We're sure you'll be as pleased with the service your Honda dealer continues to provide after the sale as you are with the quality and dependability of your Honda.

The Honda Rider's Club (USA only)

You may be eligible for a Honda Rider's Club of America (HRCA) membership with the purchase of your new Honda. You can log on to the HRCA Clubhouse website for details at www.hrca.honda.com.

Reporting Safety Defects (USA only)

If you believe that your vehicle has a defect which could cause a crash or could cause injury or death, you should immediately inform the National Highway Traffic Safety Administration (NHTSA) in addition to notifying American Honda Motor Co., Inc.

If NHTSA receives similar complaints, it may open an investigation, and if it finds that a safety defect exists in a group of vehicles, it may order a recall and remedy campaign. However, NHTSA cannot become involved in individual problems between you, your dealer, or American Honda Motor Co., Inc.

To contact NHTSA, you may call the Vehicle Safety Hotline toll-free at 1-888-327-4236 (TTY: 1-800-424-9153); go to <http://www.safercar.gov>; or write to: Administrator, NHTSA, 1200 New Jersey Avenue, SE., Washington, DC 20590.

You can also obtain other information about motor vehicle safety from <http://www.safercar.gov>.

Table of Contents

The following presents the contents of each section of your owner's manual.

MOTORCYCLE SAFETY	1
Important Safety Information	2
Accessories & Modifications	4
Safety Labels	6
INSTRUMENTS & CONTROLS	11
Operation Component Locations	12
Gauges & Indicators	16
Multi Information Display	22
Opening/Ending Ceremony	23
On/Off-Opening/Ending Ceremony	24
Special Message for Opening/Ending Ceremony	25
Odometer/Tripmeter	27
Switch the Day Mode Display and Night Mode Display	28
Display Illumination Adjustment	29
Digital Clock	31
Air Temperature Meter	32
Travel Trunk & Saddlebags Open Indicator	33
Display Type Selection	34
Changing the Information Display	35
Controls & Features	37
Ignition Switch	37
Engine Stop Switch	38
Start/Reverse Button	39
Reverse (RVS) Switch	39
Cruise Control Switches	39
Headlight Dimmer Switch	40
Turn Signal Switch	40
Horn Button	40
Audio Control Switches	40
Hazard Switch	41
Headlight Beam Adjustment Knob	42
Rear Suspension Spring Pre-load Adjustment Switch	42
Ventilation Controls	42
Windscreen Height Adjustment	42

Table of Contents

BEFORE RIDING.....	43
Are You Ready to Ride?	44
Protective Apparel.....	44
Rider Training	46
Is Your Motorcycle Ready to Ride?	47
Pre-ride Inspection	47
Load Limits & Guidelines.....	49
Loading.....	49
Load Limits	50
Loading Guidelines	51
Cargo Compartment	52
Travel Trunk & Saddlebags.....	52
Remote Transmitter.....	56
Fairing Pockets	60
Trunk Side Pockets	61
Comfort & Convenience Adjustment.....	62
Windscreen Height Adjustment.....	63
Windscreen Ventilation Louver.....	64
Side Ventilation Louvers	65
Foot Warmer Ventilation Louvers.....	66
Handgrip Heater	67
Seat Heater	68
Accessories	69
Accessory (ACC) Terminal	69

Table of Contents

BASIC OPERATION & RIDING.....	71
Safe Riding Precautions.....	72
Starting & Stopping the Engine.....	73
Preparation.....	73
Starting Procedure.....	74
Flooded Engine.....	74
Bank Angle Sensor Ignition Cut-off System.....	75
How to Stop the Engine.....	75
Shifting Gears.....	76
While You Are Riding.....	77
Riding in Reverse.....	78
Braking.....	80
Anti-Lock Brake System (ABS).....	82
ABS Indicator Light.....	83
Tire Pressure Monitoring System (TPMS).....	85
Low Tire Pressure Indicator.....	86
Tire Pressure Monitoring System (TPMS) Indicator.....	87
Changing a Tire with TPMS.....	88
Parking.....	89
Theft-prevention Tips.....	91
Riding with a Passenger or Cargo.....	92
Riding with Cruise Control.....	93
Cruise Control.....	93
To Set Cruise Control.....	94
To Change the Set Speed.....	94
To Cancel Cruise Control.....	95
Riding in Bad Weather.....	96
AUDIO SYSTEMS.....	97
Audio Systems.....	99
MODE Knob/Button Function.....	99
VOLUME Knob/Button Function.....	100
Display Locations.....	101
Controls Locations.....	103
Audio Component Locations.....	105
System Control.....	106

Table of Contents

Switch Output.....	107
VOLUME Control	108
Tone Control	109
Fader Control.....	111
Ambience (AMB)	112
Beep Set.....	113
Auto Volume Control (AVC)	114
Muting	115
AM/FM Radio	116
Radio Antenna.....	116
Select Band.....	117
Select Station.....	118
Preset Stations	119
Auto Select	120
XM Radio (USA only).....	121
Receiving Satellite Radio Service	121
Operating the XM Radio.....	124
XM Radio Display Messages	124
Select Channel.....	125
Preset Channel.....	126
Weather Information.....	127
Weather Band (WB)	127
Auxiliary Function	129
Auxiliary (AUX) Input	129
Input Jack Setup	130
Intercom (I-COM) System.....	132
System Control.....	132
VOLUME Control	133
Intercom Muting.....	134
Navigation System	135
System Control.....	135
Switch Output.....	135
Navi Volume Control.....	136

SERVICING YOUR HONDA	137
<i>Before You Service Your Honda</i>	
The Importance of Maintenance	140
Maintenance Safety	141
Important Safety Precautions	142
Periodic Maintenance	143
Maintenance Schedule	144
Maintenance Record	148
 <i>Service Preparations</i>	
Maintenance Component Locations	149
Tool Kit	152
Owner's Manual Storage	153
Cover Removal	154
Clip Removal	159
 <i>Service Procedures</i>	
<u>Fluids & Filters</u>	
Fuel	160
Engine Oil & Filter	163
Coolant	170
Crankcase Breather	173
Final Drive Oil	174
 <u>Engine</u>	
Clutch System	176
Spark Plugs	178
 <u>Chassis</u>	
Suspension	180
Brakes	184
Tires	189
Side Stand	196
 <u>Electrical</u>	
Battery	197
 Appearance Care	 201

Table of Contents

TIPS	207
Storing Your Honda	208
Transporting Your Motorcycle	210
You & the Environment	211
TAKING CARE OF THE UNEXPECTED.....	213
General Guidelines.....	214
If Your Engine Quits or Won't Start.....	215
If You Have a Flat Tire.....	218
If Your Engine Overheats.....	229
If the Low Oil Pressure Indicator Lights.....	231
If a Fuse Blows.....	232
If You Crash.....	235
If You Lose Your Key.....	236
If Your Battery Is Low (or Dead).....	237
TECHNICAL INFORMATION	239
Vehicle Identification	240
Specifications	242
Break-in Guidelines	248
Tire Pressure Monitoring System (TPMS) Explanation	249
Emission Control Systems	251
Catalytic Converters.....	255
Oxygenated Fuels.....	256
CONSUMER INFORMATION	257
Authorized Manuals	258
Warranty Coverage	261
Warranty Service.....	262
Contacting Honda.....	263
Your Honda Dealer	264
The Honda Rider's Club (USA only).....	265
Reporting Safety Defects (USA only).....	266

Table of Contents

TABLE OF CONTENTS	268
INDEX	276
QUICK REFERENCE	

Index

A

ABS indicator light.....	20, 83
accessories	4
accessory (ACC) terminal	69
air pressure, tires.....	190
air temperature meter	32
American Honda, contacting	263
antenna, radio	116
Anti-Lock Brake System (ABS)	82
apparel, protective	44
appearance care	201
audio systems.....	97
authorized manuals.....	258

B

battery	197
brakes,	
fluid.....	185
pad wear.....	187
braking	80
break-in guidelines	248

C

capacity, fuel	161
care, appearance	201
catalytic converters.....	255
cleaning, appearance care	201
clutch system	176
color label	241
comfort and convenience adjustment	62
compartment,	
owner's manual	153
tool kit.....	152

Index

consumer information	257
controls & features	37
coolant.....	170
coolant temperature gauge	16, 21
crankcase breather	173
cruise control	93
customer service	263

D

defects, reporting safety	266
digital clock adjustment	31
drive, final	174

E

emission control systems.....	251
engine,	
flooded.....	74
low oil pressure	231
number	240
oil	163
overheats.....	229
pinging	160
starting	73
stop switch.....	38
stopping	75
won't start.....	215
environment.....	211

F

fairing pockets	60
final drive oil	174
flat tire	218
flooded engine	74

(cont'd)

Index

fuel,	
gauge.....	16, 21
oxygenated.....	256
recommendation.....	160
tank capacity.....	161
fuses.....	232

G

gasohol.....	256
gasoline.....	160
gauges & indicators.....	16

H

hazard switch.....	41
headlight beam adjustment.....	42
headlight dimmer switch.....	40
heater,	
handgrip.....	67
seat.....	68
helmet holder.....	90
high beam indicator.....	16, 20
Honda,	
contacting.....	263
dealer.....	264
Rider's Club.....	265
Honda Service Manual.....	258
horn button.....	40

I

identification, vehicle.....	240
ignition cut-off system,	
bank angle sensor.....	75
side stand.....	73
ignition switch.....	37
indicators.....	16
inspection, pre-ride.....	47

K

key, lost.....	236
kit, tool.....	152

L

labels, safety	6
lamp check.....	17
limit, weight.....	50
load limits	50
loading guidelines.....	51
lock, steering.....	89
low tire pressure indicator	86

M

maintenance,	
component locations.....	149
importance	140
periodic	143
record	148
safety.....	141
schedule	144
manual, authorized	258
manual, service	258
maximum weight limit	50
modifications	5
multi information display.....	22

N

numbers, serial.....	240
----------------------	-----

Index

O

odometer	27
oil,	
engine.....	163
final drive	174
low pressure.....	231
operation component locations	12
overdrive indicator	16, 18
overheat, engine.....	229
owner's manual storage.....	153
oxygenated fuels.....	256

P

parking	89
pinging, engine	160
plugs, spark	178
pockets,	
fairing	60
trunk side	61
pre-load, rear suspension spring.....	181
pre-ride inspection.....	47
problems, unexpected.....	213
protective apparel	44

R

radio antenna	116
radio,	
AM/FM.....	116
XM.....	121
remote transmitter.....	56
removal,	
clip	159
cylinder head side cover.....	157
engine side cover	156
front lower cover	158
side cover.....	155

Index

reverse,	
button	37
riding in.....	78
system indicator.....	16, 18
reporting safety defects	266
rider training	2, 46
Rider's Club, Honda.....	265
riding,	
bad weather.....	96
basic operation.....	71
clothing.....	44
safety.....	2
safety precautions.....	72
with cruise control.....	93
with passenger or cargo.....	92

S

saddlebag	52
safety,	
important precautions.....	142
labels.....	6
reporting defects.....	266
riding precautions.....	72
schedule, maintenance.....	144
serial numbers.....	240
service,	
customer.....	263
manuals.....	258
warranty.....	262
shifting gears	76
side stand	196
side stand ignition cut-off system.....	73
side stand indicator.....	16, 20
spark knock.....	160
spark plugs.....	178
specifications.....	242

(cont'd)

Index

speedometer.....	16, 17
stand, side.....	196
start/reverse button.....	39
starting,	
engine.....	74
troubleshooting.....	215
steering lock.....	89
stop switch, engine.....	38
stopping engine.....	75
storage,	
motorcycle.....	208
owner's manual.....	153
suspension,	
rear spring pre-load.....	181
switch,	
audio control.....	40, 103
cruise control.....	39, 94
engine stop.....	38
hazard.....	41
headlight dimmer.....	40
ignition.....	36
rear suspension spring pre-load adjustment.....	42, 181
reverse.....	39, 78
turn signal.....	40

T

tachometer.....	16, 17
theft-prevention tips.....	91
tires,	
air pressure.....	190
flat.....	218
replacing.....	194
tire pressure monitoring system (TPMS).....	85
tire pressure monitoring system (TPMS) explanation.....	249
tire pressure monitoring system (TPMS) indicator.....	87
tool kit.....	152
training, rider.....	2, 46
transporting your motorcycle.....	210

Index

travel trunk.....	52
tripmeter.....	27
trouble, unexpected	213
troubleshooting, starting.....	215
trunk side pockets.....	61
trunk, travel.....	52
turn signal indicators	16, 18

V

vehicle identification no. (VIN).....	240
ventilation.....	64, 65, 66

W

warranty,	
coverage.....	261
extended.....	261
service.....	262
washing your motorcycle	202
weight limit.....	50
wheels,	
front removal.....	220
rear removal.....	226
windscreen height adjustment levers	63

Quick Reference

The following is a brief, but important collection of information you need to know about your Honda. You'll also find space to record important notes.

The engine of your Honda can be the most expensive component to repair. Proper maintenance, especially the use of the recommended fluids and filters, prevents premature wear and damage.

Frequent causes of costly repairs are:

Engine oil — insufficient quantity, improper oil.

Air cleaner — dirty, leaking because of improper installation (poor seal).

Record important information on the following page:

VIN	
Engine No.	
Ignition Key No.	
Color Label	
Owner's Name	
Address	
City/State	
Phone	
Dealer's Name	
Address	
City/State	
Phone	
Service Mgr.	

Quick Reference









Scheduled Maintenance	Regular: every 4,000 miles (6,400 km)
Pre-ride Inspection	Check the following items each time before you ride (page 47): tires & wheels, leaks, loose parts, lights, throttle, brakes, indicators, gauges.
Periodic Checks	Check the following items monthly (page 143): tires & wheels, fluids, lights, fuses, nuts & bolts.
Fuel/Capacity	unleaded gasoline, pump octane number 86 or higher 6.6 US gal (25 l)
Engine Oil	API Service Classification SG or higher except oils labeled as energy conserving on the circular API service label, SAE 10W-30, JASO T 903 standard MA, Pro Honda GN4 4-stroke oil or equivalent
Maximum Weight Capacity	410 lbs (186 kg) 419 lbs (190 kg) (Canada only) rider, passenger, all cargo and accessories maximum of all cargo: 71 lbs (32 kg)
Tires	front: 130/70R18M/C 63H DUNLOP D250F BRIDGESTONE G709 RADIAL rear: 180/60R16M/C 74H DUNLOP D250 BRIDGESTONE G704 RADIAL type: radial, tubeless
Tire Pressure (cold)	front: 36 psi (250 kPa , 2.50 kgf/cm ²) rear: 41 psi (280 kPa , 2.80 kgf/cm ²)

Quick Reference

Spark Plugs	standard: BKR6E-11 (NGK) or K20PR-U11 (DENSO) cold climat (below 5°C, 41°F): BKR5E-11 (NGK) or K16PR-U11 (DENSO) high speed riding: BKR7E-11 (NGK) or K22PR-U11 (DENSO)
Coolant	ethylene glycol antifreeze (silicate-free) for aluminum engines in 50/50 solution with Pro Honda HP Coolant or an equivalent distilled water
Fuses	main A: 30 A main B: 120 A speed limiter: 60 A external amplifier (models equipped with Premium Audio): 40 A other: 30 A, 20 A, 15 A, 10 A, 5 A
Final Drive Oil	Hypoid Gear Oil SAE 80

Quick Reference

These symbols are used in Controls & Features section:

SYMBOL	COMPONENT	SEE PAGE
	RUN – engine stop switch	38
	OFF – engine stop switch	38
	START/REVERSE button	39
	HI – headlight dimmer switch	40
	LO – headlight dimmer switch	40
	turn signal switch	40
	horn button	40
	hazard switch	41