



INSTALLATION INSTRUCTIONS

Accessory
LED BRAKE LIGHT
 P/N 08U76-MKC-A00

Application
GL1800/D/DA
GL1800B/BD

Publication No.
MII 16426
 Issue Date
REVISED
April 2018

Honda Dealer: Please give a copy of these instructions to your customer.

PARTS LIST

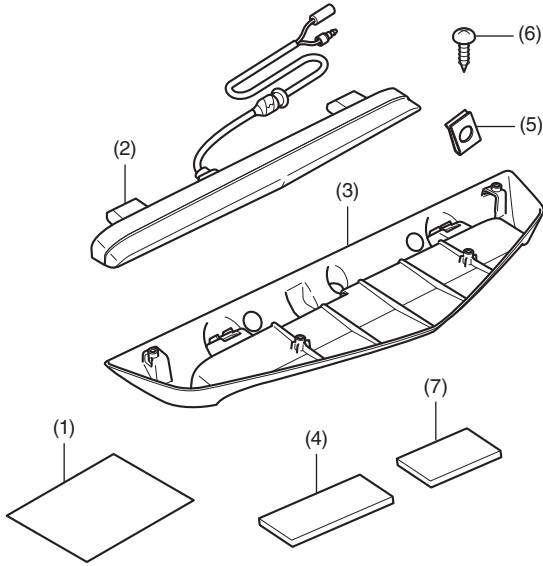

No.	Description	Qty
(1)	Installation Instructions URL	1
(2)	LED brake light	1
(3)	High mount LED brake light base	1
(4)	Cushion tape	1
(5)	Spring nut	2
(6)	5 mm screw	6
(7)	Cushion	2

CHROME TRUNK RACK

Sold separately

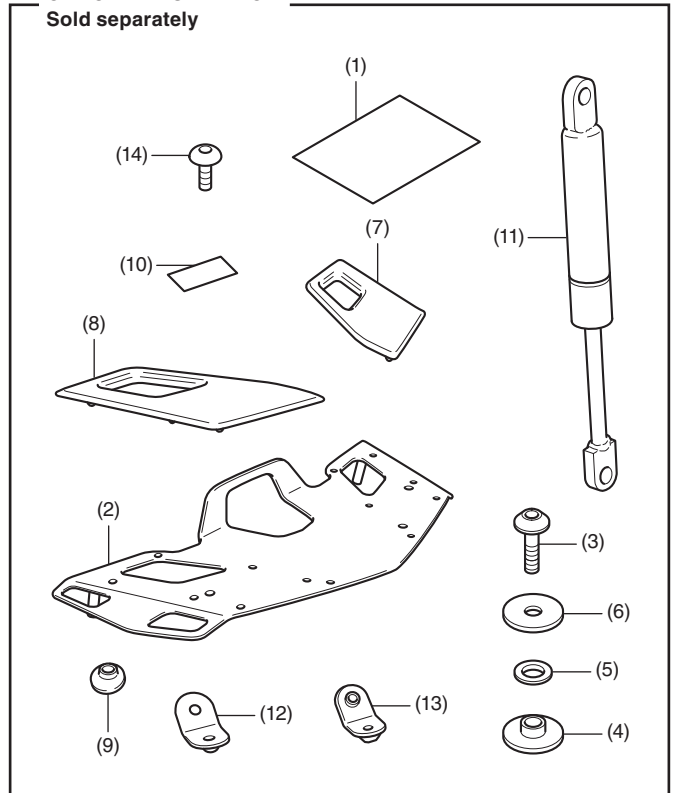

No.	Description	Qty
(1)	Installation Instructions URL	1
(2)	Trunk rack	1
(3)	6 mm bolt	4
(4)	Collar	2
(5)	Rubber washer	4
(6)	Washer	2
(7)	Right rack top cover	1
(8)	Left rack top cover	1
(9)	Grommet	4
(10)	Label	1
(11)	Damper	2
(12)	Lower plate	2
(13)	Upper plate	2
(14)	6 mm screw	2

TRUNK SUB HARNESS

Sold separately

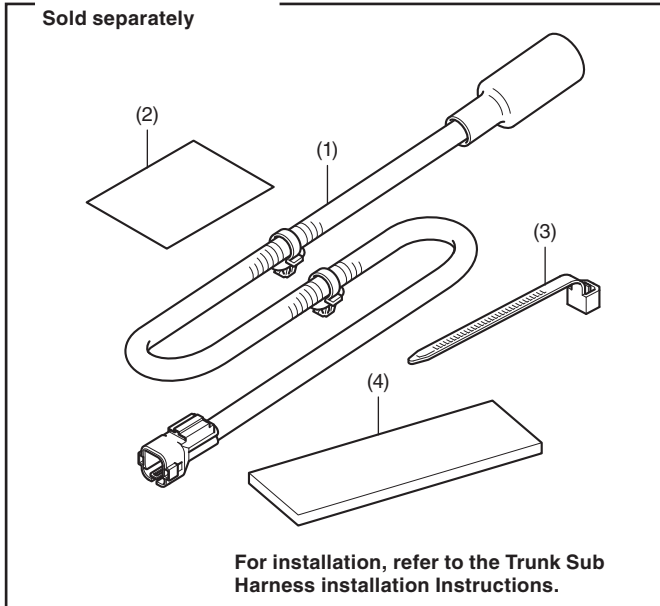

No.	Description	Qty
(1)	Trunk sub harness	1
(2)	Installation Instructions URL	1
(3)	Wire tie	1
(4)	Cushion	2

TOOLS AND SUPPLIES REQUIRED

Hex wrench (5 mm)

Phillips screwdriver

Electric drill

Drill bit (10 mm)

Hole saw (19 mm)

Ruler

Masking tape

Isopropyl alcohol

Dish soap solution

(Water : Dish soap / 100 : 1)

Shop towel

Torque wrench

TORQUE CHART

Tighten all screws, bolts, and nuts to their specified torque values. Refer to the Service Manual for the torque values of the removed parts.

Item	N·m	kgf·m	lbf·ft
5 mm screw	4.2	0.4	3.1
6 mm screw	9	0.9	6.6
6 mm bolt	10	1.0	7

INSTALLATION

▲ CAUTION

- To prevent burns, allow the engine, exhaust system, radiator, etc., to cool before installing the accessory.

NOTE:

- Heat the bonding surfaces with a hair dryer if the ambient air temperature is below 70°F (21°C).
- The adhesive reaches full strength in 72 hours. Wait at least 24 hours before riding your motorcycle.
- Disconnect the negative (-) cable from the battery before installing this accessory.
- The clock memory will be erased when you disconnect the battery. Reset the memories after reconnecting the battery.
- Reinstall the removed parts on the motorcycle and make sure that the wires and harnesses are not pinched.

- Perform step 1 to 18 on the trunk sub harness (sold separately) installation instructions.
- Remove the clip as shown.

<Left side>

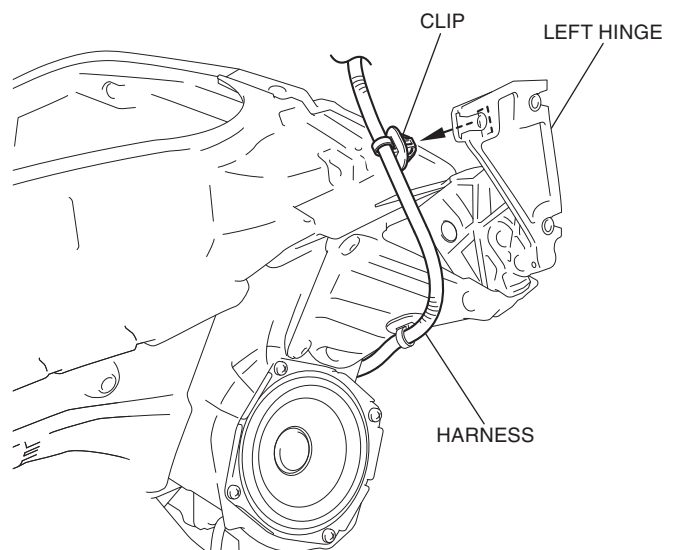

3. Remove the hinge rubber as shown.

- Repeat on the left side.

<Right side>

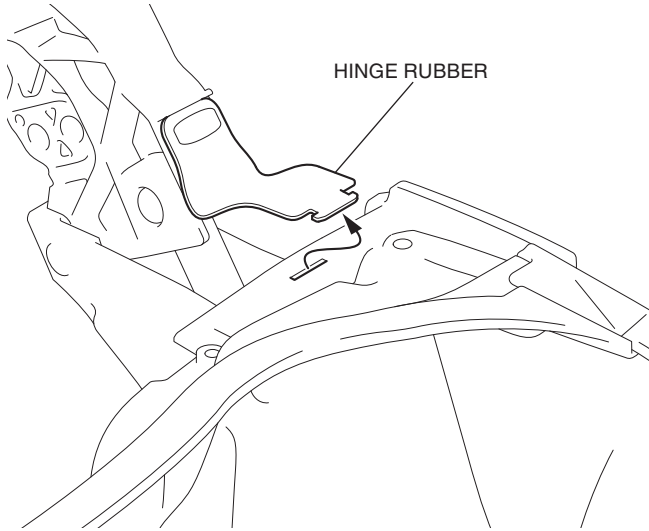

4. Remove the right trunk hinge as shown.

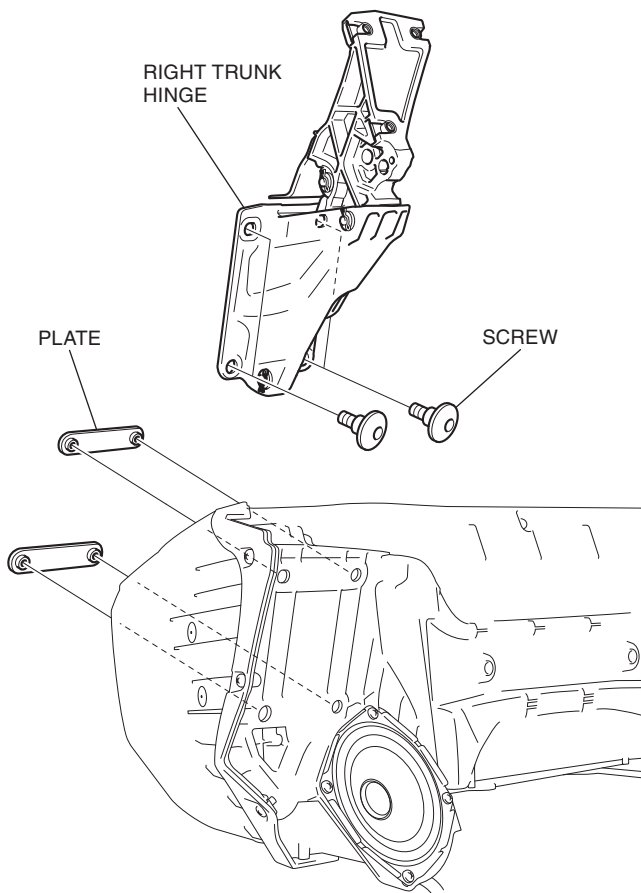

5. Remove the right hinge as shown.

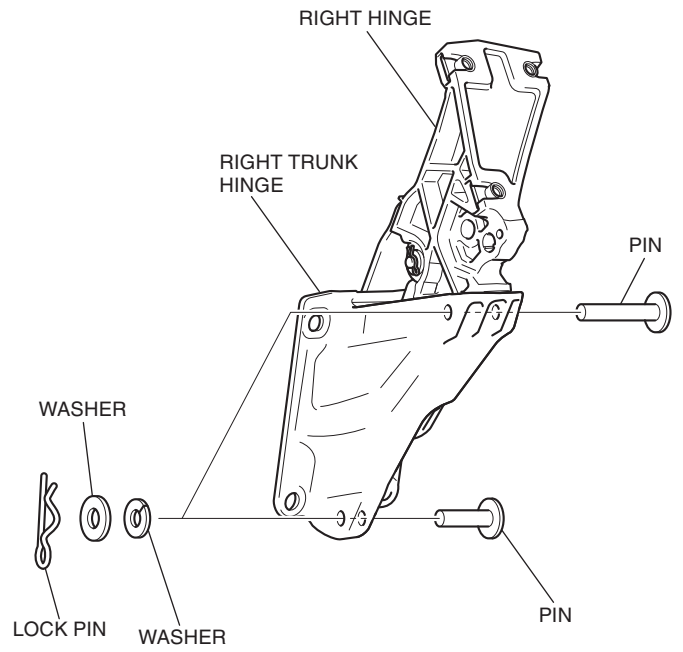

6. Remove the damper as shown.

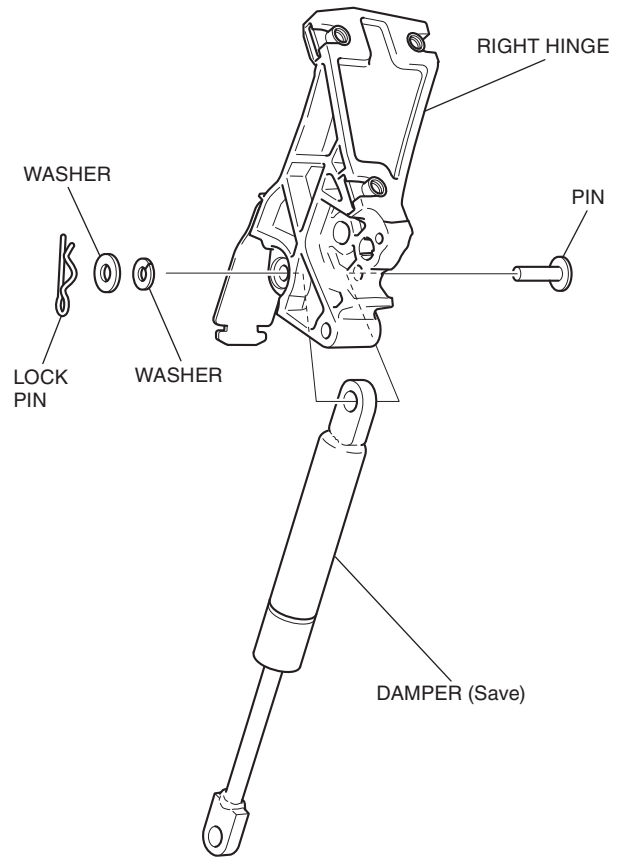

7. Remove the left trunk hinge, left hinge and damper in the same manner as the right side.

8. Remove the clip as shown.

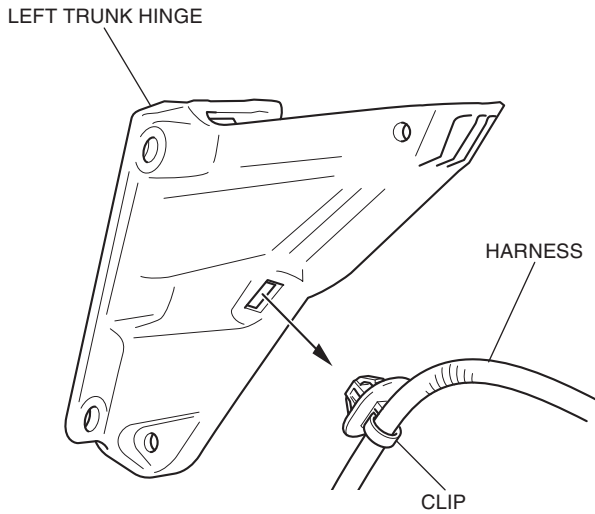

9. Install the accessory damper as shown.

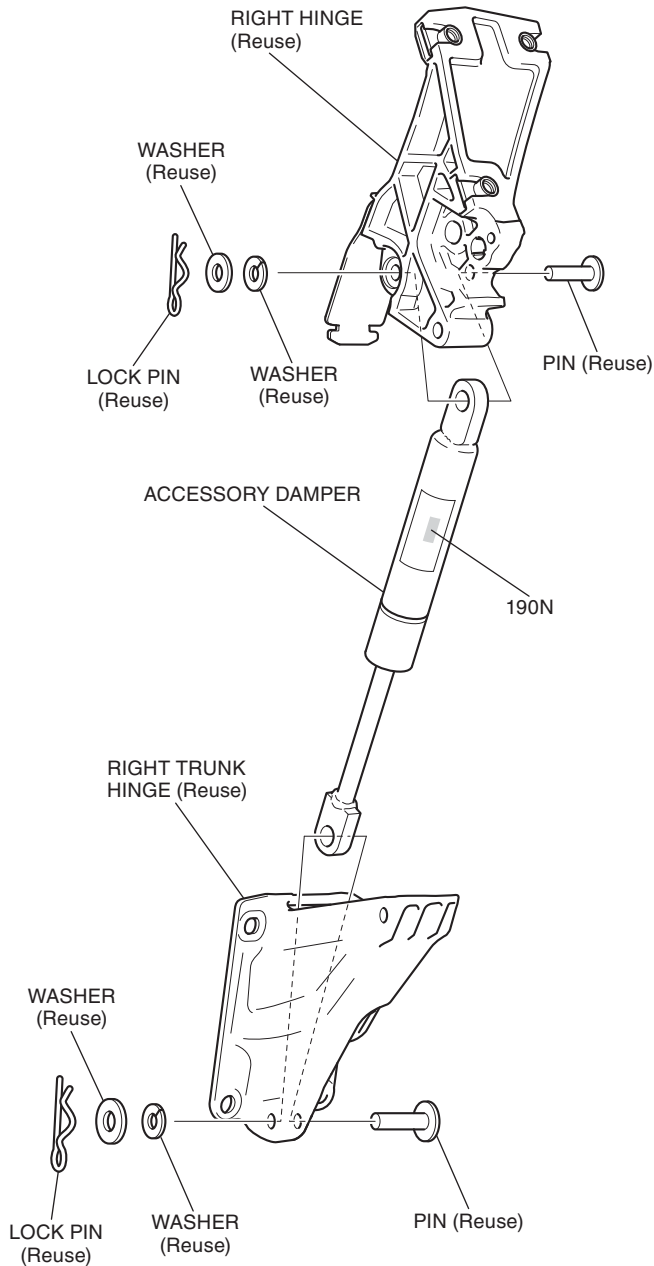

10. Install the right hinge as shown.

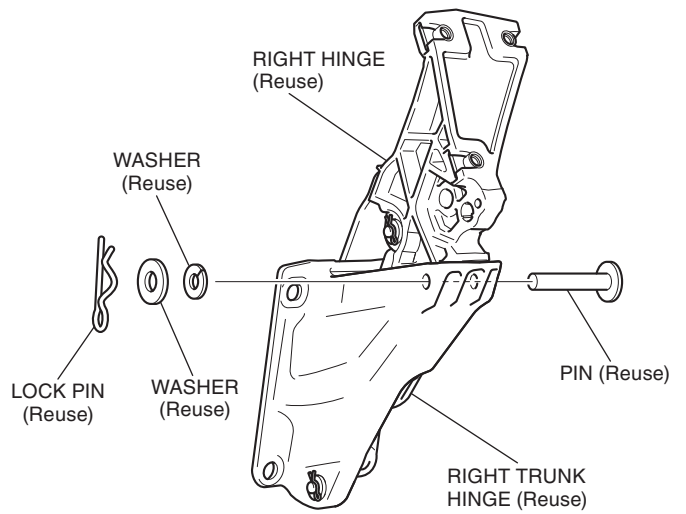

11. Install the accessory damper and left hinge in the same manner as the right side.
12. Install the right and left trunk hinge and hinge rubber in the reverse order of removal.
13. Install the harness in the reverse order of removal.
14. Drill at the marked points of the inner trunk lid as shown.

- Remove any burrs from the edge of the hole.

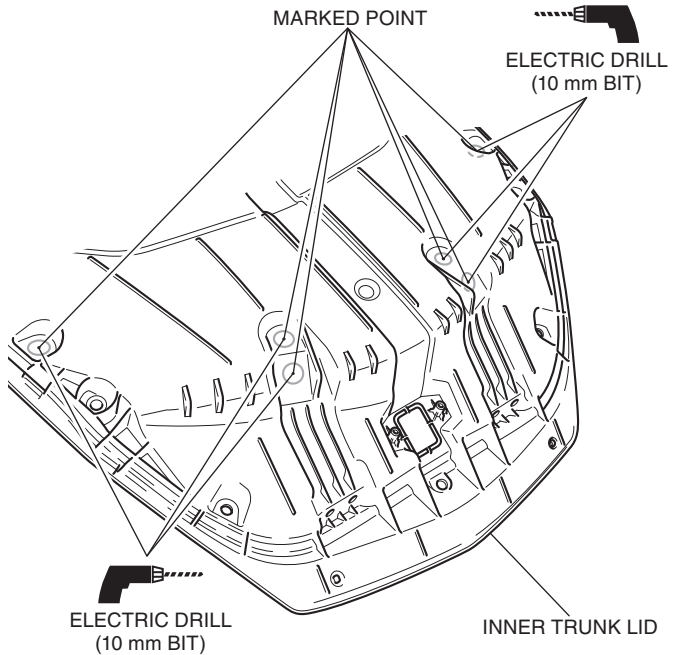

15. Drill 19 mm holes at the marked points of the trunk lid as shown.

- Remove any burrs from the edge of the hole.

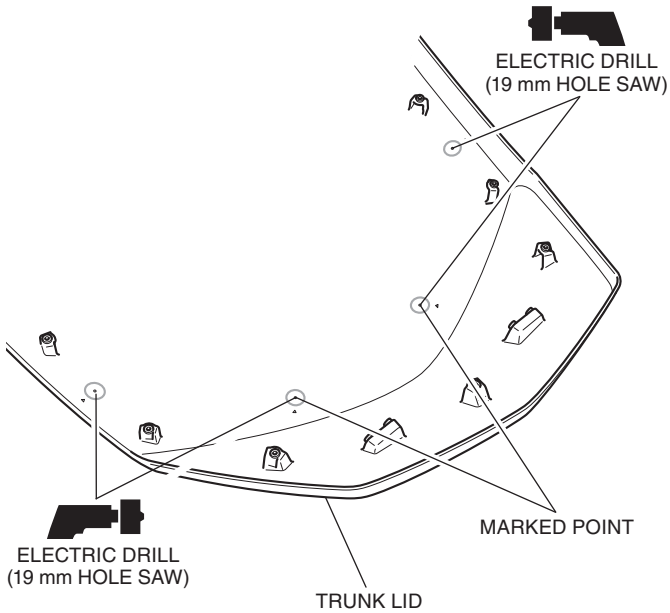

16. Drill a 10 mm hole the marked point of the trunk lid as shown.

- Remove any burrs from the edge of the hole.

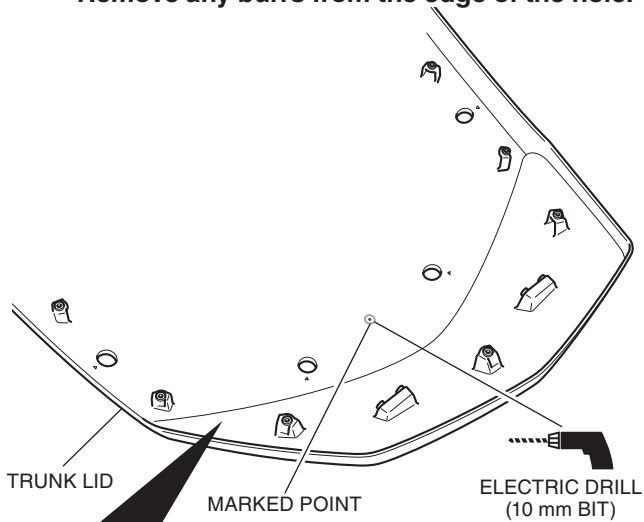

If there is no mark on the trunk lid, mark and then drill at the indicated position.

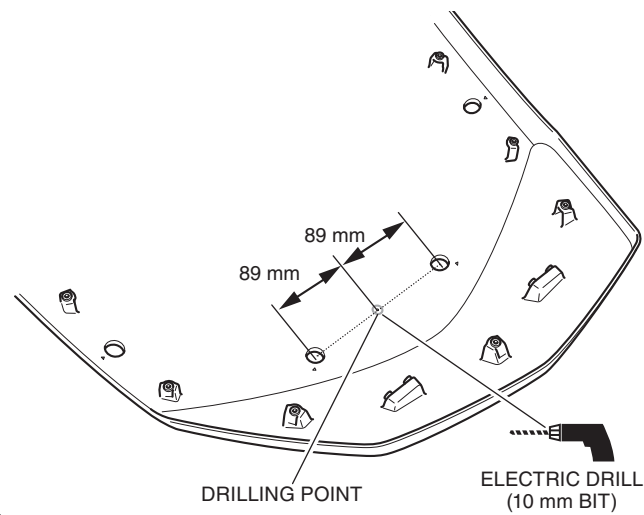

17. Install the grommets as shown.

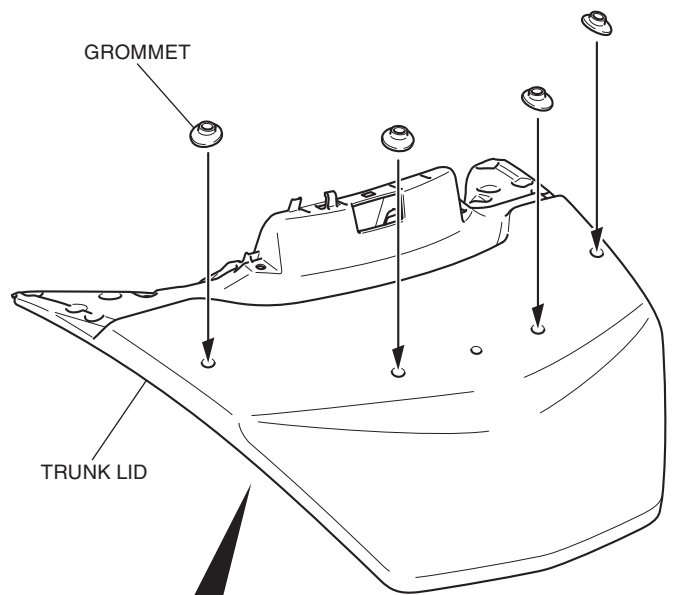

Align the projection of the grommet with the mark of the trunk lid.
<Back side>

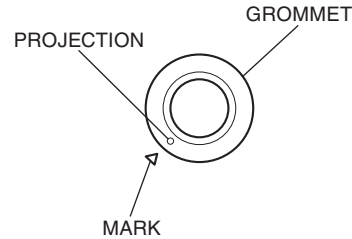

18. Attach the label as shown.

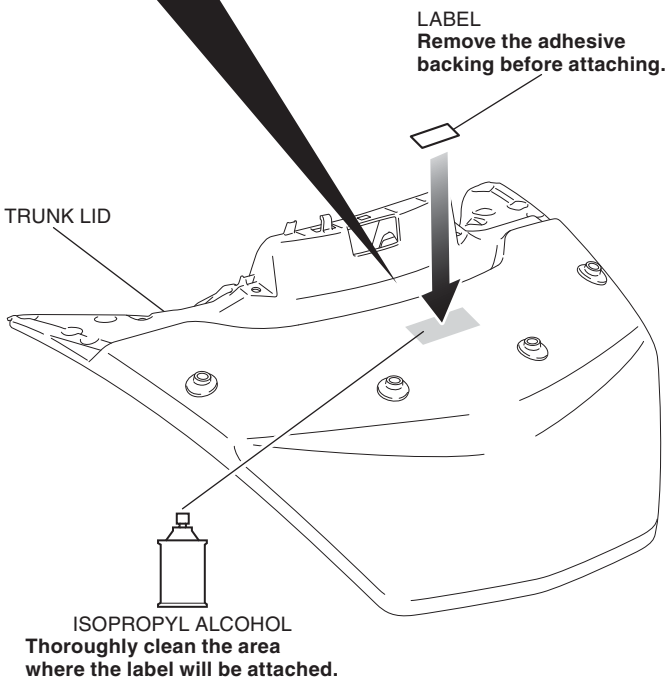
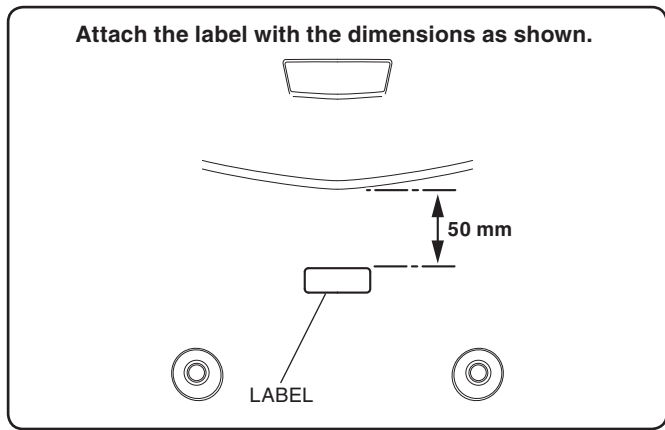

19. Place the rubber washers as shown.

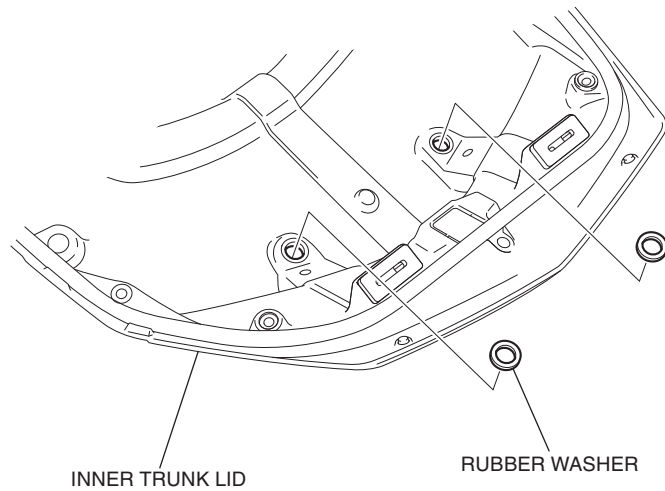

20. Install the lower plate and upper plate as shown.

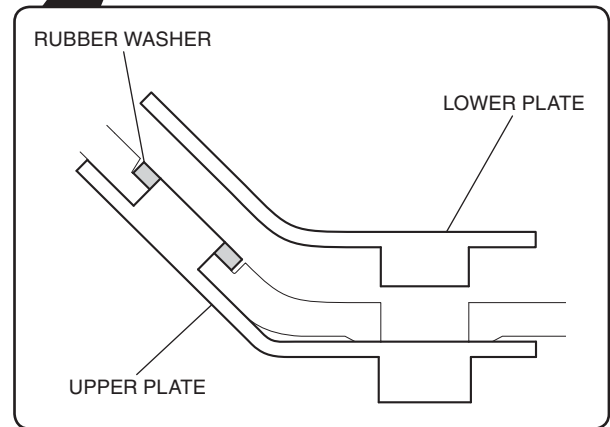
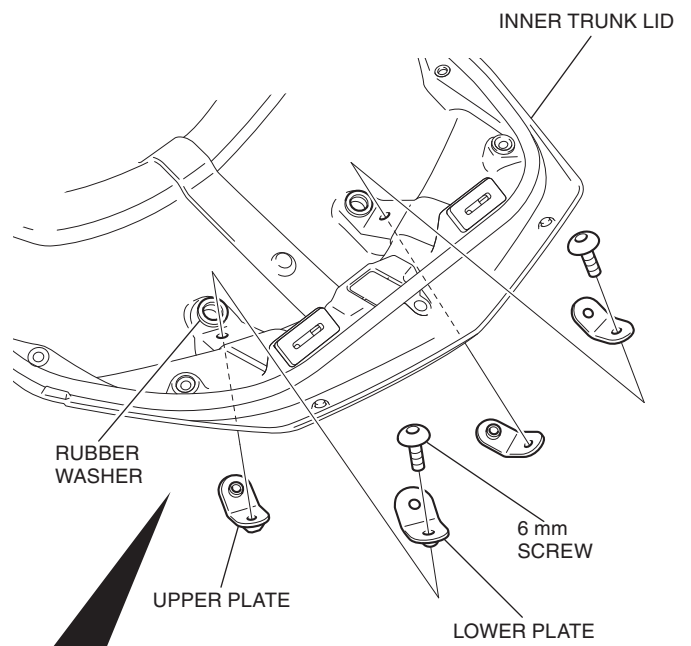

21. Install the collars as shown.

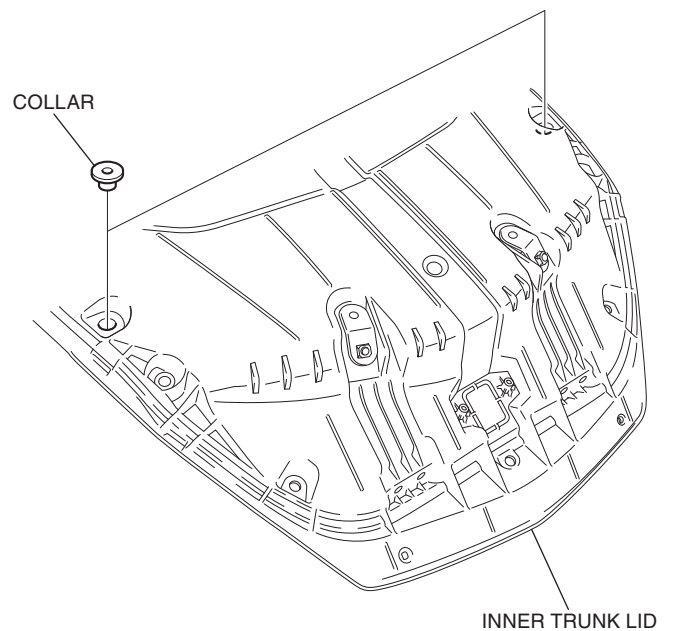

22. Clean the surface of the area shown using isopropyl alcohol.

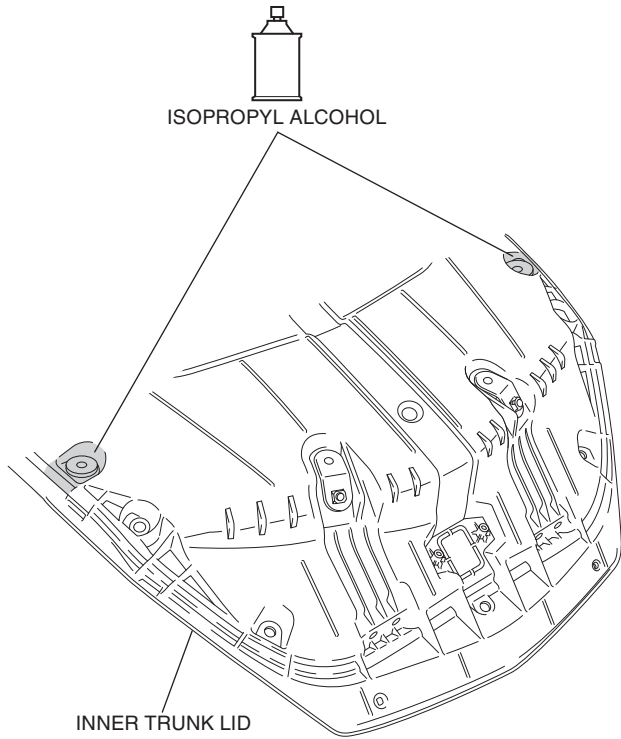

23. Attach the masking tape as shown.

- Repeat on the right side.

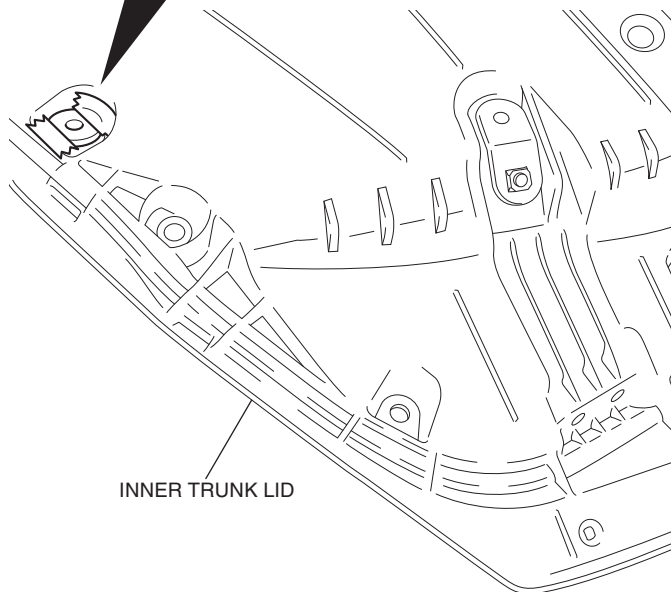
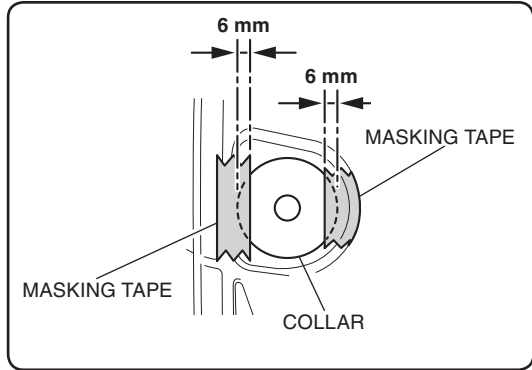

24. Install the spring nuts as shown.

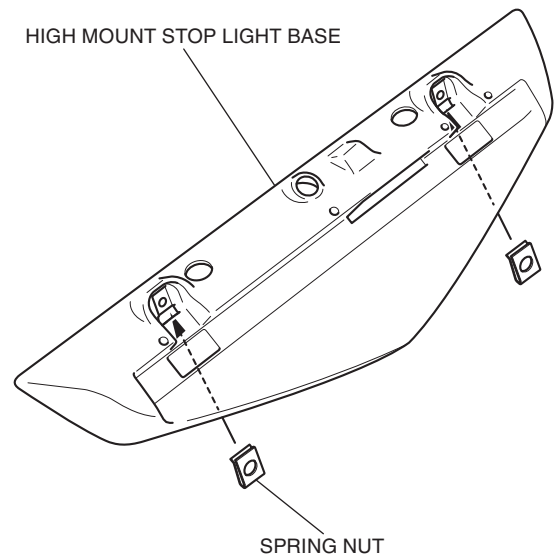

25. Attach the rubbers as shown.

Attach the cushions with the dimensions as shown.

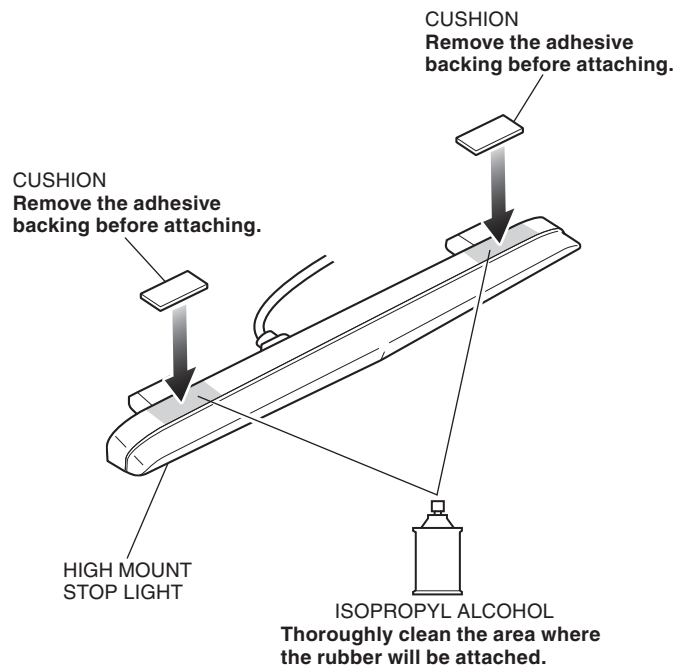
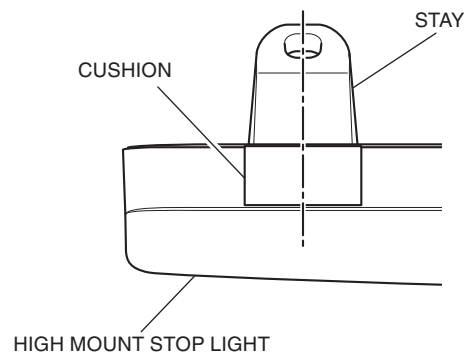

26. Route the high mount stop light harness as shown.

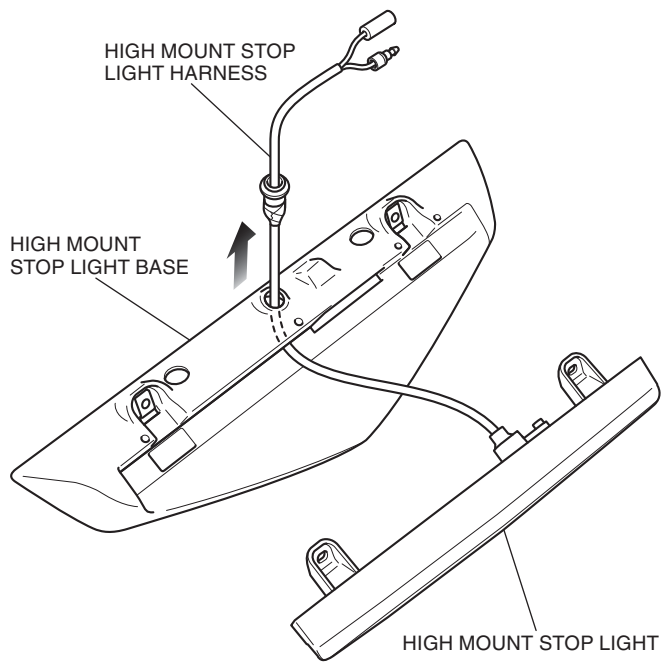

27. Install the high mount stop light as shown.

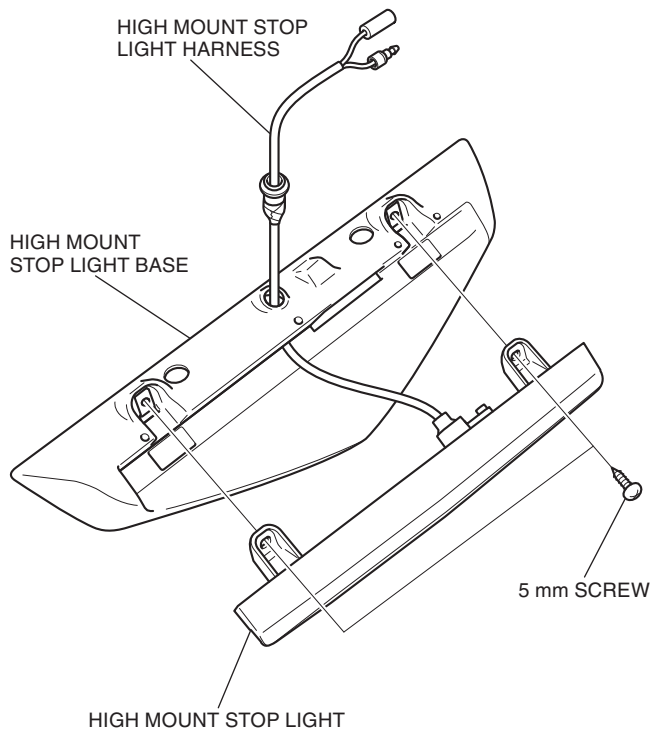

28. Route the high mount stop light harness as shown.

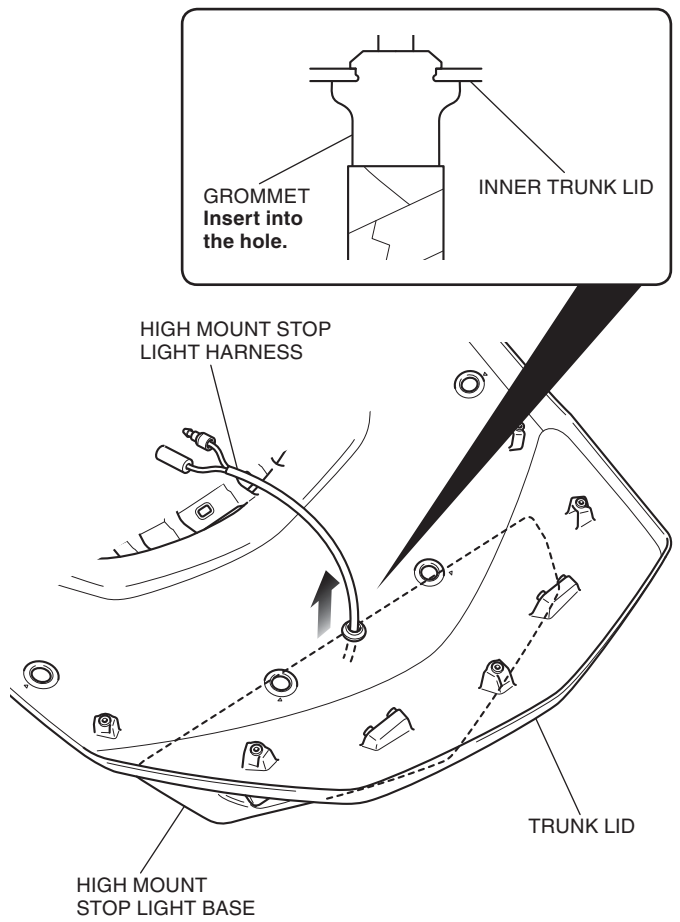

29. Clean the surface of the area shown using isopropyl alcohol.

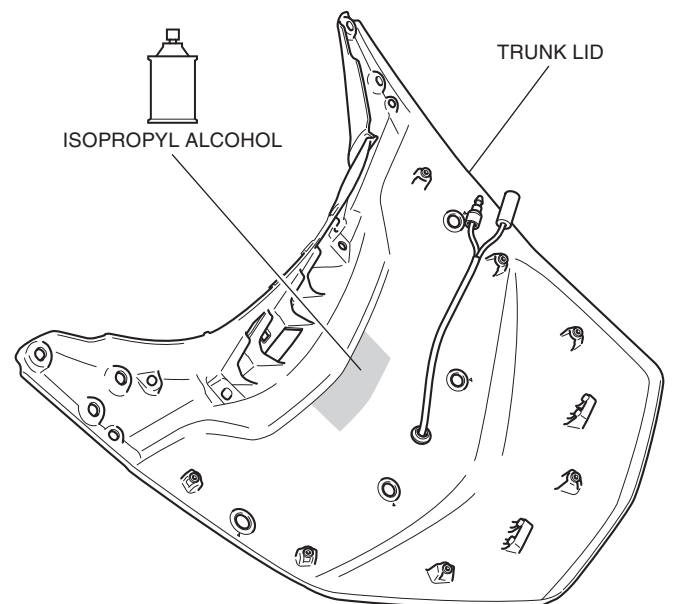

30. Attach the cushion tape as shown.

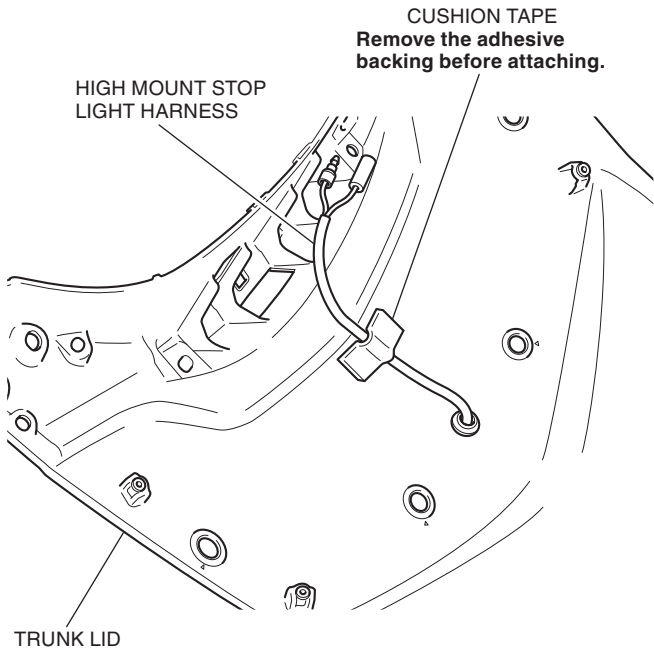

31. Perform step 19 to 22 on the trunk sub harness (sold separately) installation instructions.

32. Connect the high mount stop light harness and install the inner trunk lid to the trunk lid as shown.

- Confirm that any wire harness is not caught or too tight.

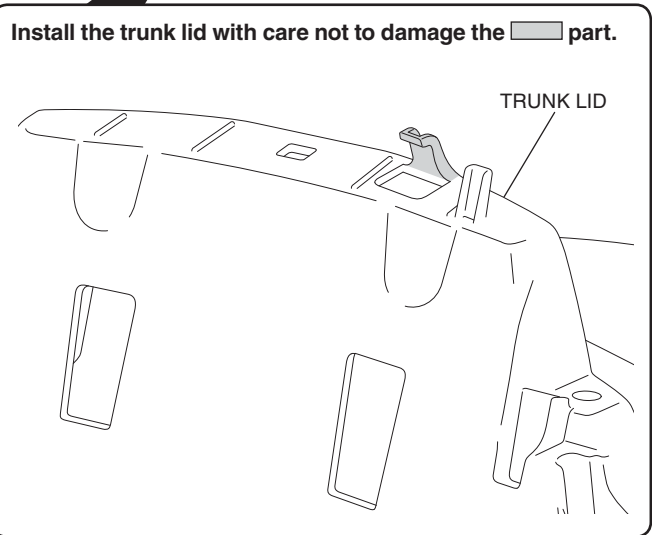
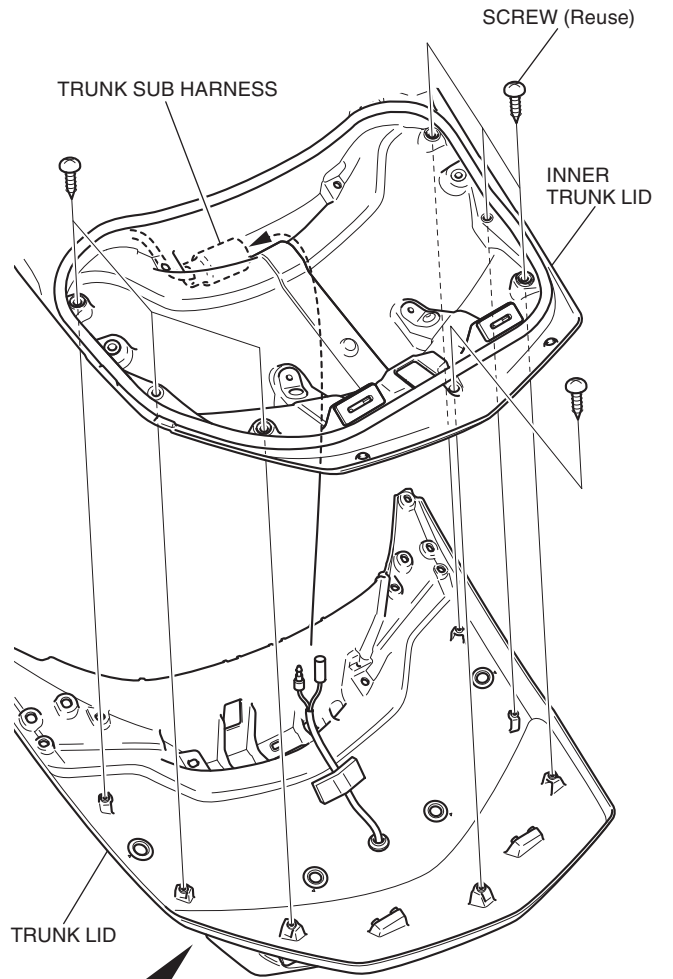

33. Store the terminal in the harness boot as shown.

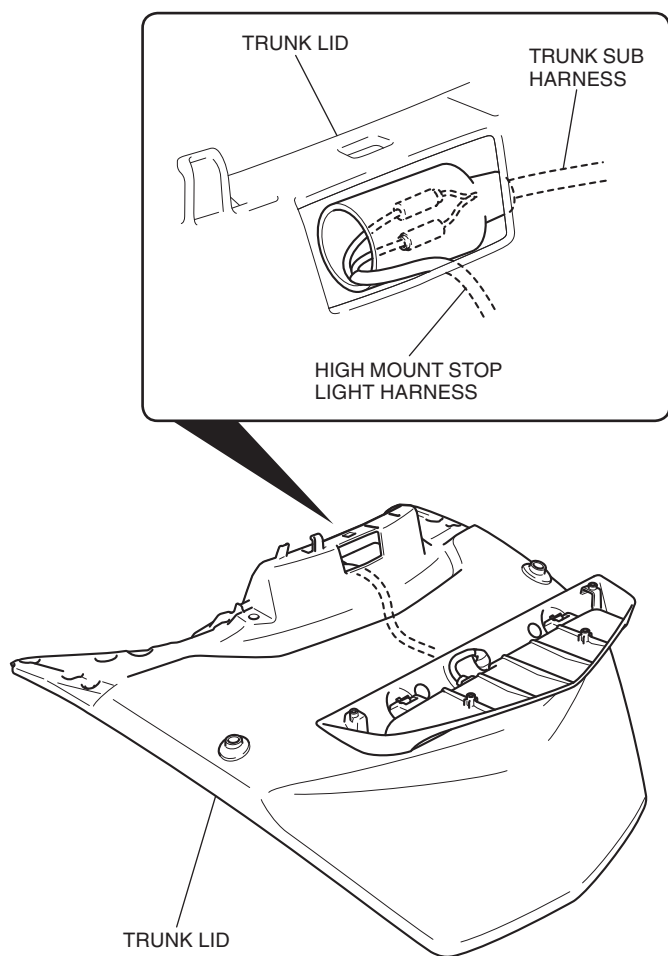

34. Install the striker rods as shown.

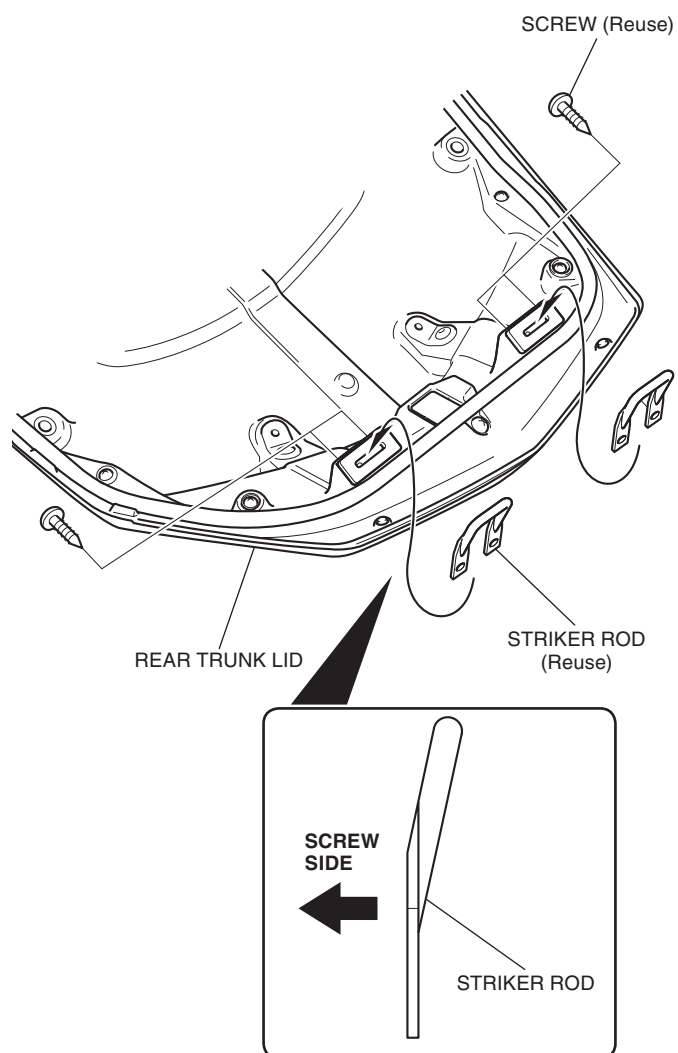

35. Apply dish soap solution to the position shown.

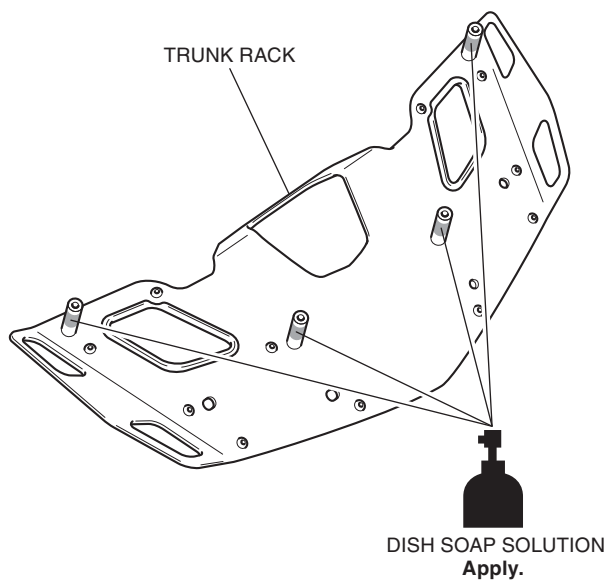

36. Install the trunk rack as shown.

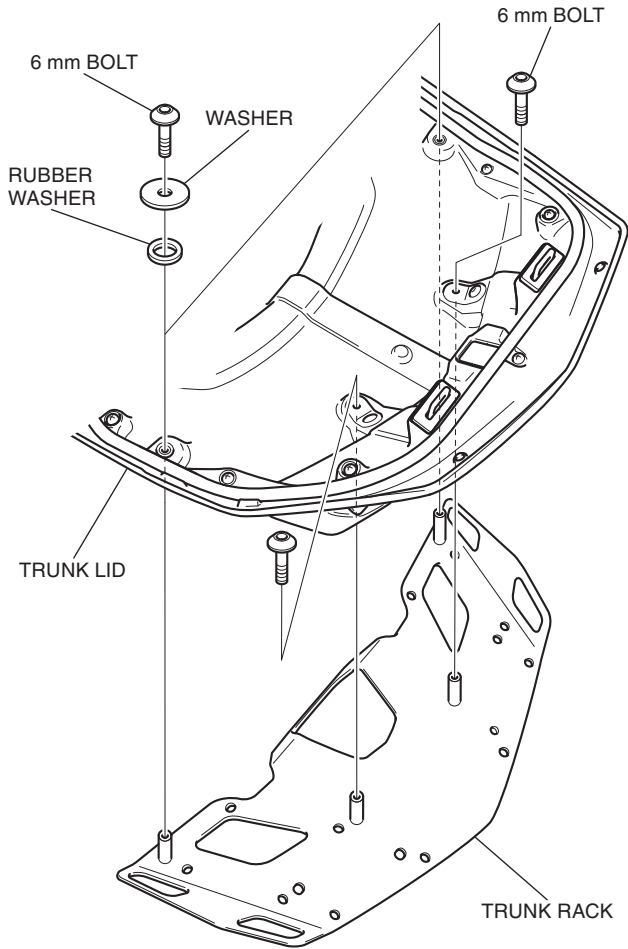

37. Install the high mount stop light as shown.

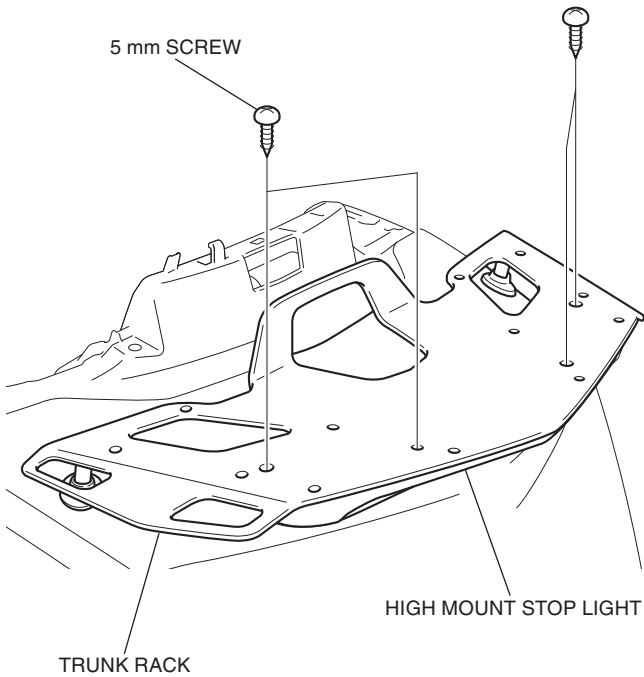

38. Install the left rack top cover as shown.

- Repeat on the right side.

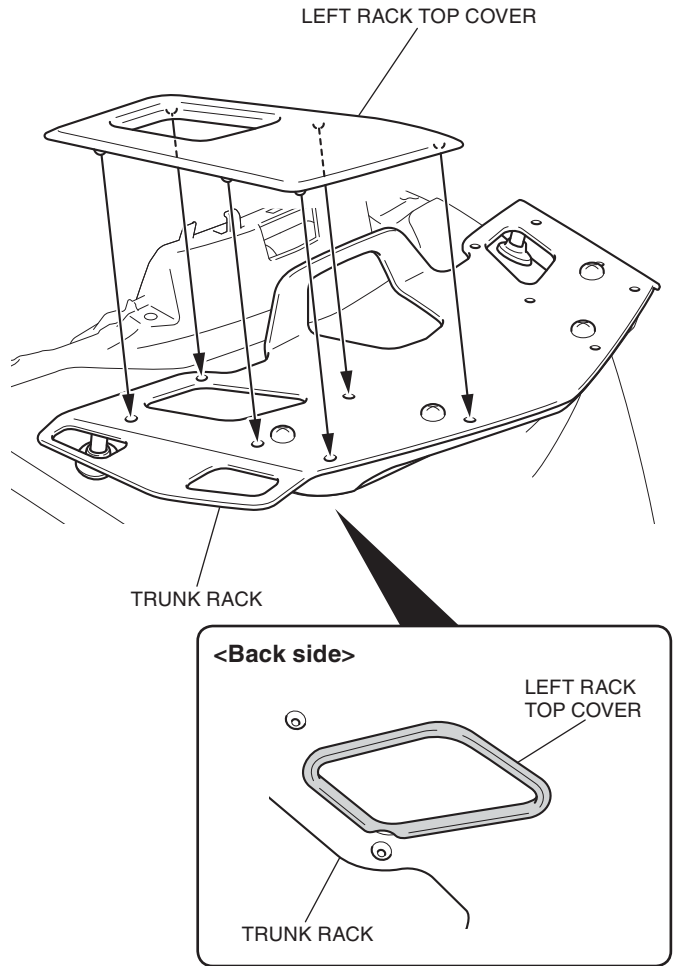

39. Perform step 23 to 29 on the trunk sub harness (sold separately) installation instructions.