



# INSTALLATION INSTRUCTIONS

Accessory

WHEEL STRIPE  
P/N 08F79-MKR-D10ZA

Application

CBR1000ST/SP

Publication No.

MII 17468

Issue Date

November 2020

Honda Dealer: Please give a copy of these instructions to your customer.

## PARTS LIST

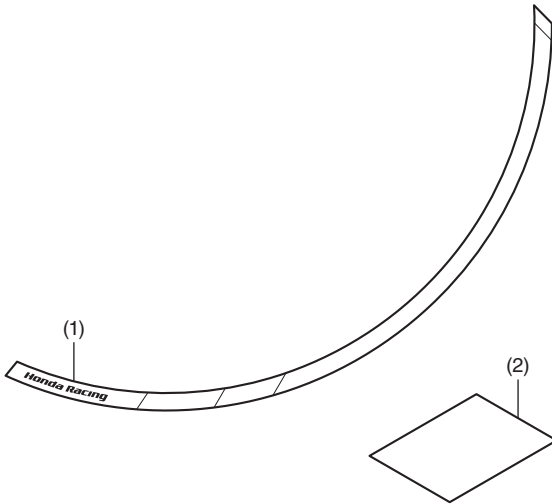

No.	Description	Qty
(1)	Wheel stripe	12
(2)	Installation Instructions URL	1

## TOOL AND SUPPLIES REQUIRED

Ruler  
Isopropyl alcohol  
Shop towel

## INSTALLATION

### ⚠ CAUTION

- To prevent burns, allow the engine, exhaust system, radiator, etc., to cool before installing the accessory.

### NOTE:

- Take care not to damage the painted surfaces of the motorcycle.
- Heat the bonding surfaces with a hair dryer if the ambient air temperature is below 21°C (70°F).
- The adhesive reaches full strength in 72 hours. Wait at least 24 hours before riding your motorcycle.

- Illustration shows CBR1000ST type, another type is similar.

1. Degrease the front wheel surface as shown.

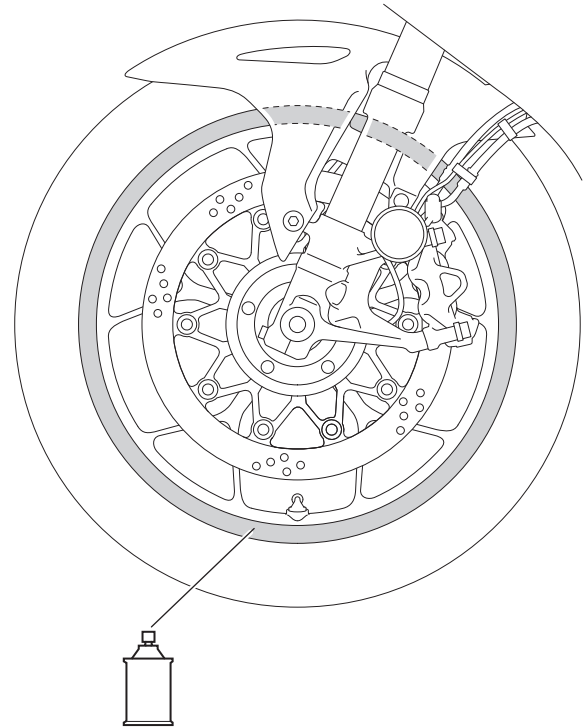

ISOPROPYL ALCOHOL  
Thoroughly clean the area where the wheel stripe will be attached.

2. Apply the wheel stripe as shown.
  - **Attach the wheel stripe in the middle of the rim width.**

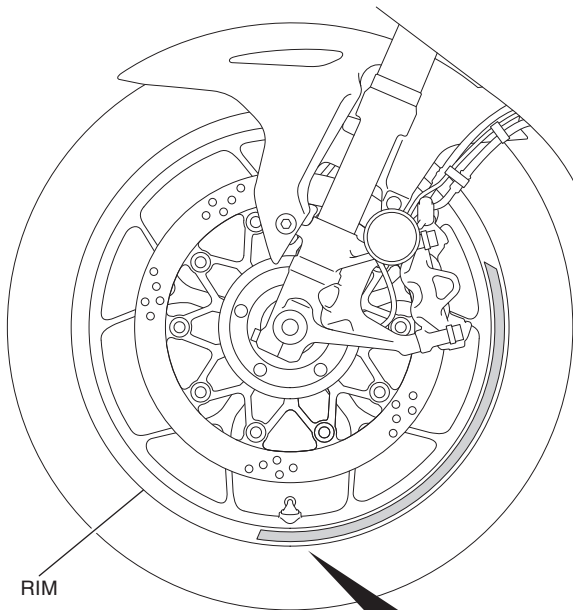

**Align the mark of the wheel stripe with the center of the valve as shown.**

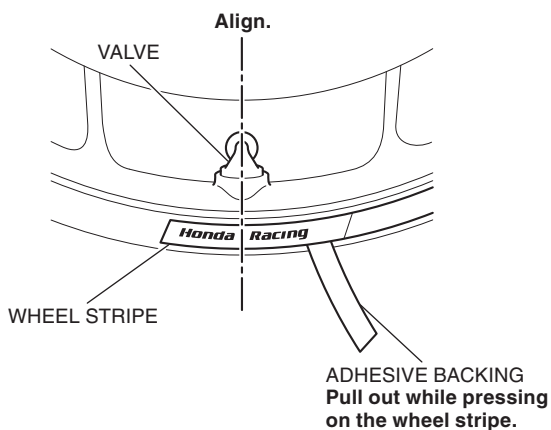

3. Apply the 2nd and 3rd wheel stripes in the locations shown.

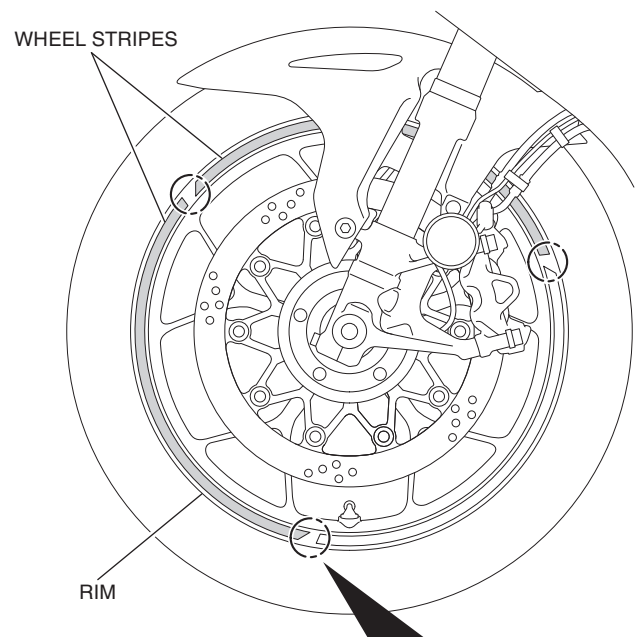

**Align the clearance between each wheel stripe.**

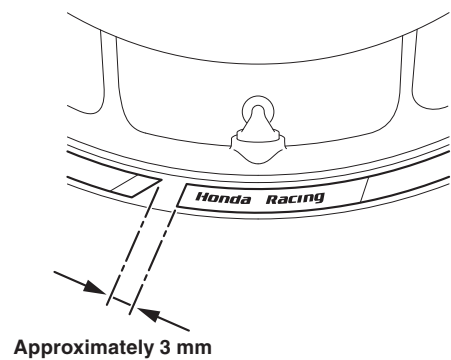

4. Press firmly on the installed wheel stripes to adhere.

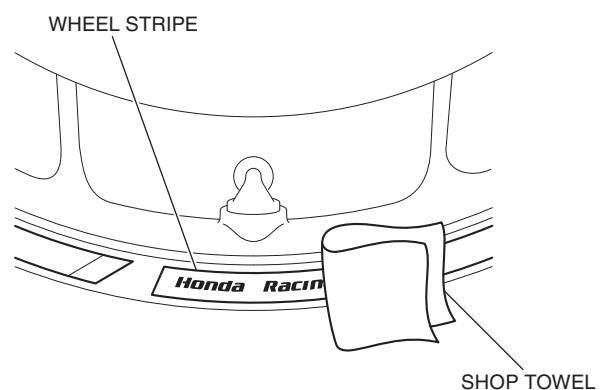

5. Repeat on the right side.
6. Attach stripes on the rear wheel in the same manner.