



# Plow Operator's Guide - Basic Guide to Plowing

Every plowing situation has the potential for personal injury. In order to minimize that risk, it is important that you read this Basic Guide carefully, familiarize yourself with the operation of your plow before having to use it, and be constantly safety oriented. In this Guide, we will set forth many of the basic rules of safe plow operation. However, because every plowing situation is different, your constant good judgment and consistent focus on safety are of great importance.

## TABLE OF CONTENTS:

General safety precautions .....	2-5
Plow Basics .....	6-9
How the Plow Works .....	10-11
Plow Accessories & Enhancements .....	12
Before you Plow .....	13-16
Plowing .....	17-18
Maintenance/Storage .....	19
Final Comment .....	19

### WARN INDUSTRIES OFF-ROAD PRODUCTS

12900 S.E. Capps Road  
Clackamas, OR 97015-8903 USA

Customer Service: 1-800-543-WARN (9276)  
Fax: 1-503-722-3000

[www.warn.com](http://www.warn.com)

## GENERAL SAFETY PRECAUTIONS

### Warnings and Cautions



As you read these instructions, you will see WARNINGS, CAUTIONS, NOTICES and NOTES. Each message has a specific purpose. WARNINGS are safety messages that indicate a potentially hazardous situation, which, if not avoided could result in serious injury or death. CAUTIONS are safety messages that indicate a potentially hazardous situation which, if not avoided, could result in minor or moderate injury. A CAUTION may also be used to alert against unsafe practice. CAUTIONS and WARNINGS identify the hazard, indicate how to avoid the hazard, and advise of the probable consequence of not avoiding the hazard. NOTICES are messages to avoid property damage. NOTES are additional information to help you complete a procedure. **PLEASE WORK SAFELY!**

 <h2 style="margin: 0;">WARNING</h2>	
	
<p style="text-align: center;"><b>CHEMICAL AND FIRE HAZARD</b></p> <p style="text-align: center;">Failure to observe these instructions could lead to severe injury or death.</p> <ul style="list-style-type: none"> <li>• <b>Always</b> remove jewelry and wear eye protection.</li> <li>• <b>Never</b> lean over battery while making connections.</li> <li>• <b>Always</b> verify area is clear of fuel lines, fuel tank, brake lines, electrical wires, etc. when drilling.</li> <li>• <b>Never</b> route electrical cables:             <ul style="list-style-type: none"> <li>- Across any sharp edges.</li> <li>- Through or near moving parts.</li> <li>- Near parts that become hot.</li> </ul> </li> <li>• <b>Always</b> insulate and protect all exposed wiring and electrical terminals.</li> <li>• <b>Always</b> install terminal boots as directed in installation instructions.</li> </ul>	

 <h2 style="margin: 0;">WARNING</h2>		
		
<p style="text-align: center;"><b>MOVING PARTS ENTANGLEMENT HAZARD</b></p> <p style="text-align: center;">Failure to observe these instructions could lead to severe injury or death.</p> <p><b>To avoid injury to hands or fingers:</b></p> <ul style="list-style-type: none"> <li>• <b>Always</b> keep hands clear of rope, hook loop, hook and fairlead opening during installation, operation and when spooling in or out.</li> <li>• <b>Always</b> use extreme caution when handling hook and rope during spooling operations.</li> <li>• <b>Always</b> use supplied hook strap whenever spooling rope in or out, during installation, and during operation.</li> <li>• <b>Always</b> keep vehicle in sight during winching operation.</li> <li>• <b>Always</b> wear heavy leather gloves when handling rope.</li> <li>• <b>Always</b> plow cautiously, impact with hidden or stationary object may cause the vehicle to stop suddenly or go out of control.</li> <li>• <b>Never</b> operate the vehicle on slopes greater than 10 degrees with the plow installed.</li> <li>• <b>Never</b> stand or ride on the plow.</li> <li>• <b>Never</b> remove the springs and hard fixture the blade to the plow base or vehicle. Doing so will prevent the plow from tripping (rollover) during an impact with a low-lying object and possibly damage the plow, vehicle, or eject the rider from the vehicle causing serious injury or death.</li> </ul>		

 <h2 style="margin: 0;">WARNING</h2>	
	
<p style="text-align: center;"><b>FALLING OR CRUSHING HAZARD</b></p> <p style="text-align: center;">Failure to observe these instructions could lead to severe injury or death.</p> <ul style="list-style-type: none"> <li>• <b>Never</b> use winch to lift or move persons.</li> <li>• <b>Never</b> use winch as a hoist or to suspend a load.</li> <li>• <b>Never</b> operate winch with less than 5 wraps of rope around the drum. Rope could come loose from the drum, as the rope attachment to the drum is not designed to hold a load.</li> </ul>	

## GENERAL SAFETY PRECAUTIONS



### WARNING

#### MOVING PARTS ENTANGLEMENT HAZARD

Failure to observe these instructions could lead to severe injury or death.

- **Always** stay clear of moving parts and joints.
- **Always** keep others away when operating or adjusting plow.
- **Always** perform regular inspections and maintenance on the plow mechanism, fasteners, rope and related hardware.
- **Always** replace all worn or damaged parts before operating.
- **Never** operate this WARN product with damaged or missing parts.
- **Always** drive slowly over bumpy and rough terrain. Driving at speeds that cause the plow to bounce while in the up position may cause the lift system to back-drive, lowering the plow down. This may result in the plow impacting a stationary object and cause damage to the vehicle and operator injury or death.
- **Always** drive at speeds such that the plow does not bounce and be aware of the plow position while driving at all times.
- **Never** raise the plow to a solid (stall/lock) position against vehicle, as it may damage the vehicle lift device and plow.
- **Always** wear a helmet and appropriate riding gear when operating the vehicle.
- **Always** store the plow system in a dry place when not in use.
- **Always** lower the plow to the down position before leaving the vehicle unattended.
- **Never** operate the plow near bystanders.
- **Never** be near or contact the plow or lifting device while the plow is being raised or lowered.
- **Always** operate plow vehicle with care. Vehicle weight balance and stability can be greatly changed when a plow is attached and when the vehicle is pushing a loaded plow. With this change, steering and vehicle control will be different.
- **Always** use appropriate and adequate care in lifting components into place.
- **Always** insure components will remain secure during installation and operation.
- **Always** tighten all nuts and bolts securely, per the installation instructions.



### WARNING

#### MOVING PARTS ENTANGLEMENT HAZARD

Failure to observe these instructions could lead to severe injury or death.

To avoid injury to hands or fingers:

- **Never** remove the hook from the end of the winch rope. The hook prevents the end of the winch rope from being pulled into the roller-fairlead. Removal of the hook increases the chance that fingers or other extremities may be pulled into the roller-fairlead causing personal injury. Leave the winch hook on and always follow safe winching techniques as described in the Winching Guide included with your winch.
- **Never** winch with the rope outside of the roller-fairlead. Doing so can result in severe vehicle damage and rope wear that can cause the winch rope to break suddenly and potentially cause destructive vehicle damage and major injury or death to riders and bystanders. Always route the rope through the roller-fairlead before winching.
- **Always** check the winch for back-driving and rope nesting before plowing. Failure to do so may cause the plow to creep downward when in the up position. If the plow creeps down low enough, the blade may hit a stationary object ejecting the rider from the vehicle and causing serious injury or death.
- **Always** check lift mechanism, straps or winch rope integrity before plowing. Failure to do so may cause the plow to drop suddenly from the up position and impact a low-lying object, potentially ejecting the rider from the vehicle and causing serious injury or death.
- **Always** replace winch rope if appears worn or frayed before plowing.
- **Always** be sure the latch lever handle is fully engaged before plowing. In some instances it may be necessary to push the handle to engage it into the plow base. Failure to properly engage the plow may result in loss of vehicle control which can lead to vehicle damage, personal injury, or even death.
- **Always** operate the vehicle at a low speed with the blade installed. Never exceed 5 mph (8 km/h), even with blade up. Use low range if vehicle is equipped.

## GENERAL SAFETY PRECAUTIONS



### CAUTION

#### MOVING PARTS ENTANGLEMENT HAZARD

Failure to observe these instructions could lead to minor or moderate injury.

##### General Safety:

- **Always** know your winch. Take time to fully read the Installation Guide and the Basic Guide to Winching Techniques in order to understand your winch and its operation.
- **Never** operate this winch if you are under 16 years of age.
- **Never** operate this winch when under the influence of drugs, alcohol or medication.
- **Never** exceed winch or rope capacity listed on product data sheet. Double line using a snatch block to reduce winch load.

##### Installation Safety:

- **Always** choose a mounting location that is sufficiently strong to withstand the maximum pulling capacity of your winch.
- **Always** use factory approved mounting hardware, components, and accessories.
- **Always** use grade 5 (grade 8.8 metric) or better mounting hardware.
- **Always** power winch with only the recommended electrical system voltage. See the winch specification sheet for details.
- **Never** weld mounting bolts.
- **Always** use care when using longer bolts than those supplied from factory. Bolts that are too long can damage winch and/or prevent the winch from being mounted securely.
- **Always** mount the winch and attach the hook to the rope's end loop before connecting the electrical wiring.
- **Always** position fairlead with WARNING label on top.
- **Always** spool the rope onto the drum in the direction specified by the winch warning label on the winch and/or documentation. This is required for the automatic brake (if so equipped) to function properly.
- **Always** prestretch wire rope and respool under load before use. Tightly wound wire rope reduces chances of "binding", which can damage the rope.



### CAUTION





#### MOVING PARTS ENTANGLEMENT HAZARD

Failure to observe these instructions could lead to minor or moderate injury.

##### Winching Safety:

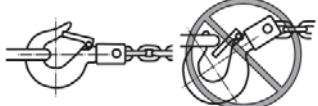
- **Always** inspect, rope, hook, and slings before operating winch. Frayed, kinked or damaged rope must be replaced immediately. Damaged components must be replaced before operation. Protect parts from damage.
- **Never** leave remote control plugged into winch when free spooling, rigging, or when the winch is not being used.
- **Never** hook rope back onto itself. This damages the rope.
- **Always** use a choker chain, choker rope, or tree trunk protector on the anchor.
- **Always** remove any element or obstacle that may interfere with safe operation of the winch.
- **Always** take time to use appropriate rigging techniques for a winch pull.
- **Always** be certain the anchor you select will withstand the load and the strap or chain will not slip.
- **Never** engage or disengage clutch if winch is under load, rope is in tension or drum is moving.
- **Always** select an anchor point as far away as possible. This will provide the winch with its greatest pulling power.
- **Never** touch rope or hook while in tension or under load.
- **Never** touch rope or hook while someone else is at the control switch or during winching operation.
- **Always** stand clear of rope and load and keep others away while winching.
- **Always** be aware of stability of vehicle and load during winching, keep others away. Alert all bystanders of any unstable condition.
- **Never** use winch to secure a load.
- **Always** keep wired remote control lead clear of the drum, rope and rigging. Inspect for cracks, pinches, frayed wires or loose connections. Replace remote control if damaged.
- **Always** pass wired remote control through a window to avoid pinching lead in door, when using remote inside a vehicle.
- **Never** leave remote control where it can be activated during freespooling, rigging, or when the winch is not being used.
- **Always** require operator and bystanders to be aware of vehicle and or load.

## GENERAL SAFETY PRECAUTIONS

 <b>CAUTION</b>	<b>NOTICE</b>
	<b>AVOID WINCH AND EQUIPMENT DAMAGE</b>
<b>MOVING PARTS ENTANGLEMENT HAZARD</b> Failure to observe these instructions could lead to minor to moderate injury. <ul style="list-style-type: none"><li>• <b>Always</b> use a hook with a latch</li><li>• <b>Always</b> ensure hook latch is closed and not supporting load.</li><li>• <b>Never</b> apply load to hook tip or latch. Apply load only to the center of hook.</li><li>• <b>Never</b> use a hook whose throat opening has increased, or whose tip is bent or twisted.</li></ul>	<ul style="list-style-type: none"><li>• <b>Always</b> avoid side pulls which can pile up rope at one end of the drum. This can damage rope or winch.</li><li>• <b>Always</b> ensure the clutch is fully engaged or disengaged.</li><li>• <b>Never</b> use winch to tow other vehicles or objects. Shock loads can momentarily exceed capacity of rope and winch.</li><li>• <b>Always</b> avoid "powering out" for extended distances. This causes excess heat and wear on the winch motor and brake.</li><li>• <b>Always</b> use care to not damage the vehicle frame when anchoring to a vehicle during a winching operation.</li><li>• <b>Never</b> "jog" rope under load. Shock loads can momentarily exceed capacity of rope and winch.</li><li>• <b>Never</b> use winch to secure a load during transport.</li><li>• <b>Never</b> submerge winch in water.</li><li>• <b>Always</b> store the remote control in a protected, clean, dry area.</li><li>• <b>Always</b> double line or pick distant anchor point when rigging. This maximizes pulling power and avoids overloading the winch.</li></ul>
 <b>CAUTION</b>	
 	
<b>CUT AND BURN HAZARD</b> Failure to observe these instructions could lead to minor or moderate injury. <b>To avoid injury to hands and fingers:</b> <ul style="list-style-type: none"><li>• <b>Always</b> wear heavy leather gloves when handling a rope.</li><li>• <b>Never</b> let rope slip through your hands.</li><li>• <b>Always</b> be aware of possible hot surface at winch motor, drum or rope during or after winch use.</li></ul>	

## PLOW BASICS

---

**⚠ WARNING**

Always perform regular inspections and maintenance on the plow mechanism, fasteners, rope and related hardware. Always operate the vehicle at a low speed with the blade installed. Never exceed 5 mph (8 km/h), even with blade up. Use low range if vehicle is equipped.

The WARN ProVantage plow system is divided into four separate kits. This allows the user to build a plow system per his/her liking and for the specific vehicle they own. A user must have one of each kit in order to have a working plow system. A complete plow system is made up of four kits :

1. PLOW BLADE
2. PLOW BASE ASSEMBLY
3. VEHICLE PLOW MOUNT
4. PLOW LIFT MECHANISM

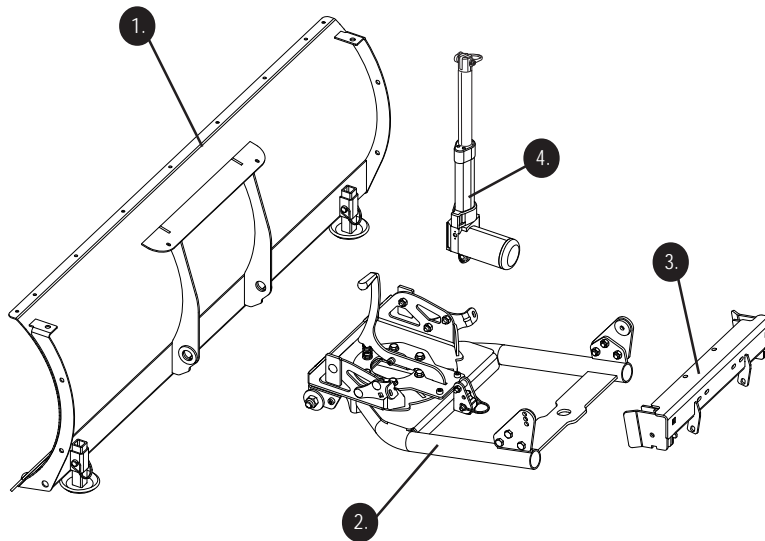

# PLOW BASICS

## Before You Begin:

To start, you should familiarize yourself with your WARN ProVantage plow and each of its components:

**CAUTION**  
 Never operate or install a winch without reading or understanding the operator's manuals. Always read and understand product manuals and warnings prior to installation and use.

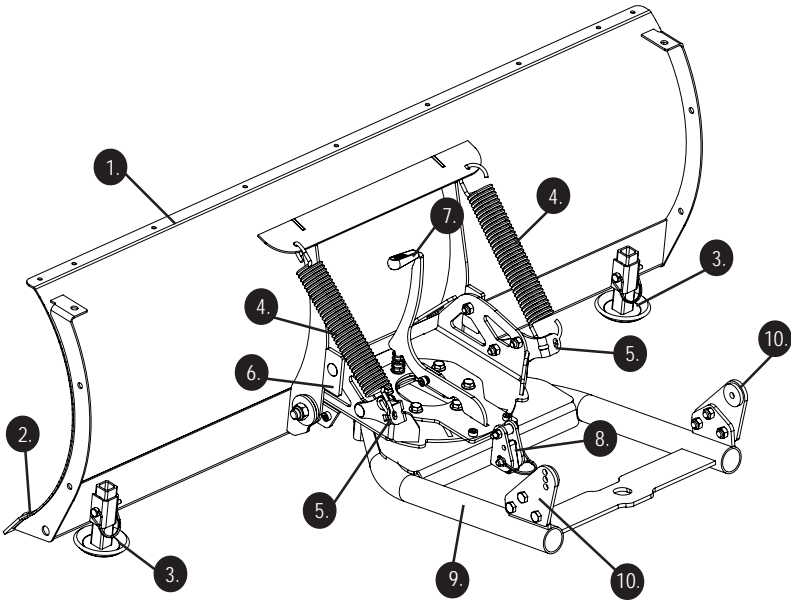

1. The **Plow Blade** is the primary component in the plow system. It is sold in various sizes and styles for different applications and vehicle sizes. The "Mold Board" is the curved face of the blade. The mold board is specifically designed to roll snow or plowed material. The ribs on the back and the structure on the bottom of the blade provide strength and rigidity.

2. The **Wear Bar** is the rectangular metal bar that is bolted to the bottom of the plow blade. This bar is the cutting edge and takes the brunt of the force and wear involved in plowing. It is a wear item and should be replaced if worn back to the adjacent mold board edge.

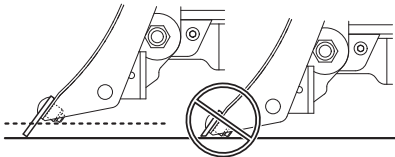

## PLOW BASICS

3. The **Plow Skid** is used to control the cutting/plowing height of the blade. It is designed to hold the blade wear bar off the ground at a user-selected height. These are also wear items and should be inspected often and replaced as needed.
4. The **Plow Blade Return Spring** restrains the plow blade in an upright position during plowing. If the blade wear bar contacts a very low non-movable object, the blade will roll over (forward) against the force of this spring.
5. The **Spring Tension Bracket** is used to tension the return spring and secure the spring end to the swivel base assembly. Be sure the left and right are on the same setting.

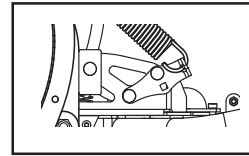
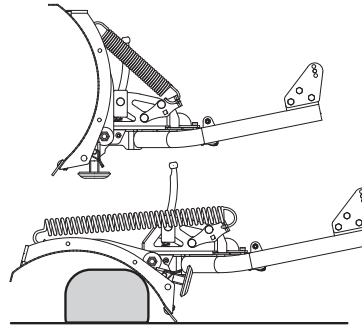

### ⚠ WARNING

Never remove the hook from the end of the winch rope. The hook prevents the end of the winch rope from being pulled into the roller-fairlead. Removal of the hook increases the chance that fingers or other extremities may be pulled into the roller-fairlead causing personal injury. Leave the winch hook on and always follow safe winching techniques as described in the Winching Guide included with your winch.

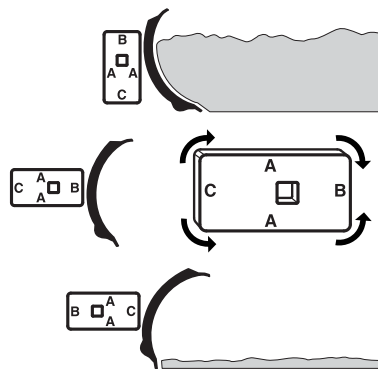

6. The **Stop Block** is used to set the plow blade attack angle. Rotating the stop blocks changes the scraping or cutting action of the blade. It provides three positions, to match plowing conditions. Be sure to set right and left blocks in the same position.
7. The **Plow Latch Lever** secures the plow blade pivot angle. Pressing this lever will release the latch and allow the blade to be rotated about a vertical axis. This lever is spring loaded so it will automatically engage when the base assembly slots align.



## PLOW BASICS

8. The **Plow Rope Guide** is used to route the winch rope to the rear cross-member of the plow tube assembly. The rope guide is pinned at the lower hole to allow the rope to be easily removed from the plow. Use of the rope guide prevents the rope end loop and swage from hanging up on the fairlead when the plow is fully raised.

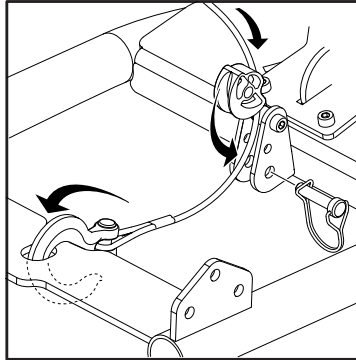

### ⚠ WARNING

Always perform regular inspections and maintenance on the plow mechanism, fasteners, rope and related hardware.

9. The **Plow Tube Assembly** is the main frame of the plow and attaches the plow blade to the vehicle by way of the plow mount. The tubes in this assembly transfer the pushing power of the vehicle into the plow blade. The front part of this assembly is the swivel or pivot platform. This platform supports the blade and allows the blade to pivot from side to side as selected by the operator. It also provides lift points for raising the plow blade with a winch or plow lift.

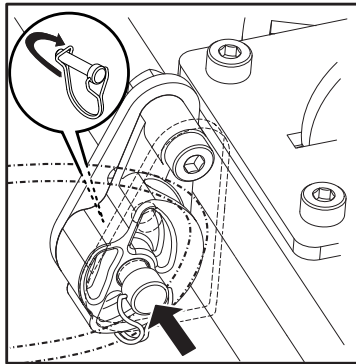

### ⚠ WARNING

Never remove the hook from the end of the winch rope. The hook prevents the end of the winch rope from being pulled into the roller-fairlead. Removal of the hook increases the chance that fingers or other extremities may be pulled into the roller-fairlead causing personal injury. Leave the winch hook on and always follow safe winching techniques as described in the Winching Guide included with your winch.

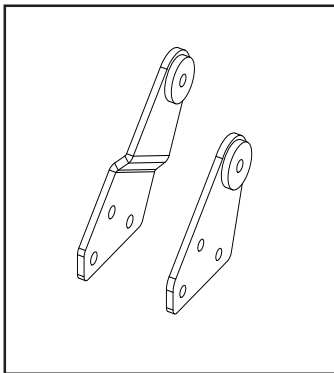

10. The **Plow Mounting Tabs** are supplied in the plow mounting kit. These are designed specific to each vehicle and attach the plow tube assembly to the plow mount. Each tab has a pivot disk or round piece of steel. This pivot disk fits into the mount cradle that provides alignment, allowing easy insertion and removal of the connecting pins.

## HOW THE PLOW WORKS

### ⚠ WARNING

Always check the winch for back-driving and nesting before plowing. Failure to do so may cause the plow to creep downward when in the up position. If the plow creeps down low enough, the blade may hit a stationary object ejecting the rider from the vehicle and causing serious injury or death.

Always check winch rope integrity before plowing. Failure to do so may cause the plow to drop suddenly from the up position and impact a low-lying object, potentially ejecting the rider from the vehicle and causing serious injury or death. Always replace winch rope if appears worn or frayed before plowing.

### ⚠ CAUTION

The operator must be in good health and free of joint problems if using the manual lift. The manual lift is intended for occasional and light duty plowing. WARN encourages persons who do heavy or frequent plowing to use a winch or electric actuator for a plow lifting device.

### Plow Mechanics

Now that you are familiar with your WARN plow and its components, we can begin reviewing how it works. The plow wear bar contacts the surface to be plowed and scrapes the material from the surface. The material is then pushed into the blade by the material on the plow surface and slides along the mold board. The material rolls over and

will not be effective as the material will not be able to roll over in front of the blade.

The blade attack angle can be adjusted and will change the blade cutting action. Generally, the blade should be set with the top lip in the back position (see page 15).

The plow gravel skids may be used to control how deep the blade

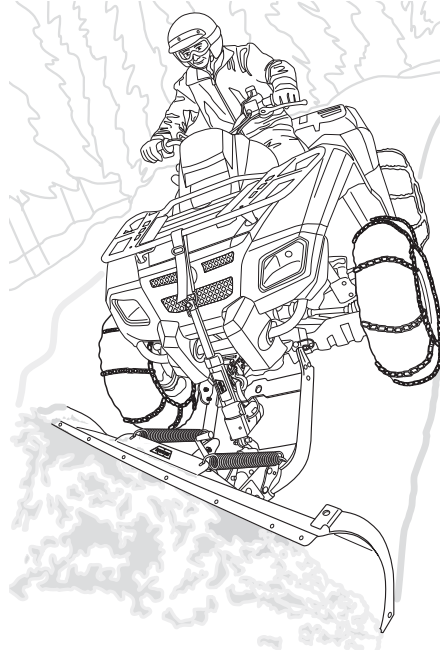

falls on top of the material in front of the plow as it reaches the top of the mold board.

When the blade is set at a pivot angle, the plowed material will roll over and flow to the side of the vehicle, leaving the area plowed.

As the material rolls over in front of the plow blade it will become deeper. The deeper the material the harder the vehicle will need to work to move the material. If the material is too deep or the vehicle has no traction, the plow

will cut into the material on the plow surface. The skids may be set to raise the wear bar the maximum distance off the surface. The area may be plowed to remove the top layer of material. A second pass may be made with the skids in a raised position that will allow the blade to remove all material down to the ground surface. Operating with the skids at maximum position may be optimal when grading material onto the surface or when trying to keep the wear bar from damaging the surface.

## HOW THE PLOW WORKS

### Plow Lift

The plow requires a lifting device. The lifting device may be a winch, a plow lift actuator or a manual device. If a winch is used, it is recommended that the operator replace the winch rope with the plow lift rope listed in the accessories section of the WARN Powersports catalog ([www.warn.com](http://www.warn.com)). It is also recommended, that the standard winch roller fairlead be replaced with the plow roller fairlead. This fairlead has a large bottom roller that will reduce rope wear. Using a winch to raise and lower a plow will cause rope wear. Always replace a damaged or worn rope. Consult the WARN Basic Guide to Winching booklet.

A winch rope may be rigged single or double line. A double line requires a pulley to be attached to the plow. The winch rope is then routed from the roller fairlead, around the pulley, and then back to the vehicle. This method reduces the load on the winch rope and reduces the plow lift speed. A slower lift speed provides better control of blade height and minimizes lifting plow up against vehicle or stalling lift mechanism.

For single line rigging, route the rope through the guide and to the back of the plow basket assembly.

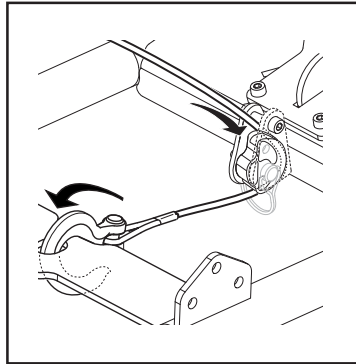

Single Line Rigging

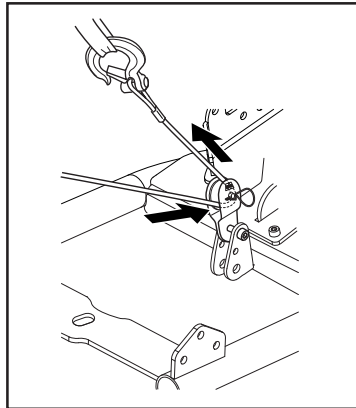

Double Line Rigging

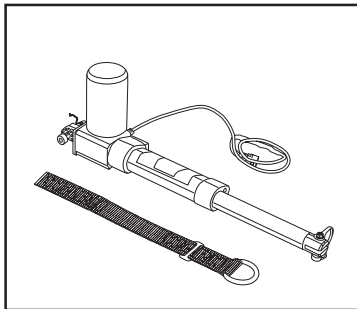

Plow lift

The plow lift is another method for lifting the plow. This device is specifically designed to lift the plow blade and does not use a rope. The actuator has internal parts that prevent it from extending due to plow weight. It also contains internal switches that automatically stop the device when fully extended or retracted.

### **⚠ WARNING**

Vehicle weight balance and stability can be greatly changed when a plow is attached and when the vehicle is pushing a loaded plow. With this change, steering and vehicle control will be different. **Always** operate the vehicle at a low speed with the blade installed. Never exceed 5 mph (8 km/h), even with blade up. Use low range if vehicle is equipped.

## PLOW ACCESSORIES AND ENHANCEMENTS

Alone the plow is an effective tool, but when used with certain accessories and enhancements your WARN plow can become even more versatile and productive. In this section we will review several of these items. Contact your local dealer or visit [www.warn.com](http://www.warn.com) to purchase your accessories.

- 1. Plastic Wear Bar** an ultra high molecular weight plastic bar that replaces the steel bar. This bar prevents wear of the blade and will minimize plow scraping on concrete or brick surfaces.
- 2. Blade Side Wall** controls run off of material as it is piled in front of blade. The heavy duty steel construction will prevent material from escaping and better allow you to move the material off to one side.
- 3. Snow Control Flap** is a flexible rubber flap that bolts to the top of the plow blade. This accessory keeps the snow (or light material) from flowing up over the blade, keeping the snow in front of the blade out of the operator's vision.
- 4. Plow lift** is another method for lifting the plow. This device is specifically designed to lift the plow blade and does not use a rope.
- 5. Plow Lift Rope** is a durable, synthetic rope that replaces the winch rope. This rope stands up to the repeated sharp angle pulls used to lift a heavy plow blade. Use this rope with the Plow Roller Fairlead for maximum rope life.
- 6. Roller Fairlead for Plow Lifting** designed for use with Warn winches that raise and lower the plow blade. The larger diameter lower roller reduces wear of the rope.
- 7. Power -Pivot** replaces the pivot latching system on the plow. This heavy duty electric device will pivot the plow blade in either direction with the push of a button. It is powerful enough to rotate your blade while plowing. Plow loads are transmitted to the base through a pawl system, protecting the 4 stage planetary drivetrain. This accessory greatly improves productivity.
- 8. Plow Markers** clearly mark the corners of your blade. These markers are flexible and two feet high to improve plow visibility when plowing close to objects in deep snow.

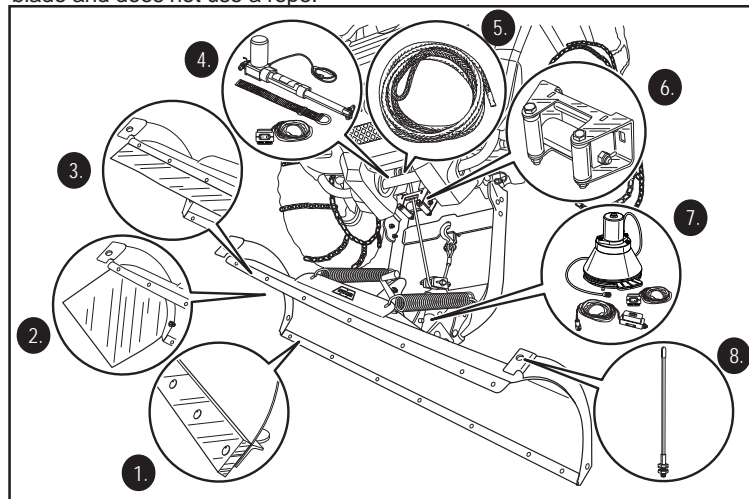

## BEFORE YOU PLOW

### Install the Plow

Make sure that the plow and vehicle are on flat, level surface before attempting to attach the plow to the vehicle mount. The vehicle engine should be off, transmission should be in park and/or the parking brake set. The front wheels should be straight and the plow blade pivot angle should be set to the straight position before installing the plow.

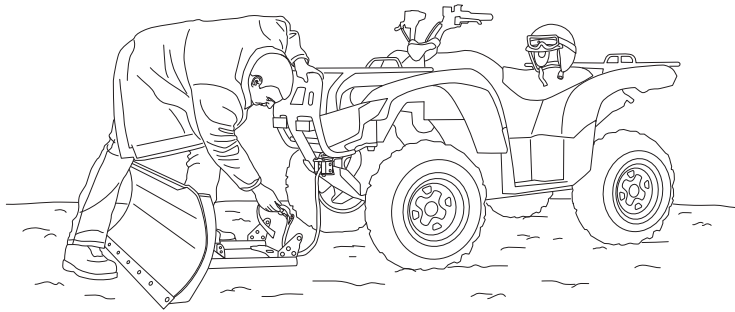

### ⚠ WARNING

Always be sure the latch lever handle is fully engaged before plowing. In some instances it may be necessary to push the handle to engage it into the plow base. Failure to properly engage the plow may result in loss of vehicle control which can lead to vehicle damage, personal injury, or even death.

Debris such as rocks, dirt, and branches can become lodged in the plow mount while operating the vehicle without the plow. Inspect the mount for any debris, damage and to make sure fasteners are properly torqued before installing or using the plow.

The plow retaining pins are secured to the mount by a bail. This bail can become damaged with use. Inspect the bail to make sure that it locks firmly to the mount. Remove the pin and bend the bail wire as needed to insure that it fits tightly to the mount.

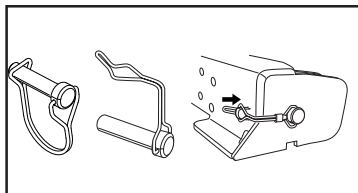

### Mold Board Preparation

The mold board surface has a nonstick material in the coating from the factory. However, like all nonstick surfaces, this coating will wear out over time. A surface modifier such as wax or nonstick spray may be applied to the mold board surface periodically to produce the best material roll.

### ⚠ CAUTION

Always inspect, rope, hook, and slings before operating winch. Frayed, kinked or damaged rope must be replaced immediately. Damaged components must be replaced before operation. Protect parts from damage.

## BEFORE YOU PLOW

### Setting Spring Tension

The spring brackets on the WARN plow have two specifically designed positions. The stiff setting will position the bracket in a lower position with the end of spring closer to vehicle. The softer setting will position the bracket more upright.

The stiff setting will produce the highest blade rollover force. Using the stiff spring position with the most aggressive (forward) blade attack angle position will produce the highest scraping action, useful for gravel driveway maintenance or plowing ice and snow clean.

The softer spring setting will lower the blade rollover force and should be used with lighter vehicles and typically the most aggressive (forward) blade attack angle.

Both spring brackets on the plow base will need to be rotated and set to the same position. Use a 17mm wrench to loosen the lower M10 lock nut securing each bracket. Use a 17mm wrench to remove the M10 lock nut and carriage bolt near the top of the bracket. Insert a 3/8" drive ratchet or breaker bar into a square bracket hole that will not be used for the bolt. Press the bracket down to align the holes in bracket and base. Secure each bracket with a M10 carriage bolt and lock nut. Torque all M10 nuts to 42 N-m (31 ft-lbs).

#### **⚠ WARNING**

Never remove the springs and hard fixture the blade to the plow base or vehicle. Doing so will prevent the plow from tripping (rollover) during an impact with a low-lying object and possibly damage the plow, vehicle, or eject the rider from the vehicle causing serious injury or death.

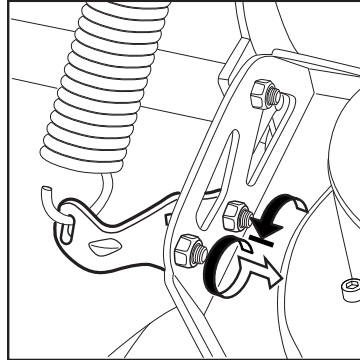

*Loosen M10 lock nut and carriage bolt securing brackets.*

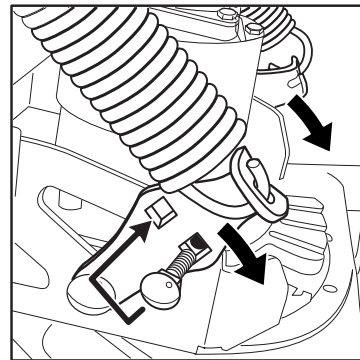

*Remove M10 nut and carriage bolt. Press bracket down to align holes in bracket and base.*

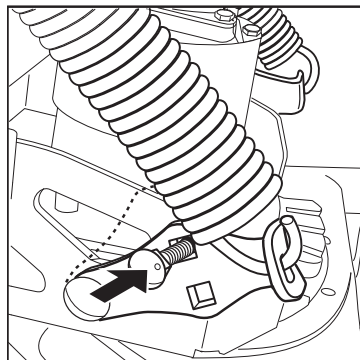

*Secure each bracket with M10 carriage bolt and lock nut.*

## BEFORE YOU PLOW

### Setting Blade Attack Angle

Usually one angle setting will work fine for most situations. The most aggressive attack angle (top of blade tipped forward) is recommended for use when moving sand and gravel. This setting will also produce better scraping action on ice or hardpack snow covered surfaces.

The middle attack angle setting will provide a good all around performance. This setting should be used with heavy or wet snow.

The least aggressive attack angle (blade tipped back) is recommended for use with deep snow. This setting allows the wear bar to slide under the snow and produce the most blade down force.

Both stop blocks on each side of the plow base will need to be rotated and set to the same position. Use a 17mm wrench to loosen the M10 nut. Release the spring tension by placing a 3/8" square drive ratchet into the spring bracket, loosen the bracket adjustment bolts, and apply force to the ratchet to relieve the upper adjustment bolt. Remove the bolt and allow the spring tension to go to zero. Repeat on the other side.

Use a 17mm wrench to loosen the M10 nut securing each block. Push the top edge of the blade away from the base until the block can be rotated to the desired position. Secure each block with lock nut and torque it to 42 N-m (31 ft-lbs). Reset the spring tension as desired and install, then tighten the spring bracket bolts.

#### CAUTION

Always wear heavy leather gloves when handling rope. Always follow adjustment procedure. Doing so will minimize potential for hand injury.

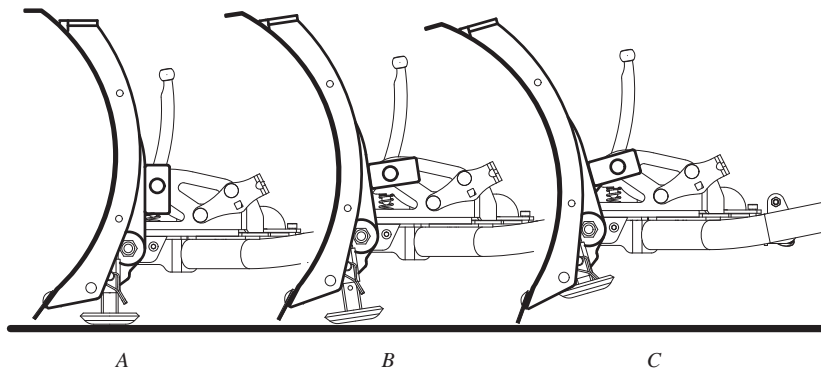
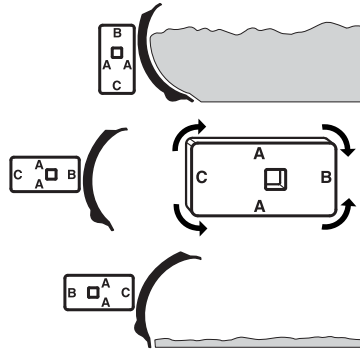

## BEFORE YOU PLOW

---

### Setting Vehicle Height

For best plow performance the plow platform and base must be parallel to the surface being plowed. The vehicle height should be adjusted prior to plowing to set the plow in the correct position. This can be done by adjusting the vehicle spring settings, adjusting tire pressure, and adding or removing weight from the vehicle. Be sure to include the weight of the driver on the vehicle when setting up the machine.

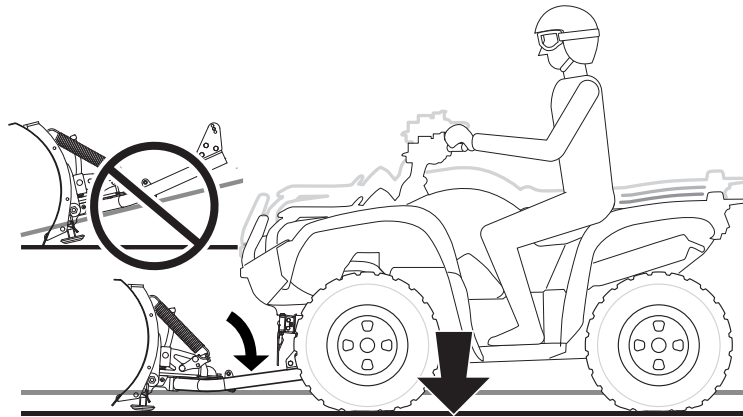

<p><b>⚠ WARNING</b></p> <p>Vehicle weight balance and stability can be greatly changed when a plow is attached and when the vehicle is pushing a loaded plow. With this change, steering and vehicle control will be different. <b>Always</b> operate the vehicle at a low speed with the blade installed. Never exceed 5 mph (8 km/h), even with blade up. Use low range if vehicle is equipped.</p>
---



## PLOWING

Every plowing situation is different. Always plan ahead before you start. It is up to you to analyze the situation and make the decisions necessary for the proper use of your WARN products. Some key things to remember when using your WARN plow:

- √ Vehicle weight balance and stability can be greatly changed when a plow is attached and when the vehicle is pushing a loaded plow. With this change, steering and vehicle control will be different.
- √ 5 MPH (8 KPH) maximum. Keep your speed low and pay attention to how the machine is responding to your control. The plow may impact unseen and immovable objects, causing a sudden change in vehicle control. Use low range and 4WD if the vehicle is so equipped.
- √ Keep bystanders away from the plowing route or path. Steering and vehicle control are different when plowing, changing reaction time.
- √ Wear proper safety equipment. Carefully review your vehicle manual and labeling.
- √ Inspect your equipment before and after each use. Get it repaired if damaged. This applies to the plow, winch (if used) and vehicle.
- √ Set your plow up for the conditions. Best performance is obtained with the right attack angle, spring tension and pivot angle. Too much cutting action will slow or stop your progress. Too little may not get the job done.
- √ Never plow side hills steeper than 10 degrees.

### **Step 1: PUT ON GLOVES & INSPECT YOUR EQUIPMENT**

Look for loose hardware, worn components and inspect for damage. Correct issues before you plow. Set blade pivot to straight position.

### **Step 2: POSITION THE BLADE ASSEMBLY AND VEHICLE**

Carefully move the vehicle and plow assembly to a flat level area and about 3' (1m) apart. Slowly move the vehicle towards the mounting tabs of the tube assembly until the push tube is between the front tires.

### **Step 3: ENGAGE THE PLOW ASSEMBLY TO THE VEHICLE MOUNT**

Lift the push tube at mounting tab end and slide plow assembly on wear bar, seating the alignment pilot disks into the mount cradle. If the plow is on a loose surface, you may need to work on one side and then the other.

### **Step 4: INSTALL THE CONNECTING PINS AND LATCH THE PIN BAIL**

On each side, install the connecting pin. You may need to wiggle the push tube assembly to allow the pin to easily insert. If you find difficulty, a tapered drift may help align the holes.

### **Step 5: ATTACH THE LIFT DEVICE**

If you are using a winch, put the winch in freespool and pull out 3 to 5 feet (1 to 2 meters) of wire rope. Route the rope through the rope guide and attach the hook to the cross member of the tube assembly as shown. Close the rope guide and insert the locking pin. When using another type of lifting device, carefully review and follow the instructions included with that device.

## PLOWING

### Step 6: CHECK THE LIFT DEVICE OPERATION

Lift and lower the plow. Note how far you can lift without stalling the lifting device or causing impact between the plow assembly and the vehicle. Do not over lift the plow during use.

### Step 7: SET THE BLADE ATTACK ANGLE, SKID HEIGHT, AND BLADE PIVOT ANGLE

See the plow blade labeling for tips on setting up the blade for the job at hand. If the material is deep, plow several thin layers at a relaxed attack angle, minimizing load on the plow and vehicle. Finish the job with an aggressive attack angle to leave a clean surface.

### Step 8: PLAN YOUR ROUTE AND WORK SCOPE

Make sure you know what is under the material you are plowing. Avoid impacting hidden objects. Be sure bystanders are aware of your activities and that they stay clear.

It is usually best to plow the outer edge of the area to be cleared. To plow a driveway, start by plowing the shoulder first. Move the material to either side of the driveway. This will clear the shoulder and allow for the material in the center to be thrown onto the shoulder or over the material removed from the shoulder.

### Step 9: SUIT UP TO OPERATE YOUR VEHICLE

Follow all warnings and wear the right safety equipment.

### Step 10: WORK SMARTLY. KEEP UNDER CONTROL AND PLOW CAREFULLY

Plowing changes how a vehicle handles (steering, stopping, and stability). Plow with care and do not rush. When you are done with your job, be sure to park the vehicle on flat level ground and set the brake (put in "park") prior to removing the plow. Inspect and maintain your equipment so that it is ready for your next use.

<p><b>⚠ WARNING</b></p> <p>Never operate the plow near bystanders.</p> <p>Always operate the vehicle at a low speed with the blade installed. Never exceed 5 mph (8 km/h), even with blade up. Use low range if vehicle is equipped.</p> <p>Always plow cautiously, impact with hidden or stationary object may cause the vehicle to stop suddenly or go out of control.</p> <p>Always stay clear of moving parts and joints. Always keep others away when operating or adjusting plow.</p>
---

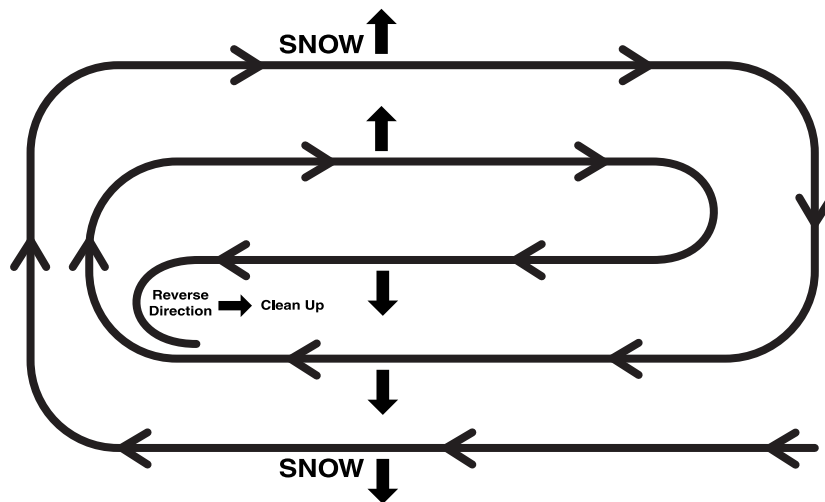

*Plowing Pattern*

## **MAINTENANCE/STORAGE AND FINAL COMMENT**

### **Maintenance**

Inspect the plow before each use. The mold board surface will become scratched with use. It is recommended to apply wax or a nonstick spray to the surface before plowing. This will prevent the snow from sticking to the blade and provide the best material roll.

Inspect the blade wear bar. This steel or plastic bar on the bottom of the blade will need to be replaced periodically over the life of the plow. The steel bar provides about ¾" (19mm) of wear material before requiring replacement. Some blades have a reversible bar that may be turned to double the life of the bar. This bar must be replaced before the retaining bolts and nuts begin to contact the ground.

The blade hinge bushings will require lubrication periodically for the best plow performance. Spray a light lubricating oil on both sides of the center blade ribs just above the large hinge bolt. This lubrication should run down the rib and into the bushing area. For better results the blade retaining M16 nuts and retaining washers should be removed to allow lubrication to be applied directly to the bushing.

The blade pivot bushing is located in the center of the plow base. Remove the plow from the vehicle and place the blade face down so that the plow base and bushing are vertical. Spray a light lubricating oil around the base retaining plate and then rotate the tube assembly a few times to either side. Repeating this a few times will allow the oil to enter the pivot bushing area. The base retaining plate may need to be removed for cleaning and thorough lubrication if the pivot assembly does not turn smoothly.

Inspect all fasteners to insure that they are tight. The fasteners on your plow must be torqued periodically to insure that they are tight. Torque the fasteners to the following specifications:

- 13mm (M8) Bolts – 17 N-m (12 ft-lb)
- 17mm (M10) Bolts – 42 N-m (31 ft-lb)
- 24mm (M16) Bolts – 138 N-m (100 ft-lb)

### **Storage**

Always clean off your plow by spraying with fresh water before storage. This will minimize corrosion from road salts or other chemicals. Once the plow is clean it should be removed from the vehicle. Spray pivots and bushings with light lubricating oil and place in storage area. The storage area should be clean and dry.

Always repair and lubricate prior to storage, making the plow ready for your next use.

### **Final Comment**

The Plow Operator's Guide cannot cover all the possible situations in which you may use your plow. The decisions you make will determine the final outcome. So think through each situation before you begin to move material. Read and understand all manuals, labels and tags. Always be mindful of your own safety and the safety of others.