

ACCESSORY SOCKET

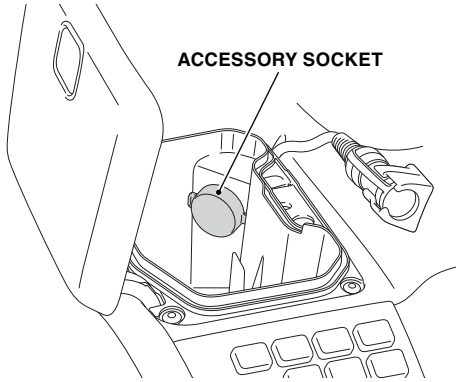

- The maximum power rating of connected accessories cannot exceed 36W (12V, 3A).
- Use accessories with the engine running to avoid discharging the battery.
- Switching the headlight to low beam when accessories are connected will help avoid discharging the battery.
- Do not use a cigarette lighter, as this can cause a malfunction.
- Cover the socket with the cap when it is not used to prevent entry of foreign objects.
- Carefully secure any connected devices, as vibrations may cause them to shift unexpectedly.
- Use only a 3A fuse when replacing the fuse in the accessory harness. Do not use any other fuse for replacement.

<LEFT FRONT POCKET INSIDE>



CENTERSTAND

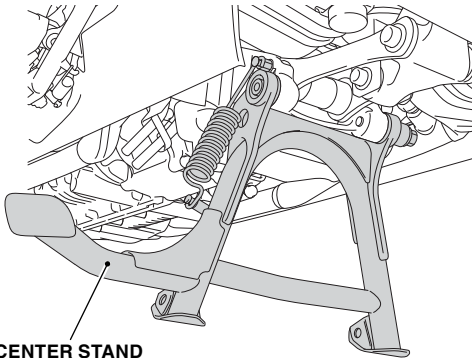

HOW TO USE THE CENTERSTAND

1. Look for a level parking area. If you can't park on a paved surface, make sure the ground surface is firm.
If you must park on an incline, aim the motorcycle uphill, leave the transmission in gear and position the rear tire against a curb at a 45 degree angle.
- **Make sure flammable materials such as dry grass or leaves do not come in contact with the exhaust system when parking your motorcycle.**

CENTER STAND

HEATED GRIPS

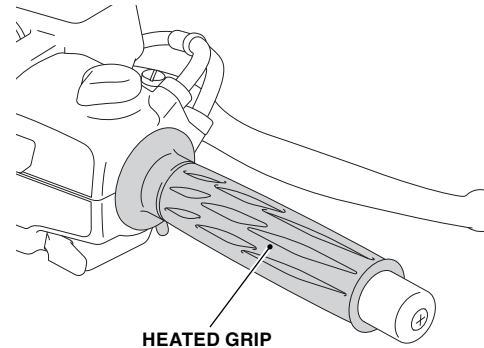

2. Use the centerstand to support the motorcycle while parked.
 - **To lower the centerstand, stand on the left side of the motorcycle. Hold the passenger handgrip attached to the seat. Press down on the tip of the stand with your right foot and, simultaneously, pull up and back on the passenger handgrip.**

- The heated grip control warms up the right and left grips of the handlebar for comfortable riding on a cold day.
 - The heated grip button is located on the right fairing panel.
- To operate, adjust the heated grip button with the engine running.

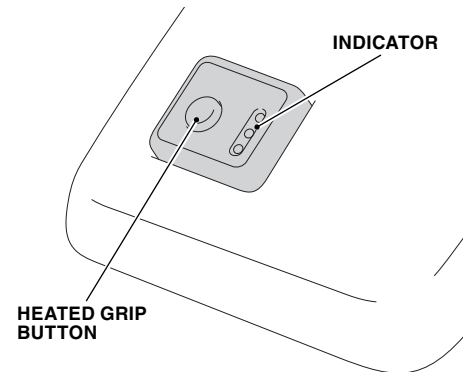
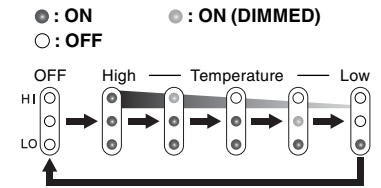

- Adjust the temperature by repeatedly pressing the button.
The temperature can be set to five levels.
- Do not leave the heated grip in the high position for a long time on a warm day.
Wear gloves to protect your hands from the heated grips.
- Do not use the heated grip with the engine at idle for an extended period. It may result in a low (or discharged) battery.

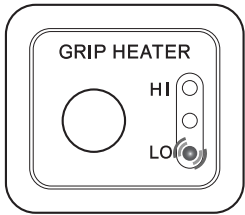

- INDICATOR OFF
- INDICATOR BLINKING

- If an indicator blinks, the battery is probably low. If the indicator continues to blink after riding for a while, charge or replace the battery.
- When you are making a temporary stop or riding at low speed, the battery voltage level may go down. This can turn off the heated grip automatically. The heater then resumes normal operation when the battery voltage level recovers after riding for a while. If you continue to have trouble with the heated grips, see your Honda dealer.

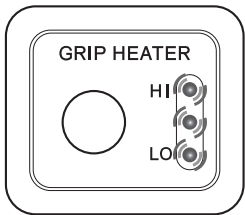

- INDICATOR OFF
- INDICATOR BLINKING

- If all three indicators blink, turn the ignition switch to the OFF position and then turn it back to the ON position.
- If indicators continue to blink, or if you have other trouble with the heated grips, see your Honda dealer.

REAR CARRIER

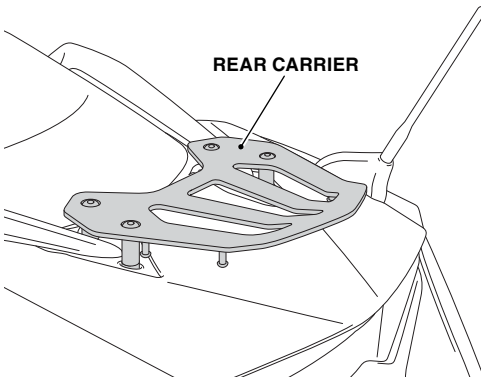

- Be sure to secure all cargo to prevent shifting.
- The weight of the cargo must not exceed the following maximum weight capacity:
6.6 lb (3.0 kg)

TALL WINDSCREEN

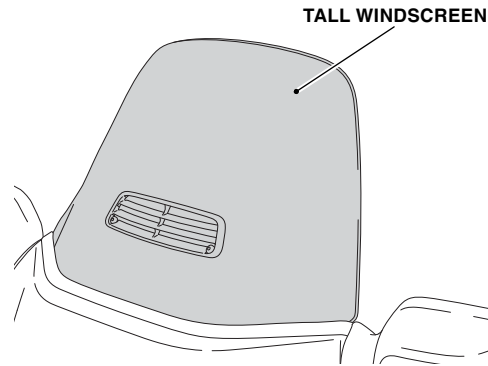

- Reduce speed when riding against a strong wind.
- Replace this windscreen with a new one if it is damaged or becomes excessively discolored.
- When this accessory becomes dirty, rinse it thoroughly with cool water to remove loose dirt, then wipe with a clean cloth or sponge. Do not use a brush to clean this accessory as it may scratch the surface.
- Never use organic solvents such as gasoline, thinner or benzene to clean this accessory. Also do not use acid or alkaline cleaners to clean this accessory. Wipe up spilled brake fluid at once as it may damage the plastic surface.
- Handle this accessory with care. It can be damaged when it is bent excessively or is subject to strong shock or impact.
- Select a firm, level surface when you park the motorcycle. Also bear in mind that strong wind can cause the motorcycle to topple to the ground.
- The windscreen vent can be opened and closed in five positions by operating the lever. Do not operate the lever while riding as it may interfere with your ability to control the motorcycle.

