

ACCESSORY SOCKET

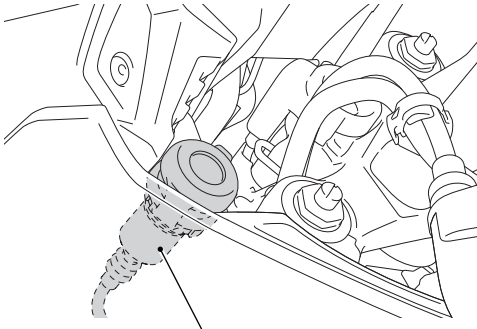

ACCESSORY SOCKET

- The maximum power rating of connected accessories is 36W (12V, 3A).
- Use accessories with engine running to avoid discharging the battery.
- Do not use a cigarette lighter, as this can cause a malfunction.
- Cover the socket with the cap when the accessory socket is not used to prevent entry of foreign objects.
- Carefully secure any connected devices, as vibrations may cause them to shift unexpectedly.
- Make sure that the cable of device connected to the accessory socket does not disturb the steering operation or riding. Do not pinch the cable to prevent from being damaged.

CENTERSTAND

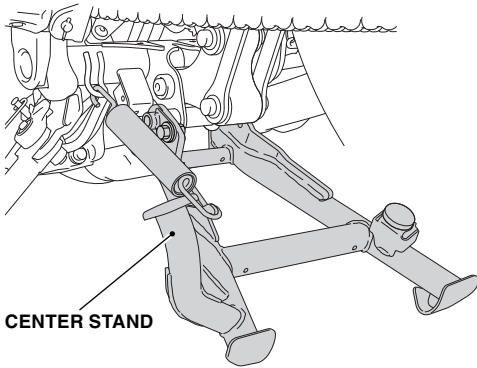

CENTER STAND

- Before starting your motorcycle, check that the side stand and the centerstand are fully retracted.
- Always choose a flat ground when setting the centerstand.

HOW TO USE THE CENTERSTAND

1. Park safely on a level ground and stop the engine.
2. Setting the centerstand.
 - **Let down the centerstand, stand on the left side of the motorcycle. Hold the left handle grip and the left grab rail or rear carrier. Press down on the tip of the stand with your right foot and, simultaneously, pull up and back.**

WIND DEFLECTOR

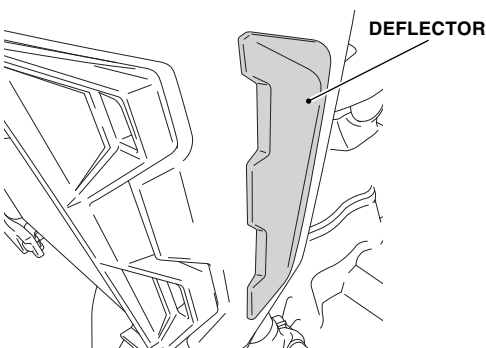

DEFLECTOR

- When this accessory becomes dirty, rinse it thoroughly with cool water to remove loose dirt, then wipe with a clean cloth or sponge. Do not use a brush to clean this accessory as it may scratch the surface.
 - Never use organic solvents such as gasoline, thinner and benzine to clean this accessory. Also do not use acid or alkaline cleaners to clean this accessory.
- Wipe up spilled brake or battery fluid at once as they may damage the surface.

LIGHT BAR

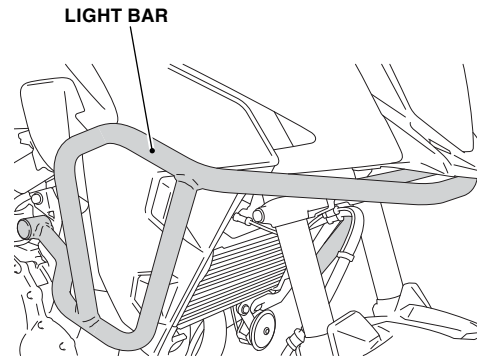

LIGHT BAR

- Do not attempt to move the motorcycle with holding front light bar and also to apply extra pressure on them. It may damage the motorcycle and light bar.
 - When this accessory becomes dirty, rinse it thoroughly with cool water to remove loose dirt, then wipe with a clean cloth or sponge. Do not use a brush to clean this accessory as it may scratch the surface.
 - Never use organic solvents such as gasoline, thinner and benzine to clean this accessory. Also do not use acid or alkaline cleaners to clean this accessory.
- Wipe up spilled brake or battery fluid at once as they may damage the surface.

HEATED GRIPS

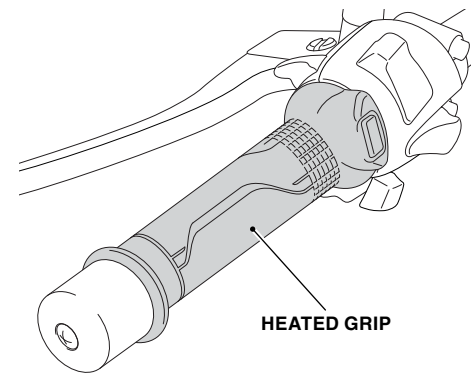

HEATED GRIP

HOW TO USE THE HEATED GRIP

- For operating instruction, refer to the Owner's Manual of the heated grip kit.

HAND GUARDS

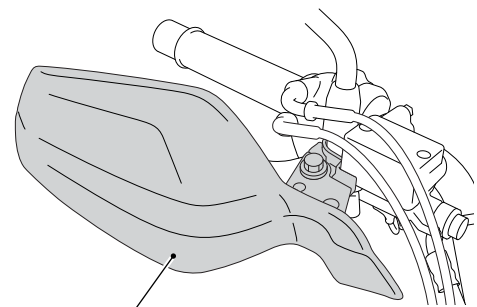

HAND GUARDS

- When this accessory becomes dirty, rinse it thoroughly with cool water to remove loose dirt, then wipe with a clean cloth or sponge. Do not use a brush to clean this accessory as it may scratch the surface.
 - Never use organic solvents such as gasoline, thinner and benzine to clean this accessory. Also do not use acid or alkaline cleaners to clean this accessory.
- Wipe up spilled brake or battery fluid at once as they may damage the surface.
- Handle this accessory with care. It can be damaged when it is bent excessively or is subject to strong shock or impact.

REAR CARRIER A

REAR CARRIER A

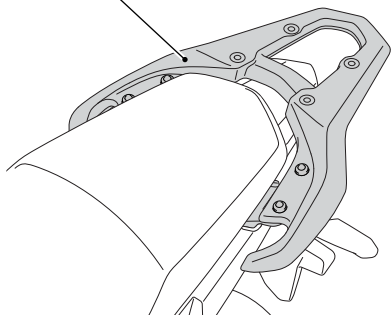

- The weight of the cargo must not exceed the following maximum load capacity:
6.6 lb (3.0 kg)
- When this accessory becomes dirty, rinse it thoroughly with cool water to remove loose dirt, then wipe with a clean cloth or sponge.
Do not use a brush to clean this accessory as it may scratch the surface.
- Never use organic solvents such as gasoline, thinner and benzine to clean this accessory. Also do not use acid or alkaline cleaners to clean this accessory.
Wipe up spilled brake or battery fluid at once as they may damage the surface.

REAR SEAT BAG

for Canada

REAR SEAT BAG

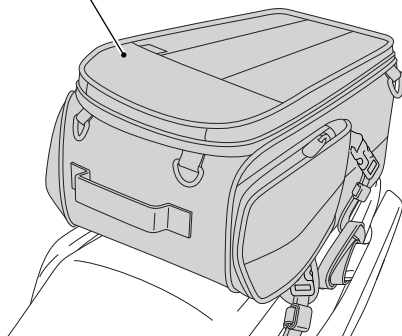

- The weight of the cargo must not exceed the following maximum weight capacity:
8.8 lb (4.0 kg)
- Be sure that the rear seat bag is installed securely before riding.
- Before riding, close the rear seat bag.
- The rear seat bag is not perfectly watertight, and water may enter when it rains, etc.
- Do not store valuables or fragile articles in the rear seat bag.
- To prevent burns, allow the engine, exhaust system, radiator, etc., to cool before installing and removing the accessory.
- When washing the motorcycle and when leaving the motorcycle, remove the rear seat bag.
- Do not let anybody ride on the rear seat bag and do not place luggage onto it.
- Never use organic solvents such as gasoline, thinner and benzine to clean this accessory. Also do not use acid or alkaline cleaners to clean this accessory.
Wipe up spilled brake or battery fluid at once as they may damage the surface.

HOW TO INSTALL THE REAR SEAT BAG

1. Install the rear seat bag as shown.

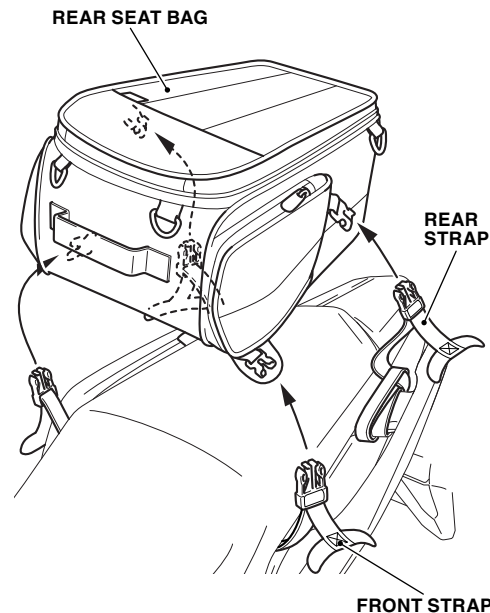

REAR SEAT BAG

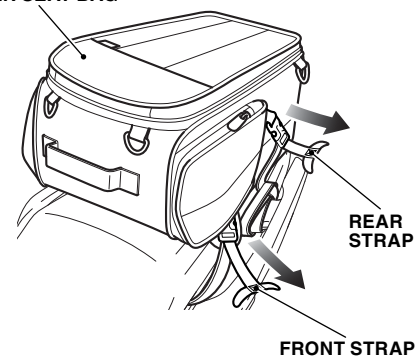

2. Tighten the straps while adjusting the balance between the right and left sides of the rear seat bag as shown.
 - Repeat on the right side.
 - Secure well by pulling the straps tight.

CB500X/XA

Genuine Accessory User's Guide

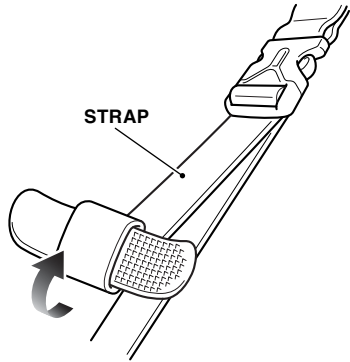

3. Wind the strap as shown.
4. Secure the strap end as shown.

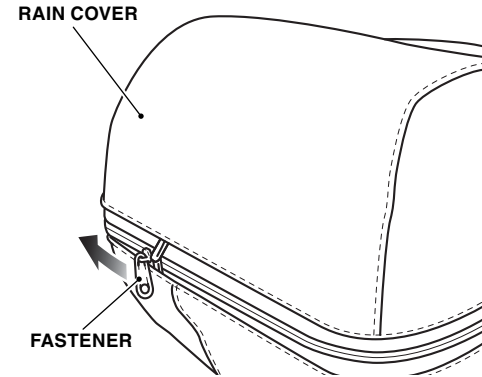
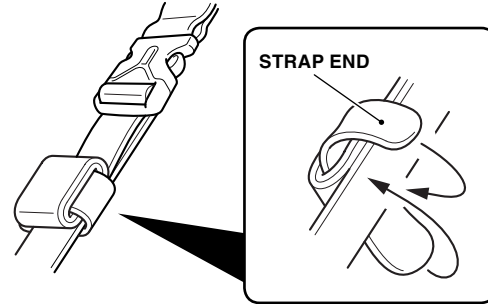

HOW TO USE THE RAIN COVER

1. Open the fastener as shown.
 - Perform this step on extended the rear seat bag.

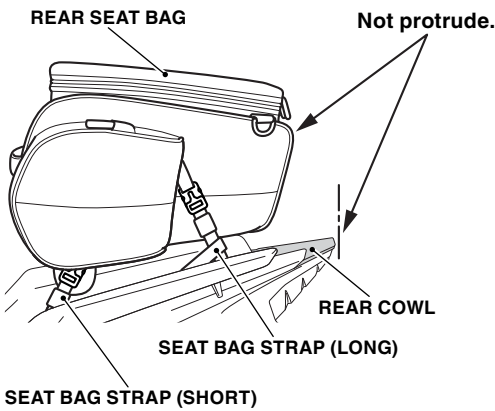

5. Secure the other straps in the same manner.
6. Make sure that the rear seat bag does not protrude to the rear of the tail light as shown.
 - If the rear seat bag protrudes, adjust the tensions of front strap and rear strap.

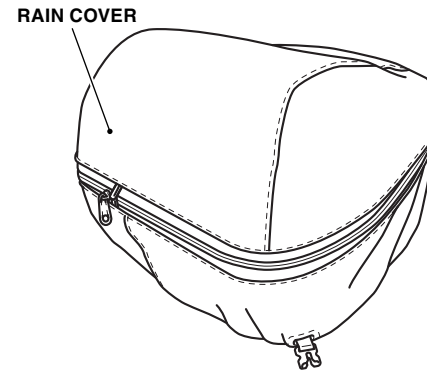

2. Temporarily release the buckles and pass them through the rain cover holes as shown.

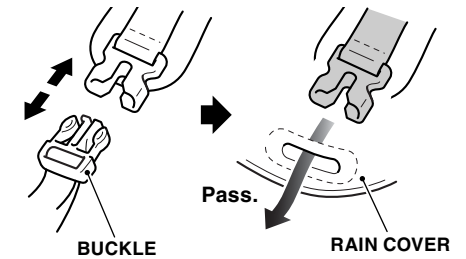

3. Cover the rain cover as shown.

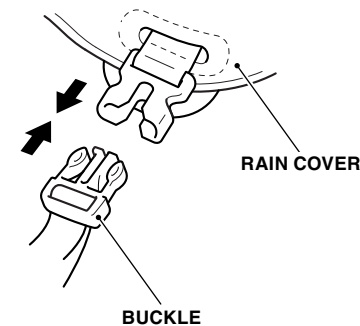

4. Lock the buckles as shown.

REAR TRUNK

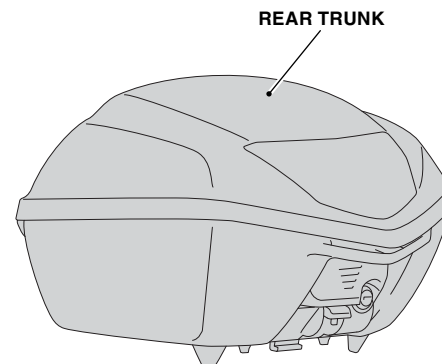

- The weight of the cargo must not exceed the following maximum weight capacity:
6.6 lb (3.0 kg)
 - Be sure that the rear trunk is installed securely before riding.
 - Before riding, confirm that lid is closed.
 - The rear trunk is not perfectly watertight, and water may enter when washing the motorcycle, when it rains, etc.
 - To prevent burns, allow the engine, exhaust system, radiator, etc., to cool before installing and removing the accessory.
 - Do not store valuables or fragile articles in the rear trunk.
 - Don't place a heavy object on the opened lid or apply an excessive force from the top of opened lid.
 - Open and close the lid gently.
 - If the rear trunk gets dirty, slightly push and clean it with a sponge or a shop towel moistened with a neutral detergent, remove the detergent with clean water, and then wipe them dry with a clean sponge or shop towel.
 - Never use organic solvents such as gasoline, thinner and benzine to clean this accessory. Also do not use acid or alkaline cleaners to clean this accessory.
- Wipe up spilled brake or battery fluid at once as they may damage the surface.

HOW TO USE THE EXTENDED REAR SEAT BAG

1. Open the fastener as shown.

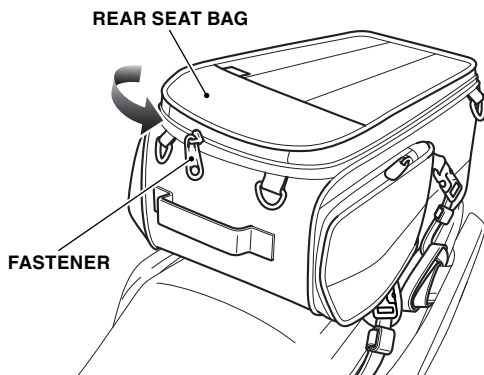

2. Pull up the rear seat bag as shown.

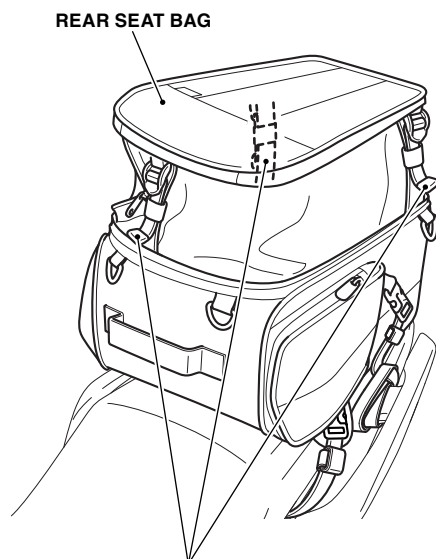

Firmly pull to secure the belts.

CB500X/XA

Genuine Accessory User's Guide

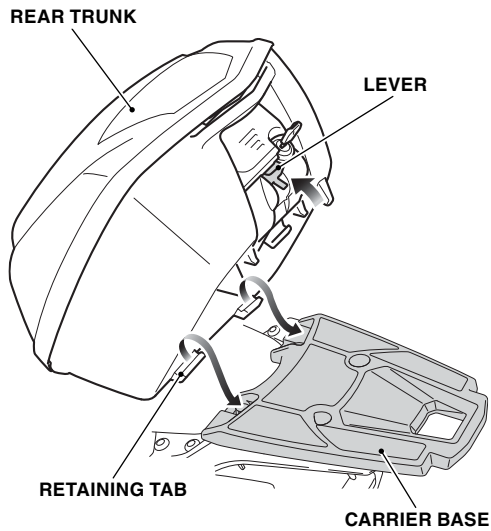

HOW TO INSTALL THE REAR TRUNK

1. Insert the key as shown and release the lock by turning the key clockwise.

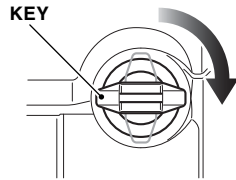

2. Install the retaining tabs of rear trunk into the carrier base with the lever in the raised position as shown.

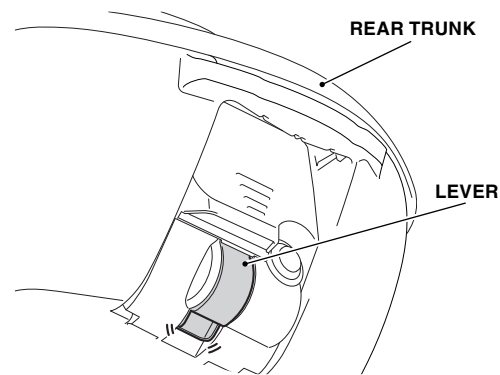

5. Lock the rear trunk by turning the key in the direction shown.

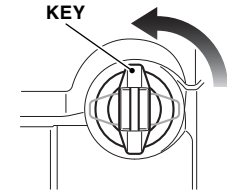

6. Remove the key, check the lever and rear trunk not to lift and install it securely.
 - The rear trunk come off during riding unless it is mounted securely.

HOW TO REMOVE THE REAR TRUNK

1. Remove the rear trunk in the reverse order of installation.

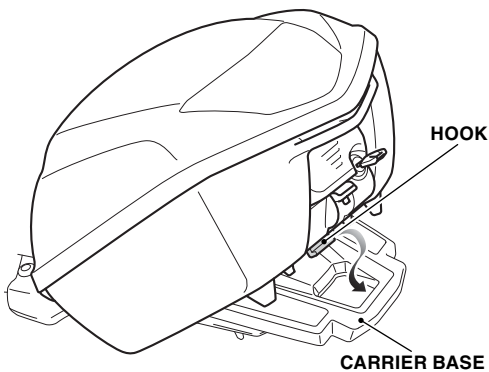

3. Position the hook with the hole of the carrier base as shown.
4. Secure the hook by pressing the lever down.

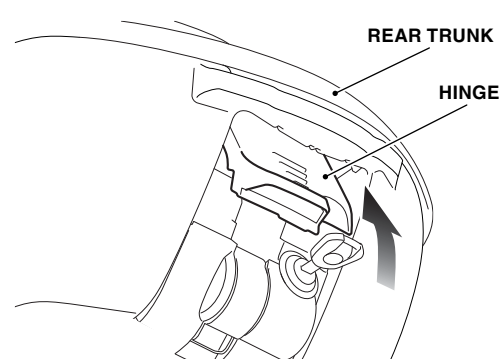
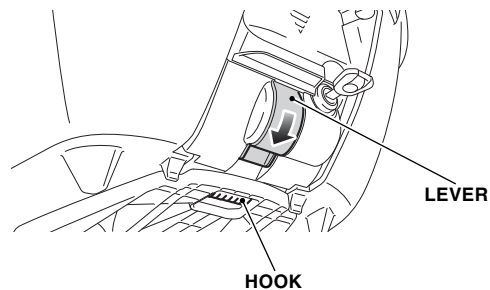

HOW TO OPEN THE REAR TRUNK

1. Release the lock by turning the key clockwise.

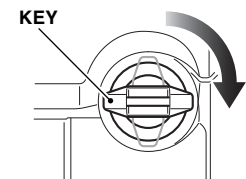

2. Pull the hinge up.

CB500X/XA

Genuine Accessory User's Guide

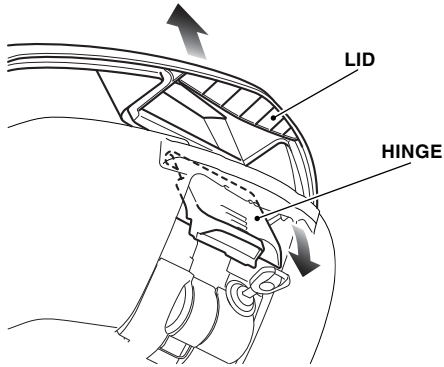

3. Raising the upper part of hinge, move the hinge down as shown and open the lid.

5. Remove the key.
 - Make sure the lid is locked down securely.

HOW TO CLOSE THE REAR TRUNK

1. Confirm that the key position is as shown.

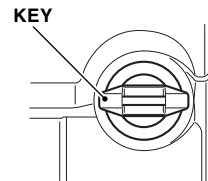

2. Close the lid.

HOW TO STORE THE REAR TRUNK INNER BAG

1. Open the rear trunk and store the rear trunk inner bag.
2. Close the rear trunk.
 - Be careful not to have the stored item pinched when the rear trunk is closed.

3. Holding the upper part of the hinge, push the hinge down.

4. Lock the rear trunk by turning the key in the direction shown.

- Be careful not to have the stored item pinched when the rear trunk is closed.

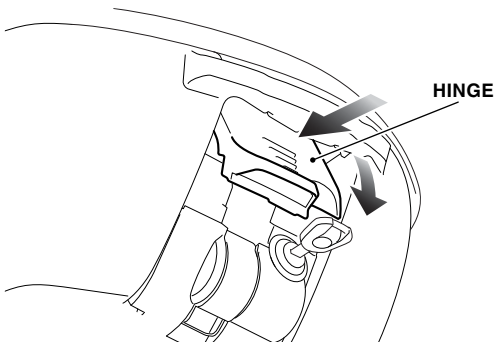
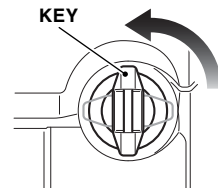

PANNIERS

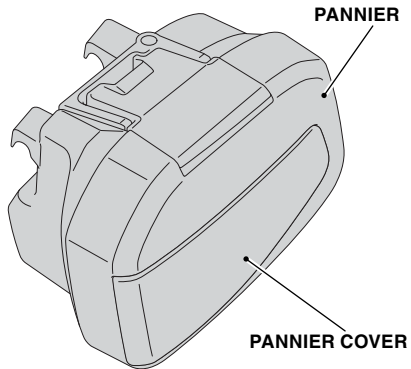

- The weight of the cargo must not exceed the following maximum weight capacity:
Each pannier 8.8 lb (4.0 kg)
 - Load weight equally on both sides to minimize imbalance. If the weight is not loaded equally on both sides or if it exceeds the maximum weight capacity of this accessory, handling is proportionally affected, resulting in serious accident or injury.
 - Do not store valuables or fragile articles in the panniers.
 - Be sure that the panniers are installed securely before riding.
 - Before riding, confirm that lid is closed.
 - To prevent burns, allow the engine, exhaust system, radiator, etc., to cool before installing and removing the accessory.
 - The pannier is hot while the engine is running and after it has been stopped (after riding etc.). Especially the lower part of the pannier on the right side is close to the muffler and thus becomes very hot, for that reason it should not be touched for some time.
 - The panniers are not perfectly watertight, and water may enter when washing the motorcycle, when it rains, etc.
 - Always install panniers on both the left and the right side.
 - Don't place a heavy object on the opened lid or apply an excessive force from the top of opened lid.
 - Open and close the lid gently.
 - If the pannier gets dirty, slightly push and clean it with a sponge or a shop towel moistened with a neutral detergent, remove the detergent with clean water, and then wipe them dry with a clean sponge or shop towel.
 - Never use organic solvents such as gasoline, thinner and benzine to clean this accessory. Also do not use acid or alkaline cleaners to clean this accessory.
- Wipe up spilled brake or battery fluid at once as they may damage the surface.

HOW TO INSTALL THE PANNIERS

1. Install the key. Release the lock by turning the key clockwise.

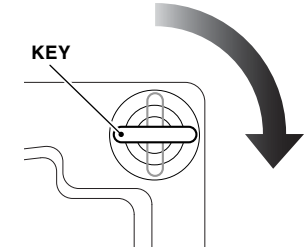

2. Install the pannier.
 - Install the pannier with this handle lever raised.
 - Insert into the hook.

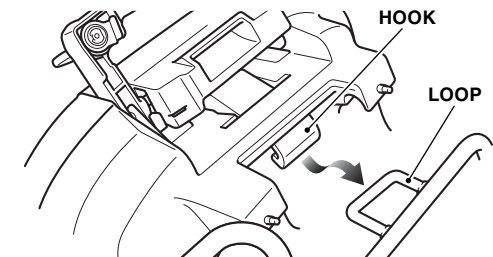
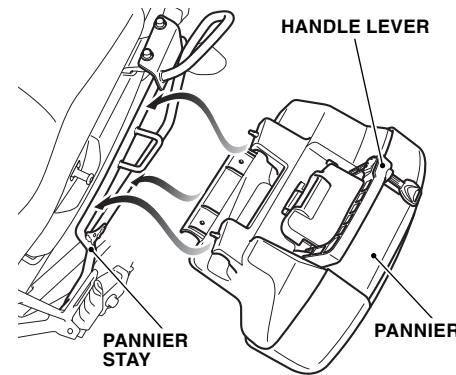

3. Lower the handle lever.

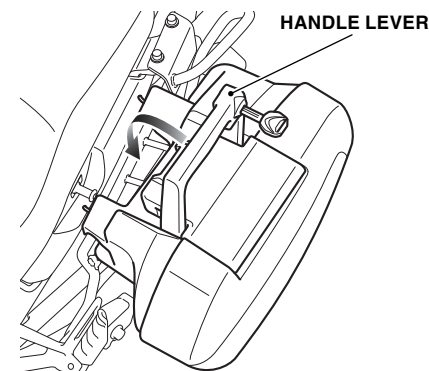

CB500X/XA

Genuine Accessory User's Guide

HANDLE LEVER

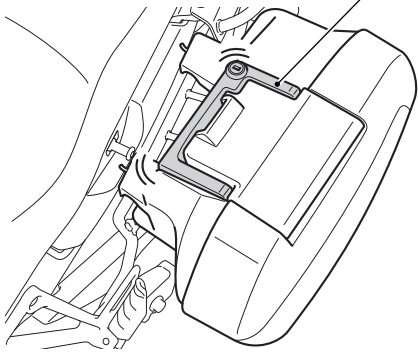

4. Lock the pannier by turning the key counterclockwise as shown.

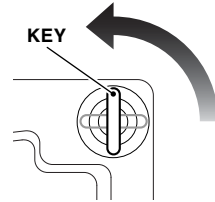

5. Remove the key. Be sure that the handle lever cannot be released and the left pannier is installed securely.
 - The pannier can come off during riding unless it is mounted securely.

3. Open the lid.

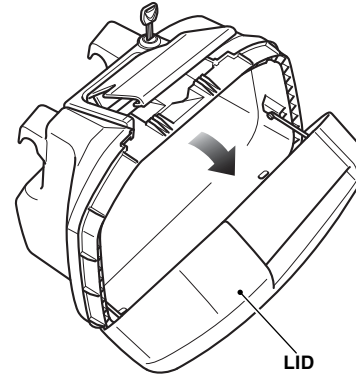

HOW TO REMOVE THE PANNIERS

1. Remove the panniers in the reverse order of installation.

HOW TO CLOSE THE PANNIERS

1. Close the panniers in reverse order of opening.
 - Be careful not to have the stored item pinched when the rear trunk is closed.

LID LOCK LEVER

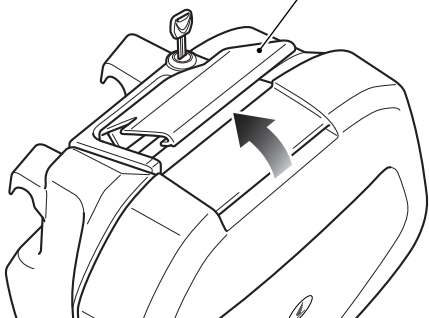

HOW TO OPEN THE PANNIERS

1. Install the key. Release the lock by turning the key clockwise.

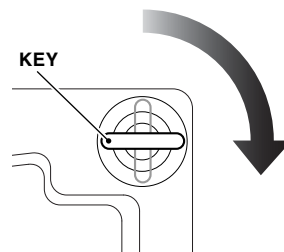

2. Lift the lid lock lever.

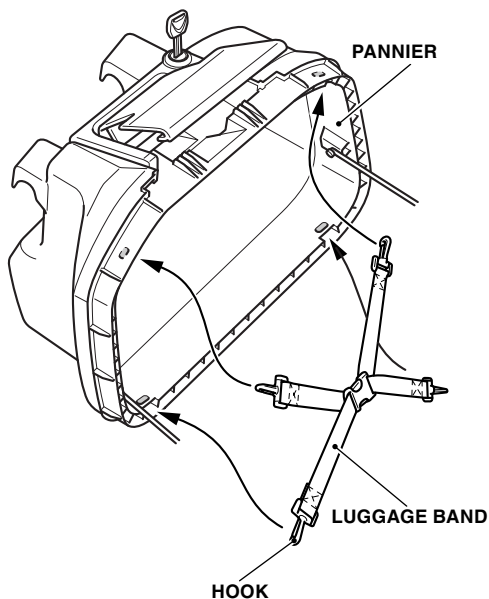

HOW TO INSTALL THE LUGGAGE BAND

1. Open the lid.
2. Install the luggage band as shown.
 - Secure the hooks to the shaded parts.

TANK BAG

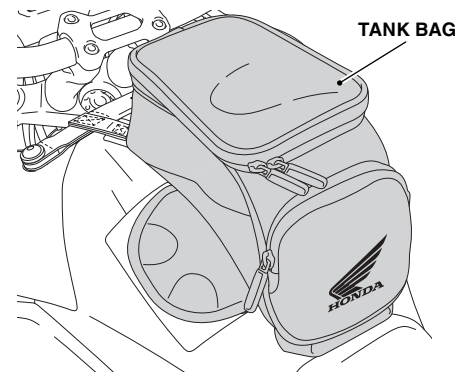

- The weight of the cargo must not exceed the following maximum weight capacity:
3.3 lb (1.5 kg)
 - Be sure that the tank bag is installed securely before riding.
 - Before riding, close the tank bag.
 - The tank bag is not perfectly watertight, and water may enter when it rains, etc.
 - Do not store valuables or fragile articles in the tank bag.
 - When washing the motorcycle and when leaving the motorcycle, remove the tank bag.
 - Before installation, remove all dust, sand, etc. from fuel tank and tank bag, as otherwise the fuel tank may be damaged.
 - Never use organic solvents such as gasoline, thinner and benzene to clean this accessory. Also do not use acid or alkaline cleaners to clean this accessory.
- Wipe up spilled brake or battery fluid at once as they may damage the surface.

HOW TO INSTALL THE TANK BAG

1. Lock the buckle as shown.
 - Repeat on the right side.

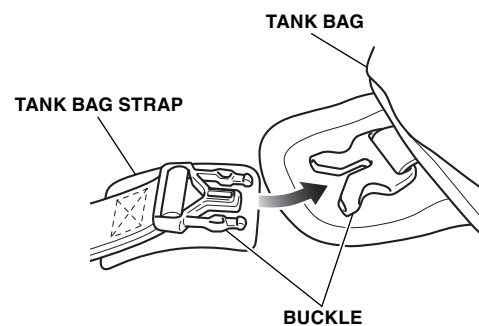

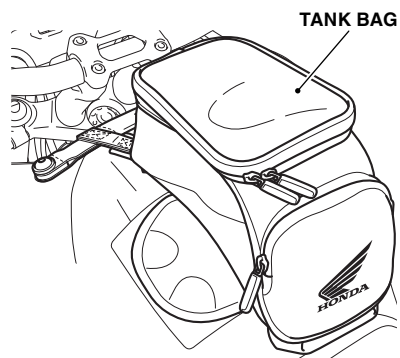

2. Install the tank bag as shown.

WHEEL STRIPE

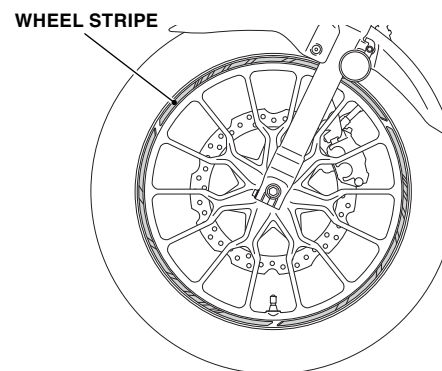

- When this accessory becomes dirty, rinse it thoroughly with cool water to remove loose dirt, then wipe with a clean cloth or sponge. Do not use a brush to clean this accessory as it may scratch the surface.
- Never use organic solvents such as gasoline, thinner and benzine to clean this accessory. Also do not use acid or alkaline cleaners to clean this accessory. Wipe up spilled brake or battery fluid at once as they may damage the surface.
- Do not wash the motorcycle with a high-pressure washer, as this may peel off the wheel stripes.

HOW TO USE THE TANK BAG COVER

1. Put the tank bag cover on the tank bag.

TANK PAD

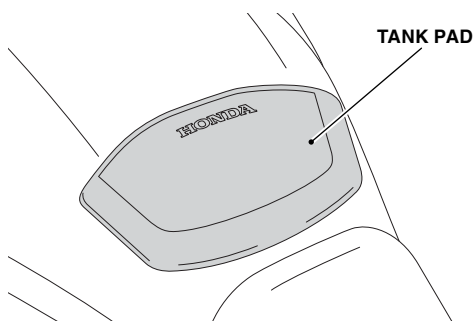

- When this accessory becomes dirty, rinse it thoroughly with cool water to remove loose dirt, then wipe with a clean cloth or sponge. Do not use a brush to clean this accessory as it may scratch the surface.
- Never use organic solvents such as gasoline, thinner and benzine to clean this accessory. Also do not use acid or alkaline cleaners to clean this accessory. Wipe up spilled brake or battery fluid at once as they may damage the surface.