

ACCESSORY SOCKET

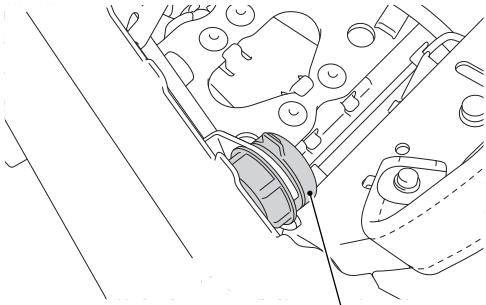

ACCESSORY SOCKET

- The maximum power rating of connected accessories is 36W (12V, 3A).
- Use accessories with engine running to avoid discharging the battery.
- Do not use a cigarette lighter, as this can cause a malfunction.
- Cover the socket with the cap when the accessory socket is not used to prevent entry of foreign objects.
- Carefully secure any connected devices, as vibrations may cause them to shift unexpectedly.
- Use a 3A fuse for replacement of the fuse. Do not use any other fuse for replacement.

<UNDER THE SEAT>

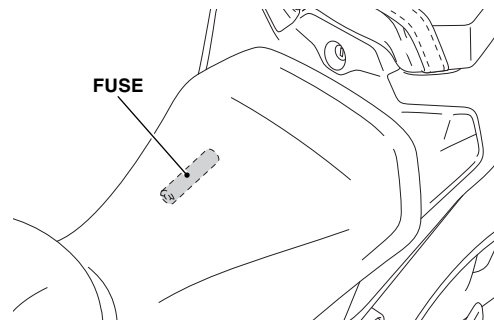

FUSE

CENTERSTAND

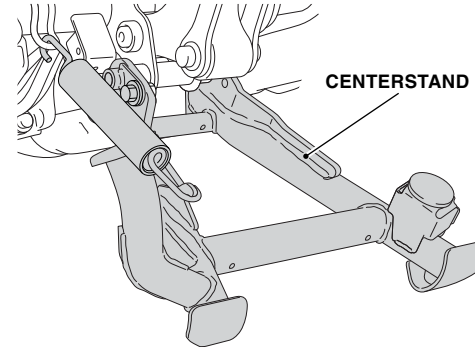

CENTERSTAND

- Before starting your motorcycle, check that the side stand and the centerstand are fully retracted.
- Always choose a flat ground when setting the center stand.

HOW TO USE THE CENTERSTAND

1. Park safely on a level ground and stop the engine.
2. Setting the centerstand.
 - **Let down the centerstand, stand on the left side of the motorcycle. Hold the left handle grip and the left assist grip. Press down on the tip of the stand with your right foot and, simultaneously, pull up and back.**

LEFT ASSIST GRIP

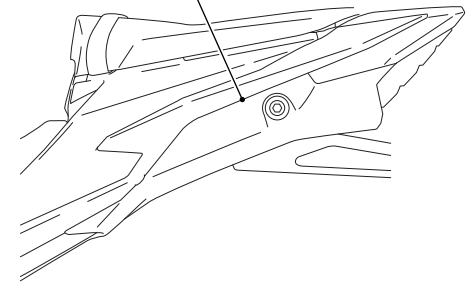

HEATED GRIPS

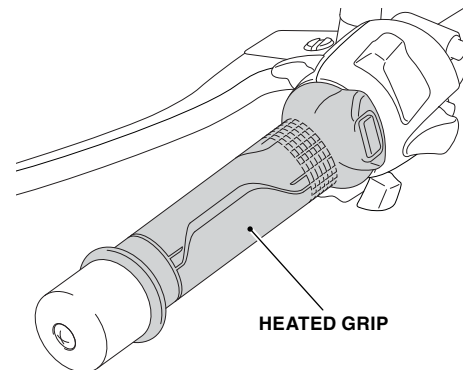

HEATED GRIP

HOW TO USE THE HEATED GRIP

- For operating instruction, refer to the heated grip kit owner's manual.

REAR CARRIER

for Canada

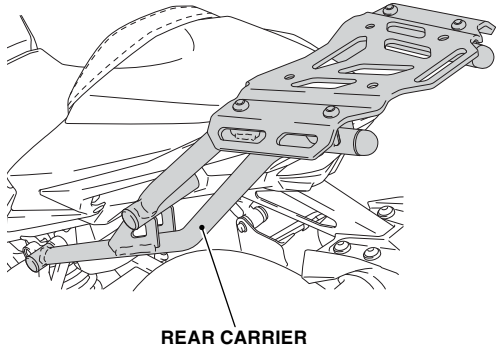

- The weight of the cargo must not exceed the following maximum load capacity:
11.0 lb (5.0 kg)
- When this accessory becomes dirty, rinse it thoroughly with cool water to remove loose dirt, then wipe with a clean cloth or sponge.
Do not use a brush to clean this accessory as it may scratch the surface.
- Never use organic solvents such as gasoline, thinner and benzine to clean this accessory. Also do not use acid or alkaline cleaners to clean this accessory.
Wipe up spilled brake or battery fluid at once as they may damage the surface.

REAR SEAT BAG

for Canada

REAR SEAT BAG

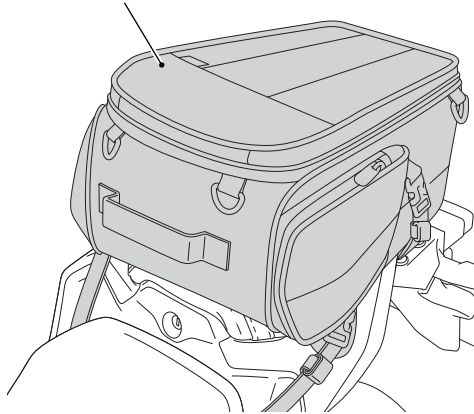

- The weight of the cargo must not exceed the following maximum weight capacity:
8.8 lb (4.0 kg)
- Be sure that the rear seat bag is installed securely before riding.
- Before riding, close the rear seat bag.
- The rear seat bag is not perfectly watertight, and water may enter when it rains, etc.
- Do not store valuables or fragile articles in the rear seat bag.
- To prevent burns, allow the engine, exhaust system, radiator, etc., to cool before installing and removing the accessory.
- When washing the motorcycle and when leaving the motorcycle, remove the rear seat bag.
- Do not let anybody ride on the rear seat bag and do not place luggage onto it.
- Never use organic solvents such as gasoline, thinner and benzine to clean this accessory. Also do not use acid or alkaline cleaners to clean this accessory.
Wipe up spilled brake or battery fluid at once as they may damage the surface.

REAR SEAT BAG

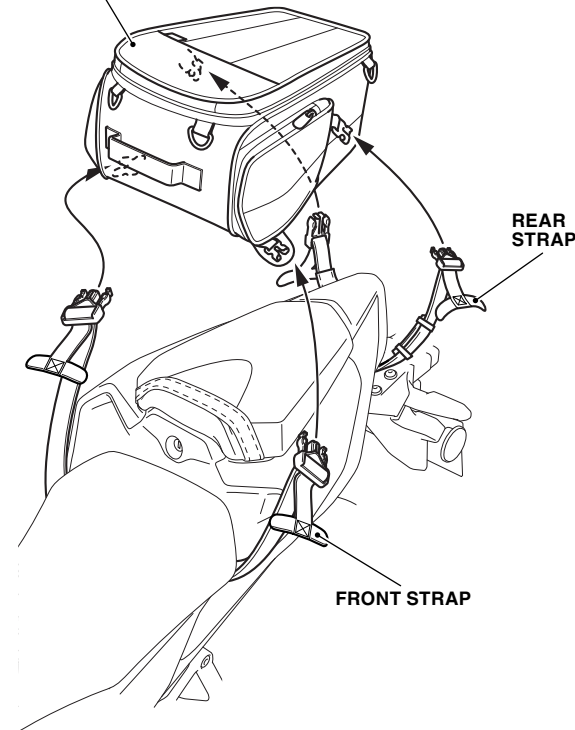

HOW TO INSTALL THE REAR SEAT BAG

1. Install the rear seat bag as shown.

REAR SEAT BAG

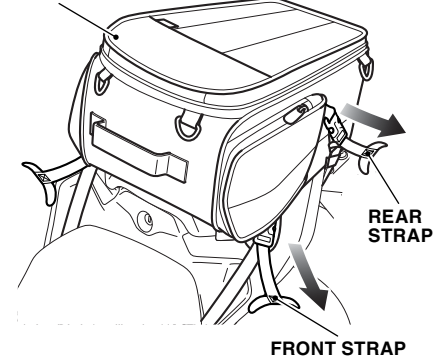

2. Tighten the straps while adjusting the balance between the right and left sides of the rear seat bag as shown.
 - Repeat on the right side.
 - Secure well by pulling the straps tight.

CB500F/FA

Genuine Accessory User's Guide

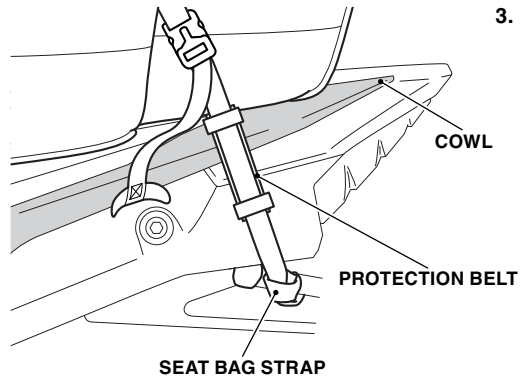

3. Attach the protection belt at a position that touching the cowl as shown.

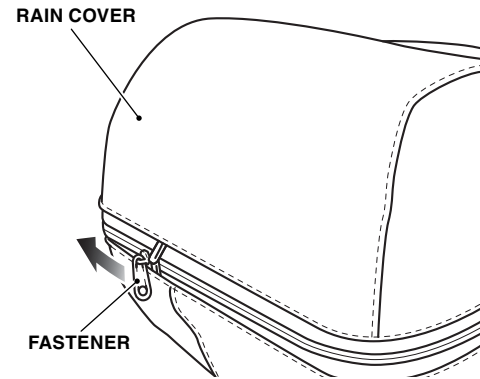

HOW TO USE THE RAIN COVER

1. Open the fastener as shown.
 - Perform this step on extended the rear seat bag.

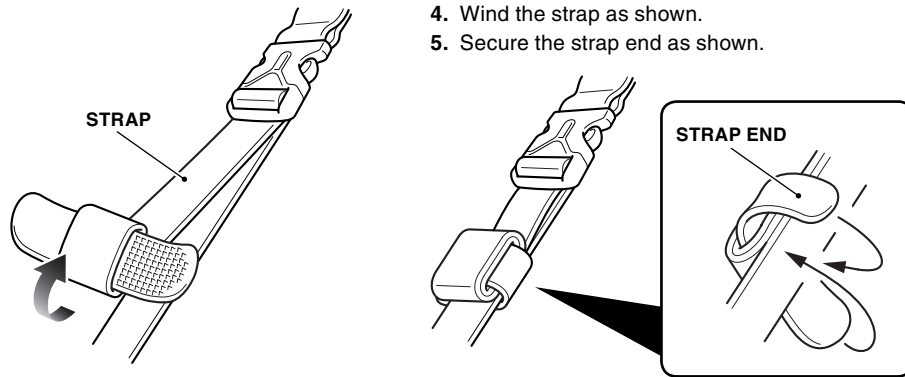

4. Wind the strap as shown.
5. Secure the strap end as shown.

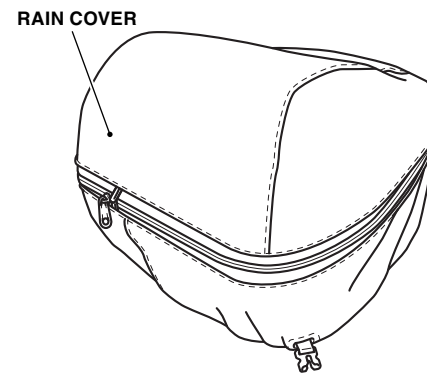

2. Temporarily release the buckles and pass them through the rain cover holes as shown.

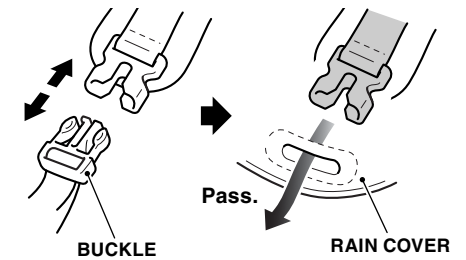

3. Cover the rain cover as shown.

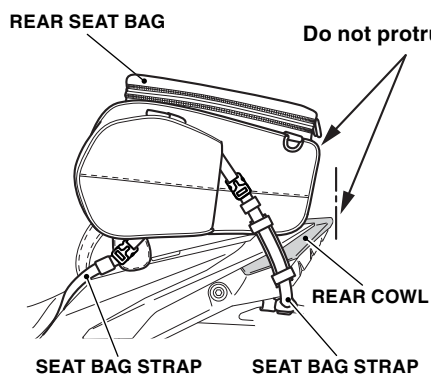

6. Secure the other straps in the same manner.
7. Make sure that the rear seat bag does not protrude to the rear of the tail light as shown.
 - If the rear seat bag protrudes, adjust the tensions of front strap and rear strap.

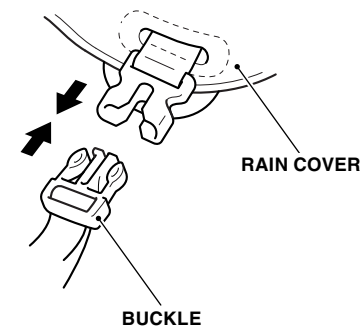

4. Lock the buckles as shown.

REAR TRUNK

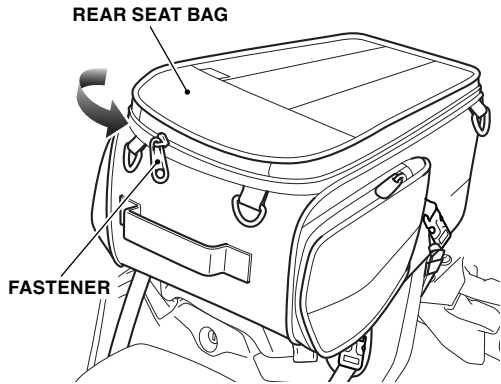

HOW TO USE THE EXTENDED REAR SEAT BAG

1. Open the fastener as shown.

REAR SEAT BAG



2. Pull up the rear seat bag as shown.

Firmly pull to secure the belts.

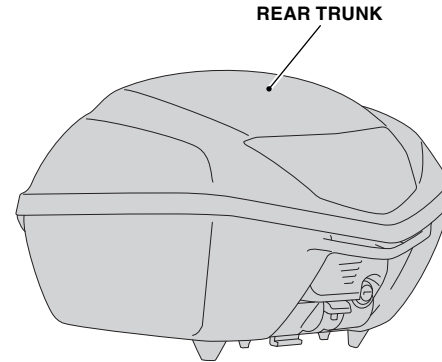

- The weight of the cargo must not exceed the following maximum weight capacity:
6.6 lb (3.0 kg)
 - Be sure that the rear trunk is installed securely before riding.
 - Before riding, confirm that lid is closed.
 - The rear trunk is not perfectly watertight, and water may enter when washing the motorcycle, when it rains, etc.
 - To prevent burns, allow the engine, exhaust system, radiator, etc., to cool before installing and removing the accessory.
 - Do not store valuables or fragile articles in the rear trunk.
 - Don't place a heavy object on the opened lid or apply an excessive force from the top of opened lid.
 - Open and close the lid gently.
 - If the rear trunk gets dirty, slightly push and clean it with a sponge or a shop towel moistened with a neutral detergent, remove the detergent with clean water, and then wipe them dry with a clean sponge or shop towel.
 - Never use organic solvents such as gasoline, thinner and benzine to clean this accessory. Also do not use acid or alkaline cleaners to clean this accessory.
- Wipe up spilled brake or battery fluid at once as they may damage the surface.

CB500F/FA

Genuine Accessory User's Guide

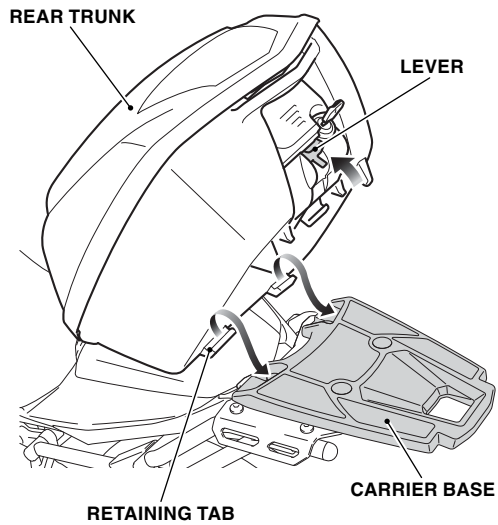

HOW TO INSTALL THE REAR TRUNK

1. Insert the key as shown and release the lock by turning the key clockwise.

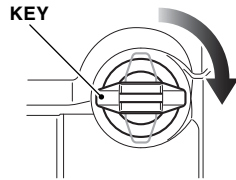

2. Install the retaining tabs of rear trunk into the carrier base with the lever in the raised position as shown.

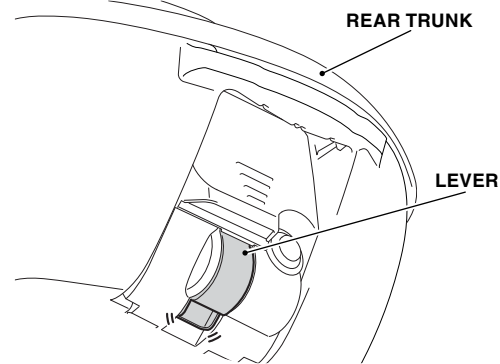

5. Lock the rear trunk by turning the key in the direction shown.

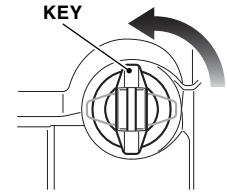

6. Remove the key, check the lever and rear trunk not to lift and install it securely.
• **The rear trunk come off during riding unless it is mounted securely.**

HOW TO REMOVE THE REAR TRUNK

1. Remove the rear trunk in the reverse order of installation.

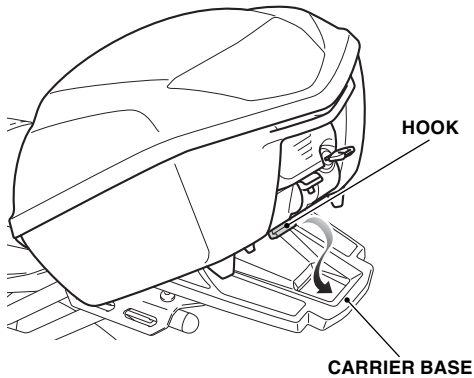

3. Position the hook with the hole of the carrier base as shown.

4. Secure the hook by pressing the lever down.

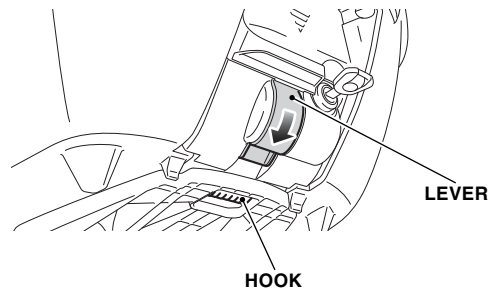

HOW TO OPEN THE REAR TRUNK

1. Release the lock by turning the key clockwise.

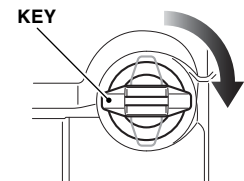
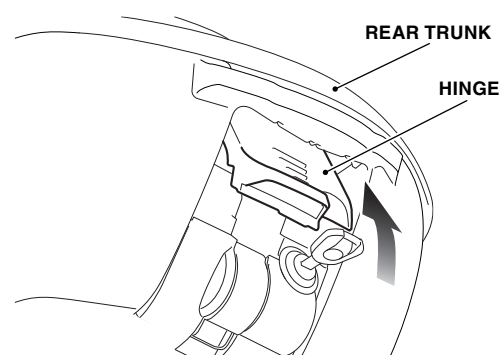

2. Pull the hinge up.

CB500F/FA

Genuine Accessory User's Guide

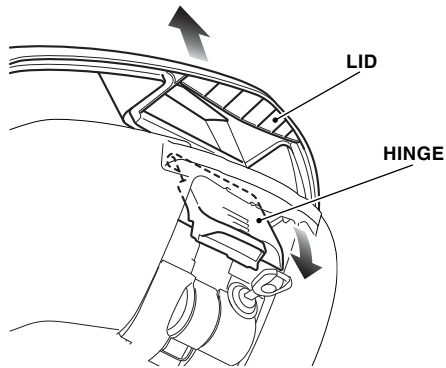

3. Raising the upper part of hinge, move the hinge down as shown and open the lid.

5. Remove the key.
 - Make sure the lid is locked down securely.

HOW TO CLOSE THE REAR TRUNK

1. Confirm that the key position is as shown.

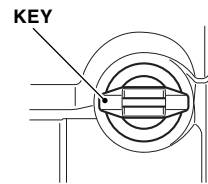

2. Close the lid.

HOW TO STORE THE REAR TRUNK INNER BAG

1. Open the rear trunk and store the rear trunk inner bag.
2. Close the rear trunk.
 - Be careful not to have the stored item pinched when the rear trunk is closed.

3. Holding the upper part of the hinge, push the hinge down.

4. Lock the rear trunk by turning the key in the direction shown.

- Be careful not to have the stored item pinched when the rear trunk is closed.

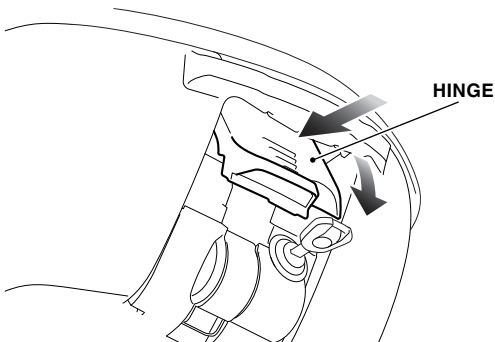
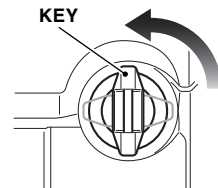

SEAT COWL

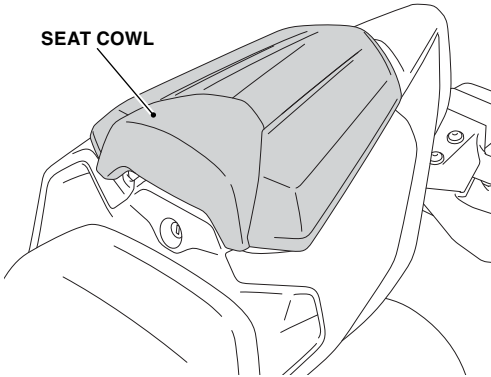

- Do not allow passengers to ride on the seat cowl.
 - Do not attach luggage to the seat cowl.
 - When this accessory becomes dirty, rinse it thoroughly with cool water to remove loose dirt, then wipe with a clean cloth or sponge. Do not use a brush to clean this accessory as it may scratch the surface.
 - Never use organic solvents such as gasoline, thinner and benzine to clean this accessory. Also do not use acid or alkaline cleaners to clean this accessory.
- Wipe up spilled brake or battery fluid at once as they may damage the surface.

TANK BAG

for USA

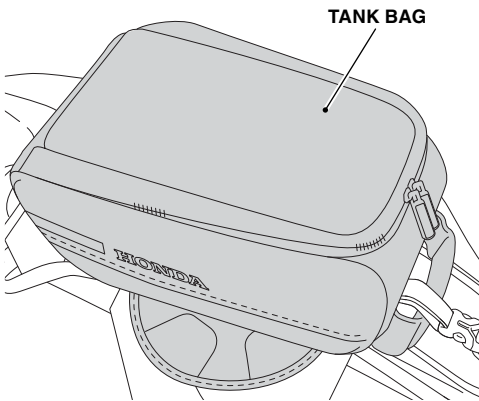

- The weight of the cargo must not exceed the following maximum weight capacity:
2.2 lb (1.0 kg)
 - Be sure that the tank bag is installed securely before riding.
 - Before riding, close the tank bag.
 - The tank bag is not perfectly watertight, and water may enter when it rains, etc.
 - Do not store valuables or fragile articles in the tank bag.
 - When washing the motorcycle and when leaving the motorcycle, remove the tank bag.
 - Before installation, remove all dust, sand, etc. from fuel tank and tank bag, as otherwise the fuel tank may be damaged.
 - Never use organic solvents such as gasoline, thinner and benzine to clean this accessory. Also do not use acid or alkaline cleaners to clean this accessory.
- Wipe up spilled brake or battery fluid at once as they may damage the surface.

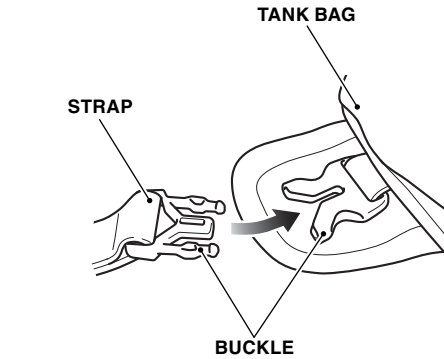

HOW TO INSTALL THE TANK BAG

1. Lock the buckle as shown.
 - Repeat on the right side.

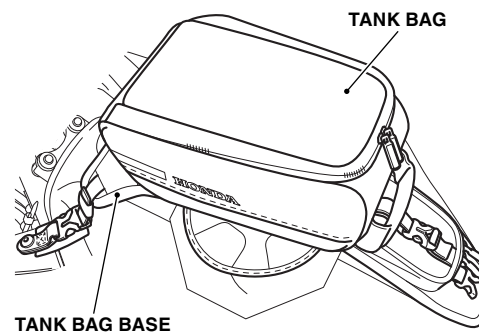

2. Install the tank bag as shown.

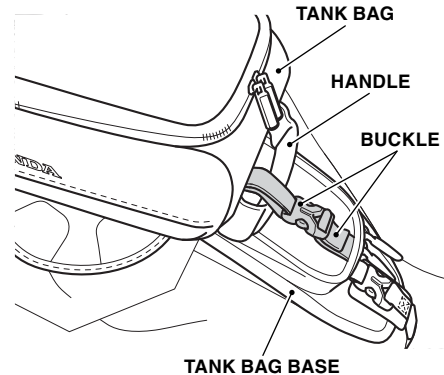

3. Disengage the buckles once and secure the handle of the tank bag as shown.

RAIN COVER

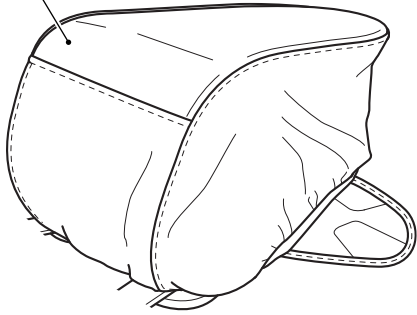

HOW TO USE THE RAIN COVER

1. Put the rain cover on the tank bag as shown.

TANK PAD

for USA

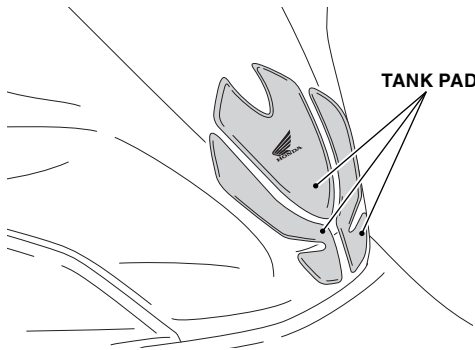

- When this accessory becomes dirty, rinse it thoroughly with cool water to remove loose dirt, then wipe with a clean cloth or sponge. Do not use a brush to clean this accessory as it may scratch the surface.
- Never use organic solvents such as gasoline, thinner and benzene to clean this accessory. Also do not use acid or alkaline cleaners to clean this accessory. Wipe up spilled brake or battery fluid at once as they may damage the surface.

WHEEL STRIPE

for USA

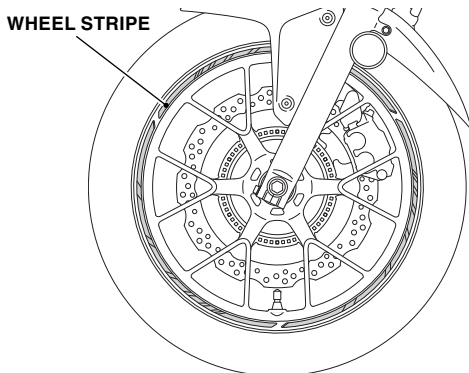

- When this accessory becomes dirty, rinse it thoroughly with cool water to remove loose dirt, then wipe with a clean cloth or sponge. Do not use a brush to clean this accessory as it may scratch the surface.
- Never use organic solvents such as gasoline, thinner and benzene to clean this accessory. Also do not use acid or alkaline cleaners to clean this accessory. Wipe up spilled brake or battery fluid at once as they may damage the surface.
- Do not wash the motorcycle with a high-pressure washer, as this may peel off the wheel stripes.

WIND VISOR

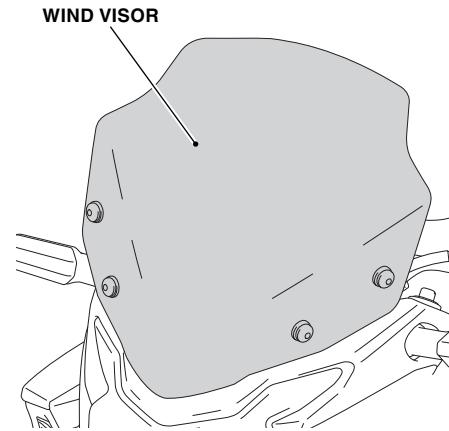

- Reduce speed when running in strong wind.
- Replace this accessory with a new one if it is damaged or discolored excessively.
- When this accessory becomes dirty, rinse it thoroughly with cool water to remove loose dirt, then wipe with a clean cloth or sponge. Do not use a brush to clean this accessory as it may scratch the surface.
- Never use organic solvents such as gasoline, thinner and benzene to clean this accessory. Also do not use acid or alkaline cleaners to clean this accessory. Wipe up spilled brake or battery fluid at once as they may damage the surface.
- If the motorcycle is left covered for an extended period of time, park in the shade. Parking a covered motorcycle in direct sunlight can cause the wind visor to deform due to heat buildup under the cover.
- Handle this accessory with care. It can be damaged when it is bent excessively or is subject to strong shock or impact.
- Select a firm, level surface when you park the motorcycle. Also bear in mind that strong wind can cause the motorcycle to topple to the ground.