



# INSTALLATION INSTRUCTIONS

Accessory

DUAL SPORT SADDLE BAG  
P/N 0SH55-KRH-A00

Application

XR150L  
CRF300L/LA/LD  
CRF300LR/LRA

Publication No.

MII 55132

Issue Date

October 2023

**Honda Dealer: Please give a copy of these instructions to your customer.**

## PARTS LIST

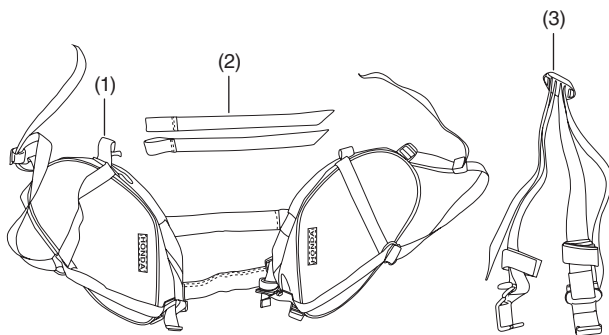

No.	Description	Qty.
(1)	Saddle bag set (R & L)	1
(2)	Loop straps	2
(3)	Tension mounting strap (not for use on XR150 application)	1

## USE AND CARE INFORMATION

- The weight of the cargo must not exceed 10 lbs.
- Clean the motorcycle before installing bags to avoid trapping dirt and dust between side covers and the saddle bags.
- Clean both sides of the contact area between the bag and the motorcycle frequently to avoid abrasions on the motorcycle body.
- Clean the bags with warm soapy water and a sponge or soft brush and let air dry. Do not use in a washing machine or dryer.
- Check straps periodically and retighten as needed.
- Make sure there are no loose strap ends that could become entangled with moving parts of the motorcycle.
- Make sure to keep the bags away from exhaust or any hot parts on the vehicle.

## XR150L INSTALLATION

1. Place the saddle bags over the seat. Adjust the height of both sides of the saddle bags and make sure the connecting velcro straps are fully engaged with each other. The final position of the saddle bags should match the pictures in order to keep them away from hot or moving parts.

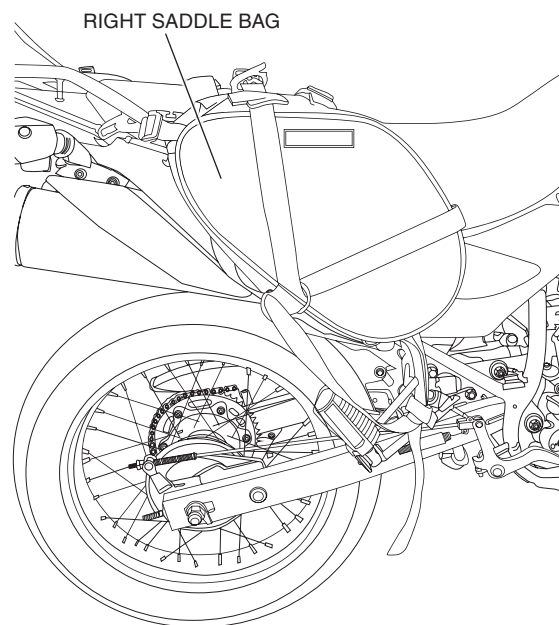
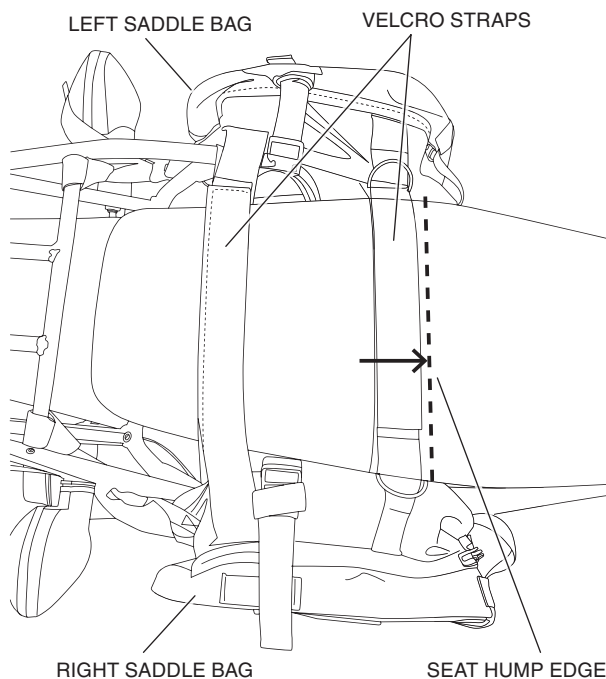

2. Locate one of the loop straps. On the right side of the unit, route the free end through the rack and then through the loop end of the loop strap, securing it to the right-side front corner of the rack as shown in the pictures below. Pull the end of the loop strap tight then route the free end through the rack.

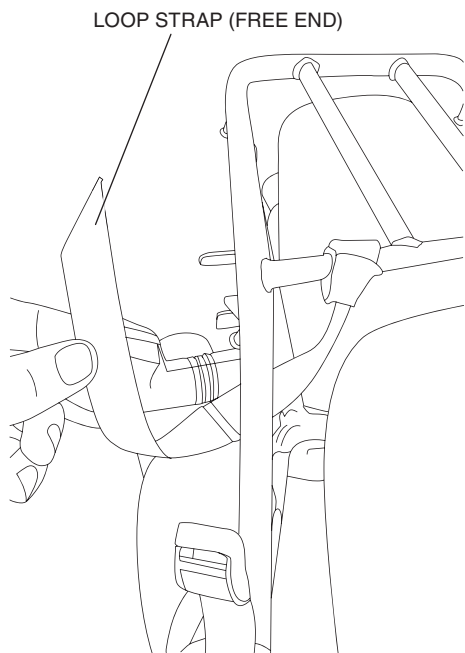
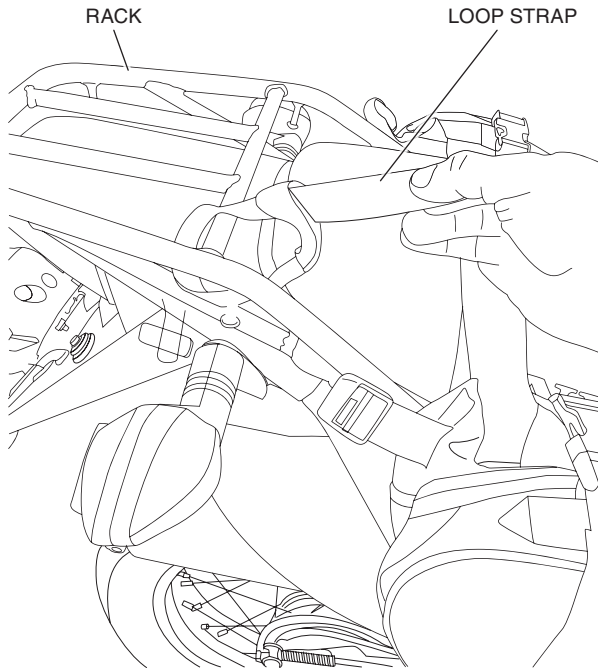

3. Locate the tension buckle on the back side of the saddle bag and weave the loop strap through the two slots in the tension buckle and pull it away from the saddle bag to tighten. Repeat steps 2 and 3 on the left side.

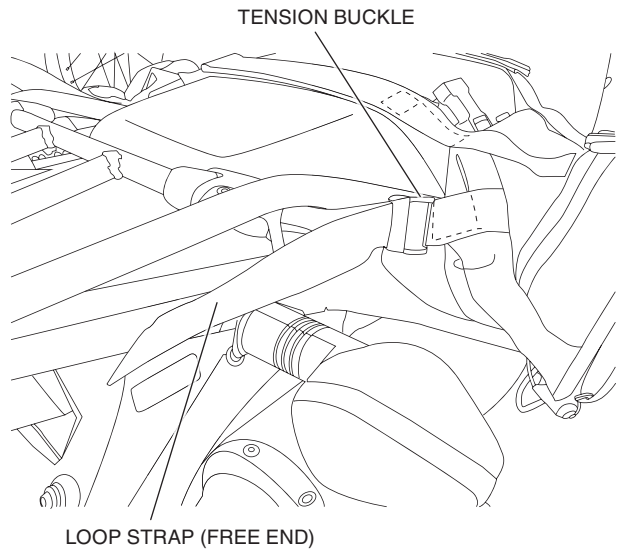
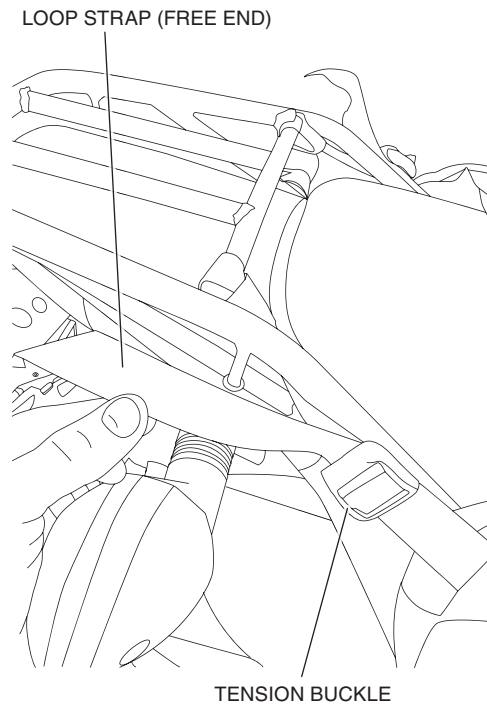

- To secure the right-side front part of the saddle bag, locate the long strap that is sewn onto the bag and route it through the lower D-ring as shown below.

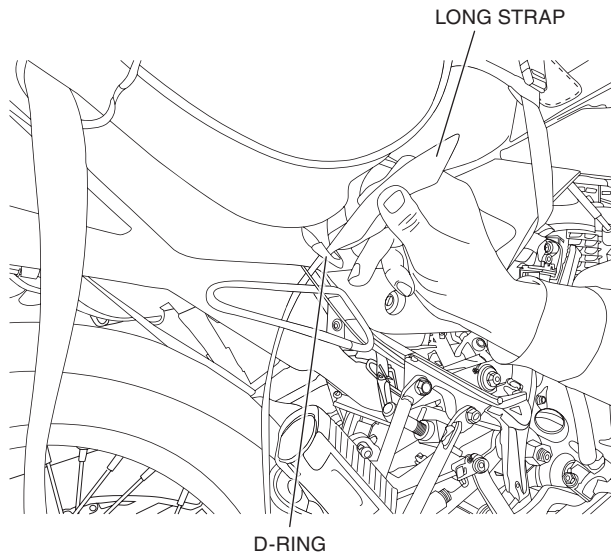

- Route the long strap through the passenger foot peg bracket as shown below.

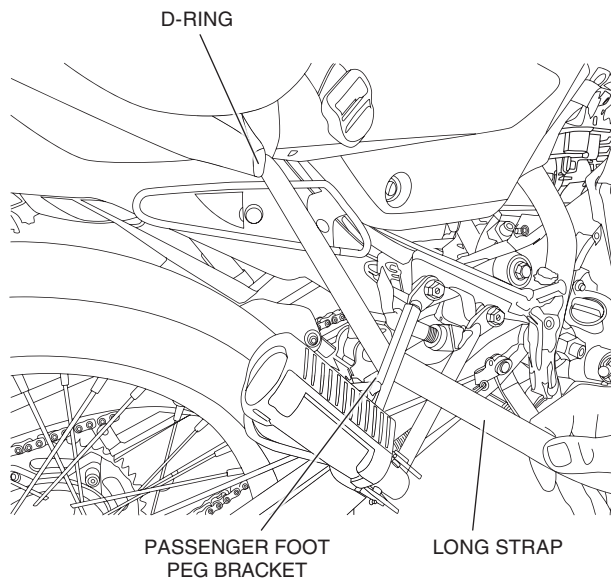

- Weave the end of the long strap through the tension buckle and tighten by pulling the long strap end away from the bag. Repeat steps 4, 5 and 6 for the left side bag.

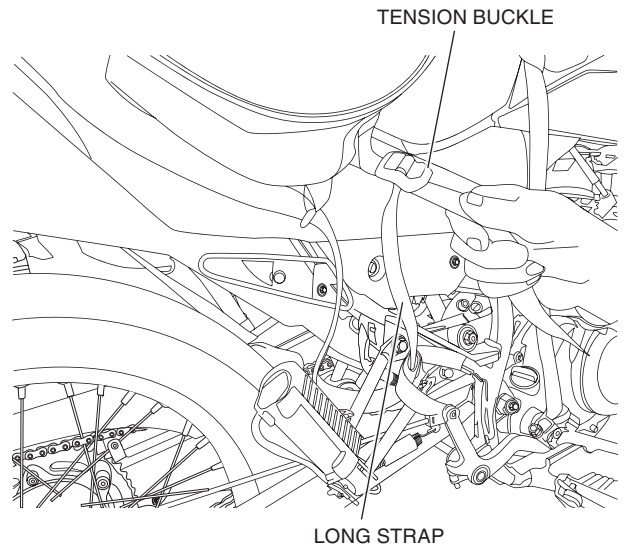

- Looking at the top view, adjust the saddle bags' position so the front-most velcro straps are no further forward than the seat hump edge.

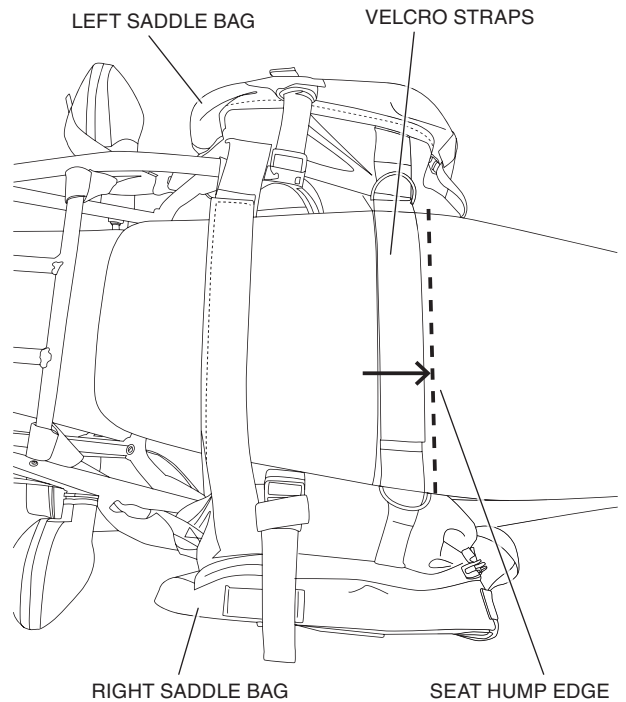

8. Looking at the right side view, adjust the saddle bags' position such that the lower edge of the bag is at least 10 mm from the side cover edge. Repeat for left side.

**\* Make sure to keep the bags away from exhaust or any hot parts on the unit.**

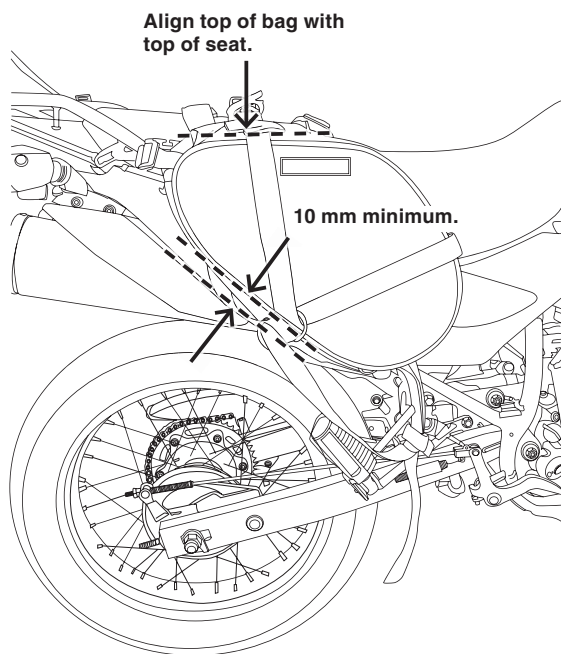

9. After the saddle bags are in position, roll up the extra strap length and secure the rolled strap using the velcro band as shown in the picture below.

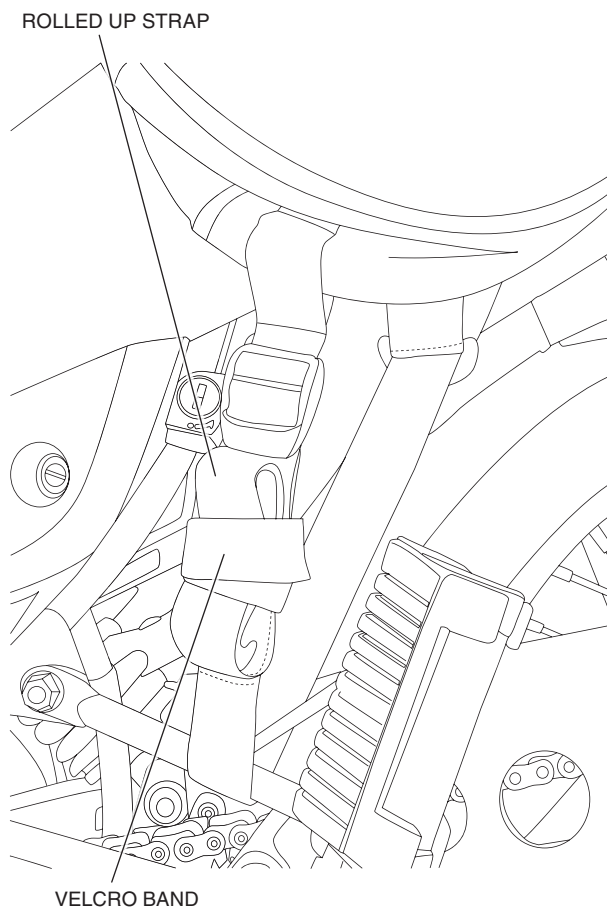

## CRF300L/LA/LD AND CRF300LR/LRA RALLY INSTALLATION

1. Place the saddle bags over the seat. Adjust the height of both sides of the saddle bags and make sure the connecting velcro straps are fully engaged with each other. The final position of the bags should match the pictures in order to keep them away from hot or moving parts.

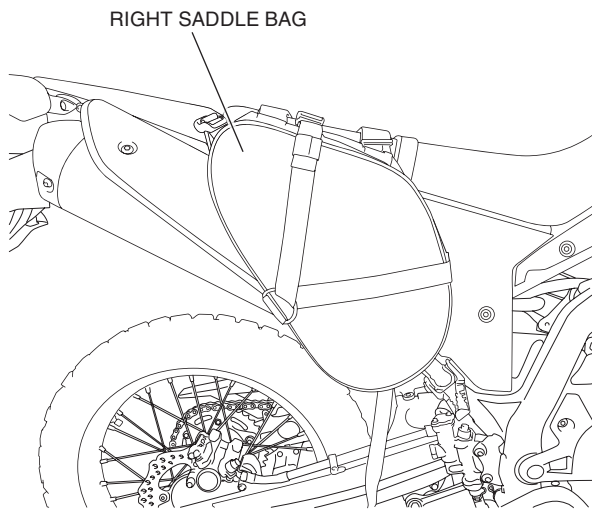
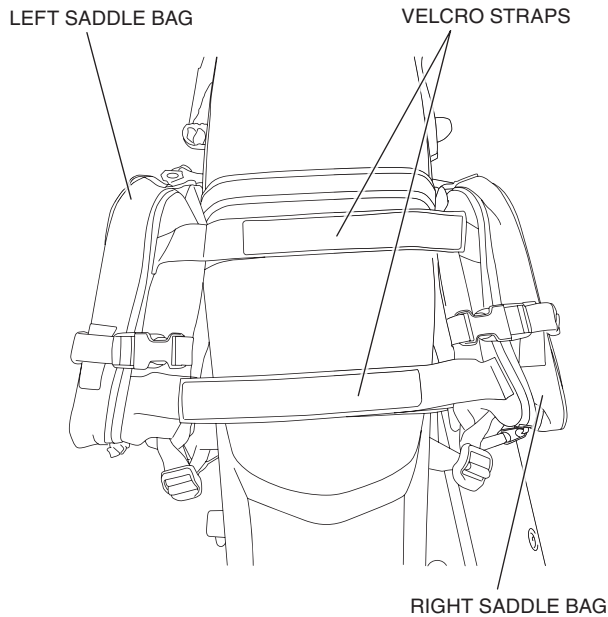

2. Locate one of the loop straps. On the left saddle bag, route the flat end of the loop strap through the two holes in the tension buckle. Then, repeat this process on the right saddle bag.

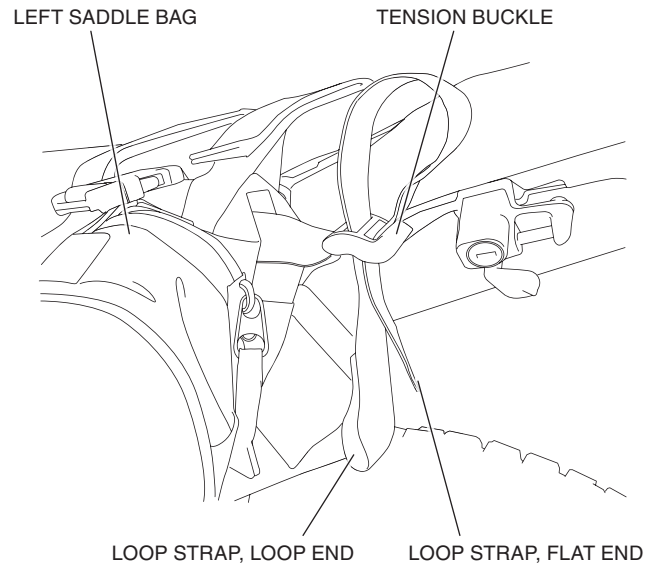

3. Route the loop ends of the loop straps to the opposite sides of the unit and hook the loops onto the cargo hooks. Do not tighten the loop straps (done in a later step).

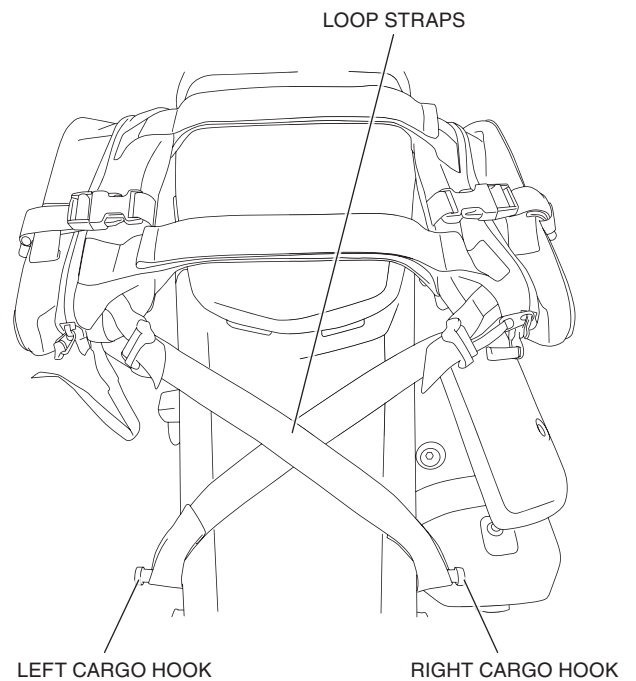

- On the right saddle bag, locate the velcro band, long strap, and lower D-ring (long strap and lower D-ring are sewn onto the saddle bag). Route the long strap through the lower D-ring and then install the velcro band onto the long strap.

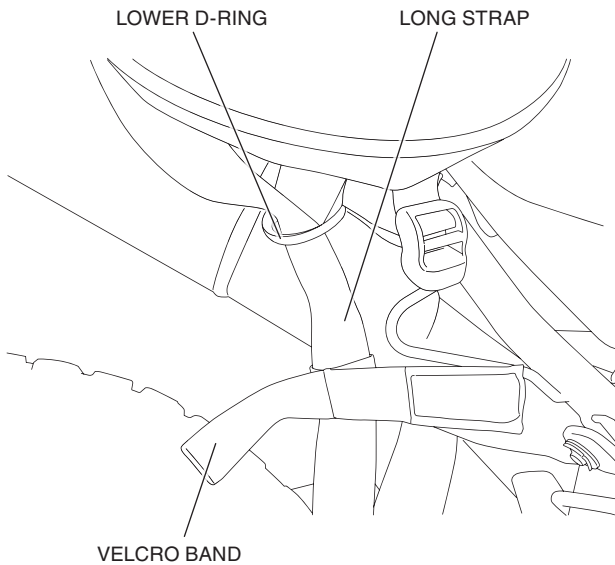

- Route the long strap upwards through the wire frame loop and then route the long strap through the tension buckle that is on the saddle bag next to the lower D-ring. Pull the long strap away from the saddle bag to tighten.

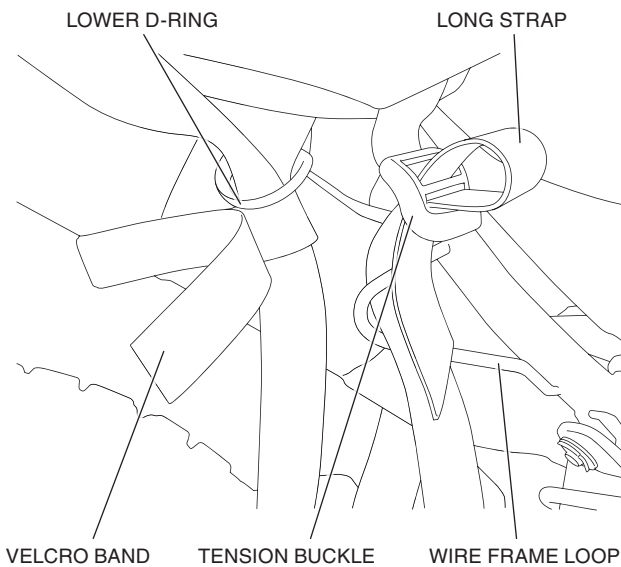

- On the left saddle bag, again locate the velcro band, long strap, and lower D-ring. Set the velcro band aside for step 7. Route the long strap through the lower D-ring, and then around the frame of the unit, behind the left step.

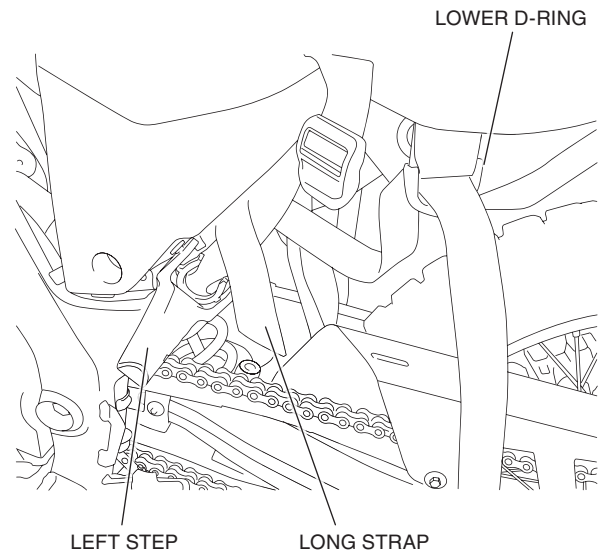

- Install the velcro band onto the long strap and then route the long strap through the tension buckle that is on the bag next to the lower D-ring. Pull the long strap away from the unit to tighten.

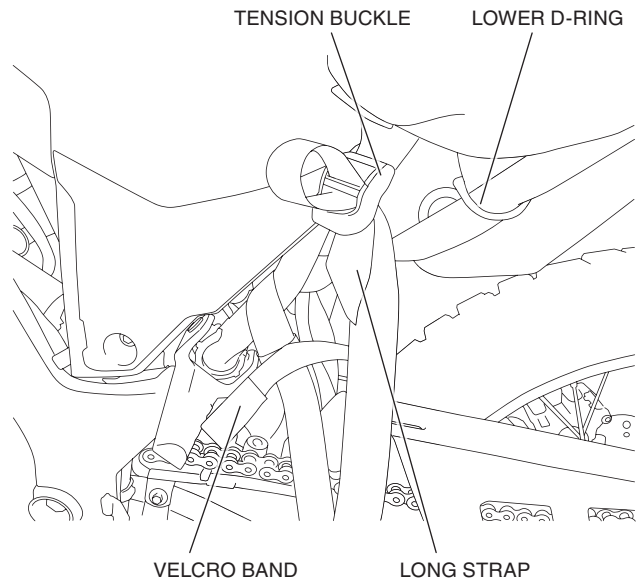

8. Tighten the two loop straps installed in steps 2 and 3 and the two long straps on the saddle bags. Make adjustments as necessary in order to keep the saddle bags and straps away from hot and moving parts. It may be necessary to adjust the velcro straps that hold the saddle bags together, shown in step 1.

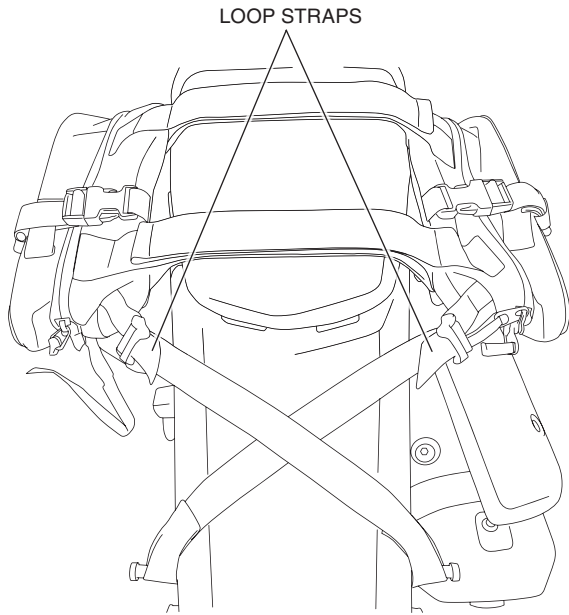

**<Left saddle bag>**

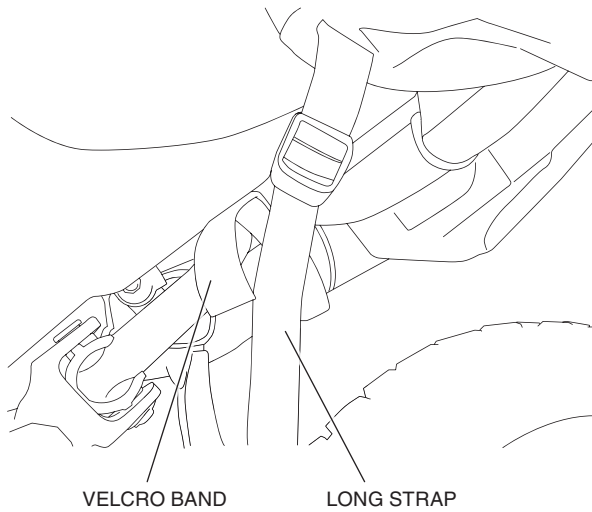

**<Right saddle bag>**

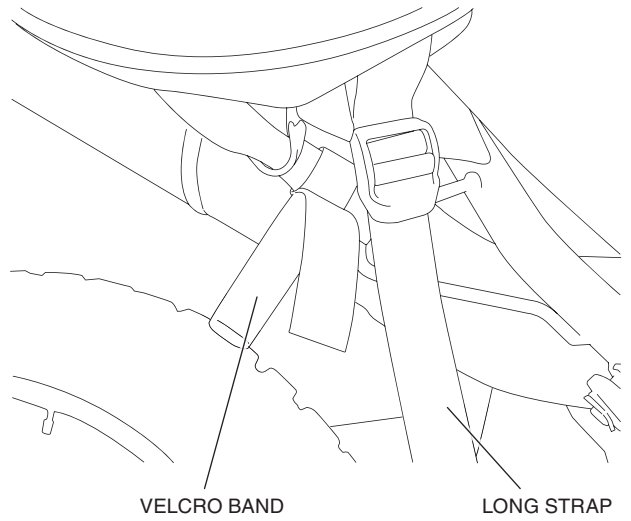

9. After the saddle bags are in position, roll up the excess long strap on each saddle bag and secure the rolled strap using the velcro band.

**<Left saddle bag>**

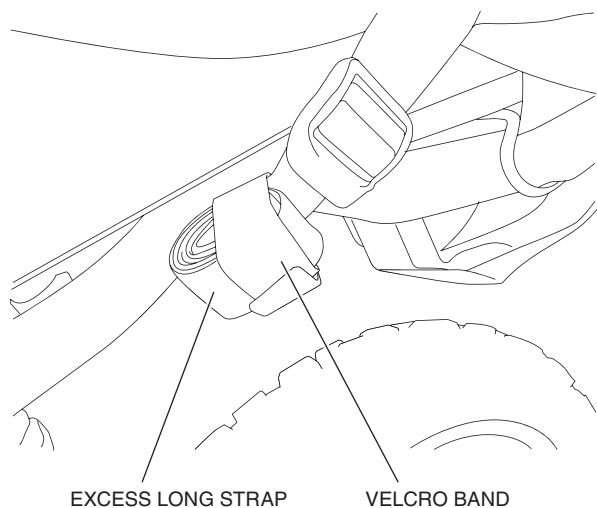

**<Right saddle bag>**

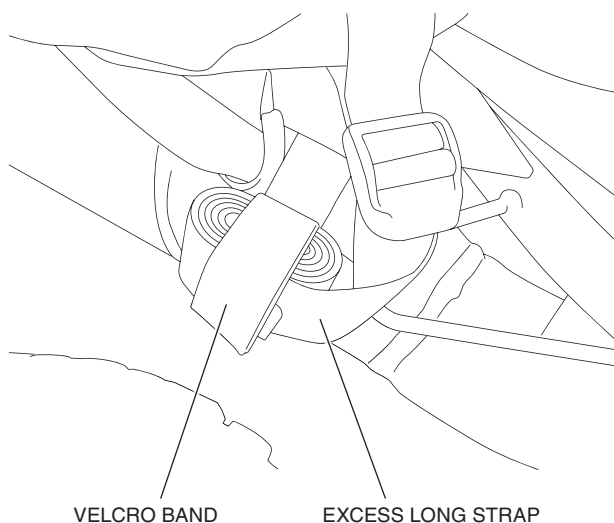

**NOTE: Before you ride, make sure all excess length of strap is well-secured and away from any moving parts.**

## INSTRUCTIONS FOR USE OF OPTIONAL VINYL FILM TEMPLATES

For added protection of motorcycle body surfaces, Honda offers sheets of vinyl film that can be purchased separately and cut to fit your unit using the template attached below.

The product below contains one sheet. **For the XR150L application, one sheet is required. For the CRF300L and CRF300LR application, two sheets are required.** They can be ordered separately from American Honda.

### PROTECTOR SEAL 08P70-MGE-D20

#### TEMPLATE DIRECTIONS (XR150L ONLY)

1. Print out the templates at the end of these instructions. Make sure the printed template size is correct by confirming the actual length measurement on the scale legend shown. Once size is confirmed correct, use a pair of scissors to cut out the paper templates.
2. Place a sheet of the protector seal vinyl film on the table/work area with the shiny side up ("3M" logo facing down). Place the right side paper template on top of the vinyl film with "RIGHT SIDE COVER" label facing up. Using a black marker, trace the paper template shape onto the vinyl film. Once complete, cut out the template shape on the vinyl film.



- Before removing the backing, dry fit the vinyl film template onto the unit's side cover by aligning as shown in the pictures below. It may be helpful to use small pieces of tape to hold the template in place while fine tuning the intended alignment. Locate the narrow triangular cutout in the template. This cutout accounts for curvature in the side cover and should be closed (edges touching) by the end of the installation process. When ready, remove the adhesive backing protection from the vinyl film and affix the vinyl film to the side cover.

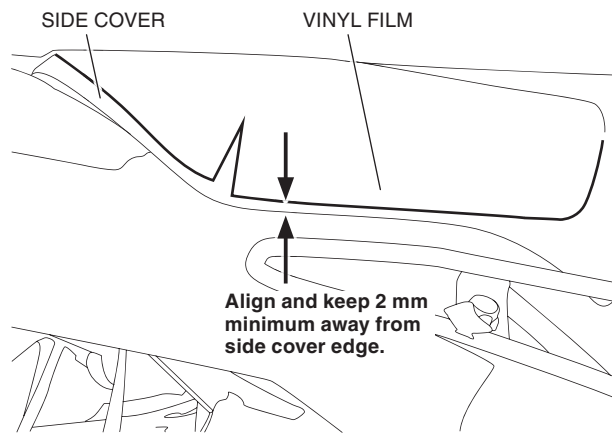
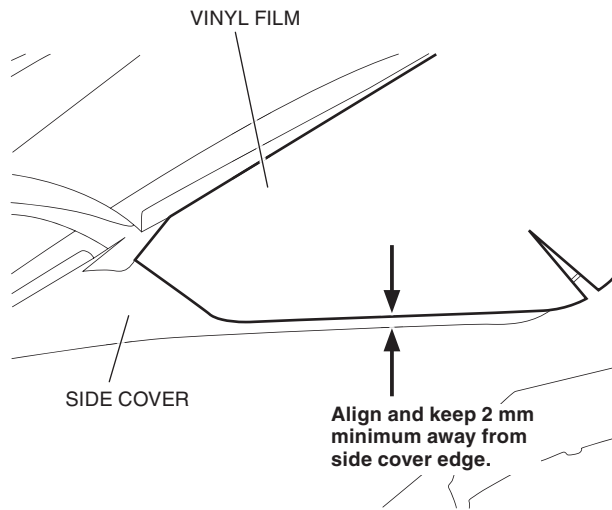

Complete a final alignment check prior to removing the adhesive backing protection.

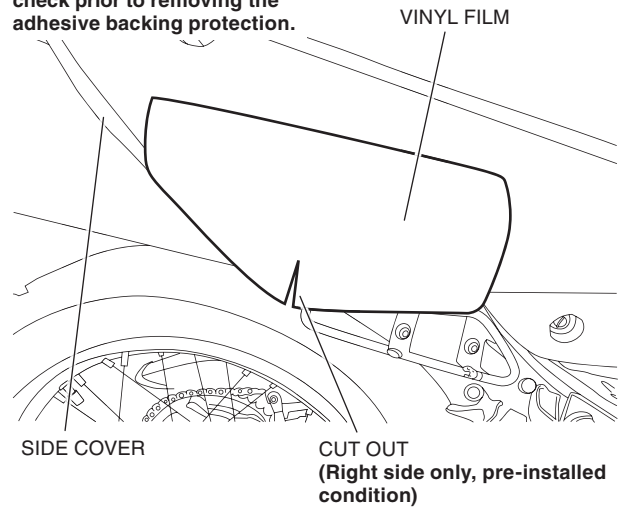

- Repeat steps 2 and 3 above for the left side template.

# TEMPLATE FOR OPTIONAL VINYL FILM (XR150L LEFT SIDE)

Print templates at 1:1 scale to ensure proper fit during installation.

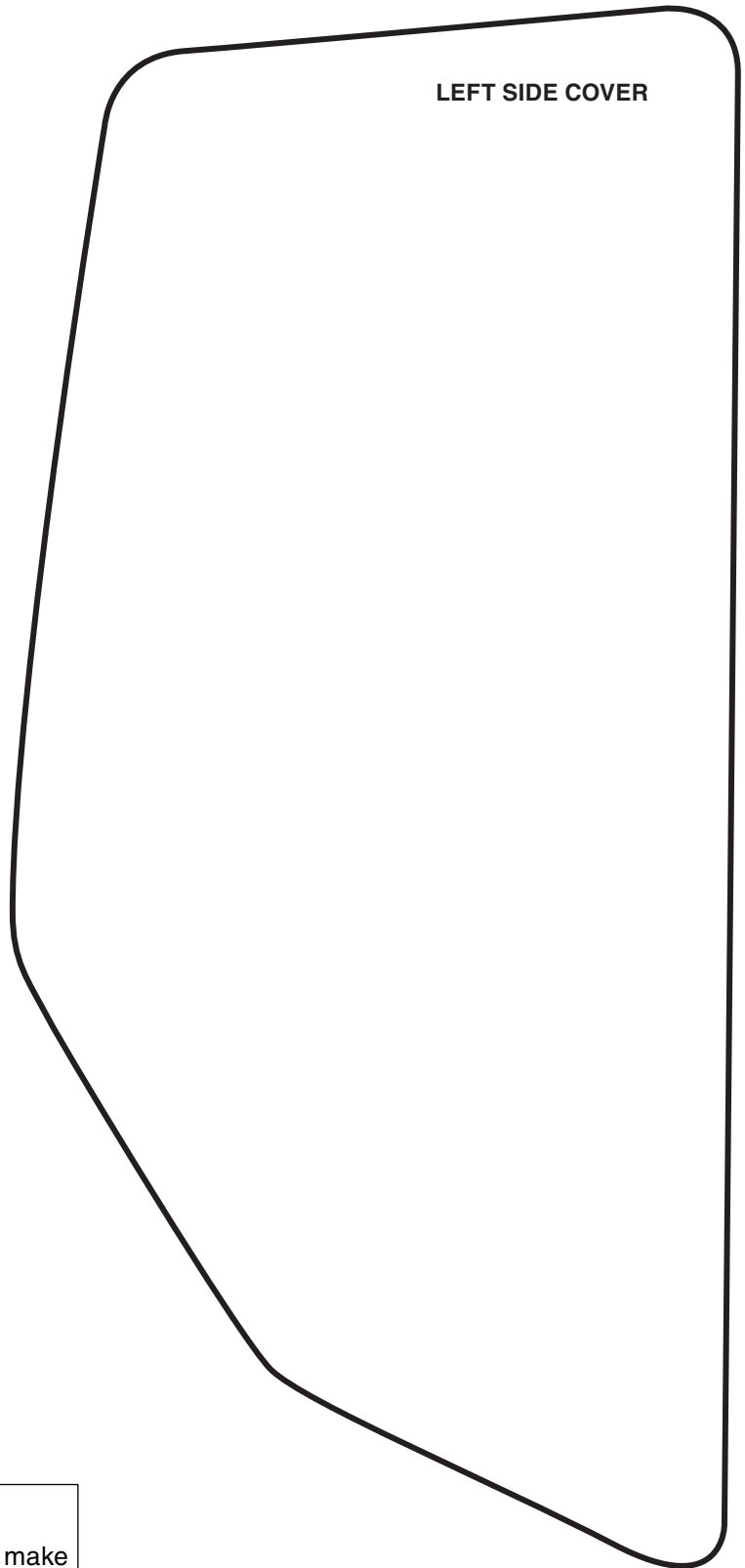

LEFT SIDE COVER

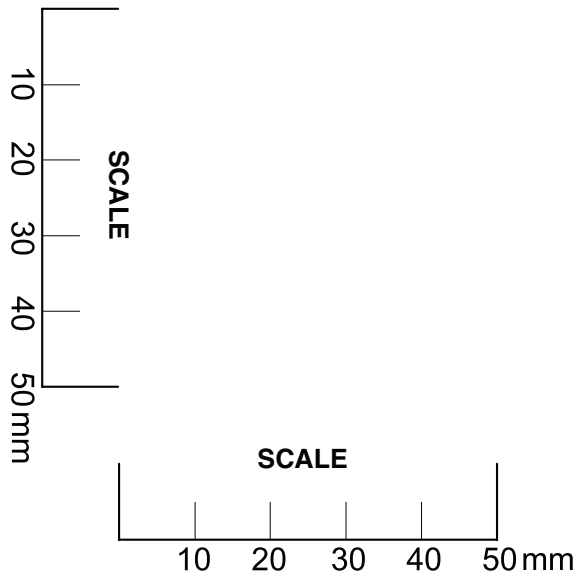

**NOTICE**  
If you print this template from your local computer, make sure the printer settings do not “scale” or “shrink” the page.

# TEMPLATE FOR OPTIONAL VINYL FILM (XR150L RIGHT SIDE)

Print templates at 1:1 scale to ensure proper fit during installation.

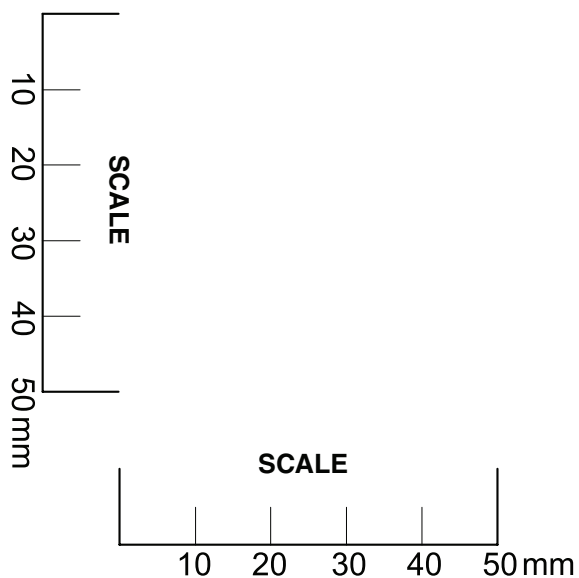
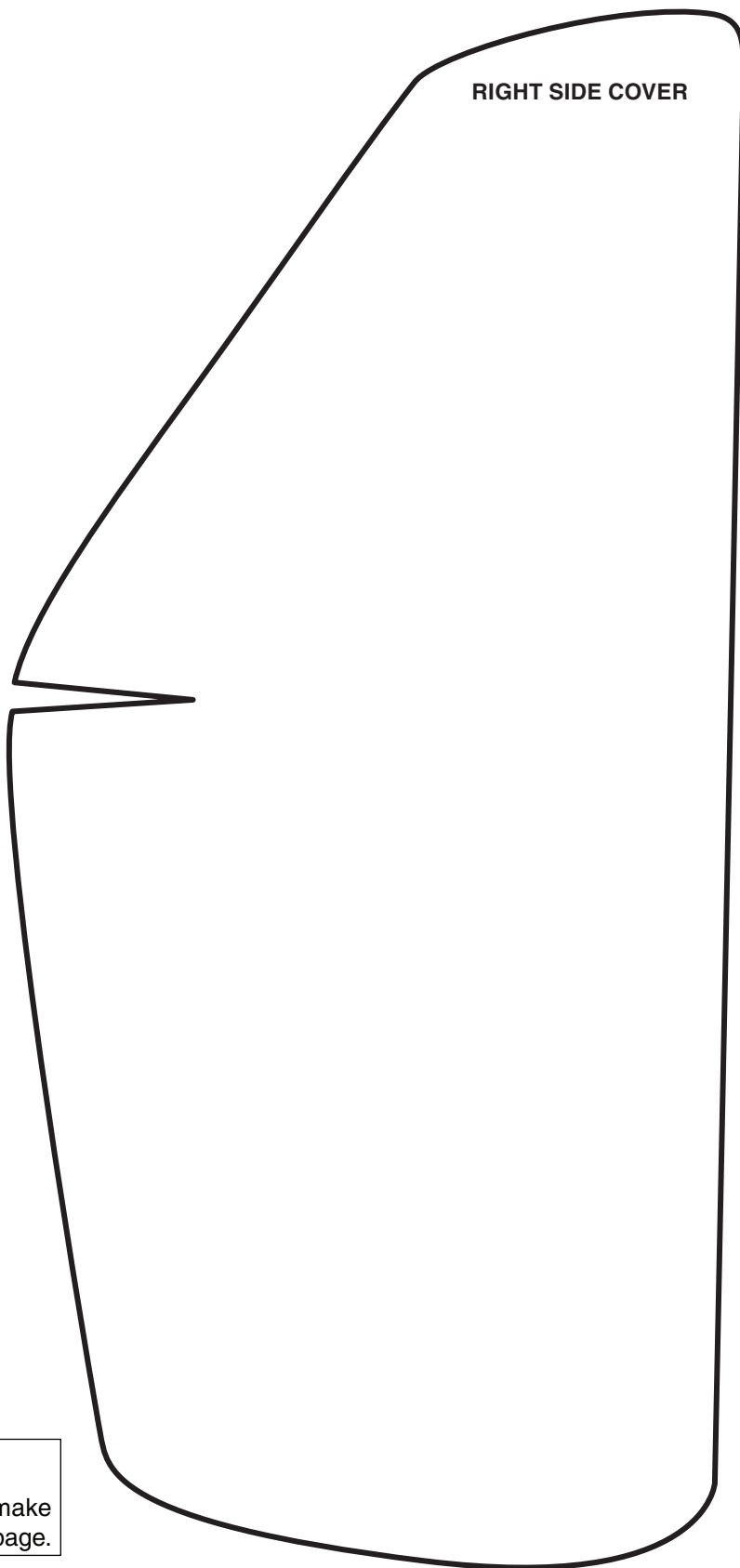

## NOTICE

If you print this template from your local computer, make sure the printer settings do not “scale” or “shrink” the page.

## TEMPLATE DIRECTIONS (CRF300L/LA/LD AND CRF300L/LRA ONLY)

1. Print out the templates at the end of these instructions. Make sure the printed template size is correct by confirming the actual length measurement on the scale legend shown. Once the size is confirmed correct, use a pair of scissors to cut out the paper template.
2. Place a sheet of the protector seal vinyl film on the table/work area with the shiny side down ("3M" logo facing up). Place the paper template on top of the vinyl film. Using a marker, trace the paper template shape onto the vinyl film. Flip the template over and repeat the process on the second sheet of vinyl film. You should end up with two vinyl sheets with mirrored images, one for the right-side saddle bag and one for the left-side saddle bag. Once complete, cut out the shapes on the vinyl sheets.
3. To fit the vinyl to the unit's left-side panel, first decide which vinyl cutout to use (shiny side should face you, "3M" logo should not). Remove the backing and expose the adhesive side. Align the back corner of the vinyl with the back corner of the panel and press firmly. Working toward the front of the unit, stretch the vinyl so that the bottom of the vinyl edge aligns with the bottom of the panel. Press the vinyl to the panel, pressing air bubbles out as you go. The vinyl will fold over itself when you do this. This is necessary for the vinyl to take the shape of the surface of the panel. Once the bottom edge of the vinyl is aligned with the bottom edge of the panel, push the vinyl upward and forward to cover the rest of the panel.

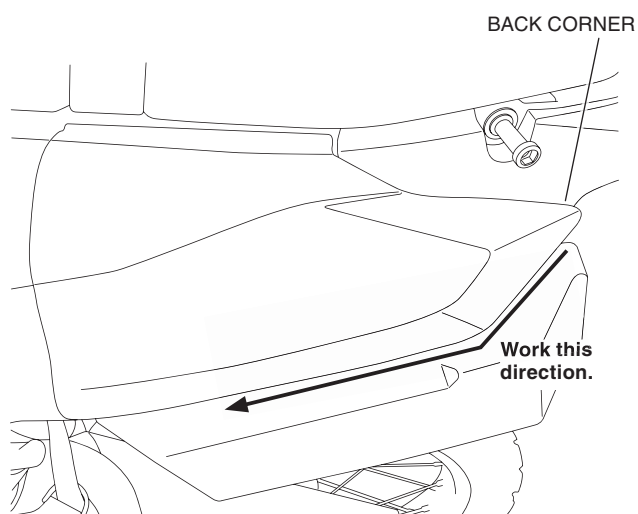

4. Repeat step 3 with the other vinyl cutout on the right-side unit panel.

# **TEMPLATE FOR OPTIONAL VINYL FILM (CRF300L/LA/LD AND CRF300LR/LRA LEFT AND RIGHT SIDE)**

Print templates at 1:1 scale to ensure proper fit during installation.

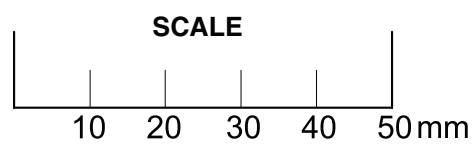
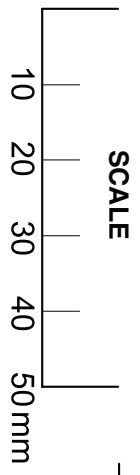
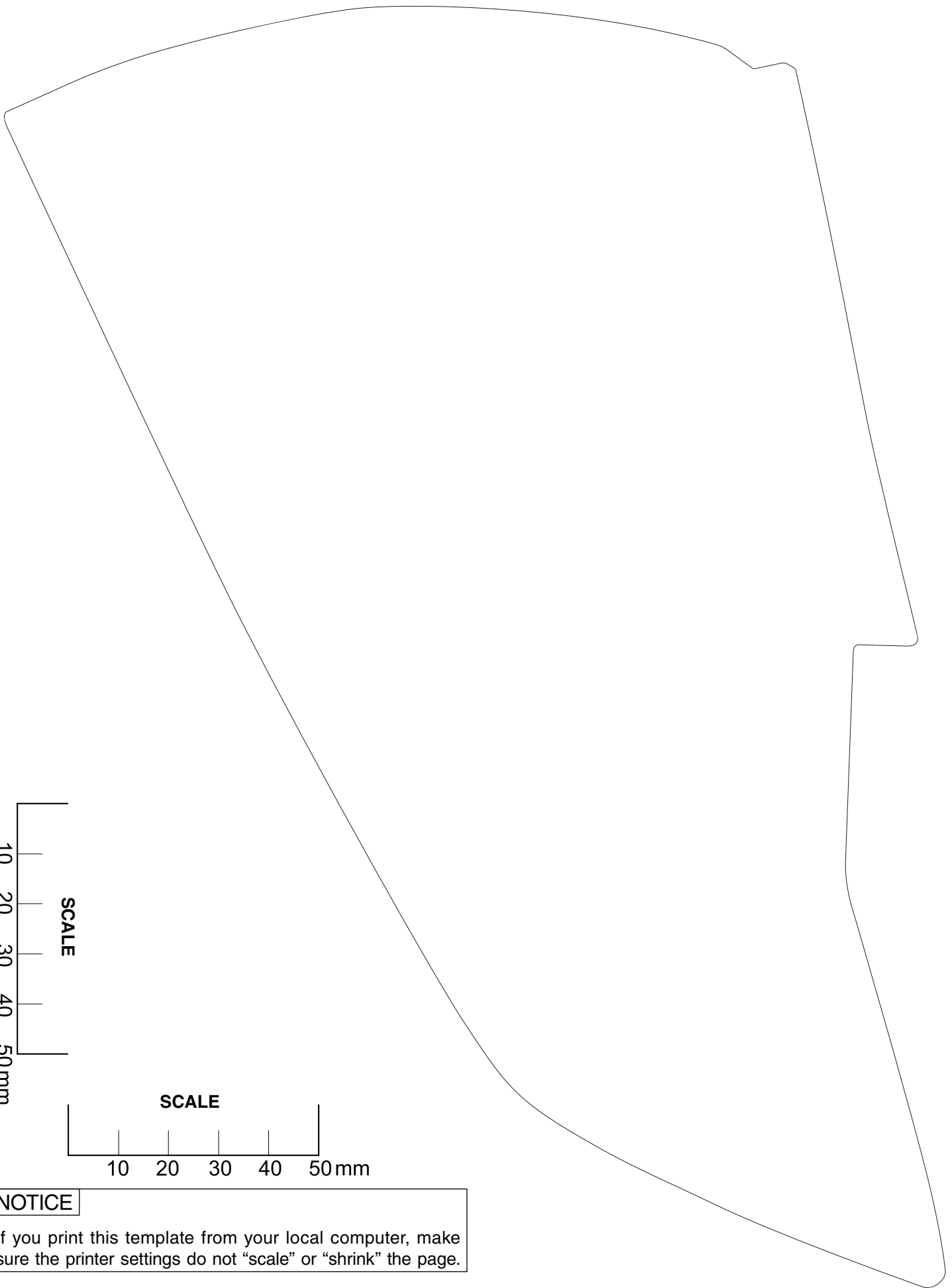

**NOTICE**  
If you print this template from your local computer, make sure the printer settings do not “scale” or “shrink” the page.