



INSTALLATION INSTRUCTIONS

Accessory

**HEATER KIT
P/N 0SE01-HL3-104**

Application

SXS700M2/M2D/M4/M4D

Publication No.

MII 14607-15172

Issue Date

October 2014

Honda Dealer: Please give a copy of these instructions to your customer.

PARTS LIST

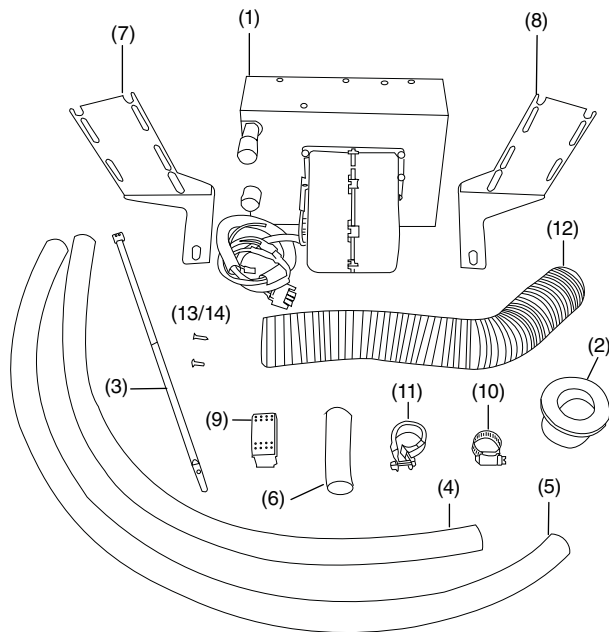

No.	Description	Qty
(1)	Heater Core	1
(2)	Heater vent/louwer	4
(3)	Wire-tie	20
(4)	Heater hose, 3/4 x 84 inch	1
(5)	Heater hose, 3/4 x 87 inch	1
(6)	Heater hose sheath, 3 inch*	5
(7)	Left bracket	1
(8)	Right bracket	1
(9)	Switch	1
(10)	Hose clamp	4
(11)	P-clamp assembly	2
(12)	Heater vent hose	4
(13)	#6 x 5/8 in tapping screw	16
(14)	8-32 x 3/8 in pan head screw	8
(15)	Installation Instructions URL (not shown)	1

* The hose sheaths may not have been cut lengthwise. Cut the hose sheaths lengthwise if necessary.

AUXILIARY WIRE HARNESS Sold separately

The Auxiliary Wire Harness is required for the installation of this accessory.

- Auxiliary Wire Harness - P/N OSA30-HL3-100

TOOLS & SUPPLIES REQUIRED

- | | |
|-------------------------|----------------------------|
| Socket, 10 mm | Razor knife |
| Socket, 8 mm | Combination wrench, 8mm |
| Ratchet | Drain pan (engine coolant) |
| #2 Phillips screwdriver | Pro Honda HP Coolant |
| Flat blade screwdriver | Funnel |
| Hole saw (2 inch) | Power drill |
| Nut driver (5/16 inch) | |
| Awl | |

INSTALLATION

▲ WARNING

- Removing the radiator cap while the engine is hot can allow the coolant to spray out, seriously scalding you. Always let the engine and radiator cool down before removing the radiator cap or disconnecting any cooling system hoses.

NOTE:

- Use a clean drain pan so that the engine coolant can be reused after installation is complete.
- When installing the heater and the required Auxiliary Wire Harness, install the Heater Kit first.
- Make sure the coolant level in the radiator reserve tank is at the MAX level line before heater installation.

1. Refer to the Service Manual for the vehicle, remove the front under guard and middle under guard.
2. Refer to the Service Manual for the vehicle, drain the engine coolant from the cooling system into a clean drain pan.
3. Install the right and left mounting brackets to the heater core using the eight 8-32 pan screws.

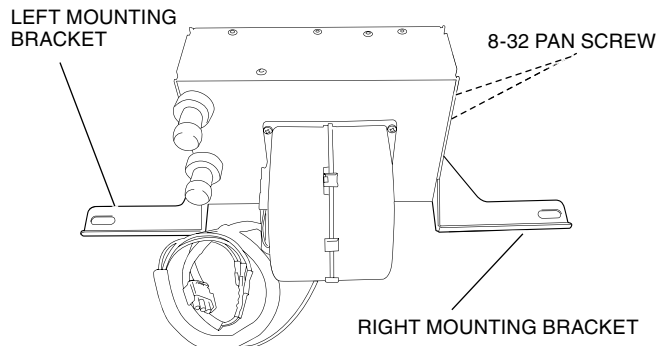

4. Remove the clips from the vent assembly as shown.

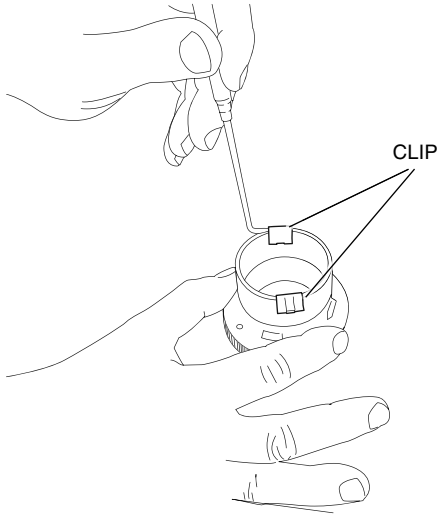

5. Place a large socket into the back side of the vent assembly as shown.

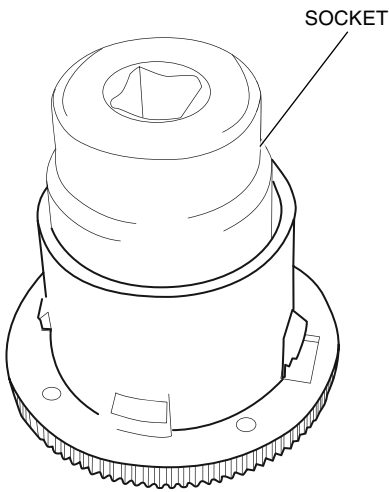

6. Knock out the louver from the vent mounting flange as shown.

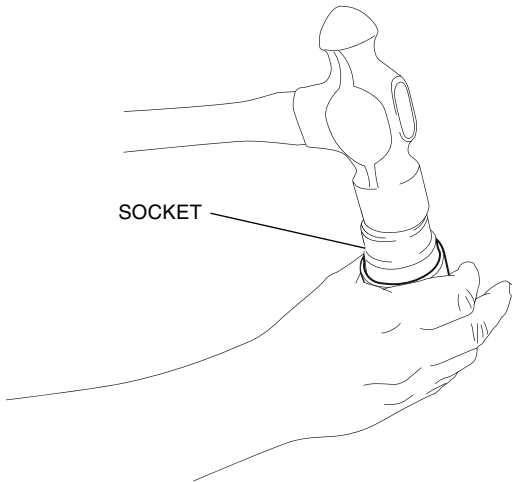

7. Cut the drilling templates out from page 8.

Align the reference arrows with the trim clips or the top of the *Shift-Drive* decal as indicated on each template.

Tape the drilling templates to the dash panel at the positions shown.

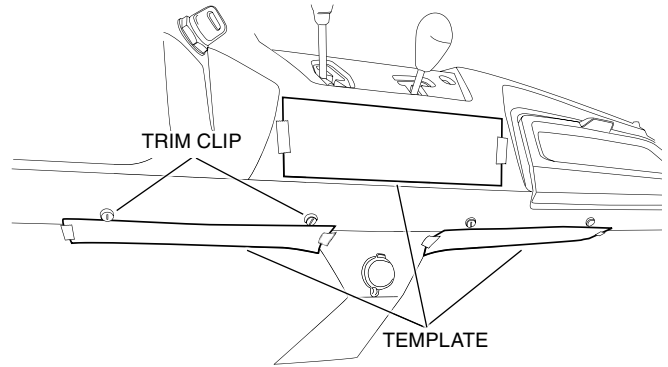

8. Make drill marks on the dash panel by pushing an awl through the cross-hair marks on each drilling template.

Remove the templates.

Drill holes through the four marked points in the dash panel with a 2 inch hole saw.

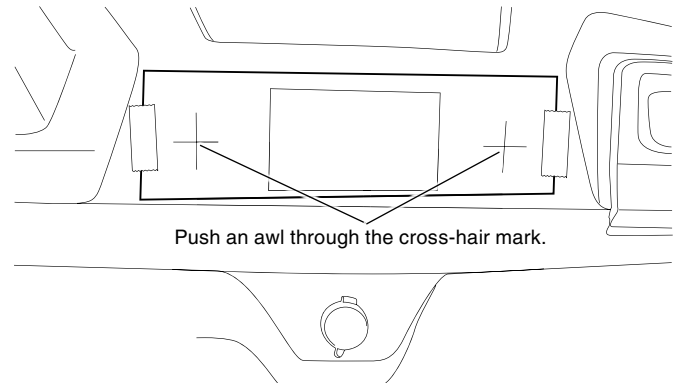

9. Install a vent mounting flange to each hole with four #6 x 5/8 inch tapping screws as shown.

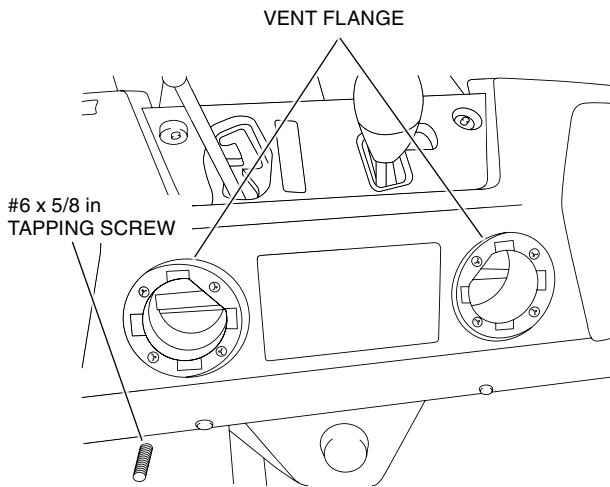

10. Install the louver into each vent mounting flange as shown and then reinstall the two clips to each vent assembly.

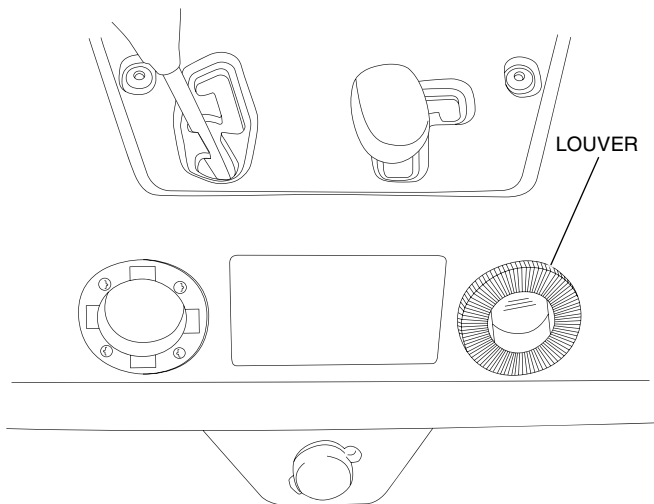

11. Install a 2 inch vent hose to the back of each installed vent assembly and secure it with a wire-tie.

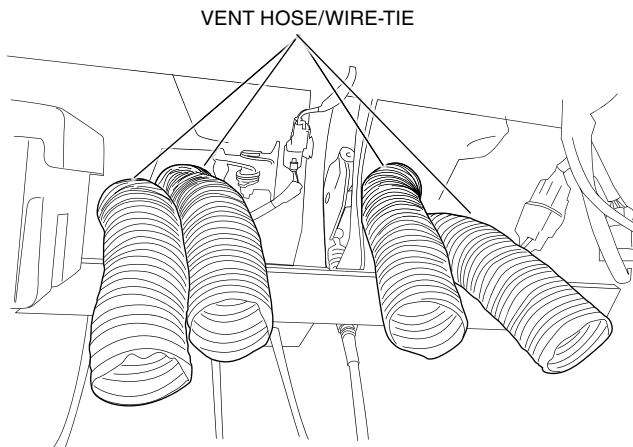

12. Remove the inner fender bolts at the locations shown.

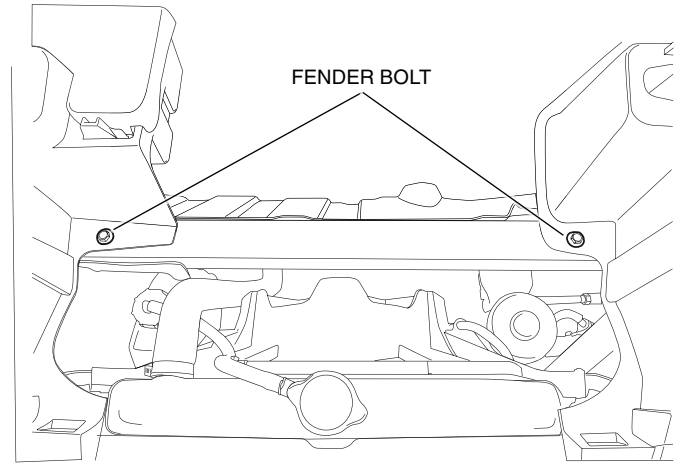

13. Remove the caps from the heater core inlet/outlet fittings.

Prepare the heater core for installation by filling it with engine coolant until all the air is expelled from the core.

Reinstall the caps onto the inlet/outlet fittings.

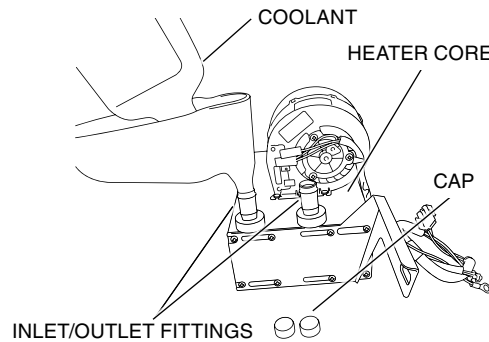

14. Install the heater core to the frame cross member by sliding the mounting brackets under the fenders.

Reinstall the fender bolts removed in Step 13 and install the black wire ground terminal to the right (passenger side) fender bolt as shown.

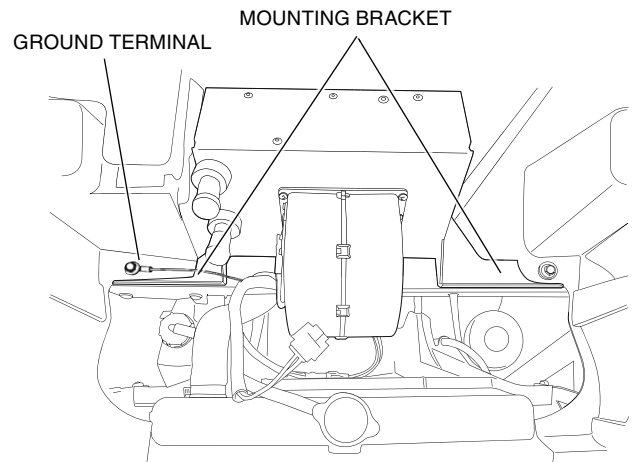

15. Route each heater vent hose from the dash panel to the back side of the heater core. Secure each vent hose to a spigot on the heater core with a wire-tie.

16. Refer to the Service Manual for the vehicle, remove the following components:

- Seat cushion
- Front seat backrest
- Seat bottom covers (left, then right)

17. Locate the coolant hose that runs between the cylinder block and the oil cooler.

Remove the coolant hose and hose clamps and save them.

<VIEW FROM THE RIGHT SIDE>

COOLANT HOSE/CLAMPS
(Save)

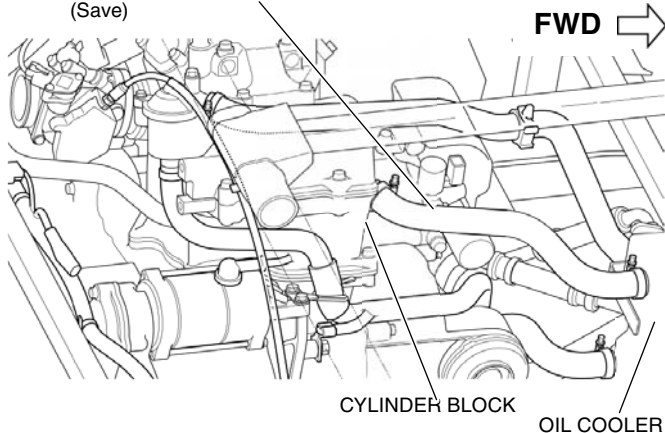

18. Install the **84 inch (short)** heater hose to the cylinder block fitting with a hose clamp as shown.

Route the heater hose forward, toward the radiator.

<VIEW FROM LEFT SIDE>

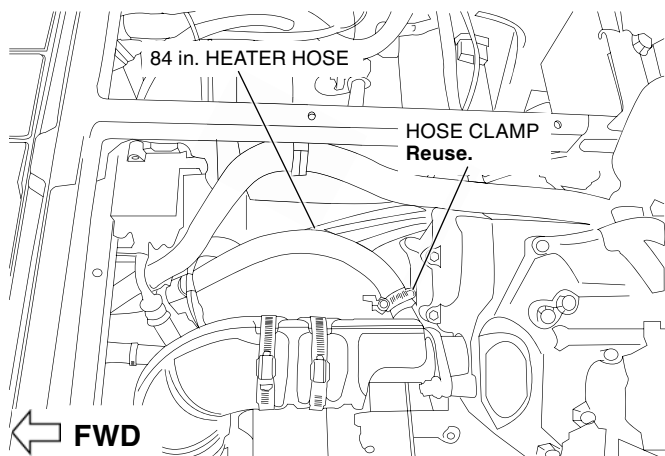

19. Install the **87 inch (long)** heater hose to the oil cooler fitting with a hose clamp as shown.

Route the heater hose down and into a “U” shape, then forward toward the radiator as shown.

<VIEW FROM LEFT SIDE>

OIL COOLER

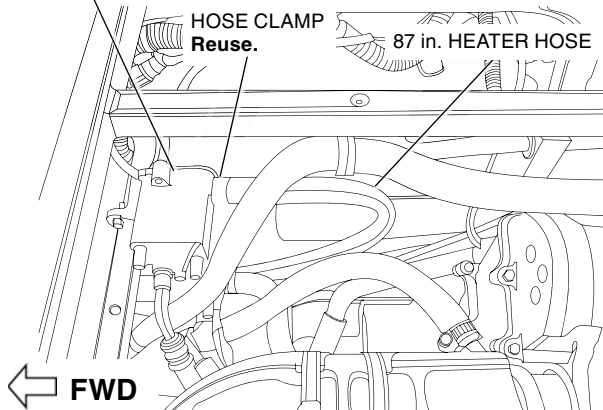

20. Route the heater hoses forward, then up **along the passenger side of the steering column**, and then to the left of the heater core as shown.

Install a hose clamp over the end of each heater hose at this time.

Make sure the end of each heater hose is above the level of the radiator cap.

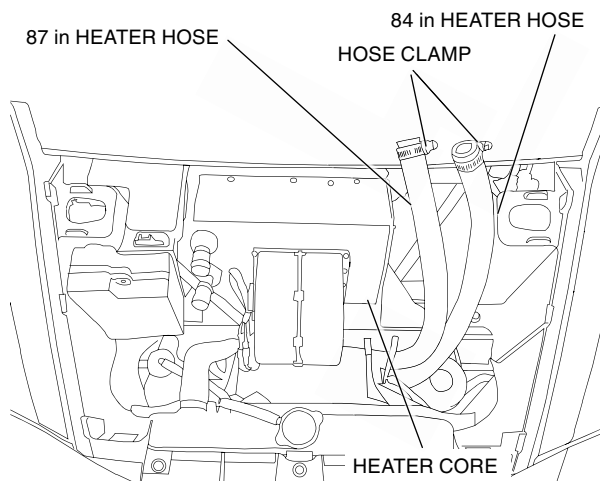

21. Remove the bleed bolt and sealing washer from the thermostat cover, and loosely install the bolt with a new sealing washer.

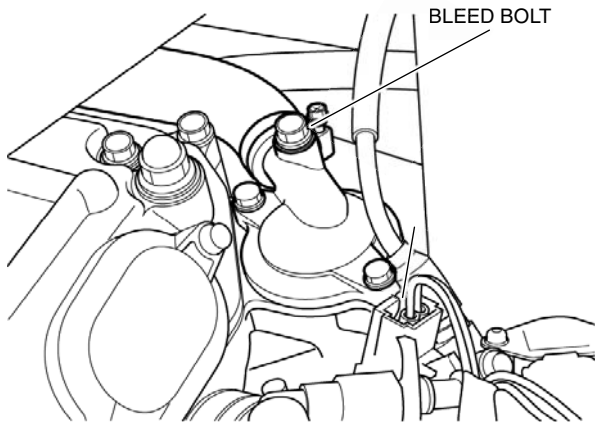

22. Place the shop towels around the bleed bolt. Fill the system with the previously drained coolant up to the filler neck. Tighten the bleed bolt as soon as coolant starts to run out in a steady stream without bubbles.

TORQUE: 12 N·m (1.2 kgf·m, 9 lbf·ft)

Reinstall the radiator cap.

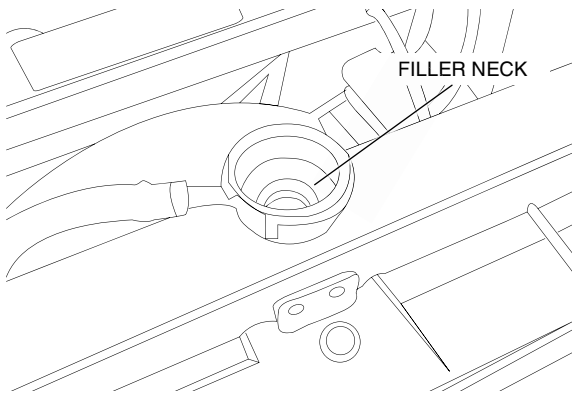

23. Continue filling the cooling system by pouring coolant into the heater hoses until each hose is completely full.

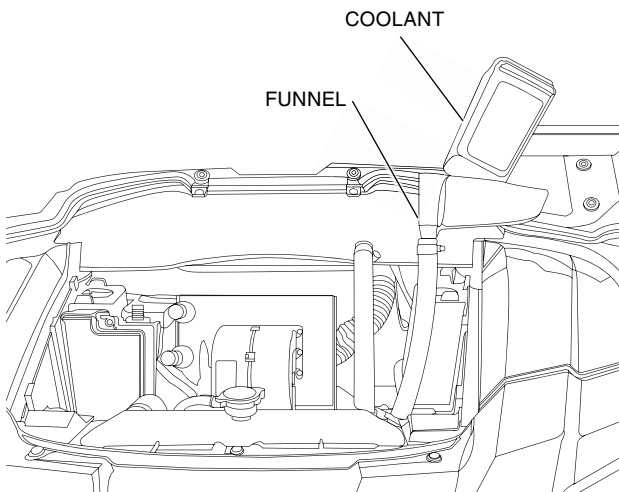

24. NOTE: Work quickly when connecting the heater hoses to the heater core to minimize any air entering or coolant loss from the heater core.

- A. Connect the **87 in (long)** heater hose to the **bottom** copper fitting on the heater core. Secure the hose with the hose clamp as shown.
- B. Add coolant to the **84 in (short)** heater hose if necessary and connect it to the **upper** copper fitting on the heater core. Secure the hose with the hose clamp as shown.

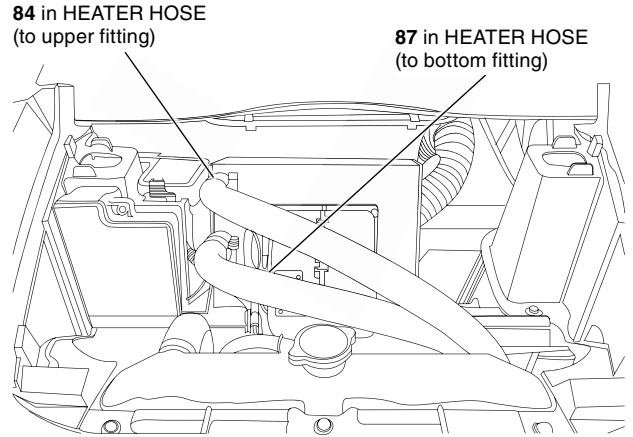

25. Secure the heater hoses to the heater core mount with the P-clamps as shown.

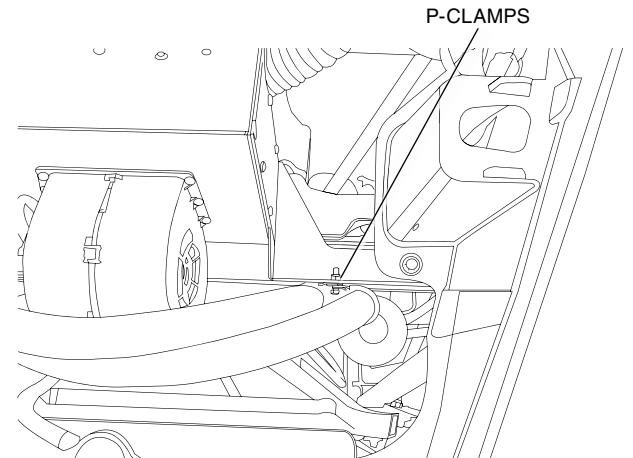

26. Install the five hose sheaths to the heater hoses at the locations shown.

Secure the sheaths with wire ties.

- Use extra wire ties as necessary to ensure that the heater hoses do not contact any sharp edges or moving parts.

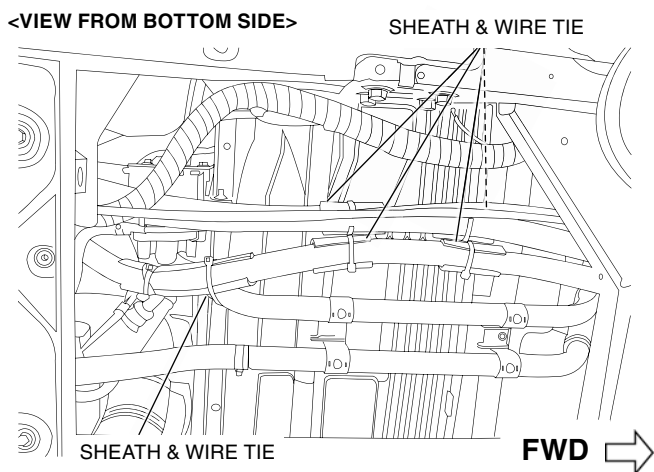

27. Secure the short heater hose and sheath (from cylinder block) to the bottom of the lower oil line with two wire ties as shown.

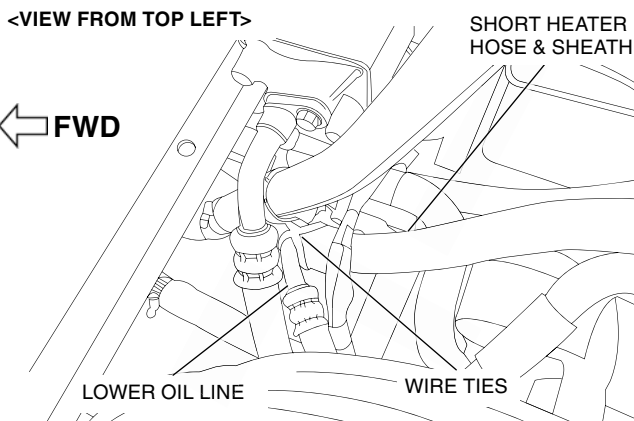

28. Secure the heater hoses to the cable bundle with a wire tie at the location shown.

- Use extra wire ties as necessary to ensure that the heater hoses do not contact any steering components.

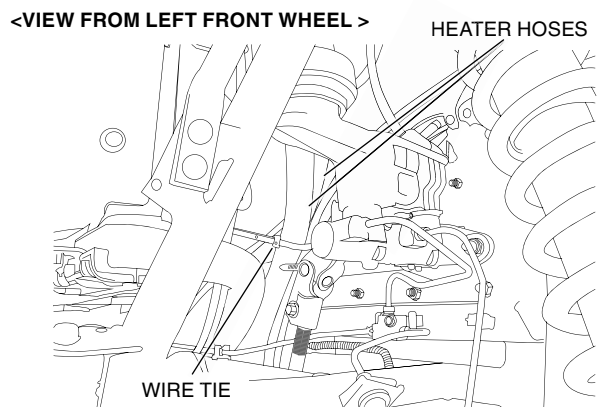

29. Proceed to the installation of the Auxiliary Wire Harness if it is not already installed. Connect the heater fan harness to the HEATER terminal of the fuse box circuit board.

Install the supplied heater switch to the switch plate and connect it to the switch harness.

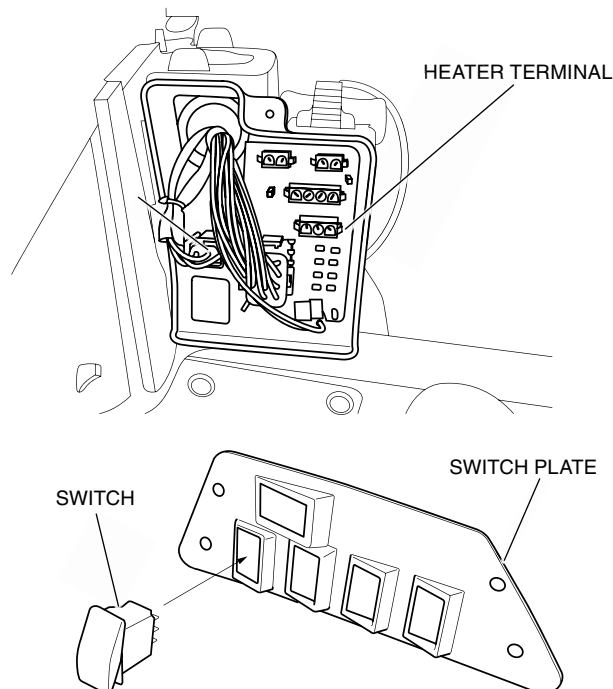

TEST THE COOLING SYSTEM AND HEATER

1. Start the engine and allow it to run for at least 5-10 minutes and until the thermostat opens. During warm-up, run the engine at half-throttle for short bursts to facilitate warm up. The engine is warm when the bottom radiator tank is hot to the touch.
2. Turn the ignition switch off and allow the engine to cool down.
3. After the engine cools down check the coolant level in the radiator reserve tank.
4. It is normal that some coolant should have been consumed from the tank during cool down. Add coolant until the level is at MAX.
5. Warm up the engine again and test drive the vehicle to check the heater system performance.
6. After the test drive, check the coolant level in the radiator reserve tank and add coolant as necessary.
7. Check the installed heater hoses and fittings for leaks.
8. Check the orientation of the installed heater hoses and make sure they do not contact sharp edges or moving parts such as the steering joint. Adjust the location of hoses as necessary with wire ties.

REINSTALL THE REMOVED PARTS

Refer to the Service Manual for the vehicle, reinstall the removed parts in the reverse order of removal.

**THIS PAGE LEFT BLANK
INTENTIONALLY**

