

Honda Dealer: Please give a copy of these instructions to your customer.

PARTS LIST

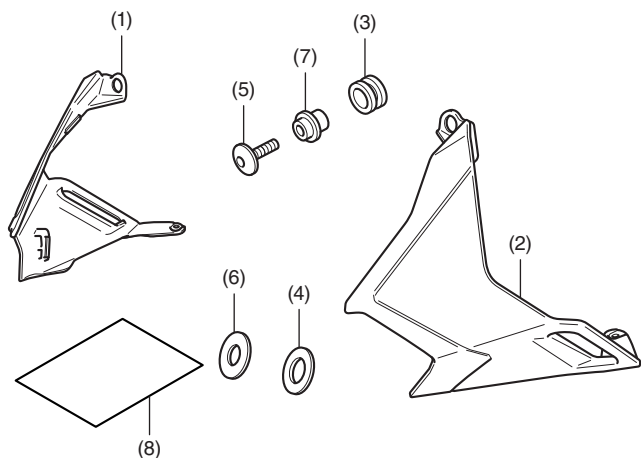

No.	Description	Qty
(1)	Right wind deflector	1
(2)	Left wind deflector	1
(3)	Grommet	2
(4)	Rubber washer	2
(5)	5 mm screw	2
(6)	Washer	4
(7)	Collar	2
(8)	Installation Instruction URL	1

TOOLS AND SUPPLIES REQUIRED

Hex wrench (5 mm)

Isopropyl alcohol

Shop towel

Torque wrench

TORQUE CHART

Tighten all screws, bolts, and nuts to their specified torque values. Refer to the Service Manual for the torque values of the removed parts.

Item	N·m	kgf·m	lbf·ft
5 mm screw	4.2	0.5	3.8

INSTALLATION

NOTE:

- Heat the bonding surfaces with a hair dryer if the ambient air temperature is below 70°F (21°C).
- The adhesive reaches full strength in 72 hours. Wait at least 24 hours before riding your motorcycle.

1. Remove the screws as shown.

<Left side>

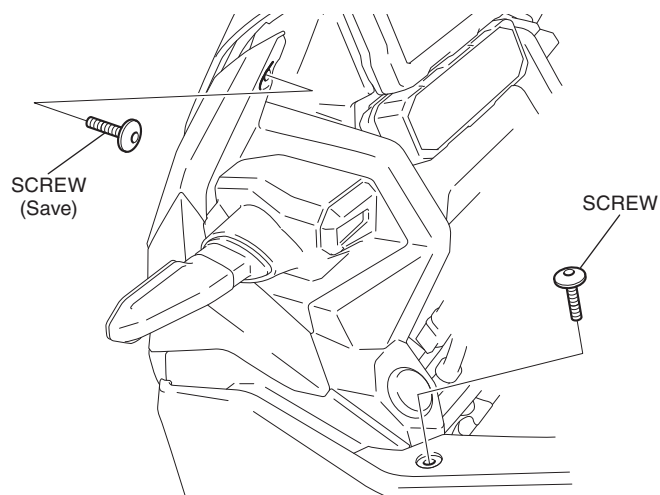

2. Clean the surface of the area shown using isopropyl alcohol.

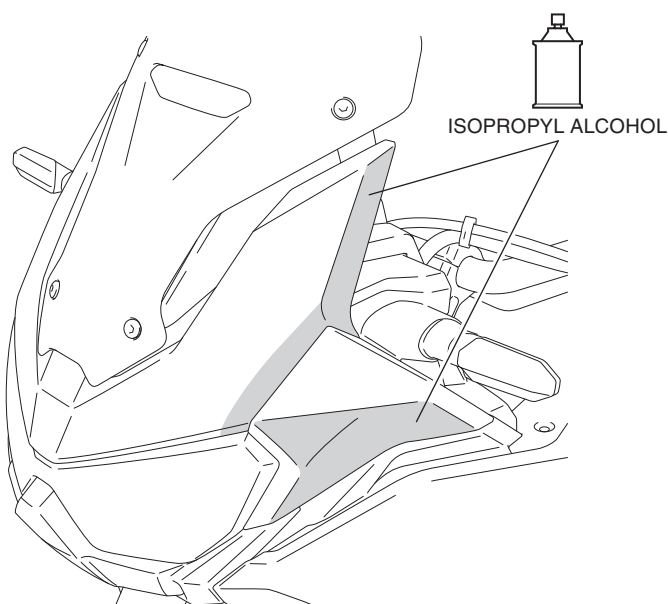

3. Install the grommet as shown.

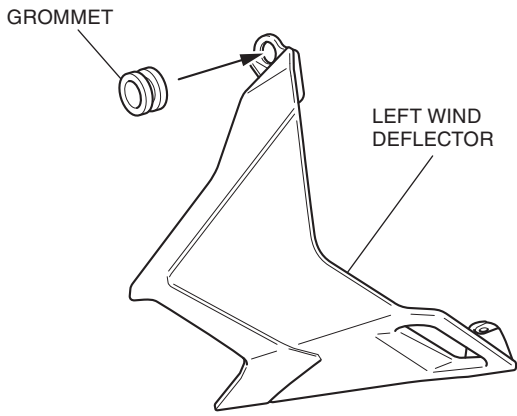

4. Peel off the adhesive backing on the left wind deflector as shown.

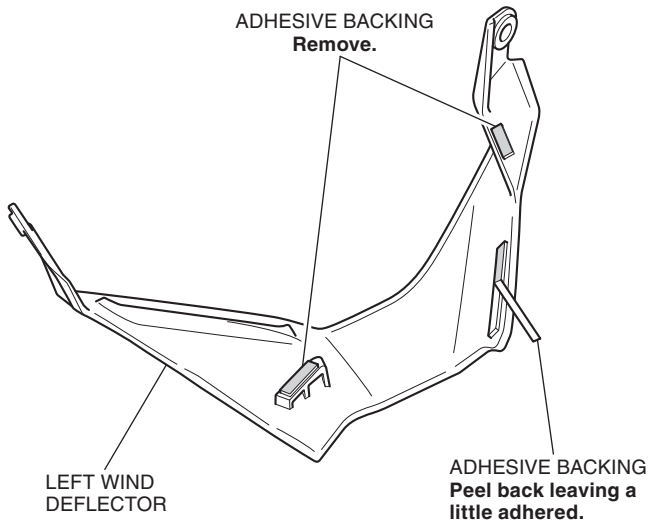

5. Install the collar as shown.

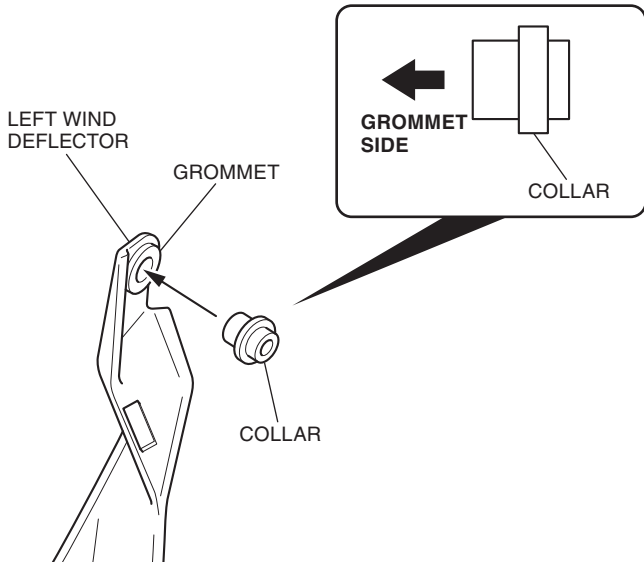

6. Install the left wind deflector as shown.

<Left side>

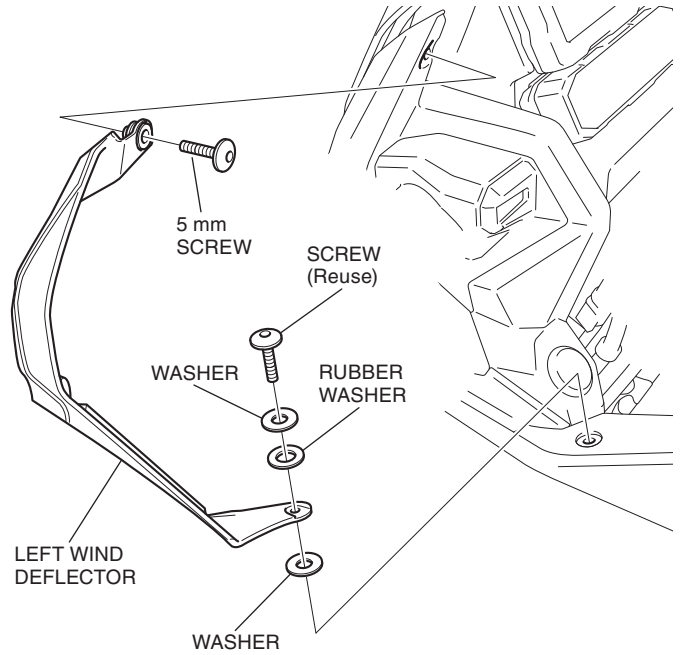

7. Remove the adhesive backing as shown.

<Left side>

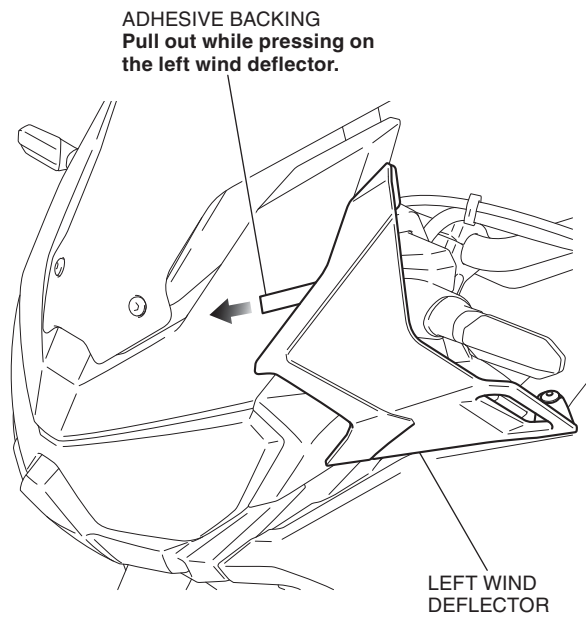

8. Apply adequate pressure to the attached left wind deflector.

9. Install the right wind deflector in the same manner as the left side.