

Accessory	Application	Publication No.
FRONT BUMPER P/N 08P73-HL5-A00	SXS500M2	MII 14948
		Issue Date
		June 2014

Honda Dealer: Please give a copy of these instructions to your customer.

PARTS LIST

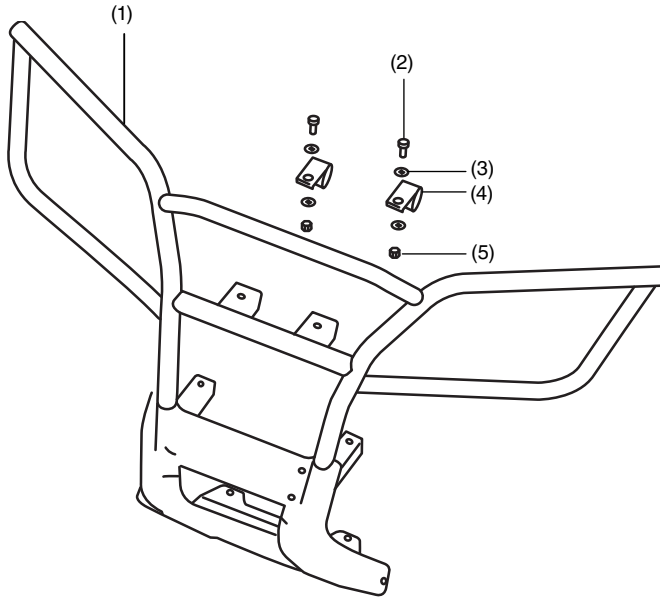

No.	Description	Qty
(1)	Front bumper	1
(2)	10 mm bolt	2
(3)	10 mm washer	4
(4)	P-Bracket	2
(5)	10 mm nut	2

TOOLS AND SUPPLIES REQUIRED

Torque Wrench
12 mm Socket
14 mm Socket
12 mm Wrench
Ratchet

TORQUE CHART

Tighten all screws, bolts, and nuts to their specified torque values. Refer to the Service Manual for the torque values of the removed parts.

Item	N-m	kgf-m	lbf-ft
8 mm bolt	18	1.8	12.5
10 mm bolt	39	4.0	28.8

USE AND CARE INFORMATION

Check the accessory mounts frequently and retighten if necessary.

INSTALLATION

1. Remove the two lower 10 mm bolts from the stock bumper as shown.

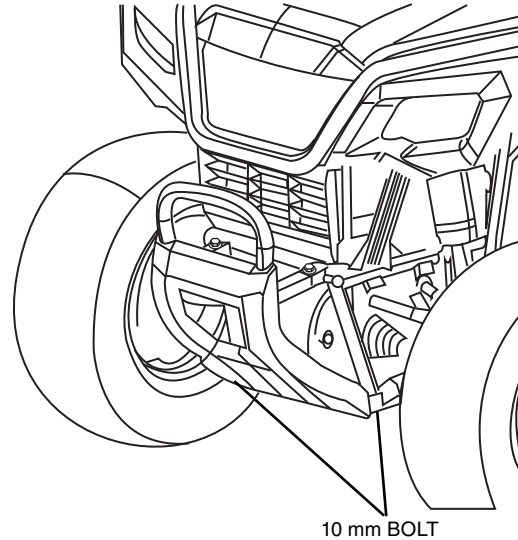

2. Remove two upper 8 mm bolts and nuts from stock bumper as shown.

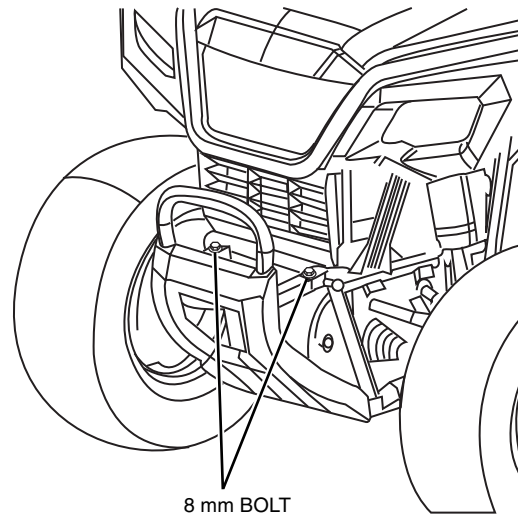

3. Remove the stock bumper from the vehicle.

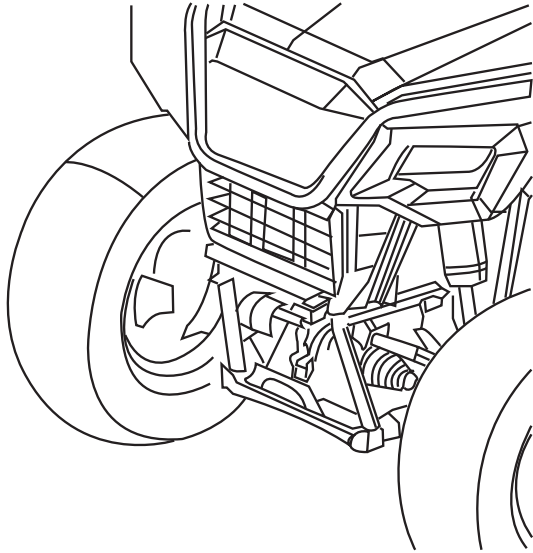

4. Place the accessory front bumper in the same position as the stock bumper.

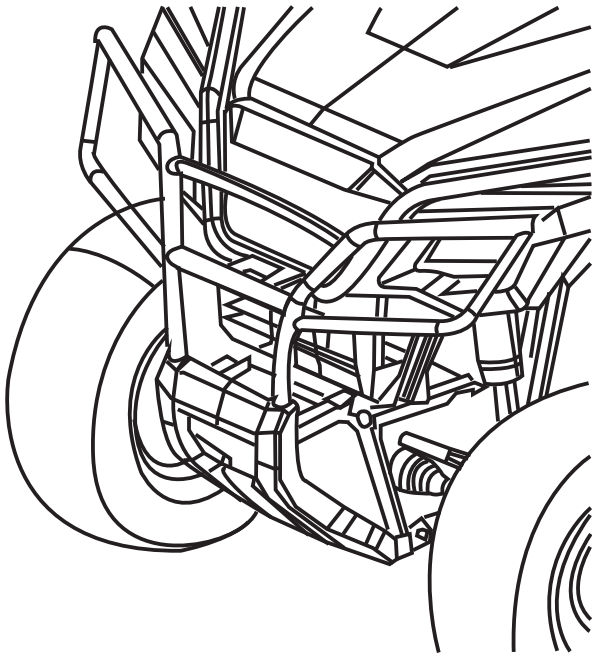

5. Loosely install the bumper using the supplied P-bracket, 10 mm bolt, nut, and washers. Use a washer on each side of the P-Bracket. Loosely install the two upper 8 mm bolts and nuts.

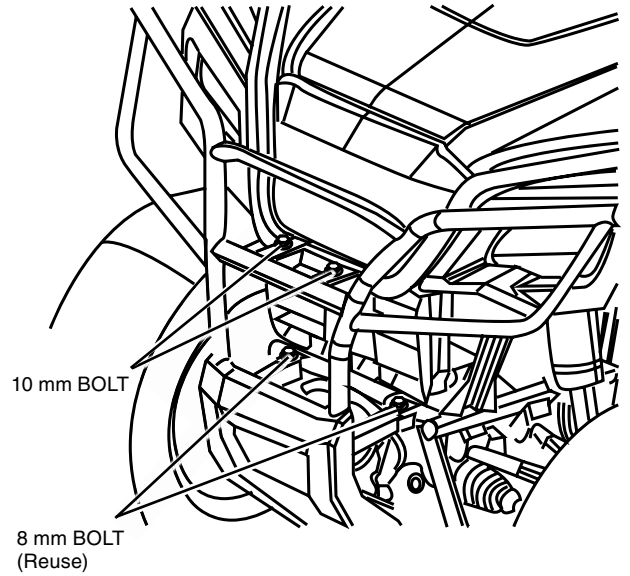

6. Loosely install the two lower 10 mm bolts.

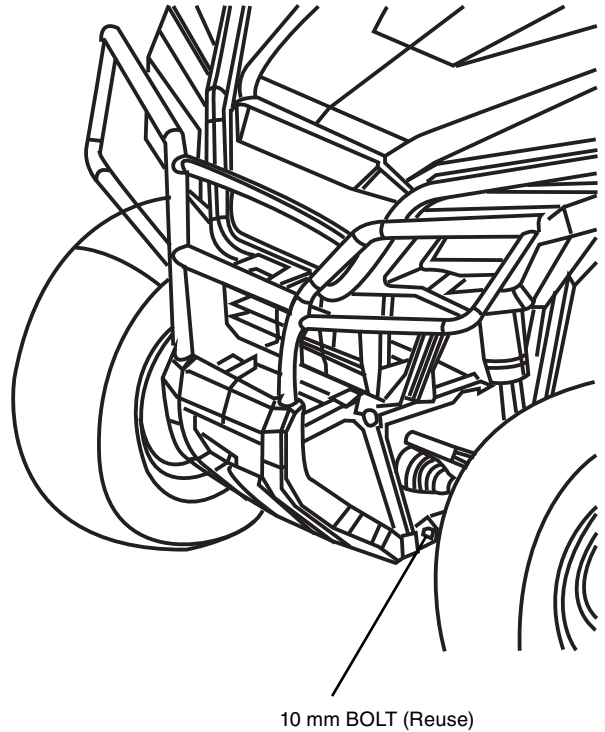

7. Tighten all hardware to values specified in the Torque Chart.