

Honda Dealer: Please give a copy of these instructions to your customer.

PARTS LIST

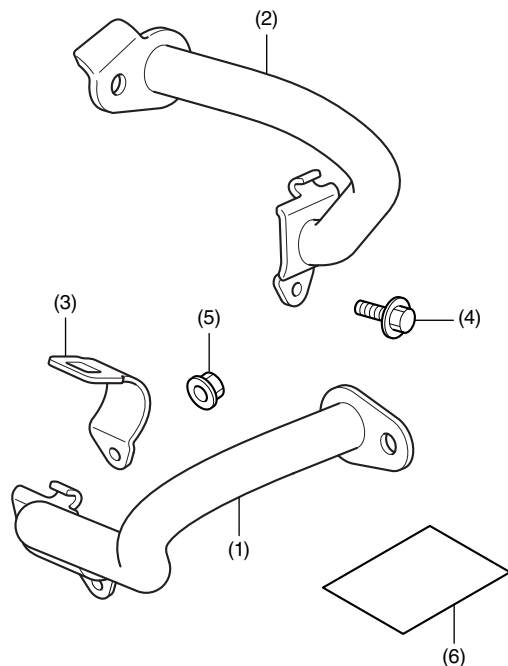

No.	Description	Qty
(1)	Right engine guard	1
(2)	Left engine guard	1
(3)	Lower holder	2
(4)	6 mm flange bolt	2
(5)	6 mm flange nut	2
(6)	Installation Instruction URL	1

TOOLS REQUIRED

Socket (10 mm)
 Ratchet
 Box-end wrench (10 mm)
 Torque wrench

TORQUE CHART

Tighten all screws, bolts, and nuts to their specified torque values. Refer to the Service Manual for the torque values of the removed parts.

Item	N·m	kgf·m	lbf·ft
6 mm flange bolt and nut	12	1.2	9

INSTALLATION

▲ CAUTION

- To prevent burns, allow the engine and exhaust system to cool before installing the accessory.

1. Remove the parts as shown.

<Left side>

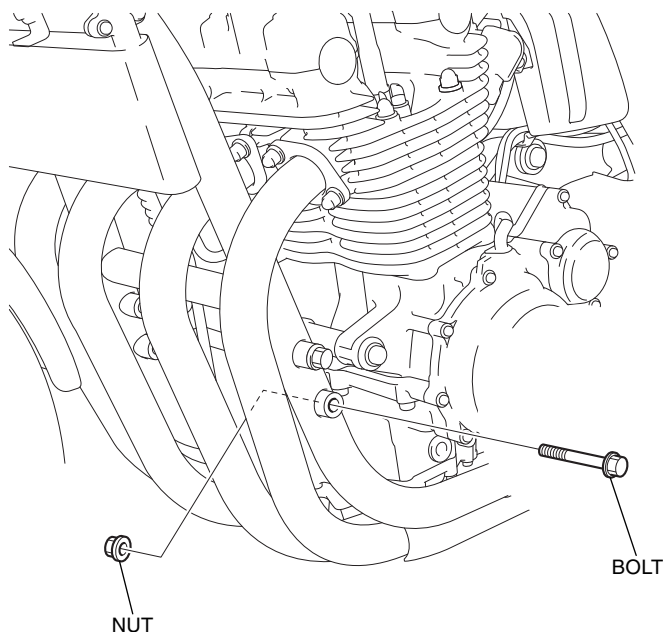

2. Loosely install the left engine guard as shown.

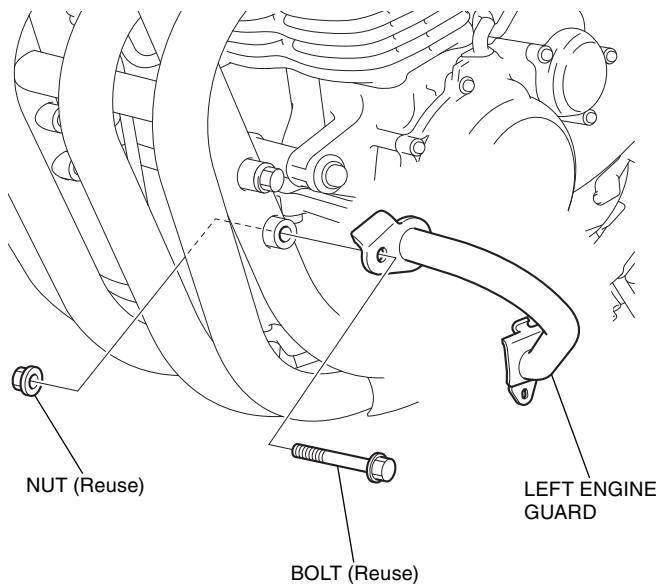

3. Install the lower holder as shown.

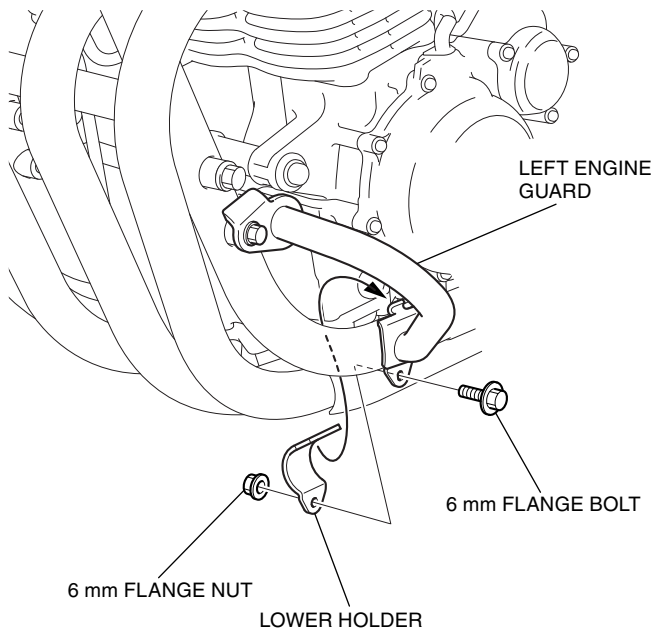

4. Loosely install the right engine guard in the same manner.
5. Install the lower holder to the right engine guard in the same manner.
6. Alternately tighten the loosely installed engine mount bolts to the torque value shown.

