



# HONDA

## INSTALLATION INSTRUCTIONS

Accessory
<b>REAR BUMPER</b> P/N: 08P70-HR3-W50

Application
TRX420FA1/FA2/FE1/FM1/ FM2/TE1/TM1 TRX500FE1/FE2/FM1/FM2

Publication No.
<b>MII 15911</b>
Issue Date
<b>June 2016</b>

### PARTS LIST

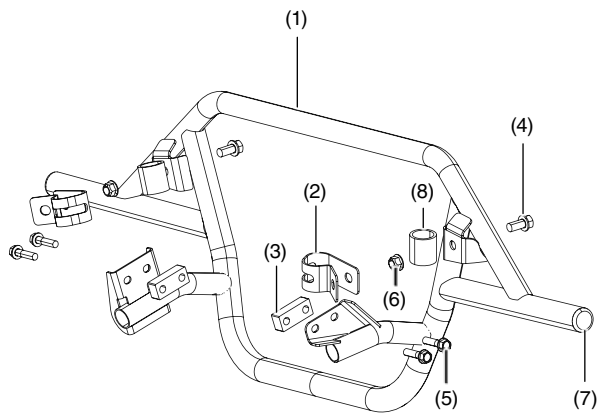

No.	Description	Qty
(1)	Rear bumper	1
(2)	Rear bumper strap	2
(3)	Rear bumper spacer	2
(4)	Flange bolt, 10 x 20 mm	2
(5)	Flange bolt, 8 x 32 mm	4
(6)	Flange nut, 10 mm	2
(7)	Rear bumper pipe end cap	2
(8)	Strap cushion	2

### TOOLS AND SUPPLIES REQUIRED

- 14 mm wrench
- 14 mm socket
- 12 mm socket
- Ratchet
- Torque wrench

### TORQUE CHART

Tighten all screws, bolts, and nuts to their specified torque values. Refer to the Service Manual for the torque values of the removed parts.

Item	N·m	kgf·m	lbf·ft
8 mm flange bolt	26.5	3.0	19.5
10 mm flange bolt and nut	39.0	4.0	29.0

### USE AND CARE INFORMATION

Check the accessory mounts frequently and retighten if necessary.

### INSTALLATION

#### ⚠ CAUTION

- To prevent burns, allow the engine, exhaust system, radiator, etc, to cool before installing the accessory.

1. Remove the four 8 mm flange bolts from the rear carrier located on both sides of the rear tool box.

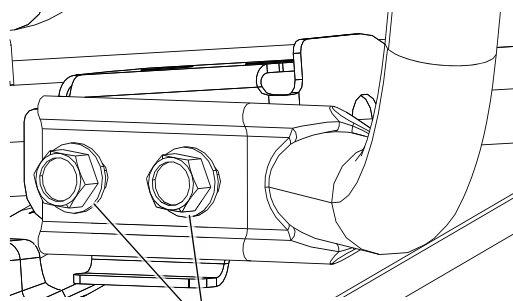

8 mm FLANGE BOLTS (Save)

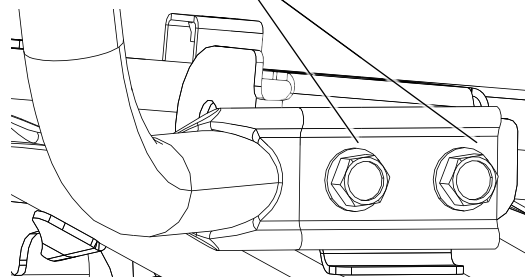

2. Install the rear bumper spacers and rear bumper with four 8 x 32 mm flange bolts as shown. Hand tighten the bolts.

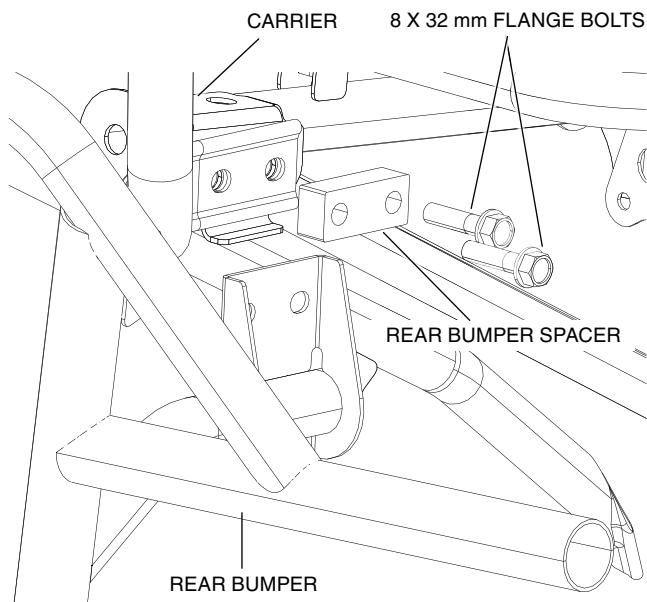
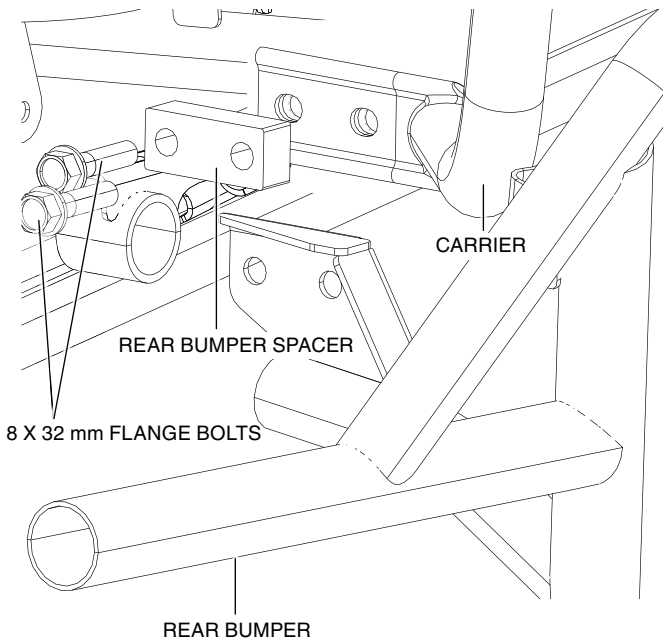

3. Install the strap cushion into the rear bumper strap as shown below.

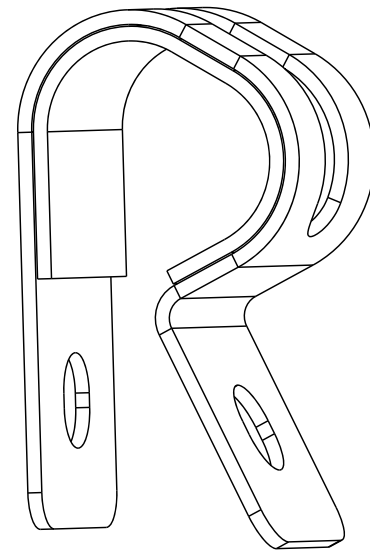
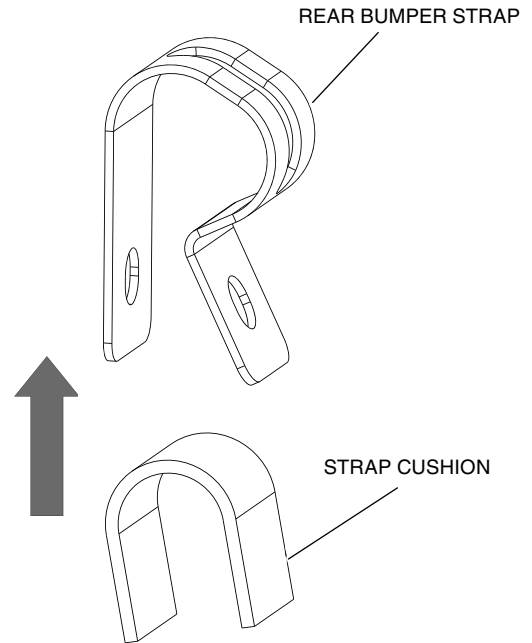

ASSEMBLED STRAP

4. Install the assembled rear bumper straps as shown. Rotate each strap cushion so the seam faces forward as shown.

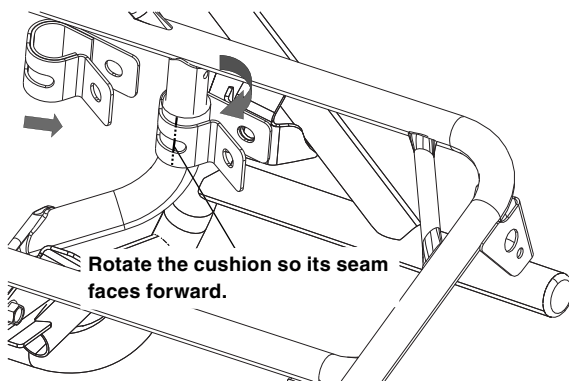
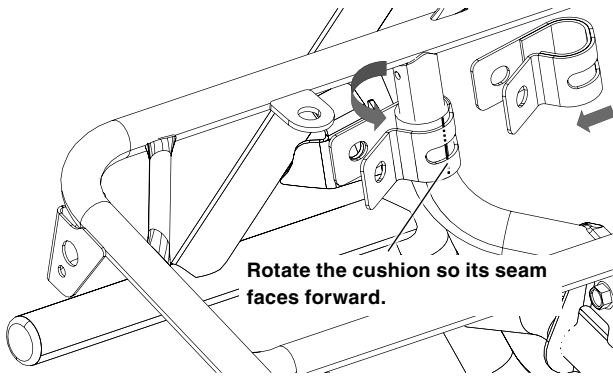

5. Install two 10 x 20 mm flange bolts and two 10 mm flange nuts as shown. Tighten the hardware to the values specified in the Torque Chart.

