

PARTS LIST

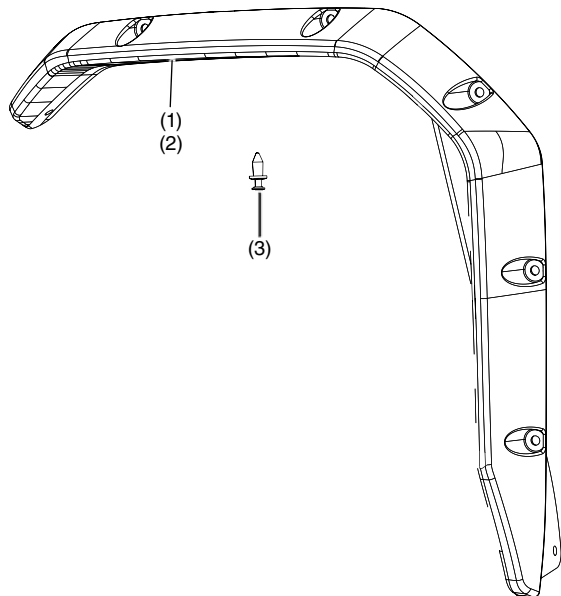

No.	Description	Qty
(1)	Front right fender flare	1
(2)	Front left fender flare	1
(3)	Trim clip	20

TOOLS AND SUPPLIES REQUIRED

Marker
Power drill
Drill bit (8mm)

USE AND CARE INFORMATION

- Replace this accessory with a new one if it is damaged or discolored excessively.
- To clean the fender flare, rinse it thoroughly with cool water to remove loose dirt, and then wash with warm, soapy water and a clean cloth or sponge. Do not use a brush to clean this accessory as it may scratch the surface.
- Never use petroleum based solvents such as gasoline, thinner, or benzene to clean this accessory. Also do not use acid or alkaline cleaners.

INSTALLATION

1. Clean the surfaces of the front fender and the front cover of the vehicle with water where the fender flare will be installed. The mating surface must be clean, dry, and free of debris or contamination.
2. Hold left side (driver side) fender flare up against the front fender until it is fully seated.
3. Check to be sure there are no gaps between flare and body.
4. Use the fender flare as a template to mark the mounting locations with a marker. Be careful not to move the fender flare until all 10 holes are marked.

<LE Type shown>

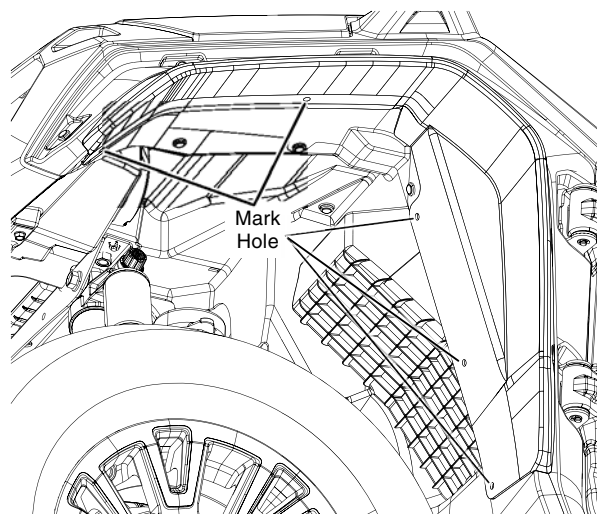

<LE Type Shown>

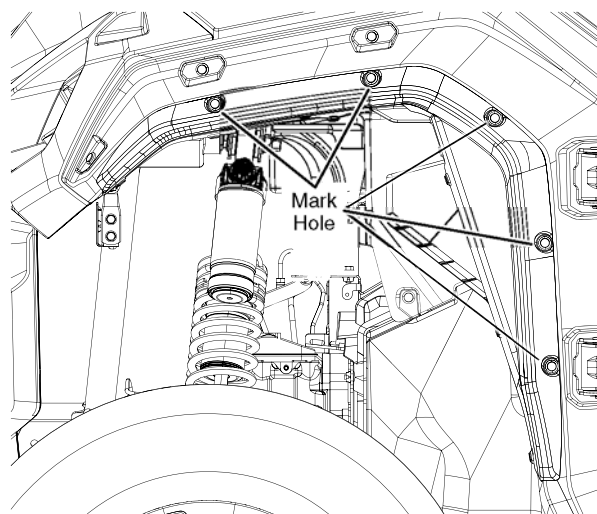

5. Once the hole locations are marked, remove the fender flare.

Using a power drill and 8 mm drill bit, drill a hole at each marked location.

6. Install the fender flare using the supplied trim clips.

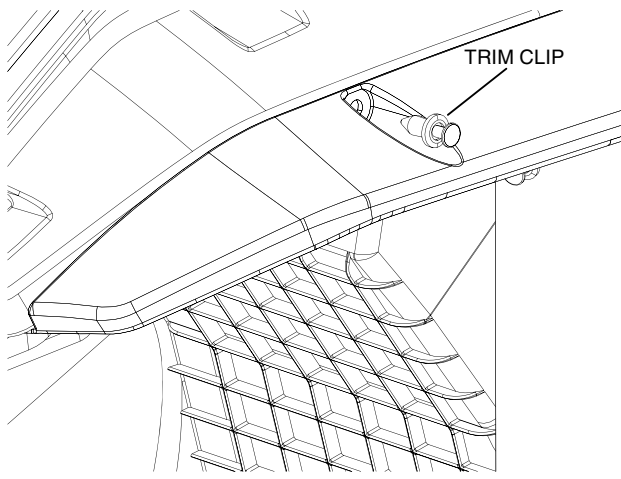

7. Repeat Steps 1 thru 5 for the right side (passenger side) fender flare.