



INSTALLATION INSTRUCTIONS

Accessory

CENTERSTAND
P/N 08M70-MKW-D00

Application

NC750XA/XD

Publication No.

MII 17714

Issue Date

April 2021

Honda Dealer: Please give a copy of these instructions to your customer.

PARTS LIST

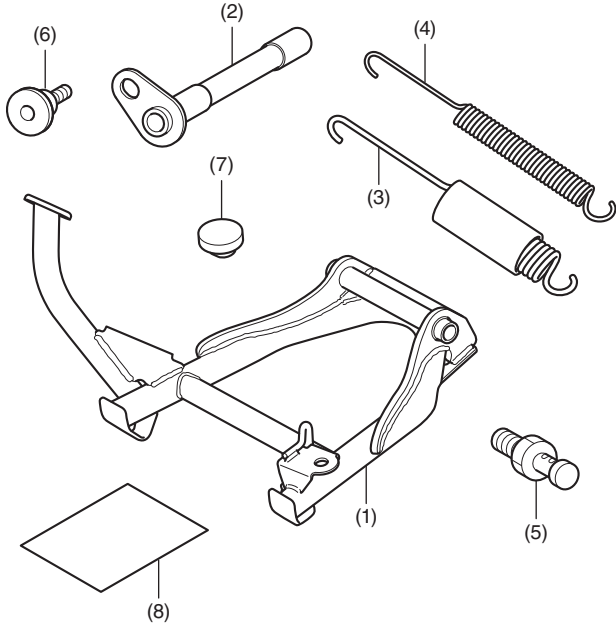

No.	Description	Qty
(1)	Center stand	1
(2)	Center stand shaft	1
(3)	Spring (wide)	1
(4)	Spring (narrow)	1
(5)	Spring hook	1
(6)	6 mm socket bolt	1
(7)	Rubber	1
(8)	Installation instructions	1

TOOLS AND SUPPLIES REQUIRED

Open-end wrench (12 mm)

Hex wrench (5 mm)

Spring tool (KL-9-C141)

Mild soap detergent solution

(Water : Soap / 100 : 1)

Grease

Shop towel

Torque wrench

TORQUE CHART

Tighten all screws, bolts, and nuts to their specified torque values. Refer to the Service Manual for the torque values of the removed parts.

Item	N·m	kgf·m	lbf·ft
6 mm socket bolt	12	1.2	9
Spring hook	22	2.2	16

INSTALLATION

▲ CAUTION

- To prevent burns, allow the engine, exhaust system, radiator, etc., to cool before installing the accessory.

NOTE:

- Be extremely careful when installing the springs as the combined tension of the springs is very strong.
- Keep the motorcycle on its side stand when installing the center stand.
- The spring installation should be performed by two people. While one person holds the motorcycle, another person installs the spring.

- Remove the parts as shown.

<Right side>

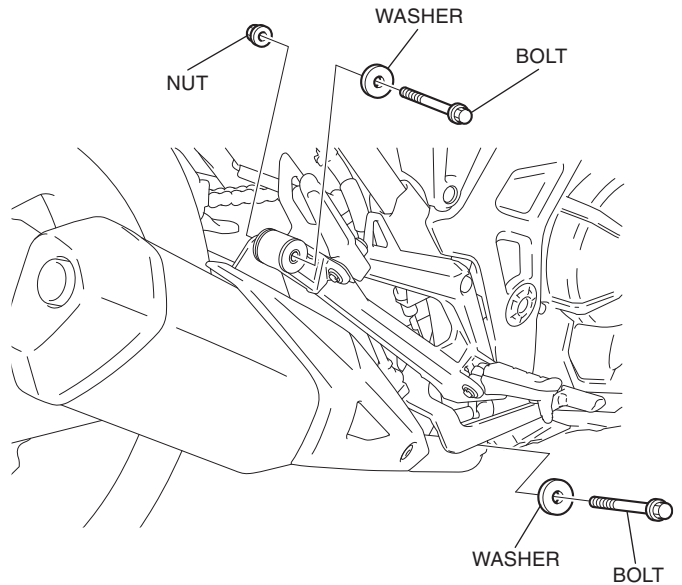

- Install the spring hook as shown.

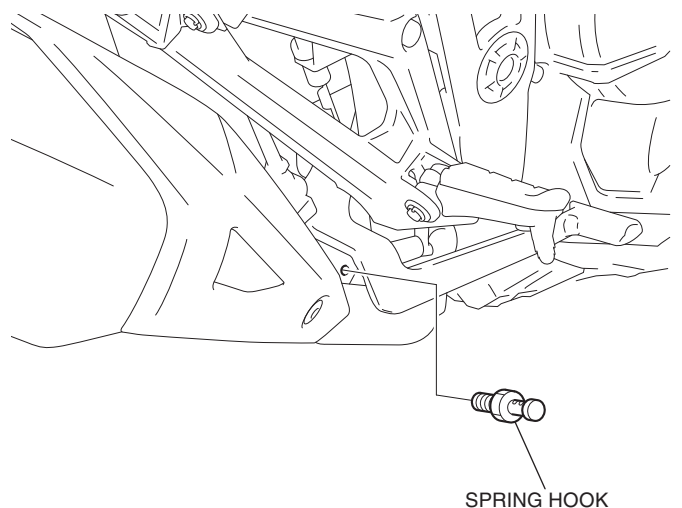

3. Install the removed parts in the reverse order of removal.
4. Apply mild soap detergent solution to the rubber in the area shown.

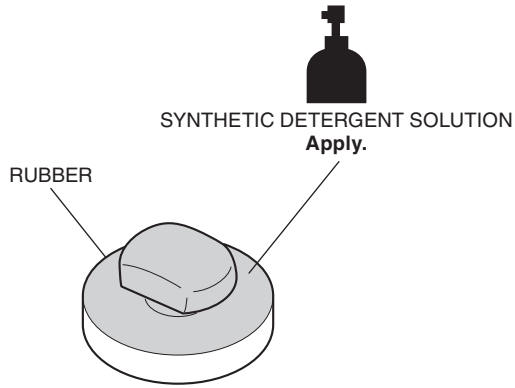

5. Install the rubber as shown.

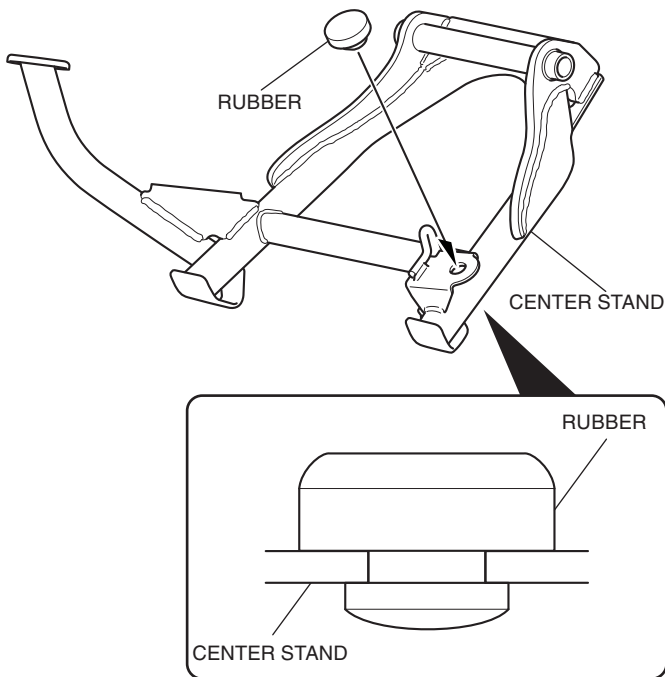

6. Apply grease to the position shown.

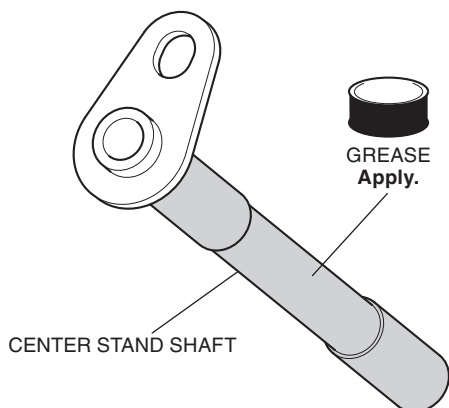

7. Install the center stand as shown.

<Left side>

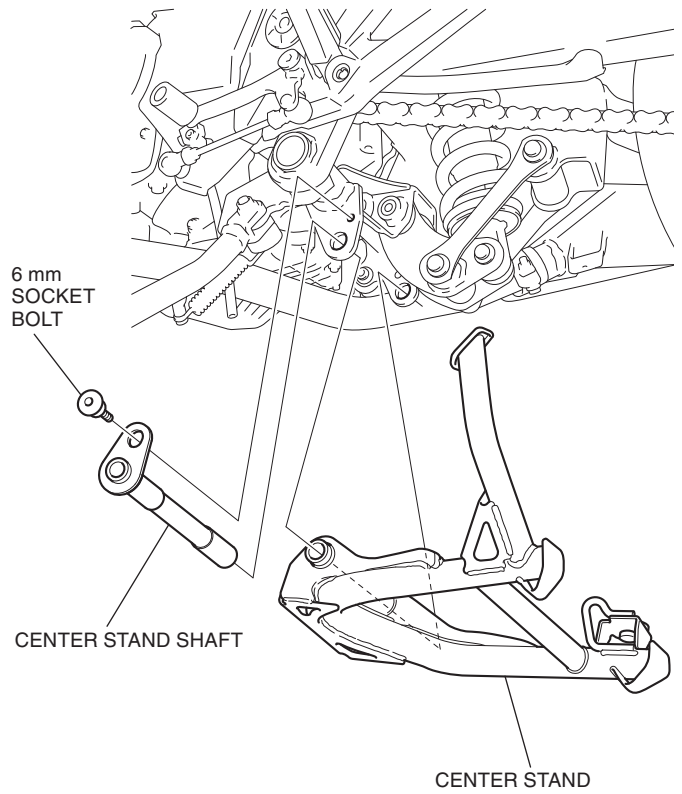

8. Slide the spring (narrow) into the spring (wide).

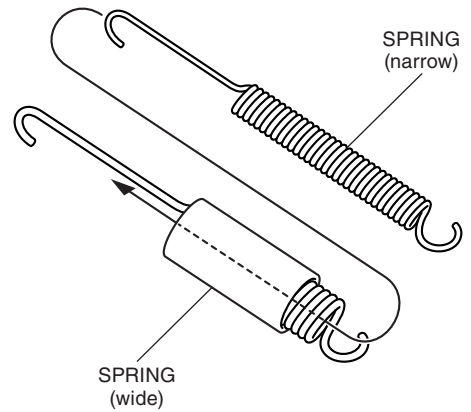

9. Install the spring assembly as shown.
- First install the spring assembly to the spring hook, then to the center stand.
 - The spring installation should be performed by two people. While one person holds the motorcycle, another person installs the spring.
 - For ease installation, first hook the spring (narrow).

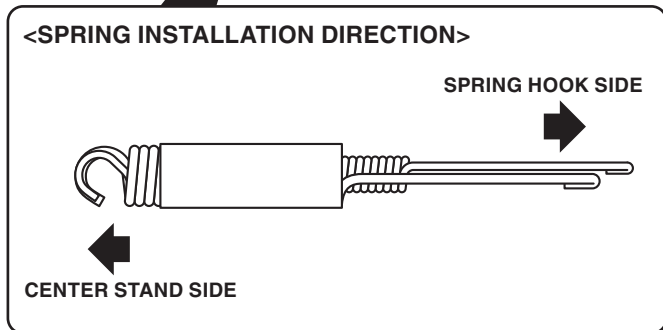
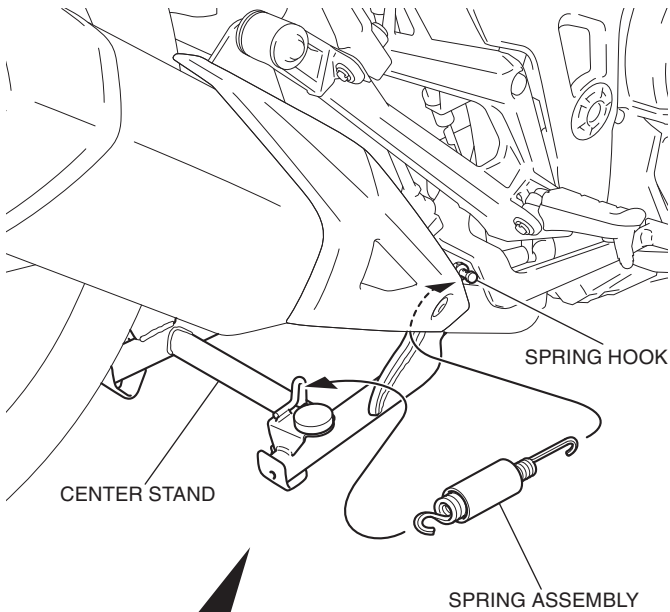

- If the spring assembly is too hard to install, remove the main stand shaft. First hook the spring assembly, then install the center stand shaft.

