

HONDA

INSTALLATION INSTRUCTIONS

Accessory	Application	Publication No.
CENTERSTAND P/N 08M70-MJP-G50 08M70-MJP-G51	CRF1000L/LD	MII 16887
		Issue Date REVISED October 2018

Honda Dealer: Please give a copy of these instructions to your customer.

PARTS LIST

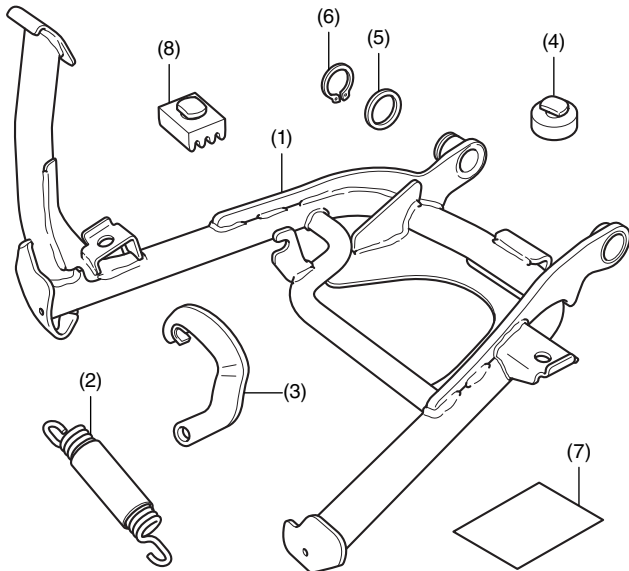

No.	Description	Qty
(1)	Centerstand	1
(2)	Spring	2
(3)	Spring plate	1
(4)	Stand rubber stop	1
(5)	Washer	1
(6)	Circlip	1
(7)	Installation instruction URL	1
(8)	Rubber Stop	1

SUPPLIES REQUIRED

- Snap ring pliers
- Spring tool
- Grease
- Synthetic detergent solution
(Water : Dish soap / 100 : 1)
- Shop towel

INSTALLATION

▲ CAUTION

- To prevent burns, allow the engine, exhaust system, radiator, etc., to cool before installing the accessory.

NOTE:

- Be extremely careful when installing the springs as the combined tension of the springs is very strong.
- Keep the motorcycle on its sidestand when installing the centerstand.
- The spring installation shall be performed by two persons. While one person holds the motorcycle, another person installs the spring.

- Apply synthetic detergent solution to the position shown.

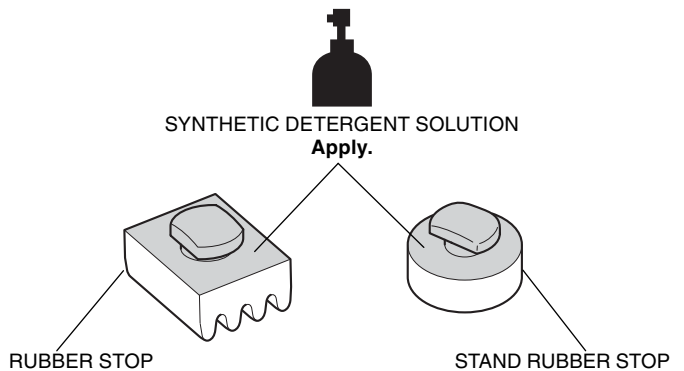

- Install the rubber stop in the positions shown.

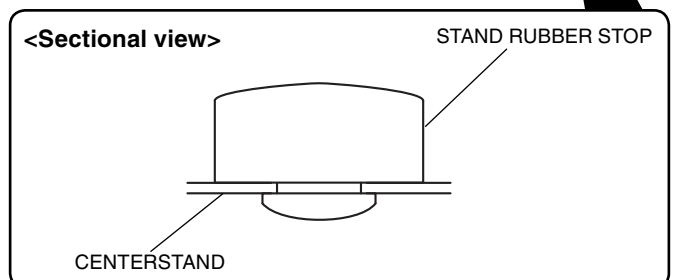
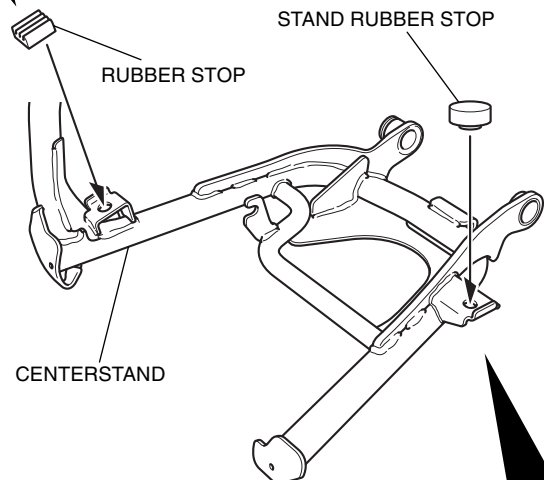
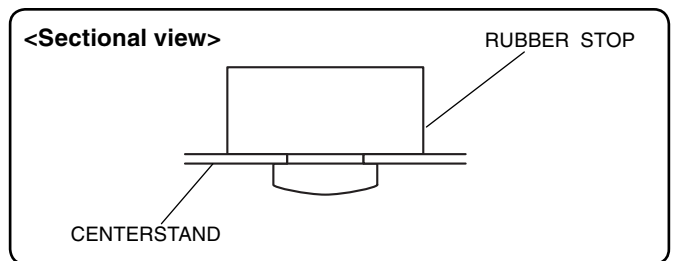

3. Apply grease to the positions shown.

<Right side>

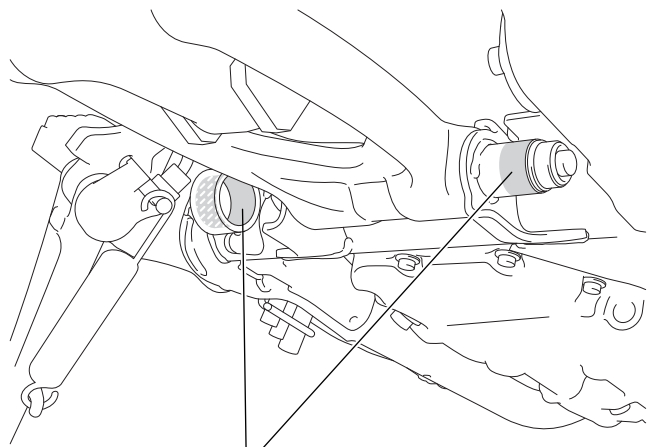

GREASE
Apply to the marked surfaces.

4. Apply grease to the position shown.

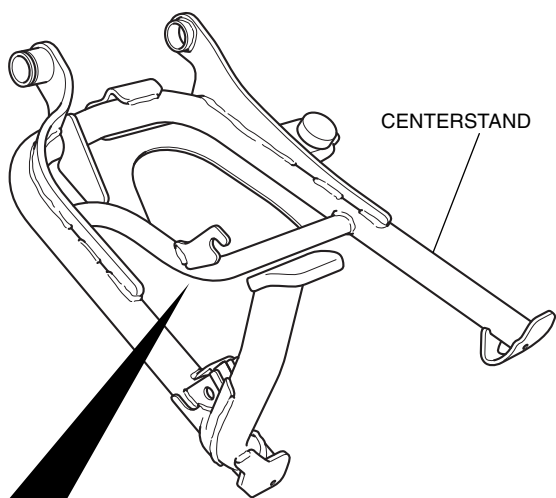

CENTERSTAND

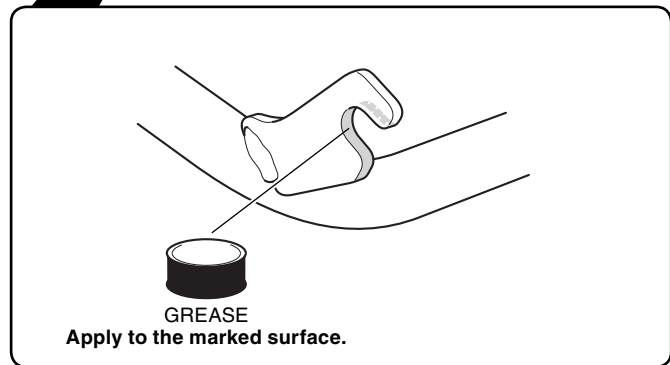

GREASE
Apply to the marked surface.

5. Install the centerstand as shown.

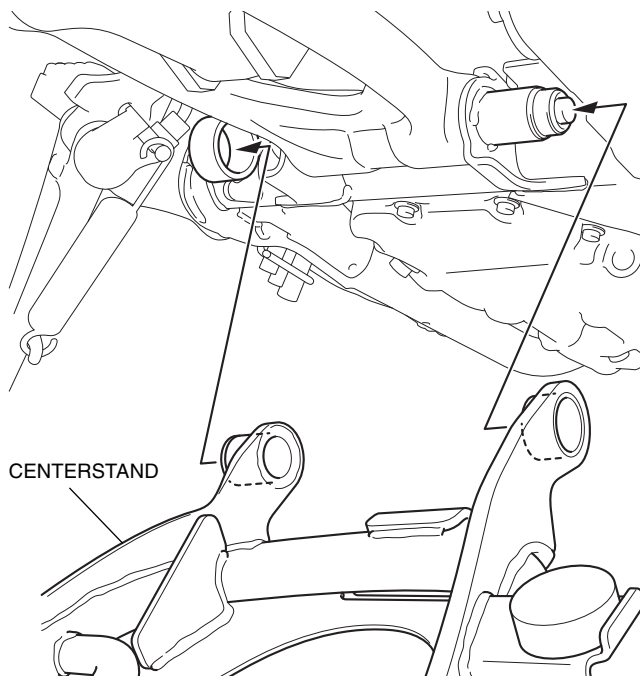

CENTERSTAND

6. Install the circlip and washer as shown.

<Left side>

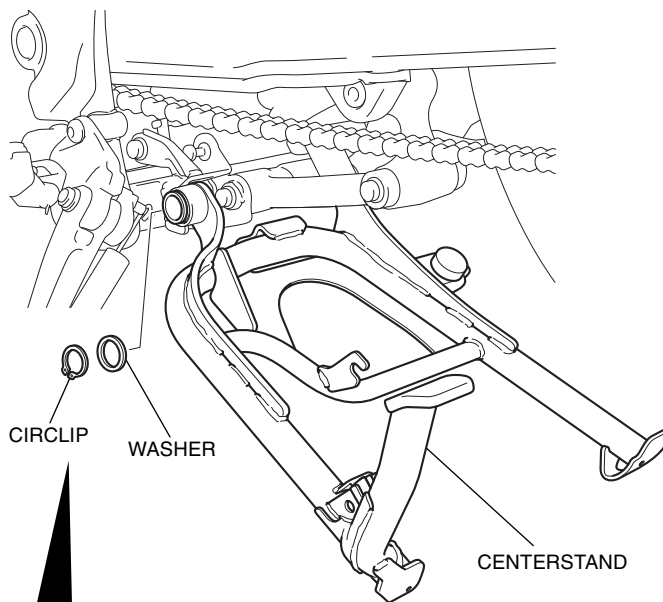

CIRCLIP
WASHER

CENTERSTAND

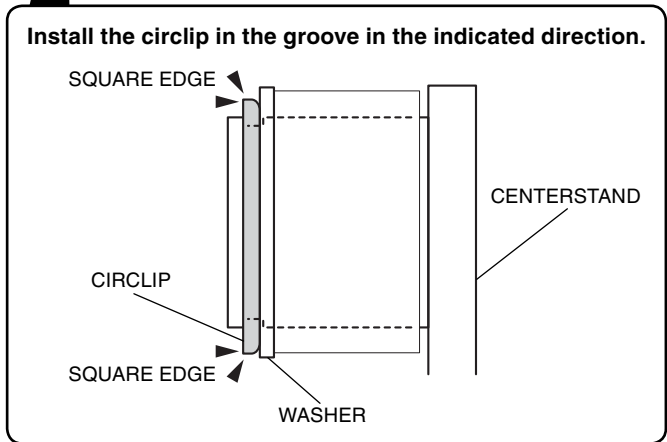

Install the circlip in the groove in the indicated direction.

SQUARE EDGE

CIRCLIP

SQUARE EDGE

WASHER

CENTERSTAND

7. Apply grease to the positions shown.

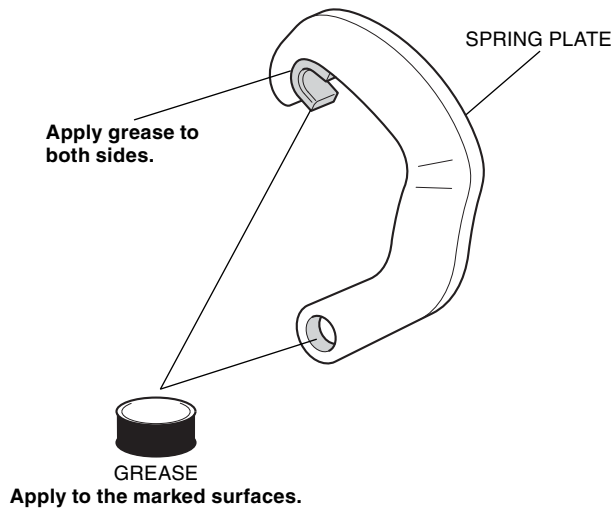

8. Install the springs to the spring plate as shown.

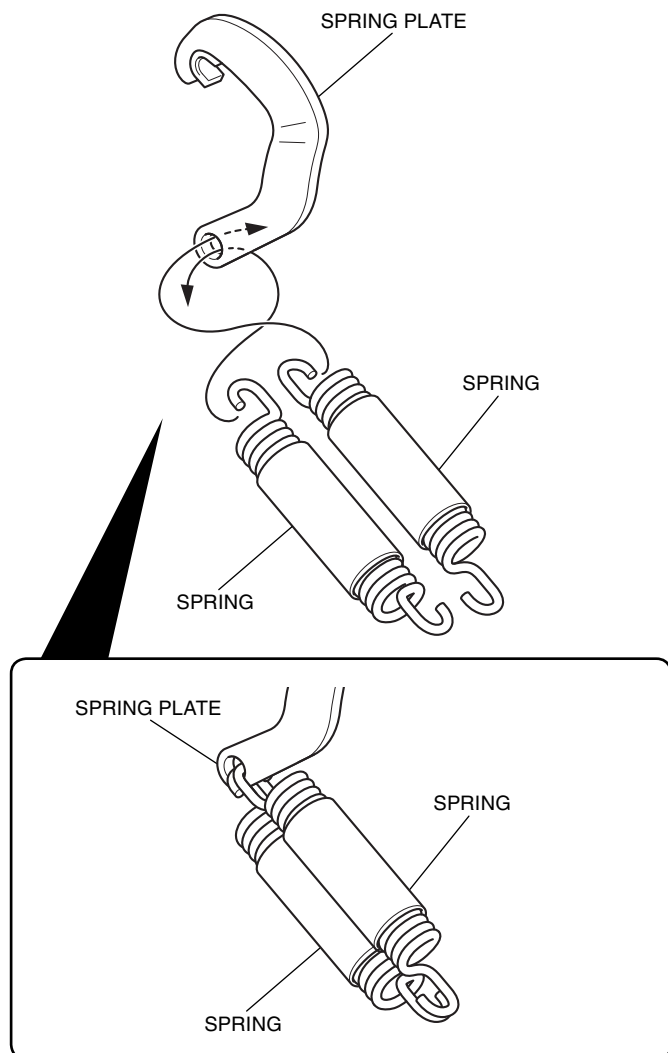

9. Apply grease to the position shown.

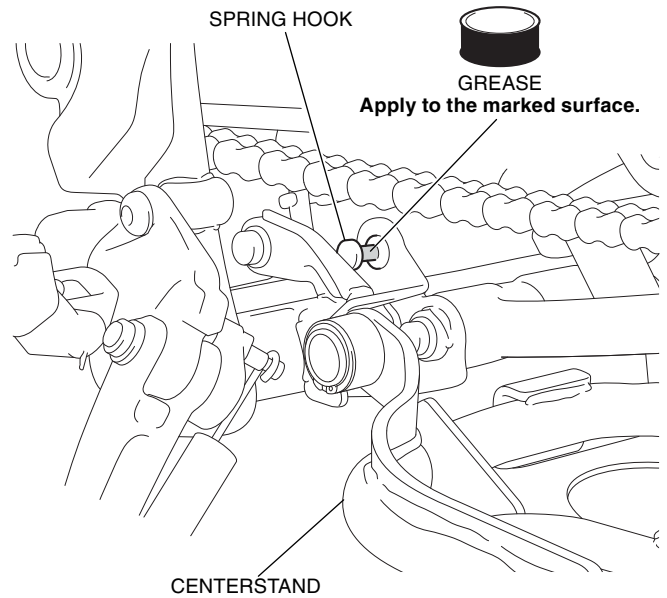

10. Install the spring plate as shown.

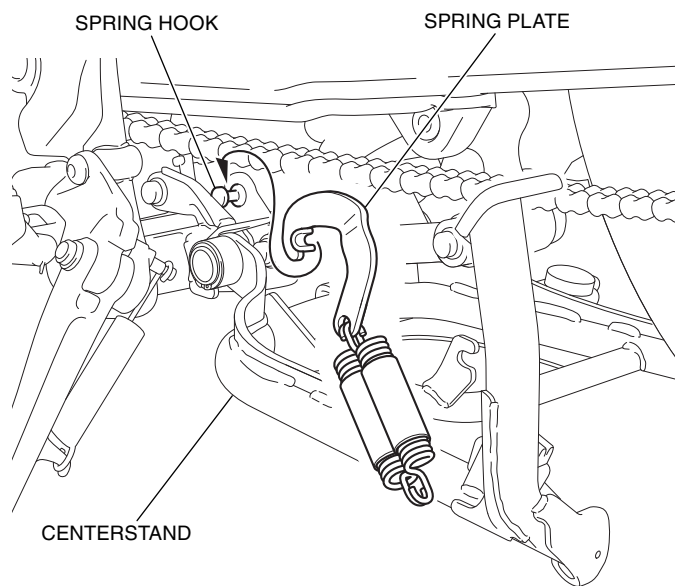

11. Install the springs as shown.

- **The spring installation shall be performed by two persons. While one person holds the motorcycle, another person installs the springs.**

