

PARTS LIST

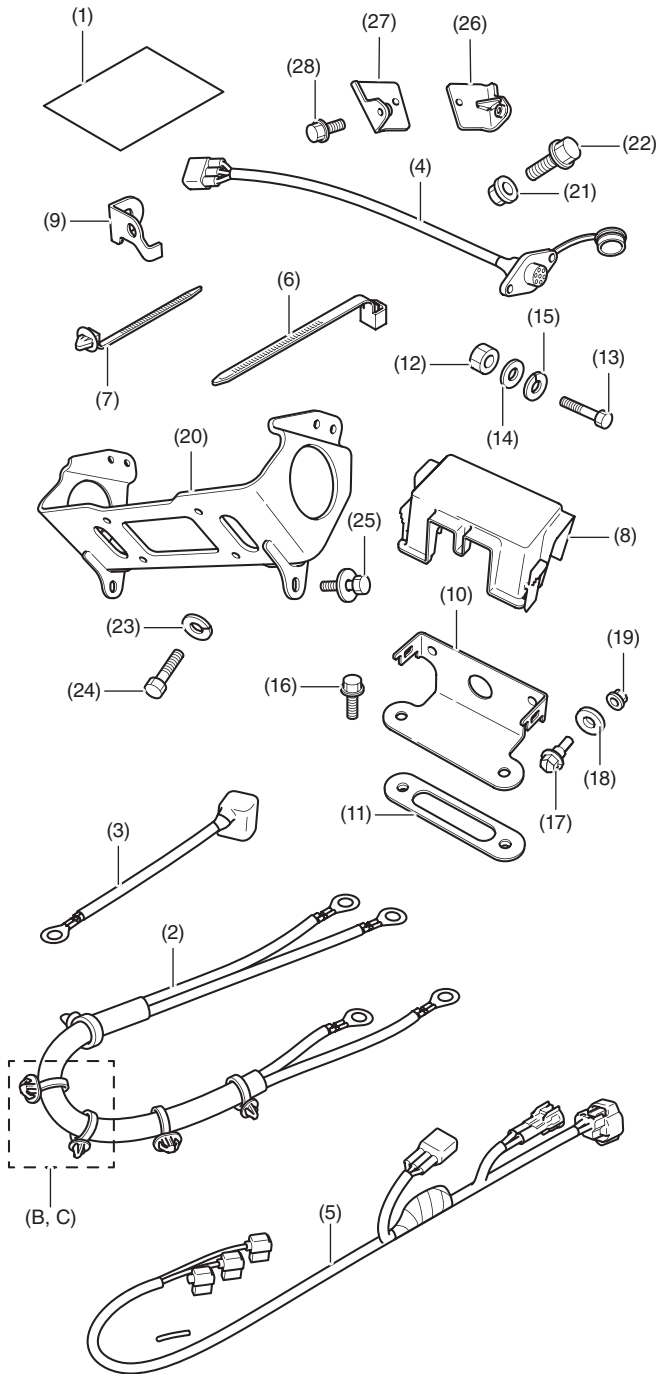

No.	Description	Qty
(1)	Installation Instructions URL	1
(2)	Winch power cables*	1
(3)	Winch battery cable	1
(4)	Remote control sub harness	1
(5)	Winch sub harness	1
(6)	Wire tie	19
(7)	Clip band	1
(8)	Contactor cover	1
(9)	Harness clip stay	1
(10)	Contactor stay	1
(11)	Contactor plate nut	1
(12)	5 mm nut	2
(13)	5 mm bolt	2
(14)	Washer	2
(15)	Lock washer (small)	2
(16)	6 mm flange bolt	2
(17)	5 mm shoulder bolt	2
(18)	Rubber washer	2
(19)	5 mm flange nut	2
(20)	Winch bracket	1
(21)	10 mm flange nut	2
(22)	10 mm flange bolt	2
(23)	Lock washer (large)	4
(24)	8 mm bolt	4
(25)	10 mm bolt washer	2
(26)	Right roller bracket	1
(27)	Left roller bracket	1
(28)	8 mm flange bolt	2

*Some winch power cables will have five clip bands; updated cables will have only three clip bands.

- If your winch power cables have five clip bands, bands B and C (indicated in the illustration), will not be used for installation.

WINCH
Sold Separately P/N 08L71-HL3-A41

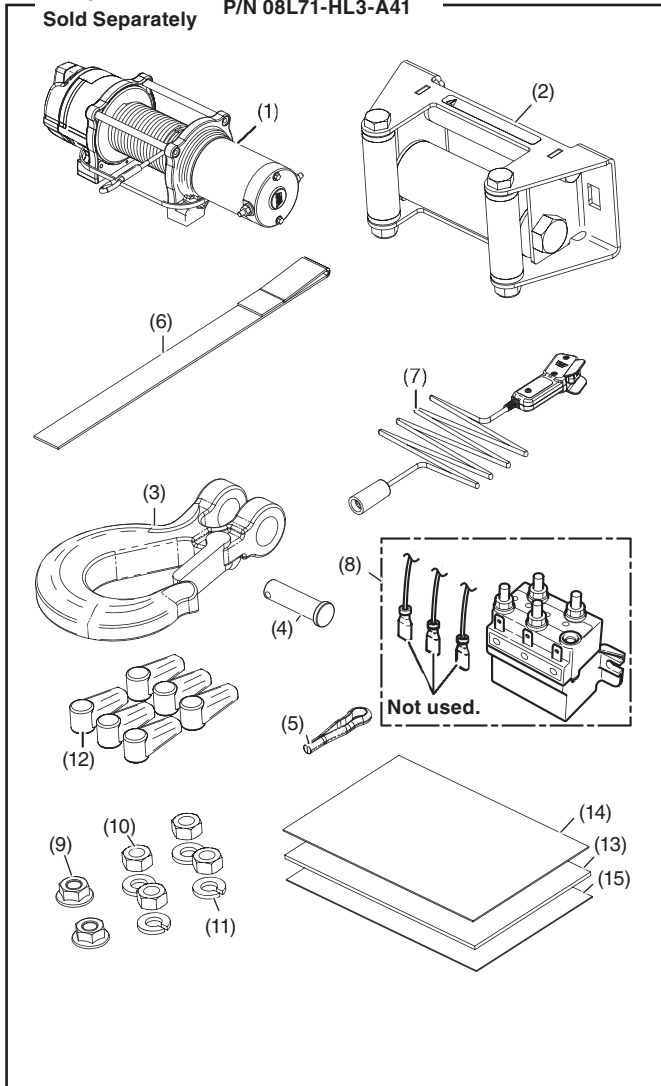

No.	Description	Qty
(1)	Winch	1
(2)	Roller fairlead	1
(3)	Hook	1
(4)	Clevis pin	1
(5)	Cotter pin	1
(6)	Strap	1
(7)	Remote control switch	1
(8)	Contactors (with unused wires)	1
(9)	6 mm flange nut	2
(10)	6 mm nut	4
(11)	Lock washer	4
(12)	Terminal boot	6
(13)	Winching ATV NGW Guide	1
(14)	Winch PV4500 Spec Sheet	1
(15)	Limited Lifetime Warranty	1

WINCH
Sold Separately P/N 08L71-HL3-A43

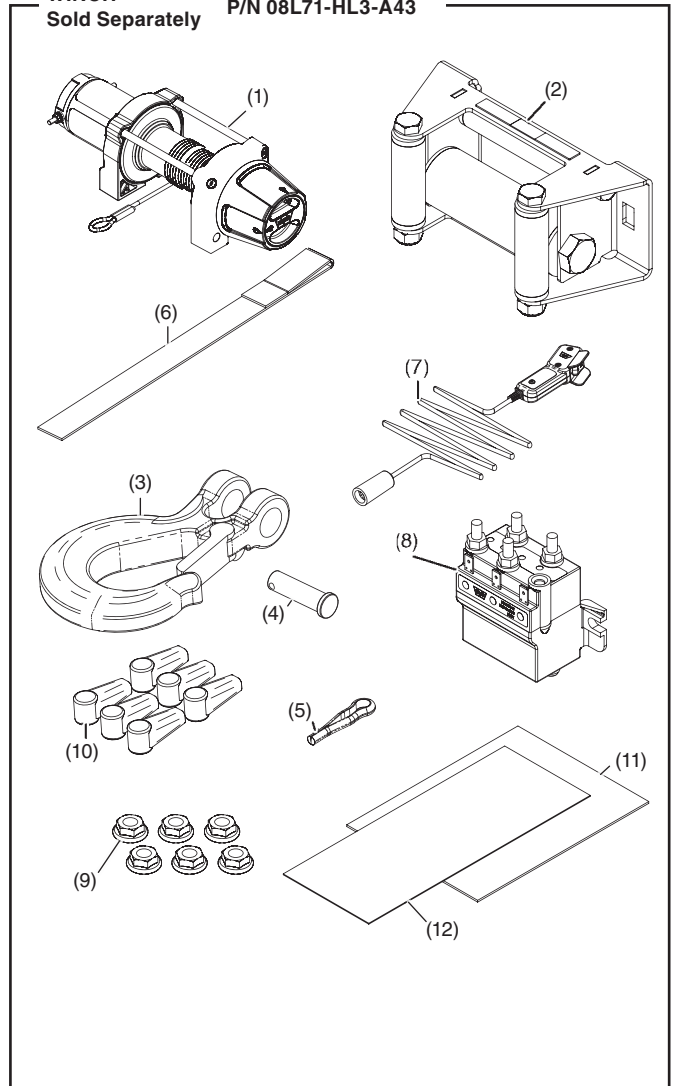

No.	Description	Qty
(1)	Winch	1
(2)	Roller fairlead	1
(3)	Hook	1
(4)	Clevis pin	1
(5)	Cotter pin	1
(6)	Strap	1
(7)	Remote control switch	1
(8)	Contactors	1
(9)	6 mm flange nut	6
(10)	Terminal Boot	6
(11)	VRX Axon Product Literature	1
(12)	Conform CE Declaration	1

CUSTOMER INFORMATION:

The information in these installation instructions is intended for use only by skilled technicians who have the proper tools, equipment, and training to correctly and safely add equipment to your SxS. These procedures should not be attempted by “Do-it-yourselfers.”

BEFORE YOU BEGIN

This kit describes the installation of a WARN SxS winch. Please read WARN’s Winching Technique guide provided with the winch prior to use of this product.

TOOLS AND SUPPLIES REQUIRED

Socket (8, 10, 12 and 14 mm)

Ratchet

Box-end wrench (8, 10 and 14 mm)

Side cutters

Electric drill

Drill bit (5 and 7 mm)

Holesaw (18 mm)

Marker

Ruler

Electrical tape

Scissors

Wire or Wire tie (Length: 290 mm or more/Width: 5 mm)

Torque wrench

TORQUE CHART

Tighten all screws, bolts, and nuts to their specified torque values. Refer to the Service Manual for the torque values of the removed parts.

Item	N-m	kgf-m	lbf-ft
5 mm bolt and nut	5.2	0.5	3.8
5 mm flange nut	5.2	0.5	3.8
6 mm nut	10	1.0	7
6 mm flange bolt and nut	12	1.2	9
8 mm bolt	22	2.2	16
8 mm flange bolt	27	2.8	20
10 mm flange nut	39	4.0	29
10 mm bolt washer	50	5.1	37

MAXIMUM WINCH CAPACITY

Winch Capacity	4,500 lb (2,041 kg)
----------------	---------------------

SAFETY

When installing your SxS winch system, read and follow all mounting and safety instructions. Always use caution when working with electricity and verify that there are no exposed electrical connections before energizing your winch circuit. For specifications and performance data, refer to the specification sheet supplied with your winch.

INSTALLATION

▲ CAUTION

- To prevent burns, allow the engine, exhaust system, radiator, etc., to cool before installing the accessory.

NOTE:

- Disconnect the battery negative (-) cable before installing this accessory.
- The memory of the clock will be erased when you disconnect the battery. Reset the clock after reconnecting the battery.
- Cut the wire ties at 5 mm from the lock part after attaching them to the wire harnesses. Do not allow the cut part of the wire tie to interfere with another harness or brake hose.
- Reinstall the removed parts on the vehicle and make sure that the wires and harnesses are not pinched.
- Always perform the heavy installation work with two people.
- For installation of this accessory on a SxS equipped with a horn, refer to the installation instructions included with the horn mount.

1. Remove the vehicle's parts as shown.

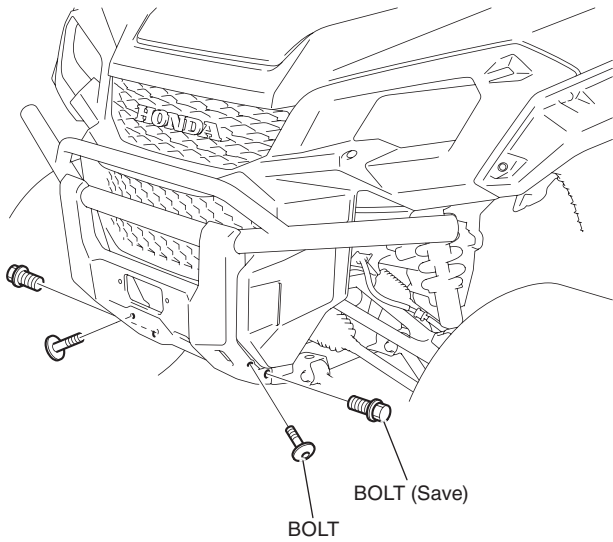

2. Remove the front bumper as shown.

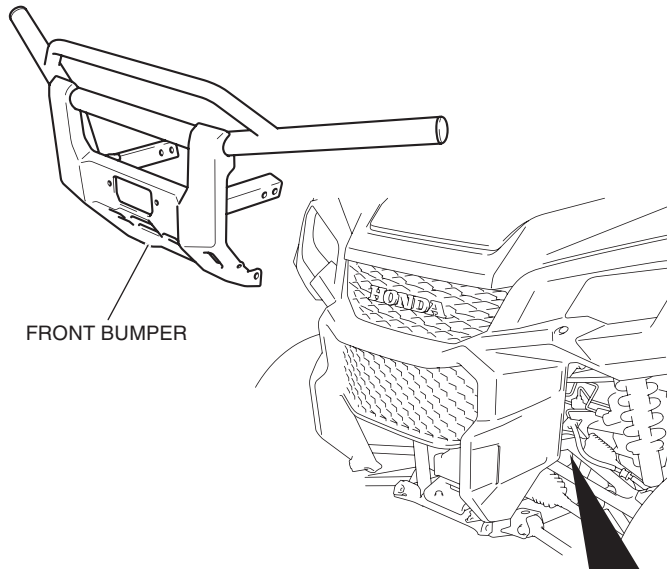

Remove the bolts as shown.

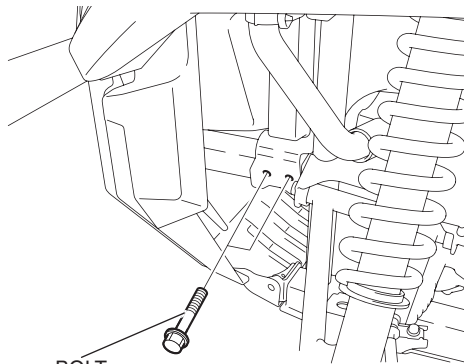

Repeat on the right side.

3. Remove the front hood as shown.

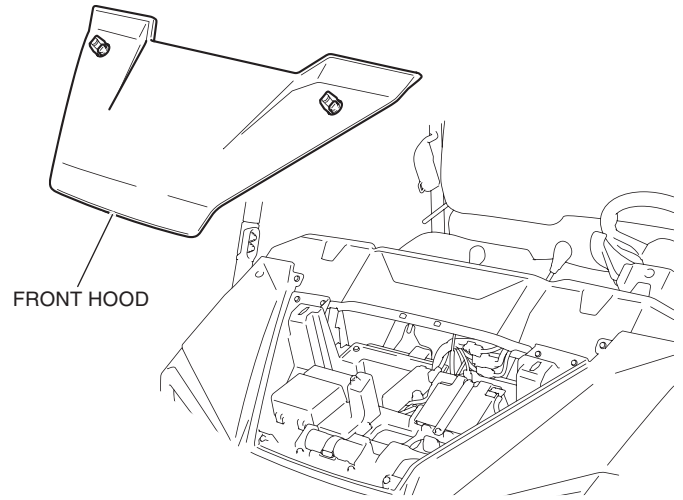

4. Loosely install the right and left roller bracket to the front bumper as shown.

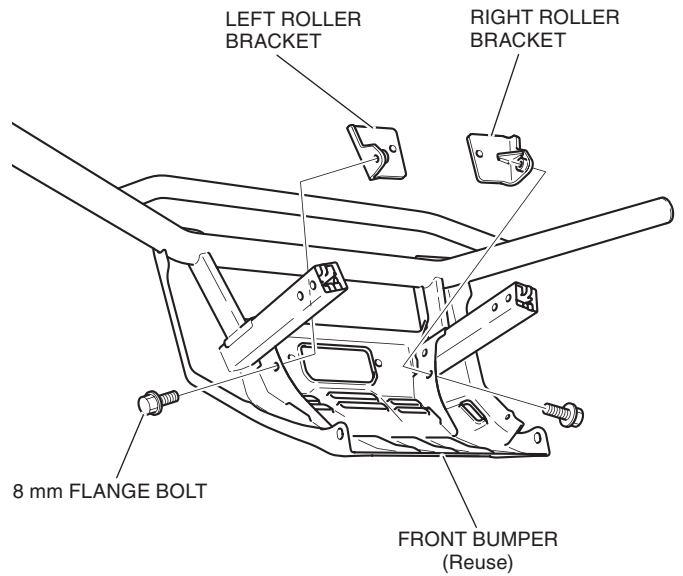

5. Install the roller fairlead as shown.

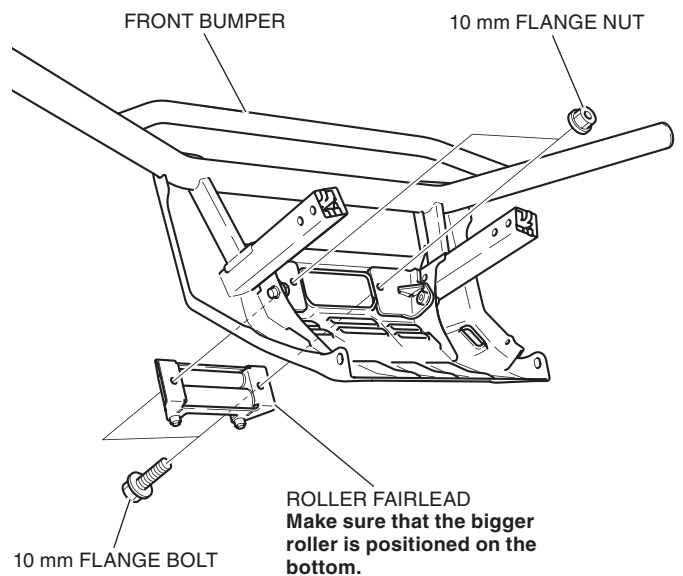

6. Tighten the loosely installed parts securely.
7. Drill an 18 mm hole into the instrument panel as shown.
 - Drill hole at the center of the marked line.
 - Remove any burrs from the edge of the hole.

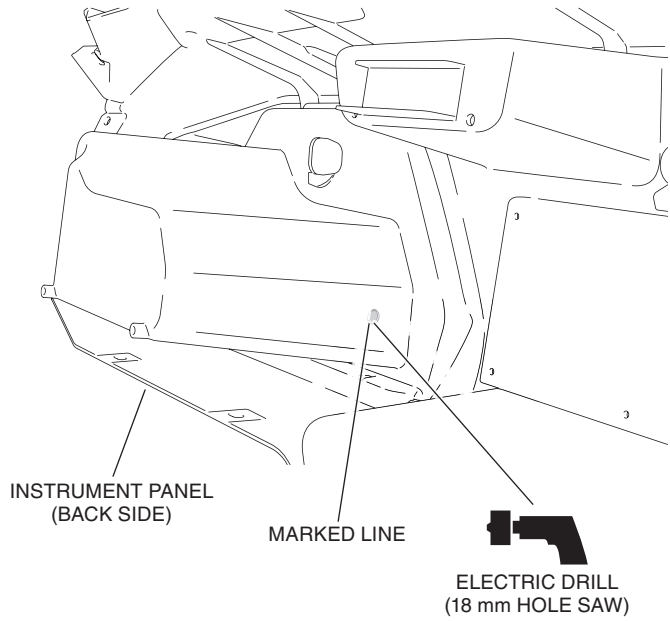

8. Position the remote control sub harness as shown and mark this position.

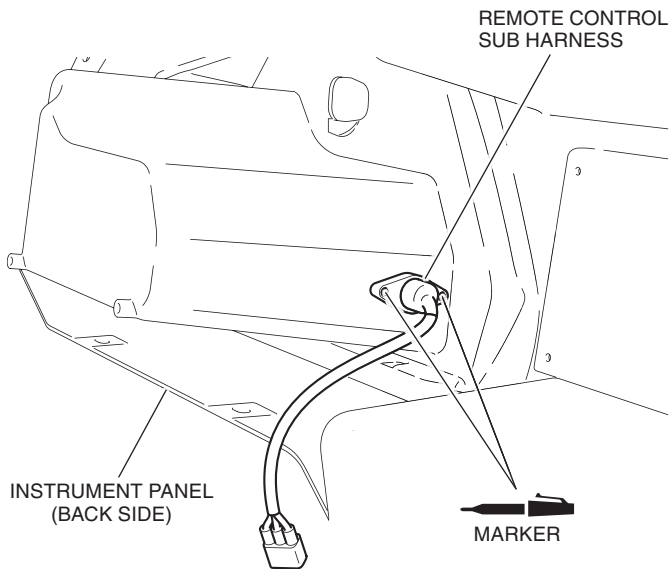

9. Remove the remote control sub harness and drill at the marked point on the instrument panel using an electric drill.
 - Remove any burrs from the edge of the hole.

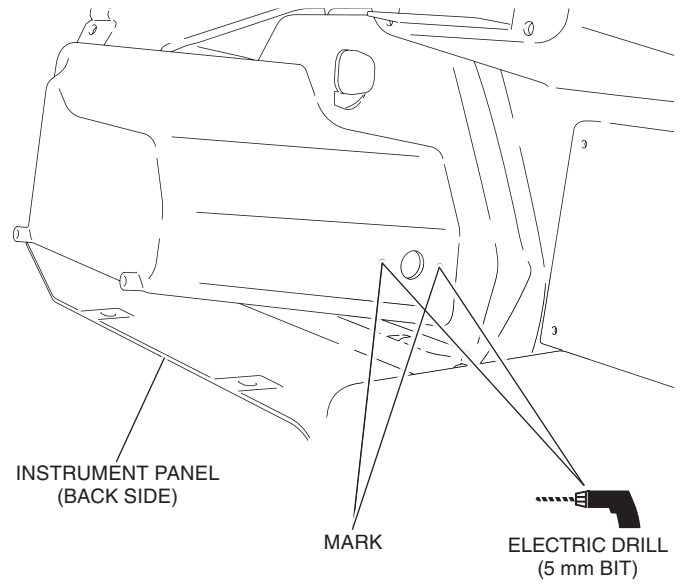

10. Open the glove box and pass the remote control sub harness through the hole in the instrument panel.

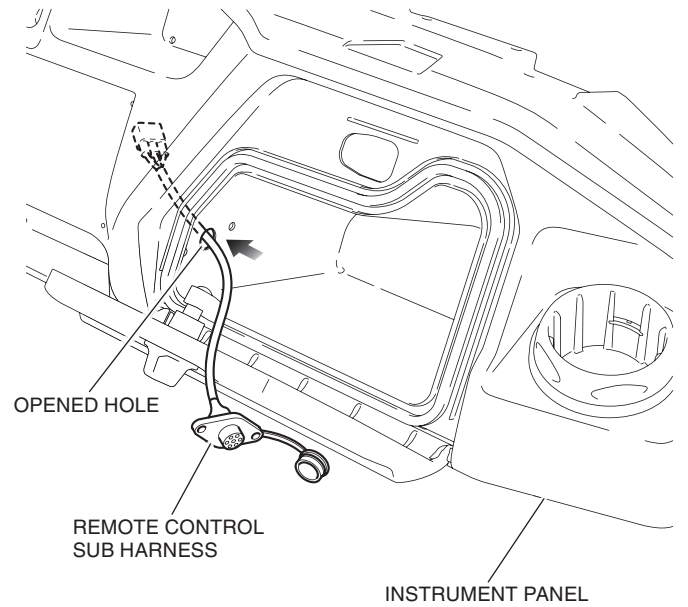

11. Install the remote control sub harness as shown.

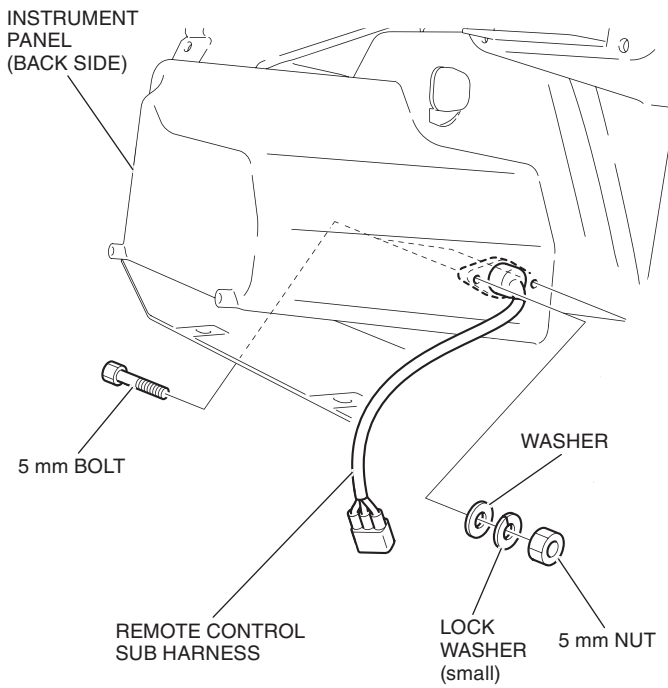

12. Drill holes into the front fender as shown.

- **Drill holes at the center of the marked lines.**
- **Remove any burrs from the edge of the hole.**
- **Be careful not to damage the harness.**

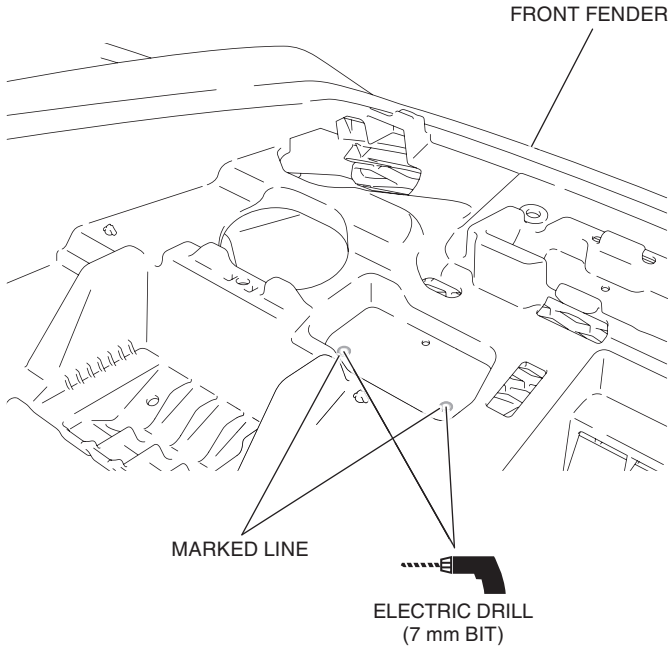

13. Install the contactor to the contactor stay as shown.

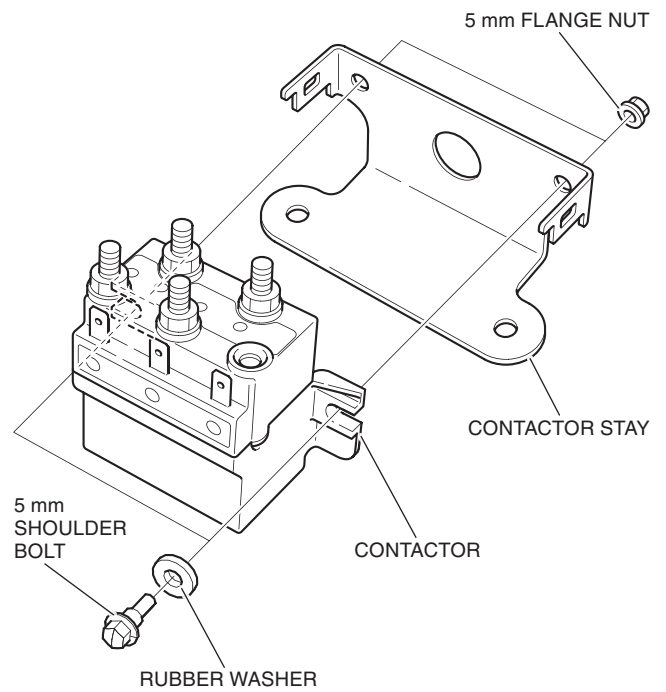

14. Install the assembled contactor to the front fender as shown.

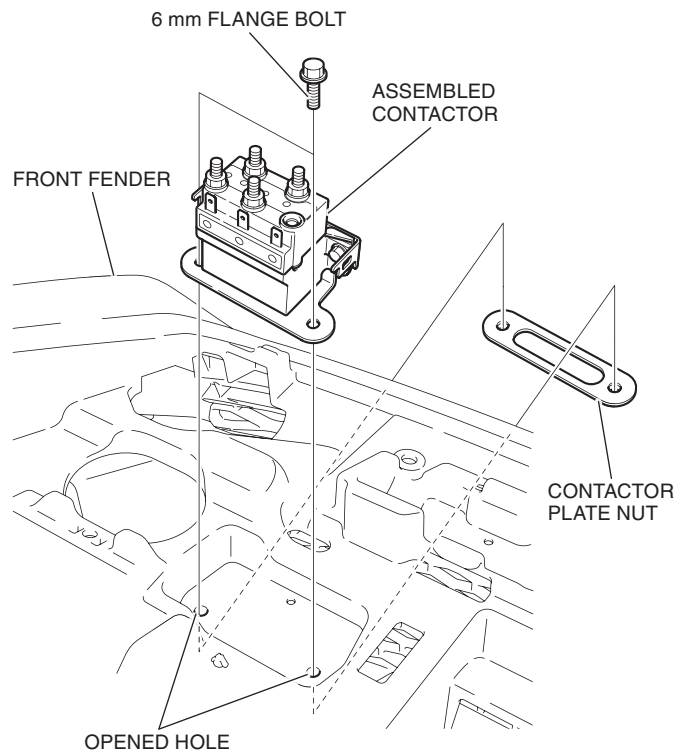

15. Route and connect the winch sub harness to the accessory socket as shown.

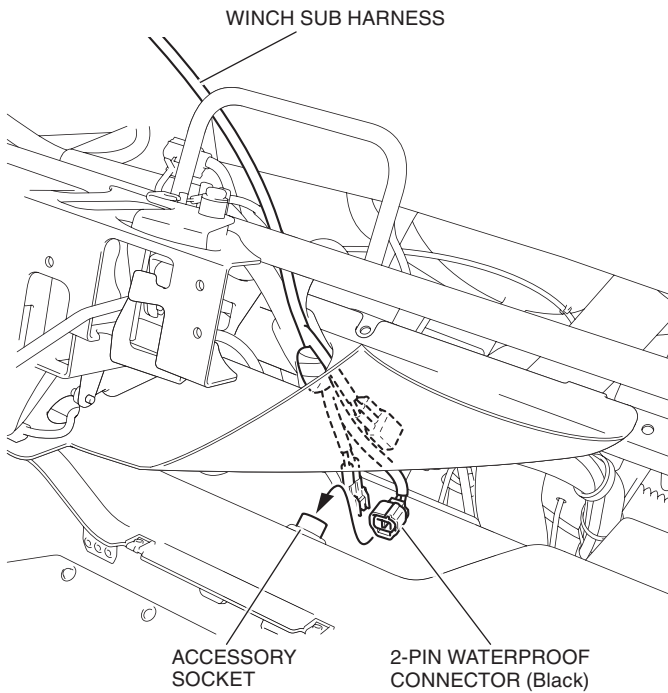

16. Connect the vehicle's harness to the winch sub harness as shown.

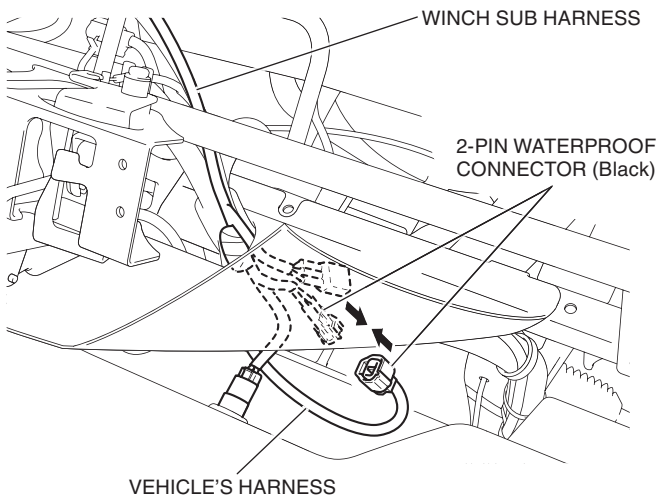

When also installing the Horn mount:

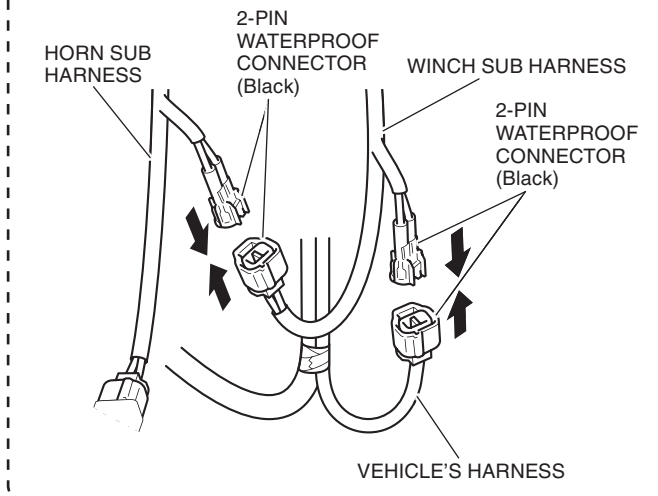

17. Secure the winch sub harness with the wire tie as shown.

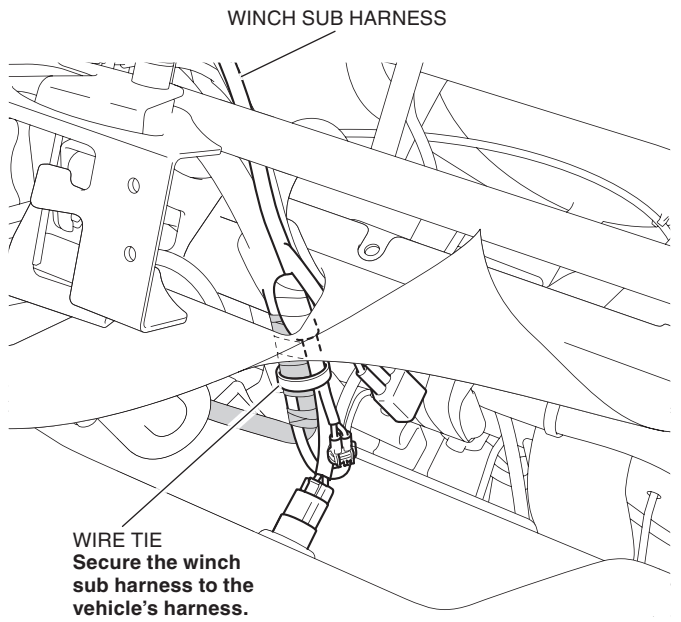

18. Connect the winch sub harness and remote control sub harness as shown.

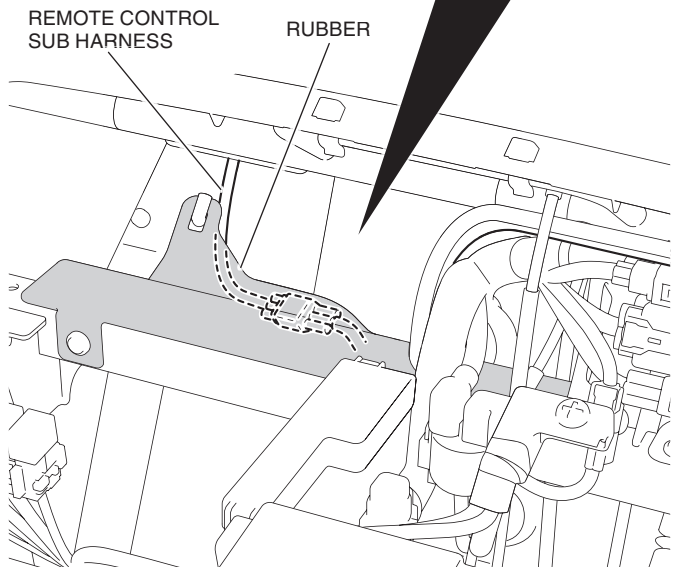
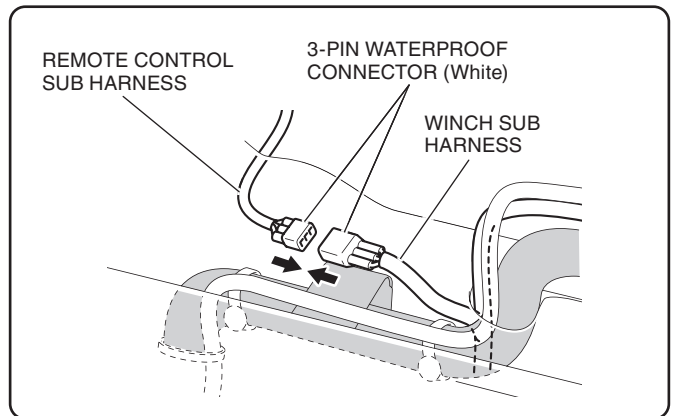

19. Secure the harnesses with the wire ties as shown.

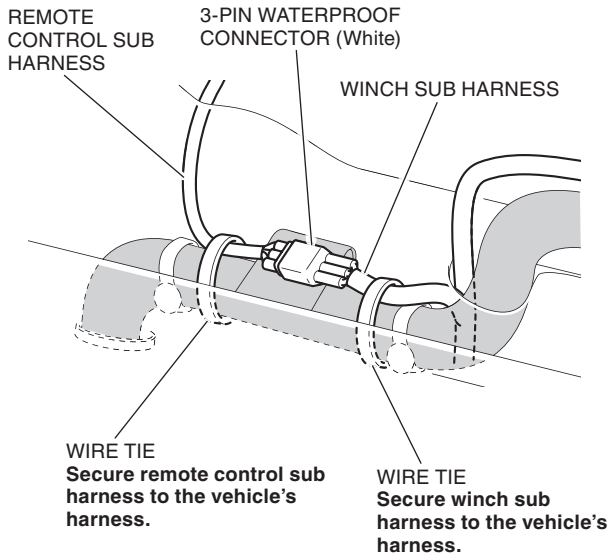

20. Remove the bolt as shown.
<Right side>

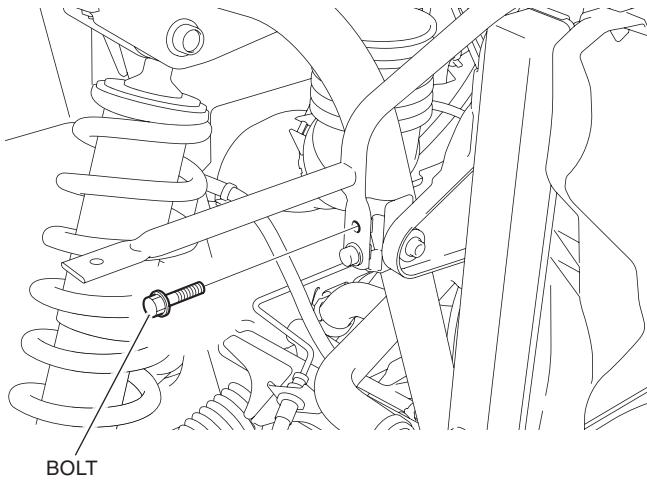

21. Install the harness clip stay as shown.

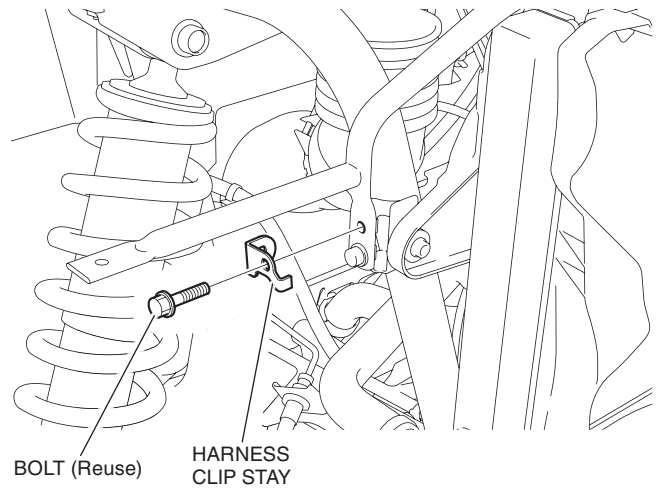

When also installing the Horn mount:

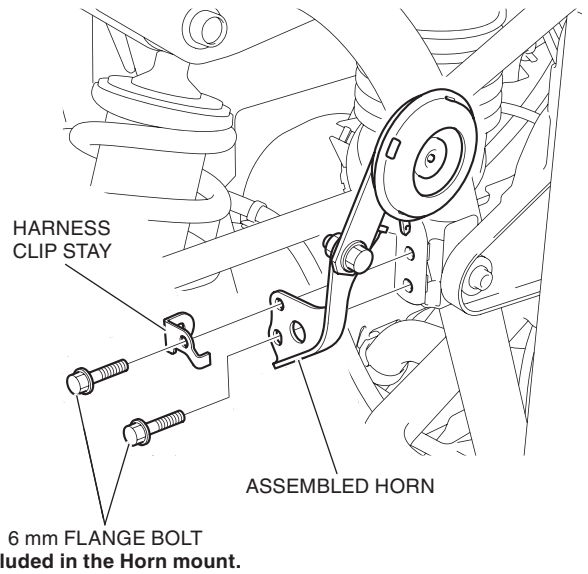

22. Install the winch power cables as shown.

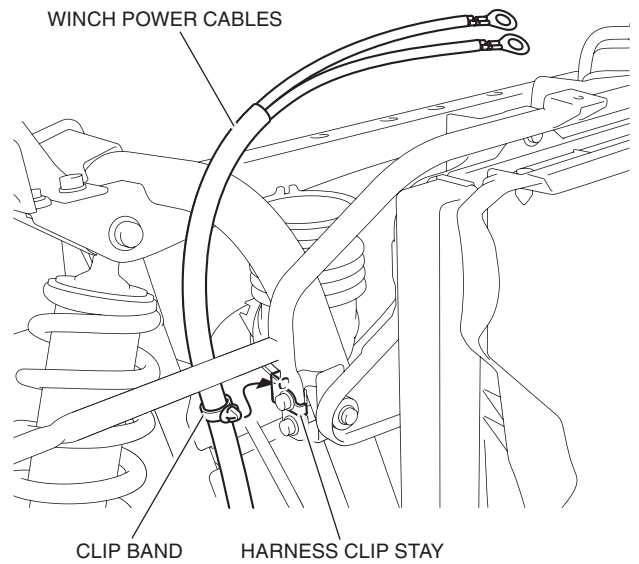

23. Secure the winch power cables with the wire tie as shown.

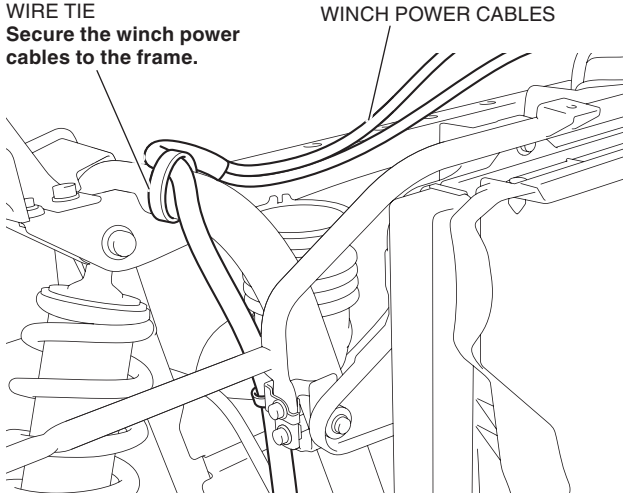

24. Remove the coolant reserve tank from the stay by pulling it up while leaving the hoses connected. Set the reserve tank to the side.

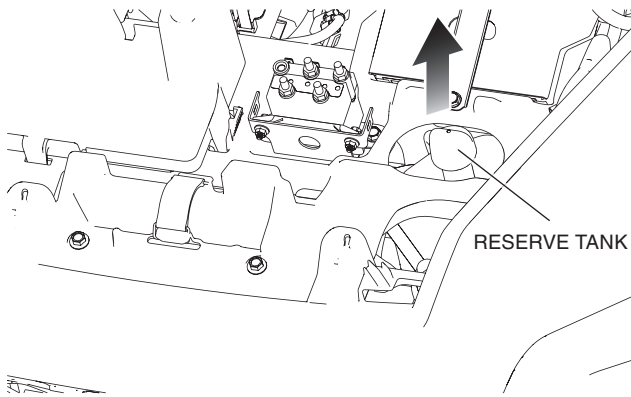

25. Route the winch power cables along the frame under the front panel. Secure the winch power cables with the wire ties as shown.

- Front Fender not shown for clarity.

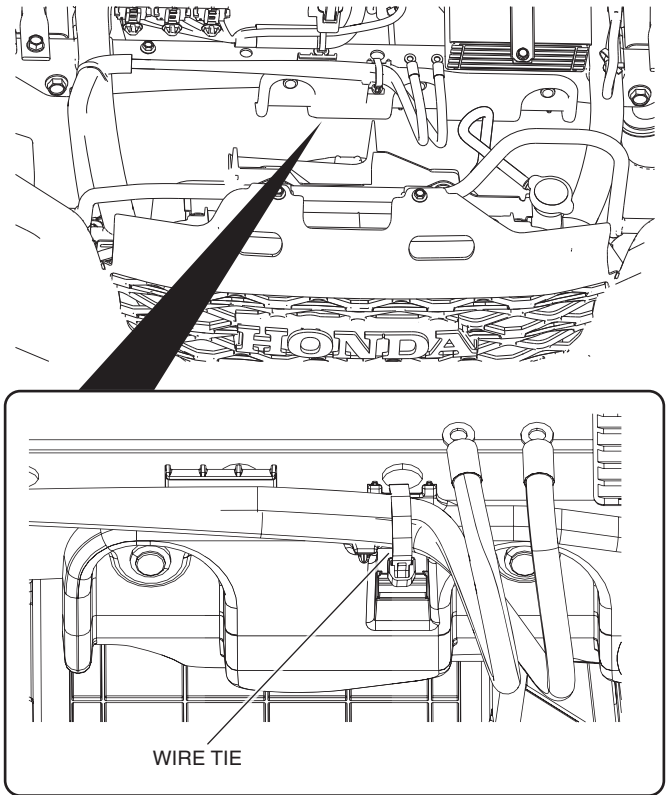

26. Reinstall the coolant reserve tank in the reverse order of removal.

27. Route the winch power cables and secure them with the wire tie as shown.

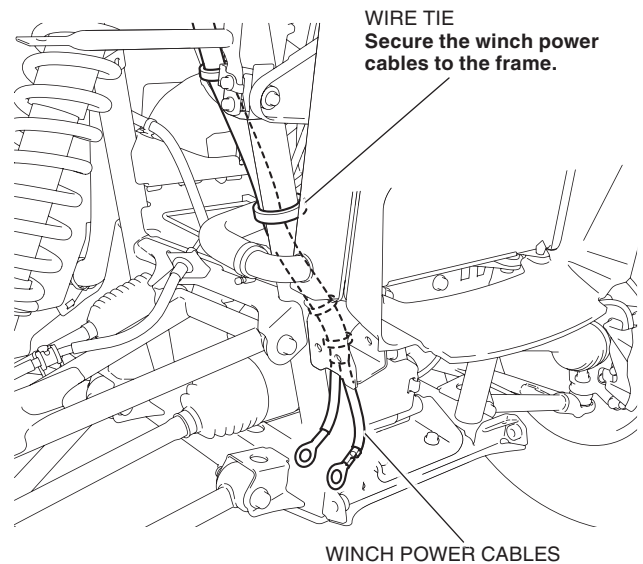

28. Install the winch power cables as shown.

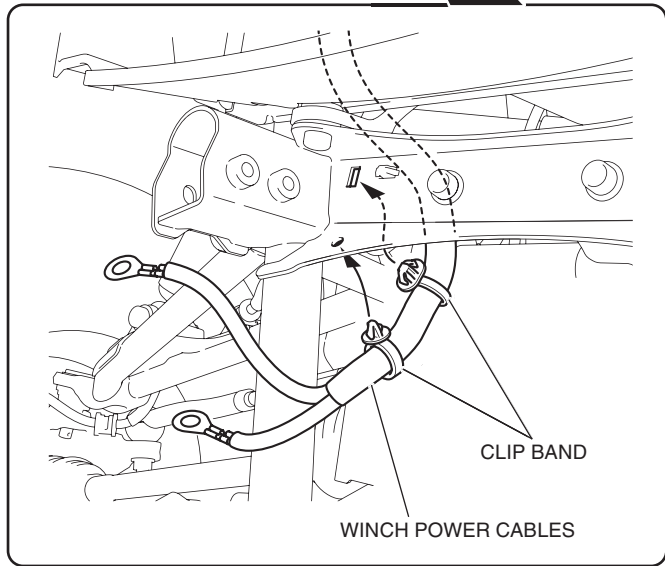
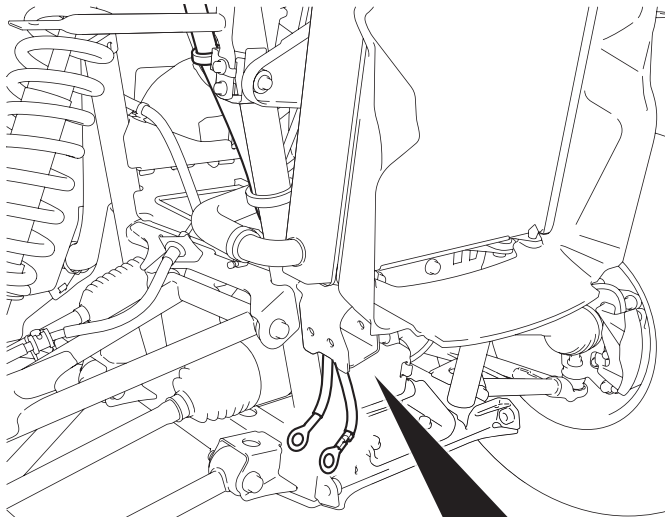

29. Install the terminal boots as shown.

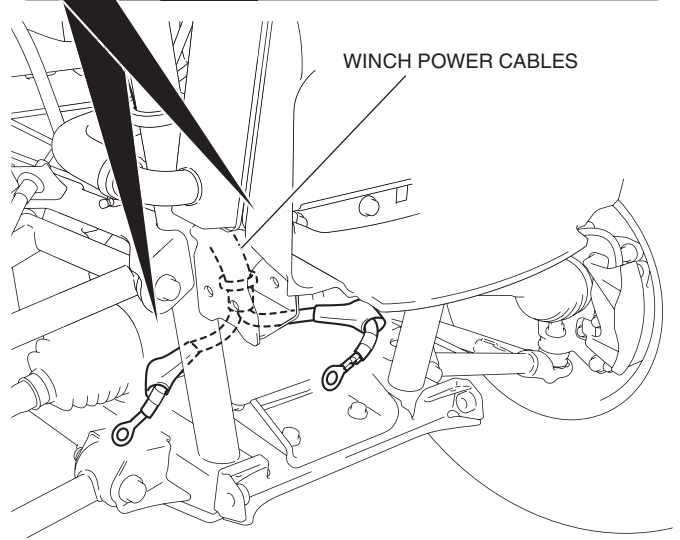
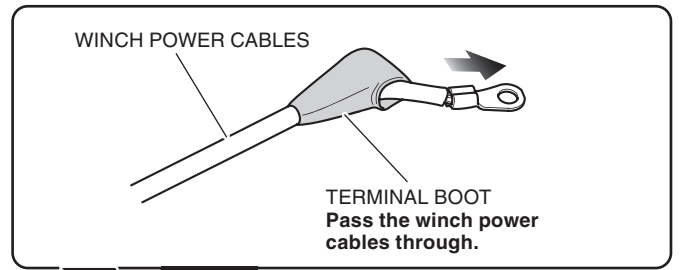

30. Remove the wire tie as shown.

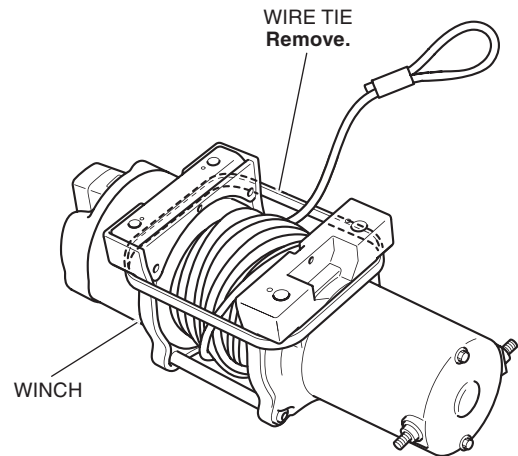

31. Install the winch to the winch bracket as shown.

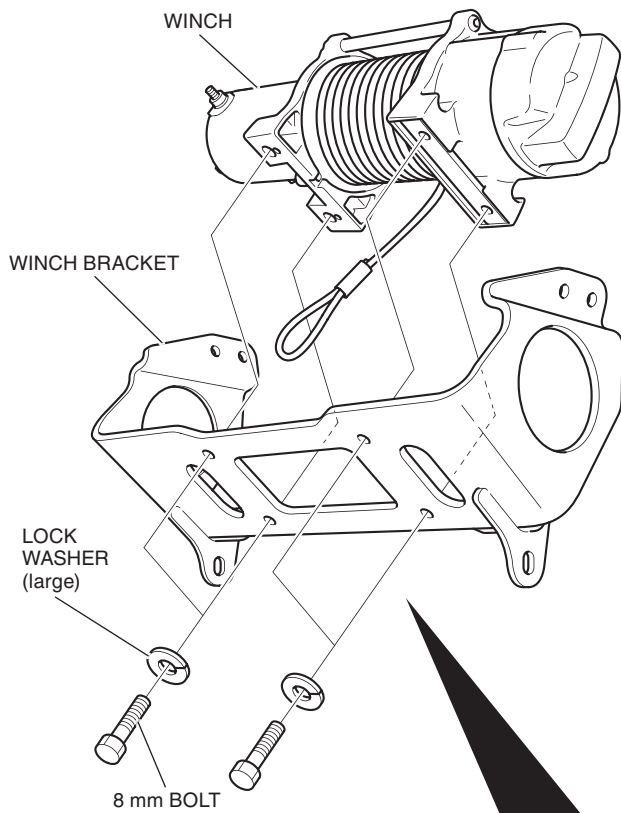

Pull out the wire over the bracket as shown.

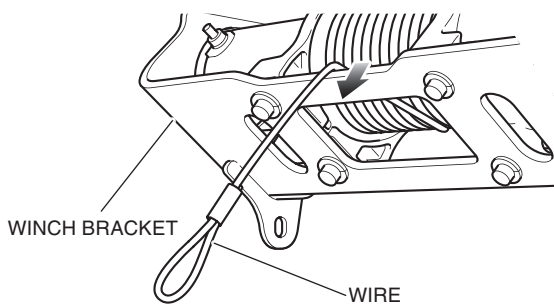

32. Loosely install the assembled winch as shown.

<Front side>

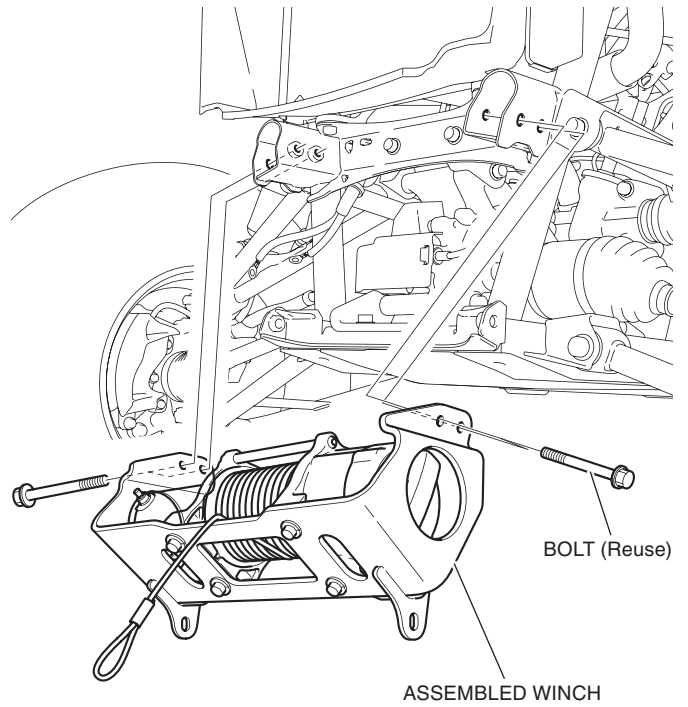

33. Install the winch power cables as shown.

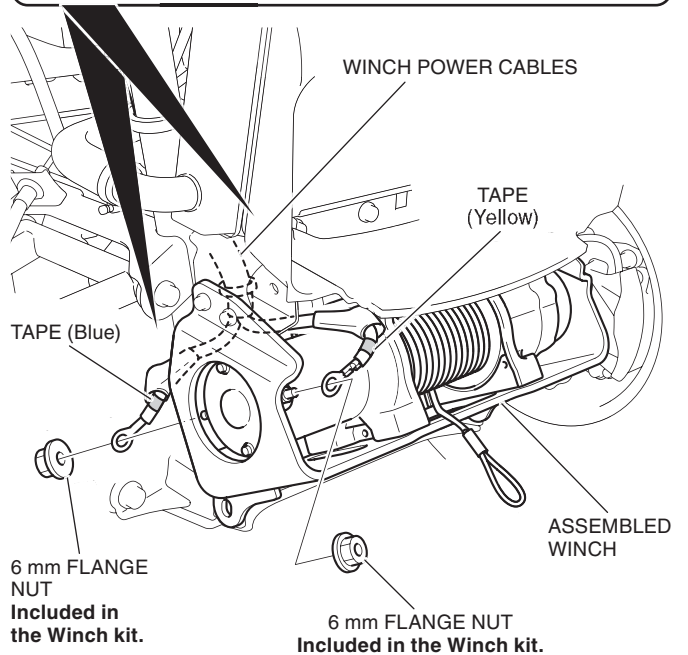
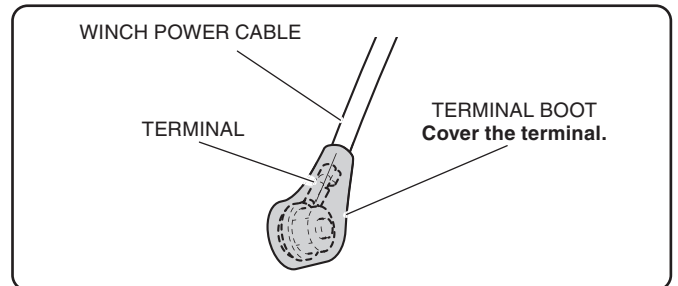

34. Remove the blue tape from the factory installed winch ground cable. Remove the indicated clip band from the front fender.

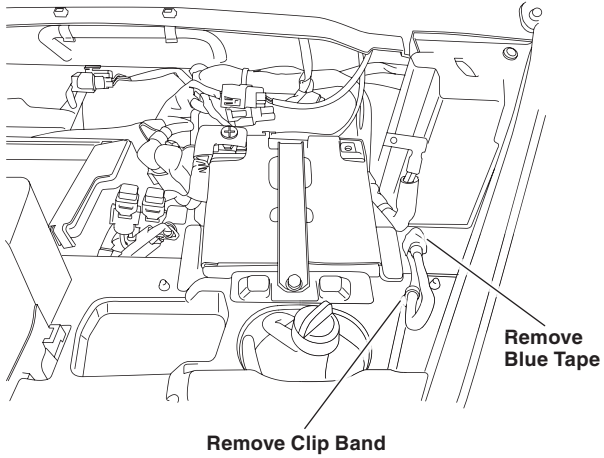

35. Route the winch power cables through the hole in the front fender as shown.

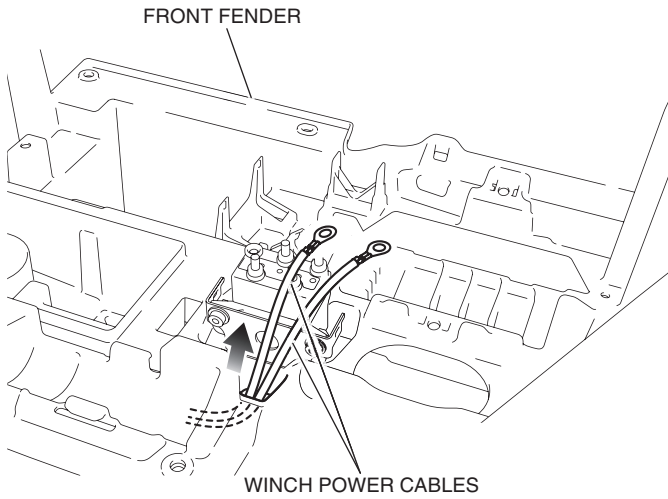

36. Route the winch sub harness along the main harness as shown.

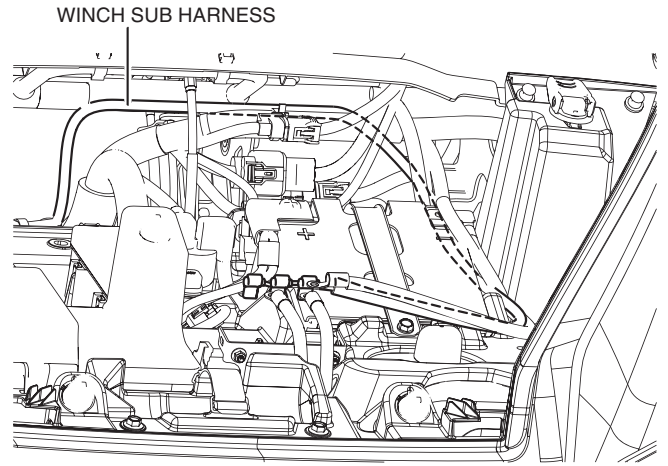

37. Connect the sub harness to the contactor as shown.

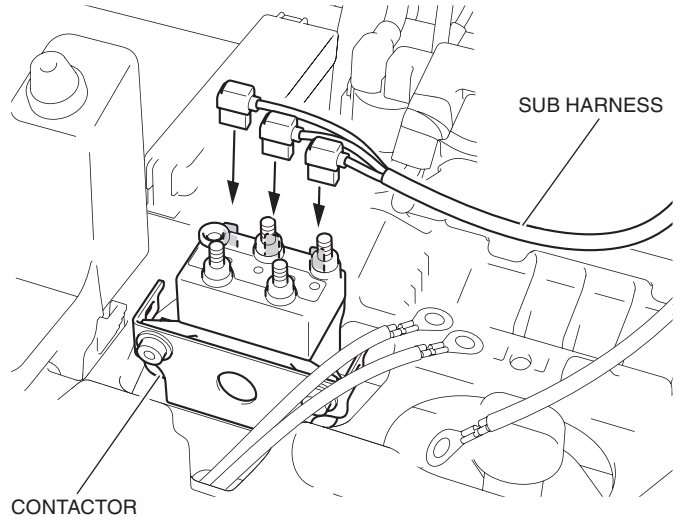

38. Install the terminal boots as shown.

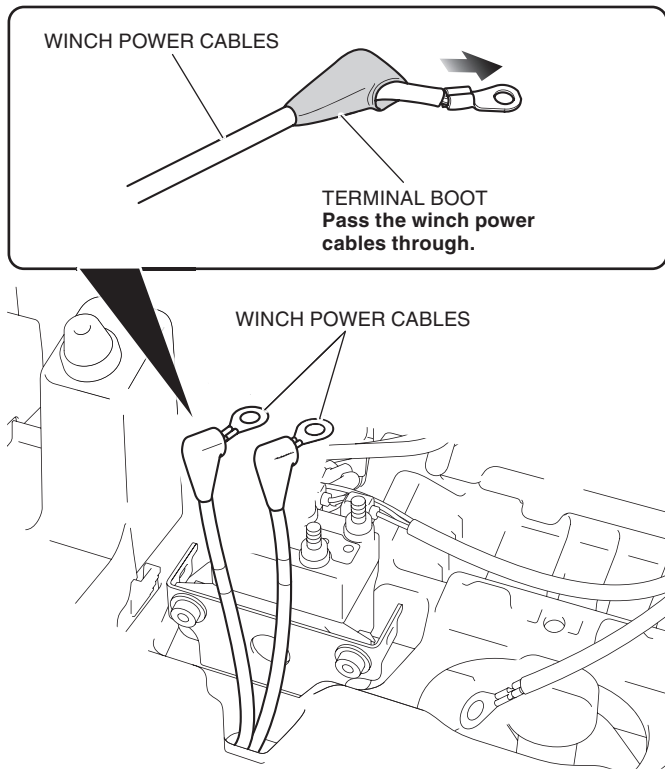

39. Install the winch power cables to the corresponding color terminal on the contactor as shown.

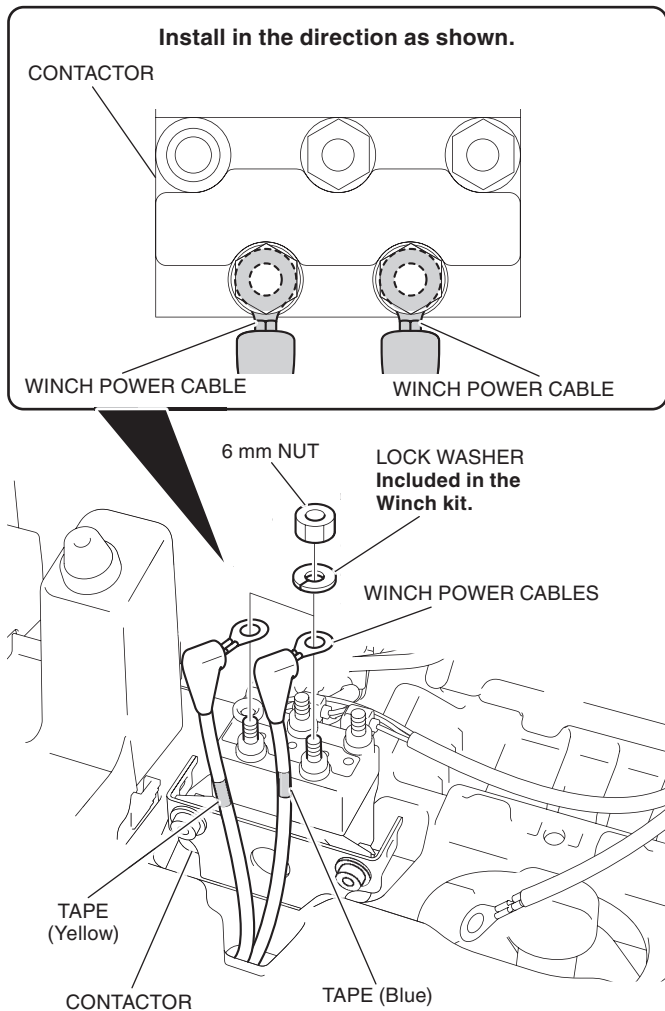

40. Remove the vehicle's harness from the starter relay switch as shown.

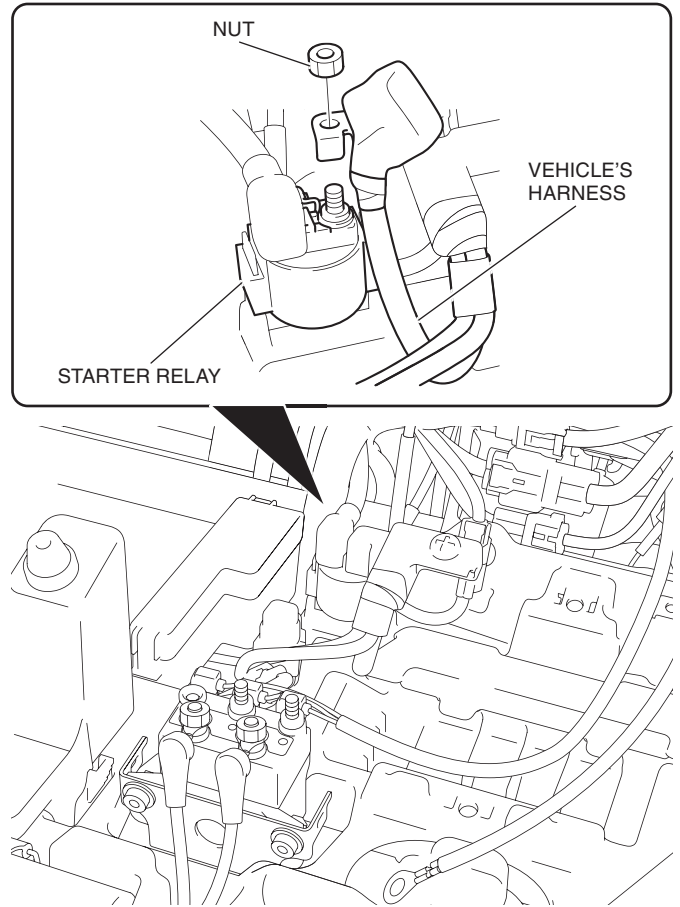

41. Cut the cover as shown.

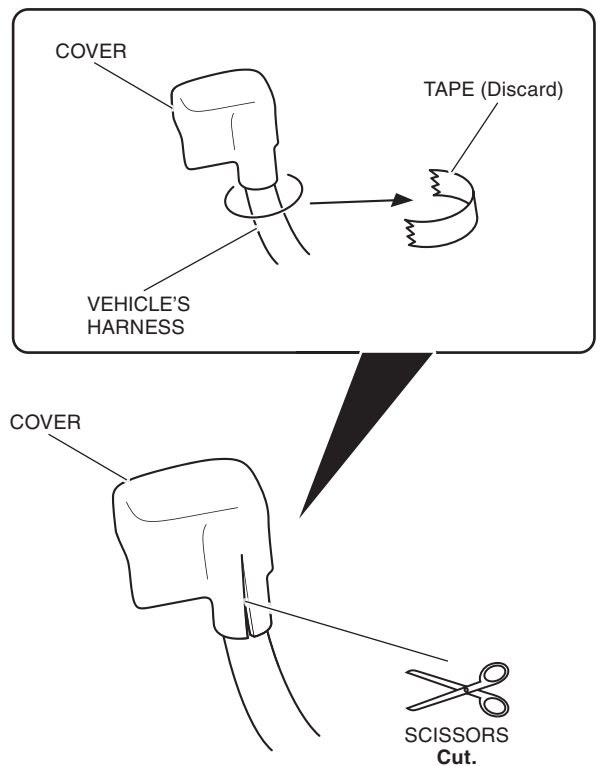

42. Remove the cover as shown.

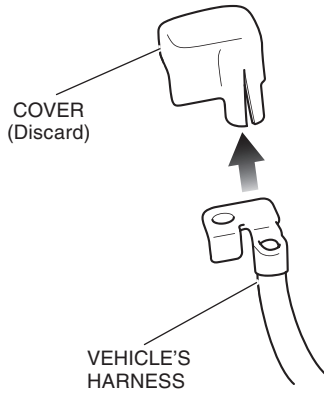

43. Connect the winch battery cable as shown.

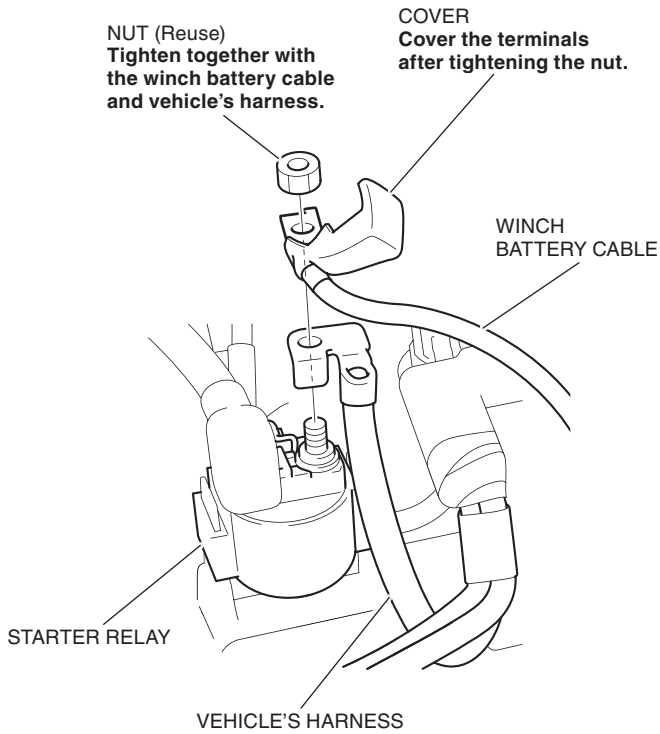

44. Install the terminal boot as shown.

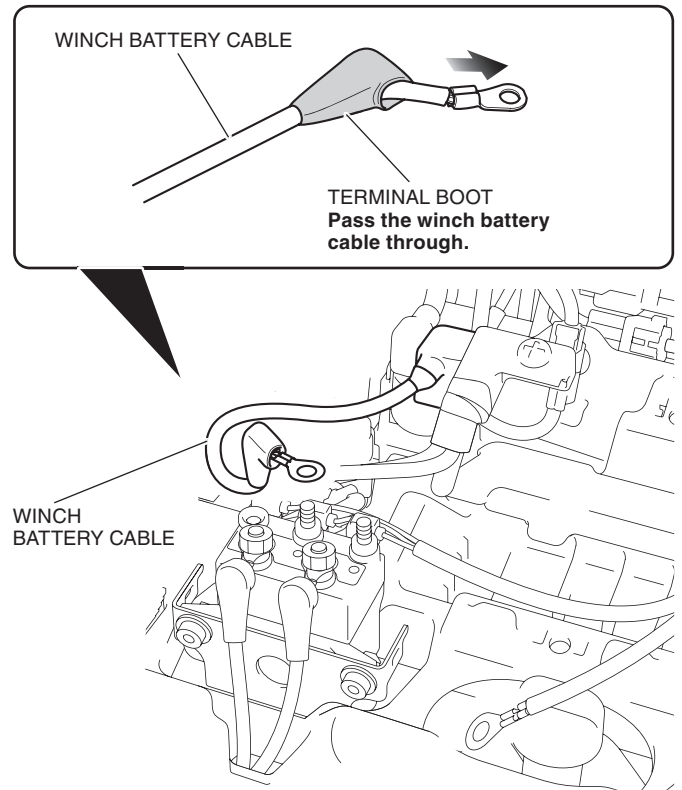

45. Install the winch battery cable as shown.

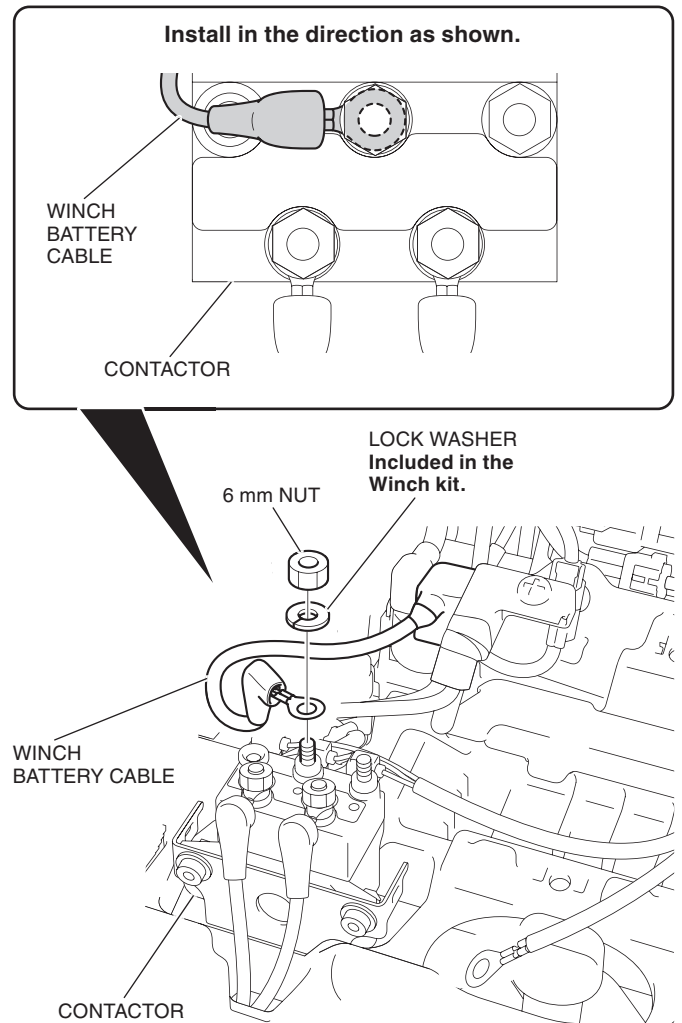

46. Install the terminal boot as shown.

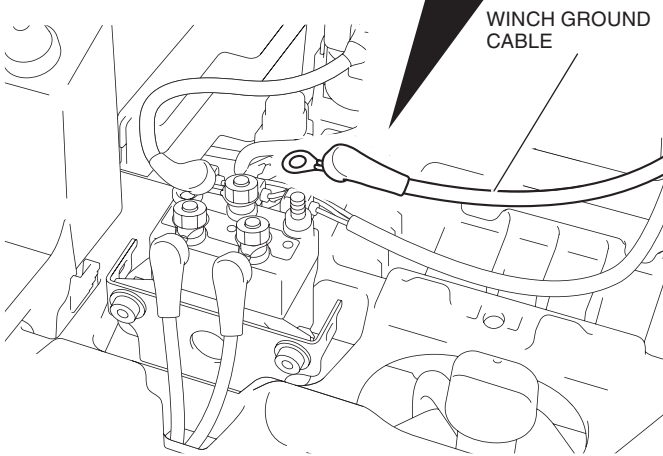
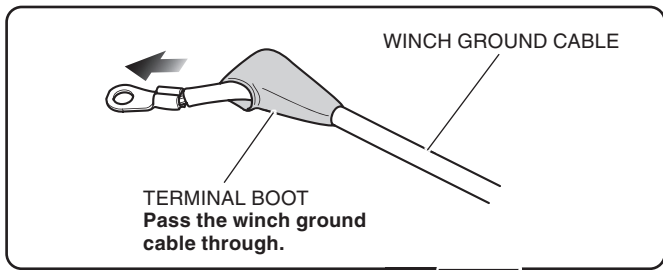

47. Install the winch ground cable as shown.

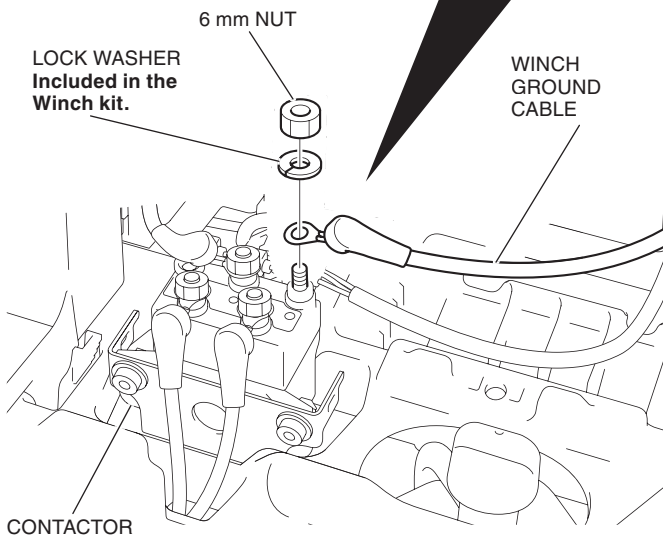
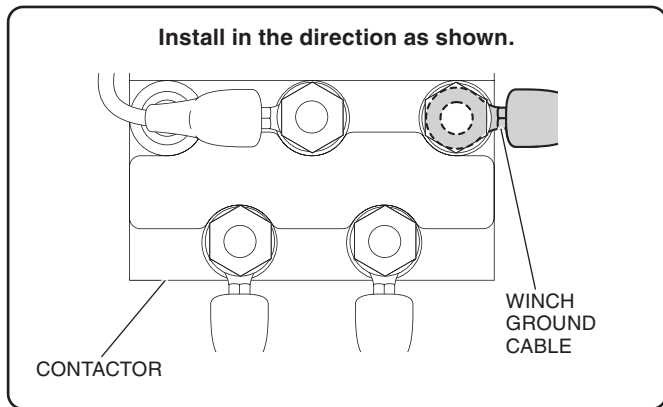

48. Cover each cable terminal with the terminal boot as shown.

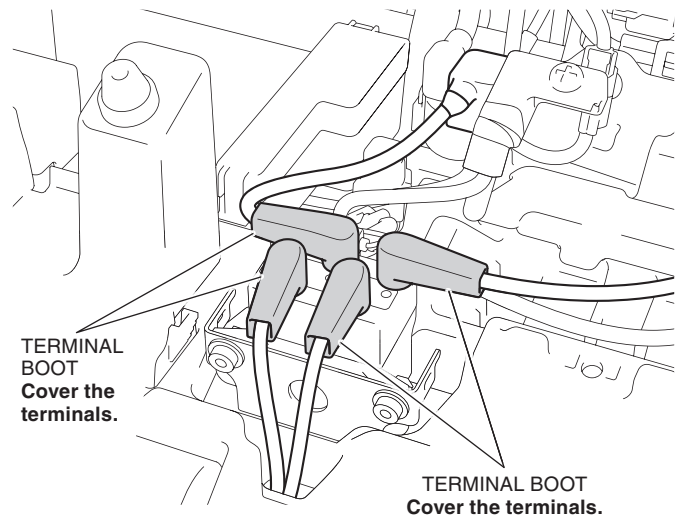

49. Install the contactor cover as shown.

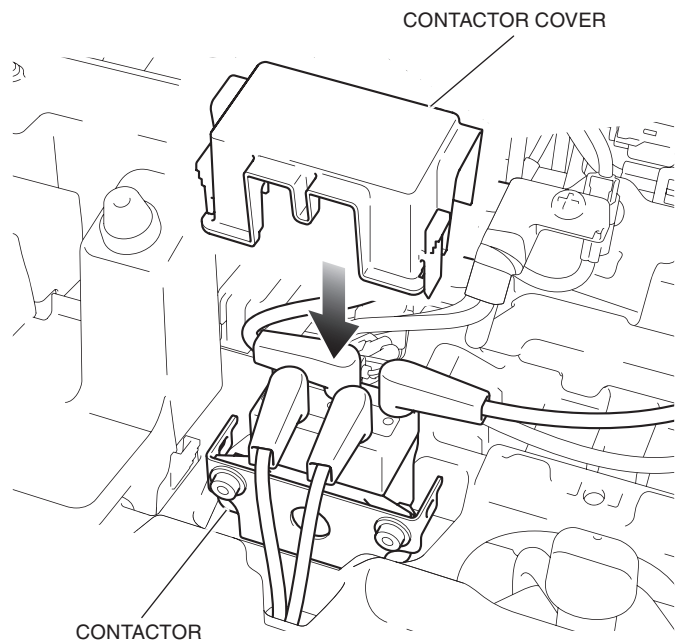

50. Install the clip band as shown, and secure it to the front fender.

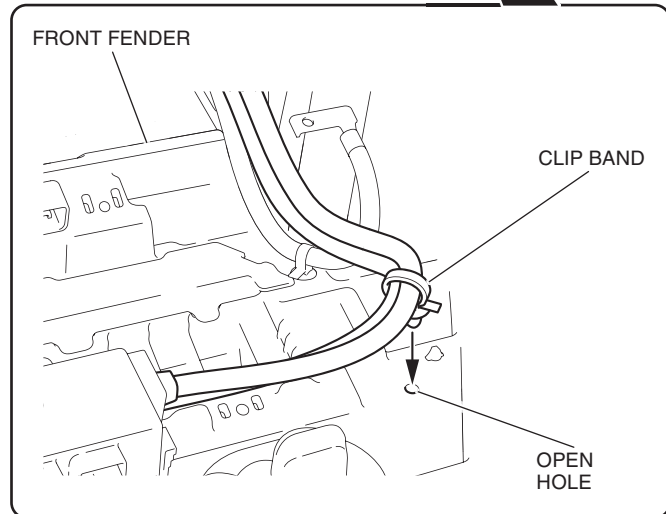
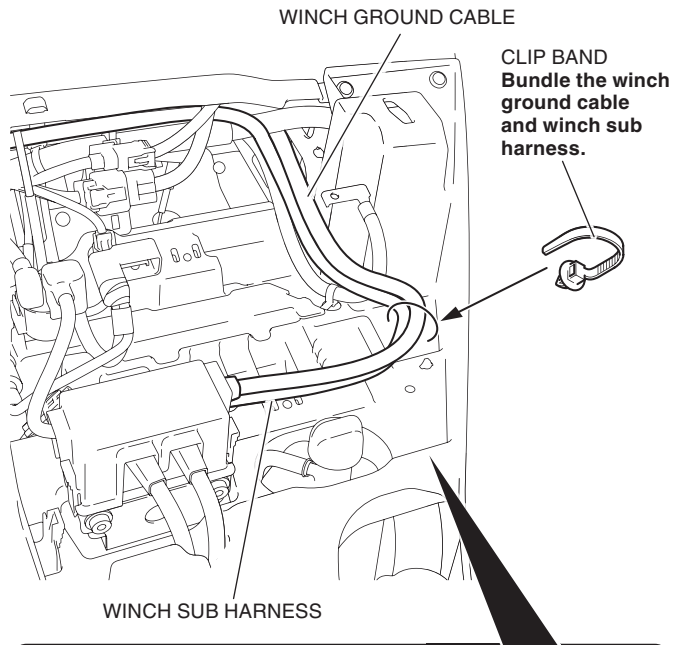

51. Secure the winch ground cable and sub harness with the wire tie as shown.

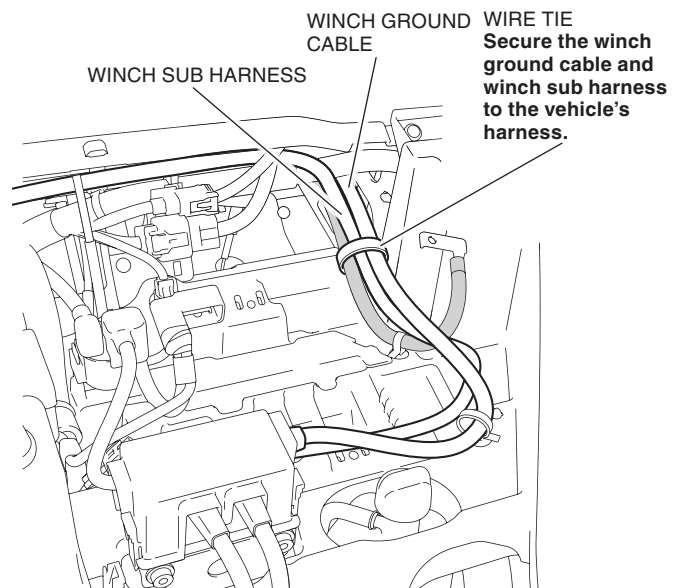

52. Secure the winch sub harness with the wire ties as shown.

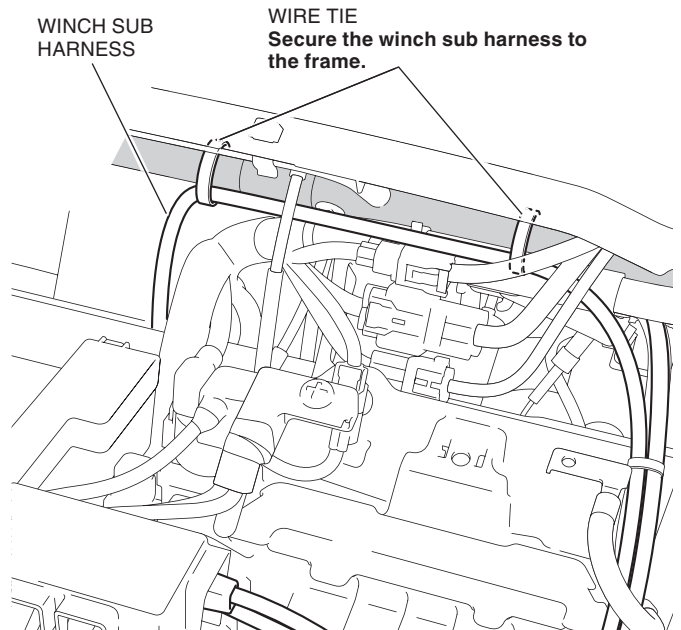

53. Temporarily install mechanic's wire or a wire tie as shown to secure the winch bracket to the A-arm.

<Left side>

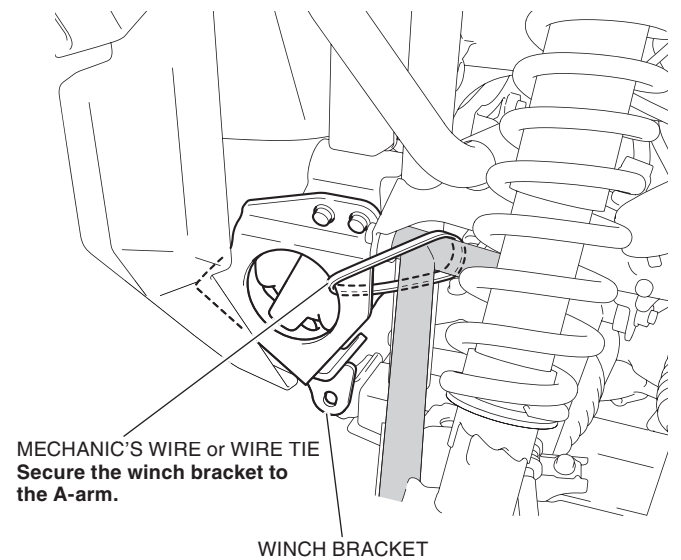

54. Remove the loosely installed bolts.

- Repeat on the right side.

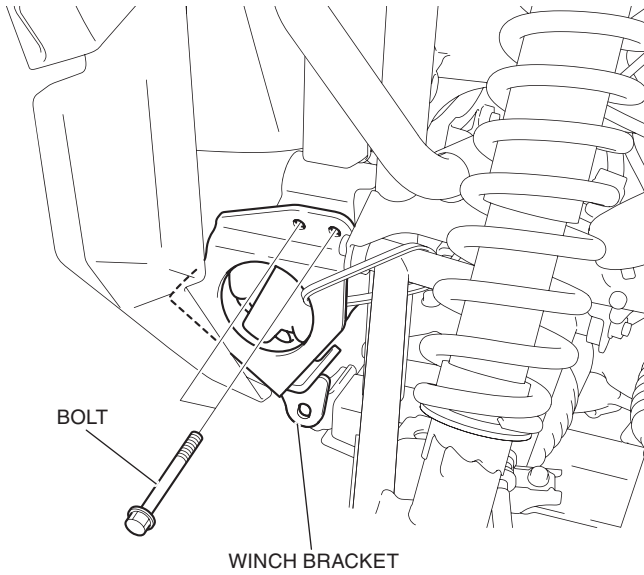

55. Install the front bumper and winch bracket as shown.

- Repeat on the right side.
- After installing winch bracket, remove the wire or wire tie.

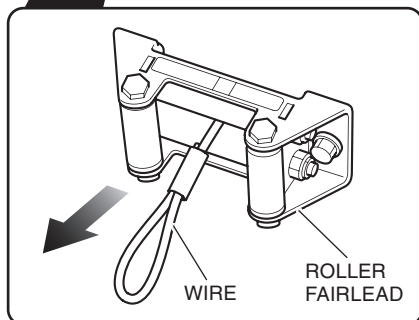
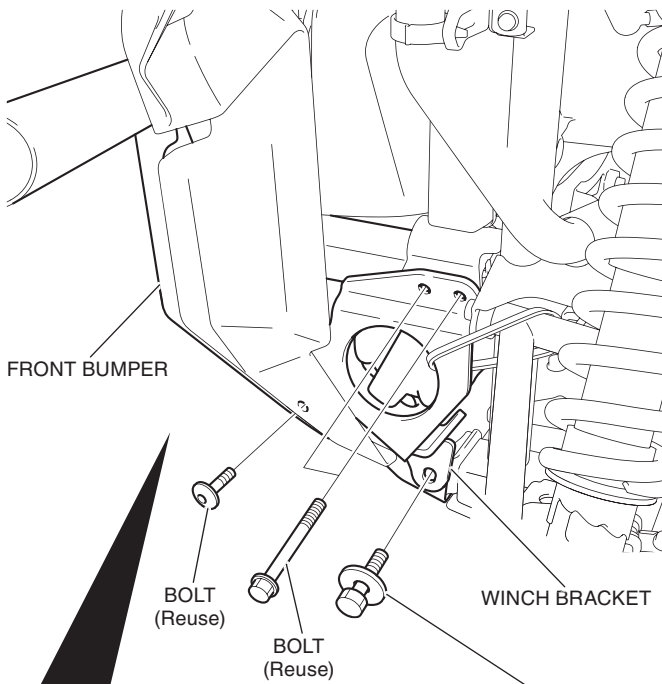

56. Install the hook and strap as shown.

<Front side>

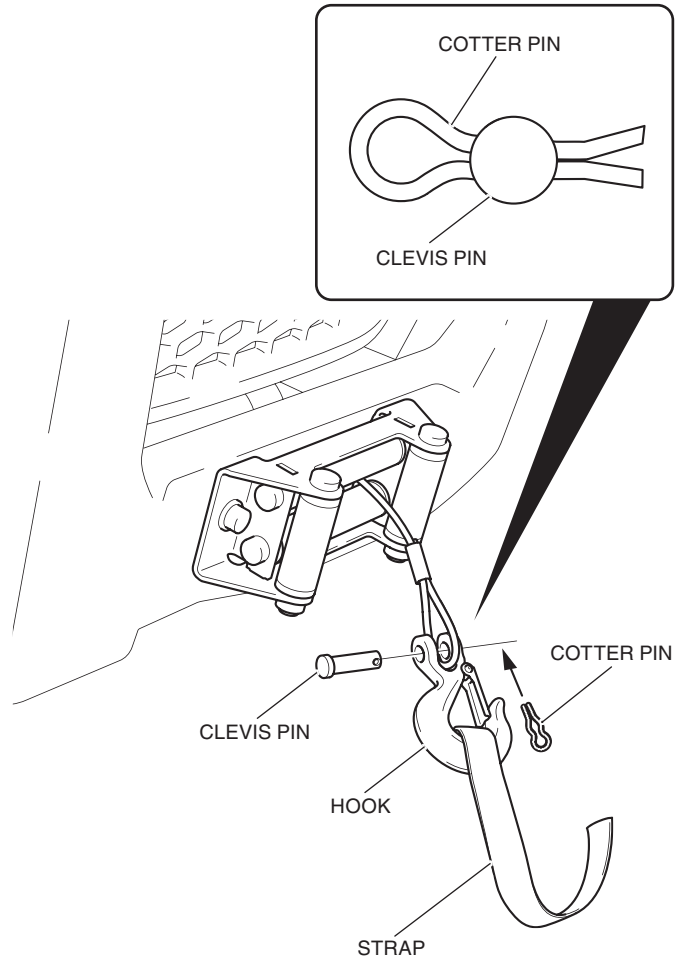

57. Connect the remote control switch as shown.

<Right side>

After connecting, put the remote control switch in the glove box as shown.

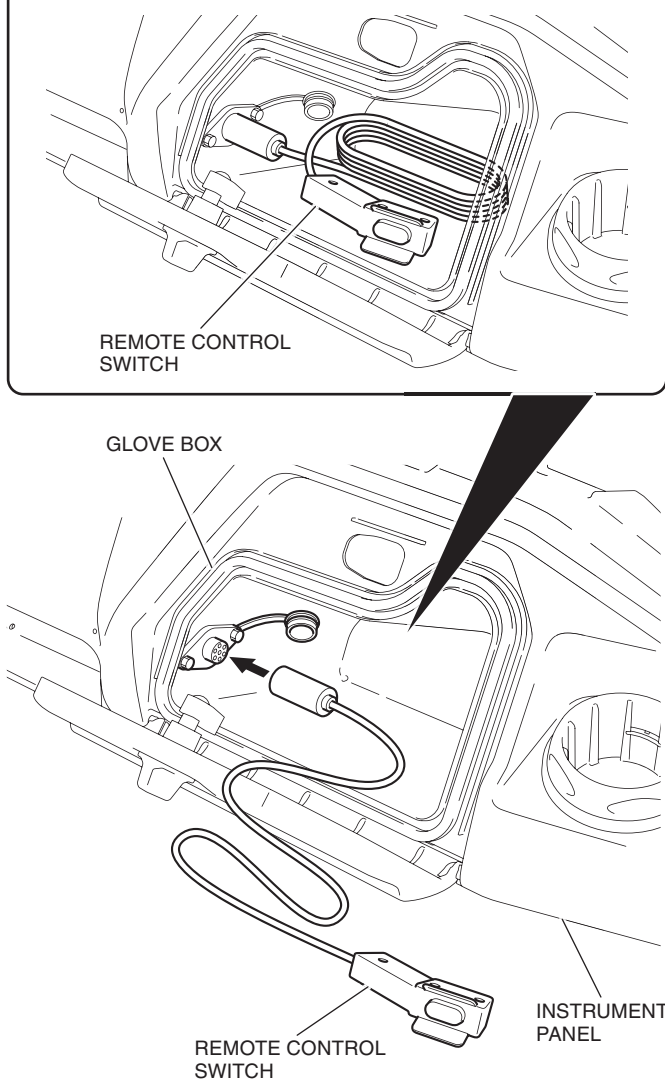

58. Confirm that wire harnesses are not caught or too tight.

59. Connect the battery negative (-) cable and check the function of all lights.

CHECK THE SYSTEM:

60. Before using the winch, verify the following:

- The wiring to all components is correct. All loose wires are secured tightly using wire-ties.
- There are no exposed wires or terminals. Cover any exposed wires or terminals with terminal boots, heat shrink tubing, or electrician's tape.
- Turn the vehicle ignition switch to the ON position.
- Check the winch for proper operation. The wire rope should spool in and out in the direction indicated on the switch.

