

Accessory	Application	Publication No.
REAR CARRIER A P/N 08L71-MGZ-A80ZA	CB500X/XA	MII 17166
		Issue Date
		May 2019

**Honda Dealer: Please give a copy of these instructions to your customer.**

## PARTS LIST

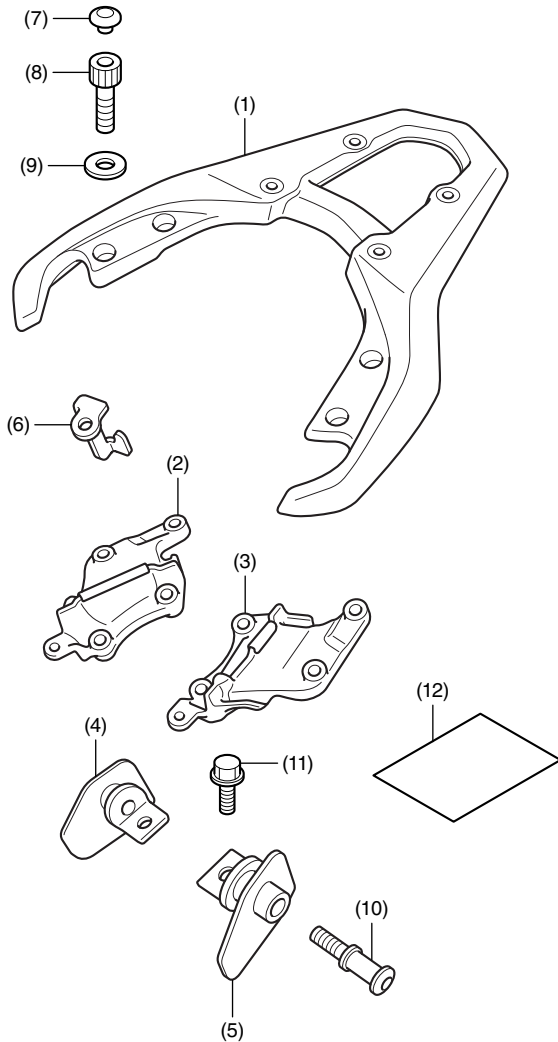

No.	Description	Qty
(1)	Rear carrier A	1
(2)	Right carrier stay	1
(3)	Left carrier stay	1
(4)	Right hook stay	1
(5)	Left hook stay	1
(6)	Helmet hook	1
(7)	Cap	4
(8)	8 mm socket bolt	4
(9)	Washer	4
(10)	8 mm hook bolt	2
(11)	6 mm flange bolt	2
(12)	Installation Instruction URL	1

## TOOLS REQUIRED

- Socket (10 mm)
- Ratchet
- Hex wrench (6 and 8 mm)
- Torque wrench

## TORQUE CHART

Tighten all screws, bolts, and nuts to their specified torque values. Refer to the Service Manual for the torque values of the removed parts.

Item	N-m	kgf-m	lbf-ft
6 mm flange bolt	12	1.2	9
8 mm socket bolt	22	2.2	16
8 mm hook bolt	22	2.2	16

## MAXIMUM LOADING CAPACITY

- The weight of the cargo must not exceed the following maximum loading capacity:

Maximum Loading Capacity	
Rear carrier A	6.6 lb (3.0 kg)

## INSTALLATION

### ▲ CAUTION

- To prevent burns, allow the engine, exhaust system, radiator, etc., to cool before installing the accessory.

- Remove the seat as shown.

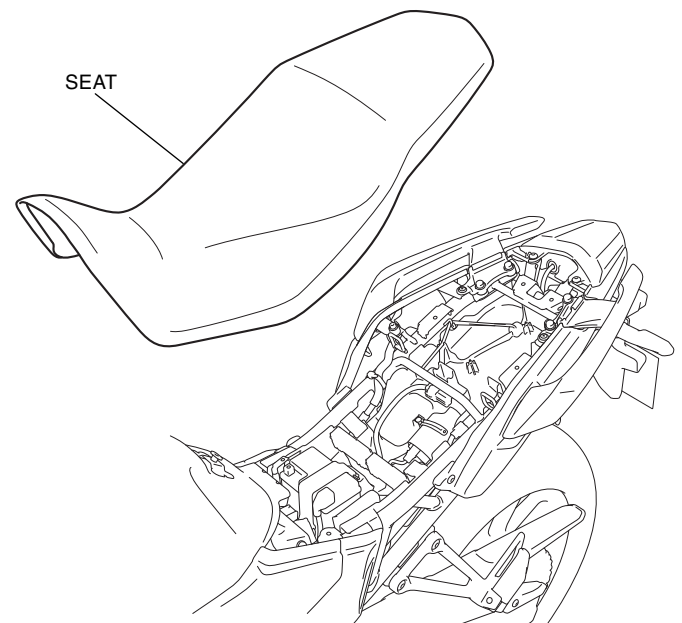

2. Remove the right and left grab rails as shown.

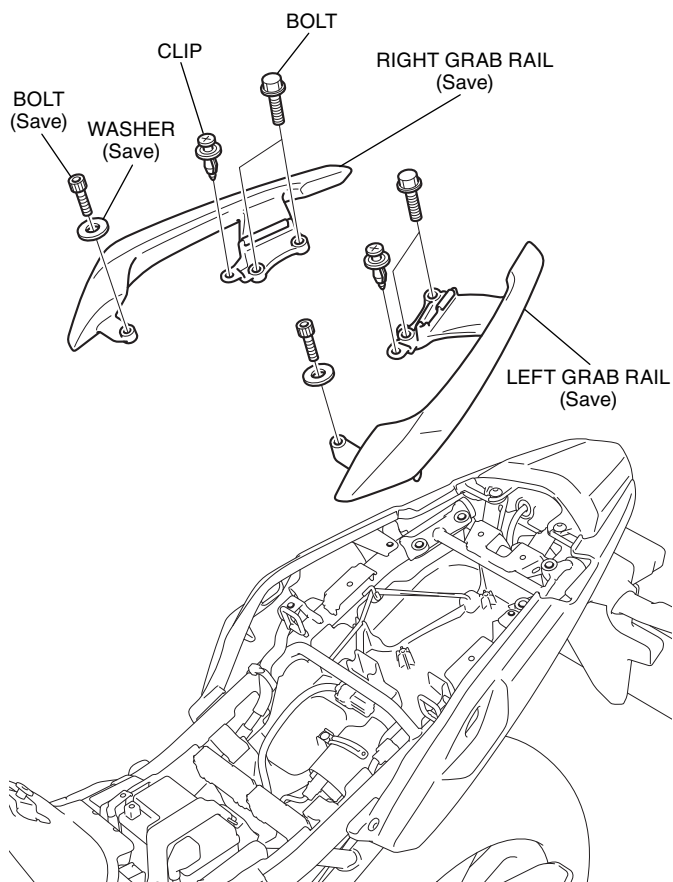

3. Install the left hook stay as shown.

- Repeat on the right side.

<Left side>

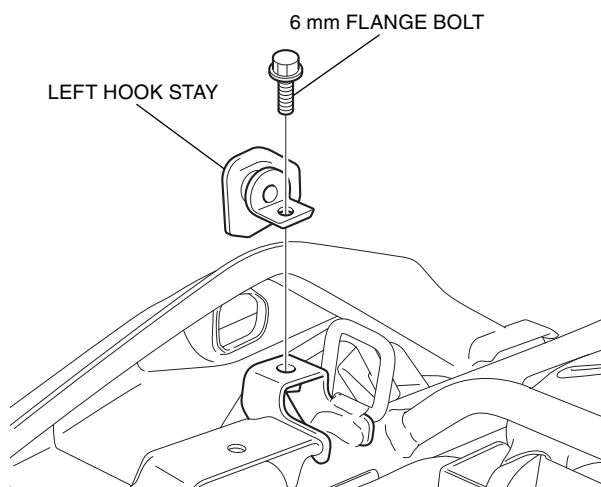

4. Install the 8 mm hook bolt as shown.

- Repeat on the right side.

<Left side>

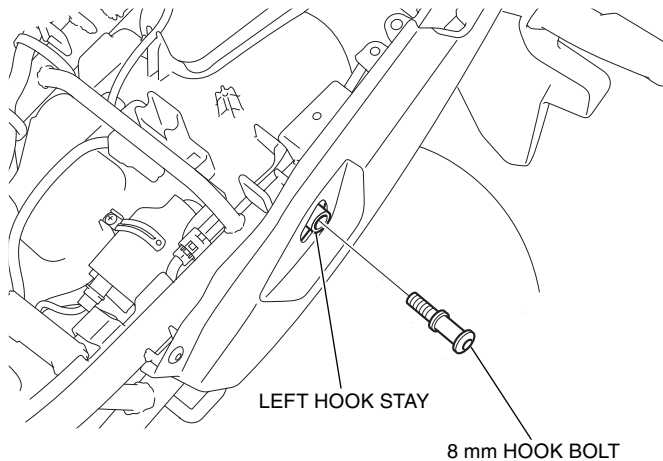

5. Loosely install the left carrier stay as shown.

- Repeat on the right side.

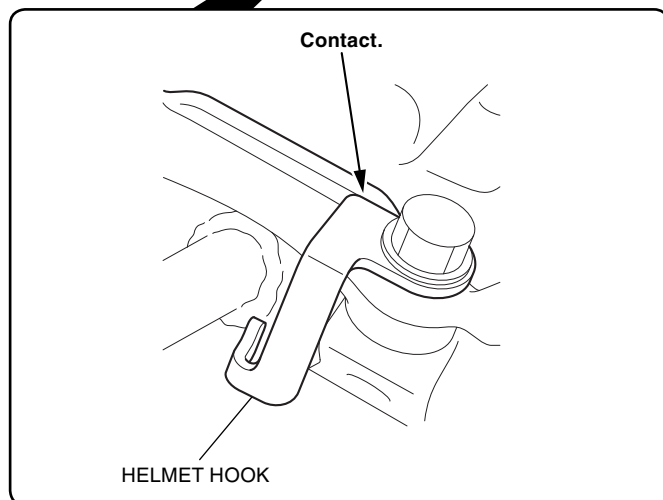
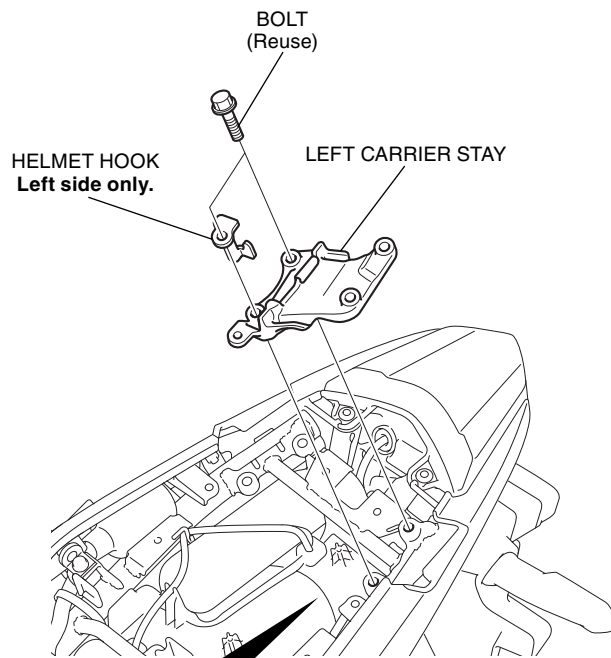

6. Install the clips as shown.

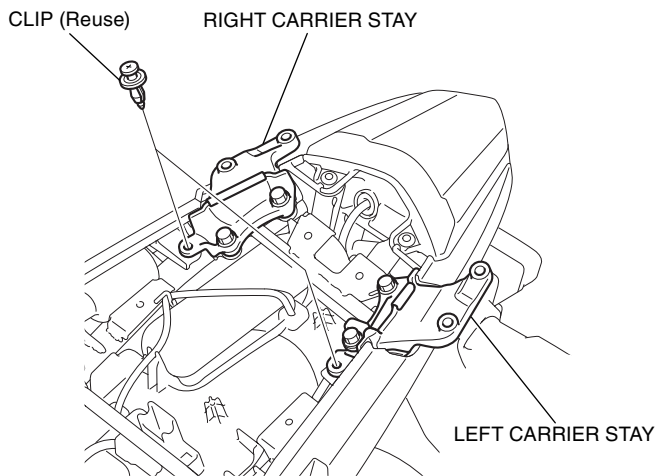

7. Install the rear carrier A as shown.

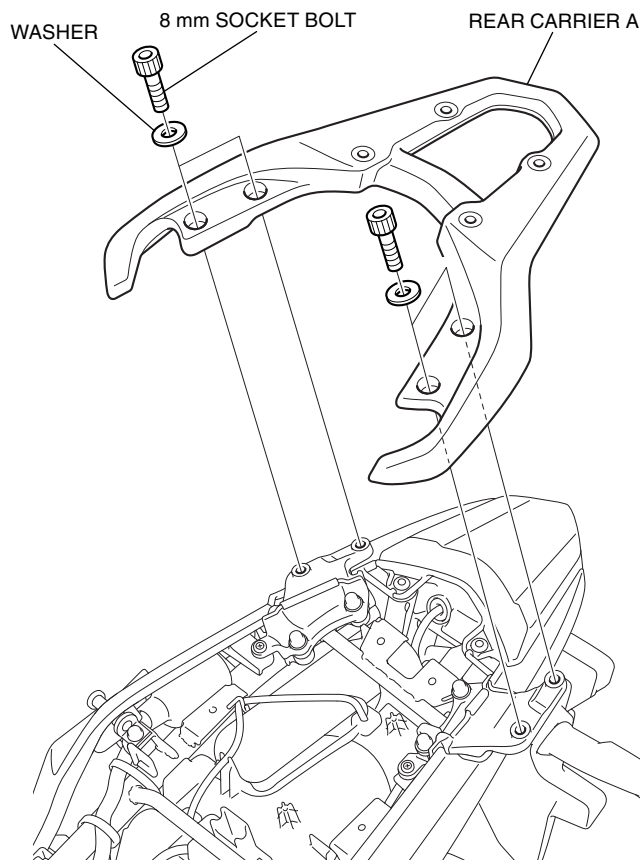

8. Securely tighten the bolts as shown.

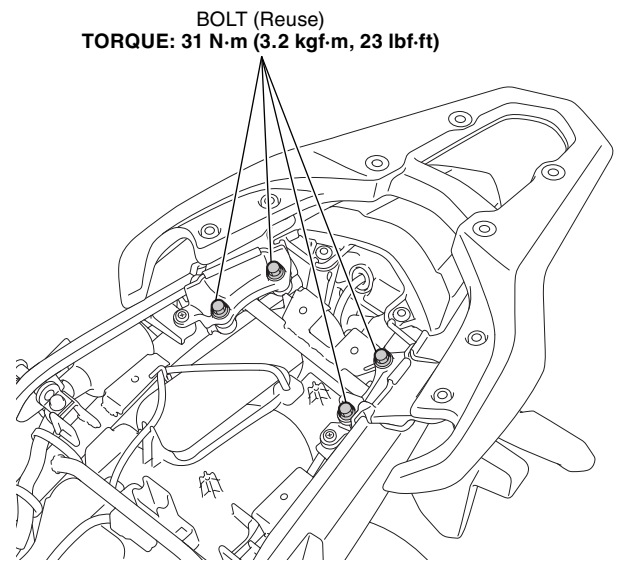

9. Install the caps as shown.

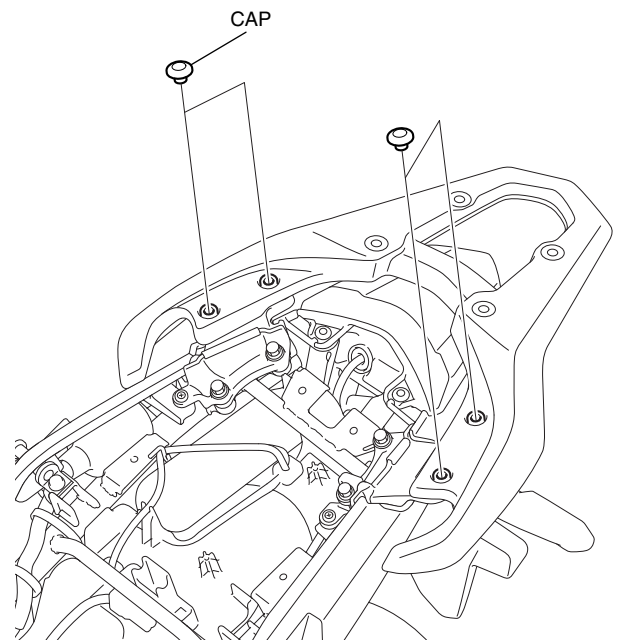

10. Install the motorcycle's parts in the reverse order of removal.