



INSTALLATION INSTRUCTIONS

Accessory

UNDER DASH STORAGE POCKET
P/N 08L71-HL4-F00

Application

SXS1000M3/M5/M6

Publication No.

MII 17762

Issue Date

Revised: August 2022

PARTS LIST

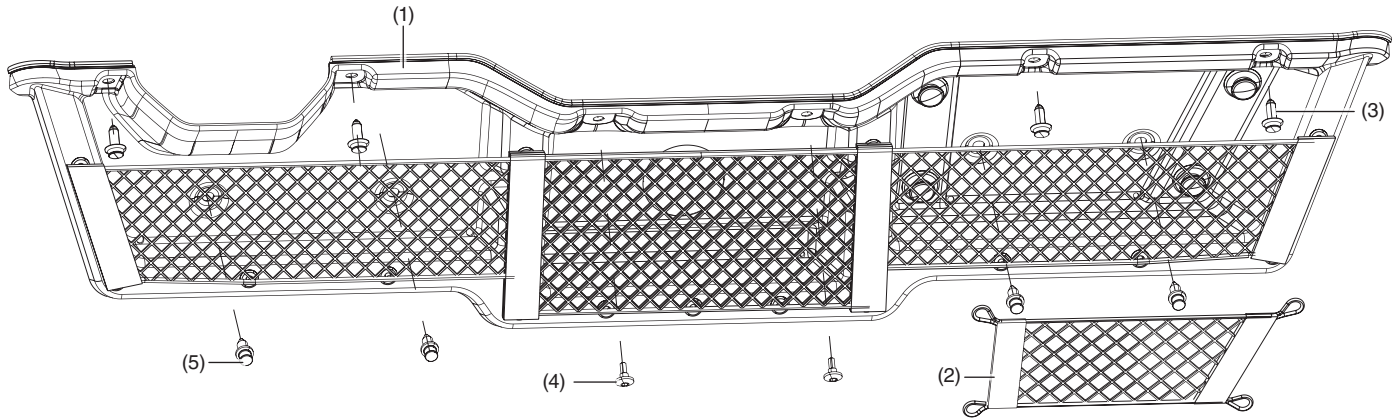

No.	Description	Qty
(1)	Under dash storage unit	1
(2)	Net, passenger side storage	1
(3)	Long trim clip	4
(4)	Pan screw, 5 x 16 mm	2
(5)	Short trim clip	4

TOOLS AND SUPPLIES REQUIRED

Hex wrench (4 mm)

Power drill

Drill bit (3/8 inch)

Marker

Torque wrench

TORQUE CHART

Tighten all screws, bolts, and nuts to their specified torque values. Refer to the Service Manual for the torque values of the removed parts.

Item	N·m	kgf·m	lbf·ft
5 mm screw	4	0.4	3

USE AND CARE INFORMATION

- Check the accessory mounts frequently and retighten if necessary.
- Replace this accessory with a new one if it is damaged or discolored excessively.
- To clean the under dash storage, empty the storage area, clean the interior with warm water and soap using a wet cloth or sponge, and rinse it thoroughly. Do not use a brush to clean this accessory as it may scratch the surface.
- Never use petroleum based solvents such as gasoline, thinner or benzene to clean this accessory. Also do not use acid or alkaline cleaners.

INSTALLATION

1. Remove and save the four trim clips and two pan screws from the lower area of the instrument panel as shown.

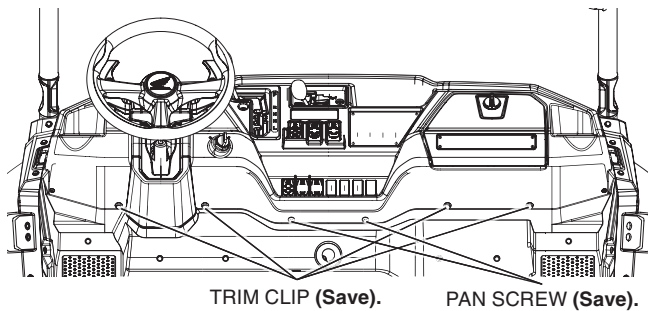

After '16 Model Year

2. Using the 3/8 inch drill bit, drill holes in the floor cover at the molded drill point as indicated below. After the holes are drilled, proceed to Step 7.

Wind the tape around the drill bit leaving 10 mm of the tip of the drill bit exposed to serve as a drill stop.

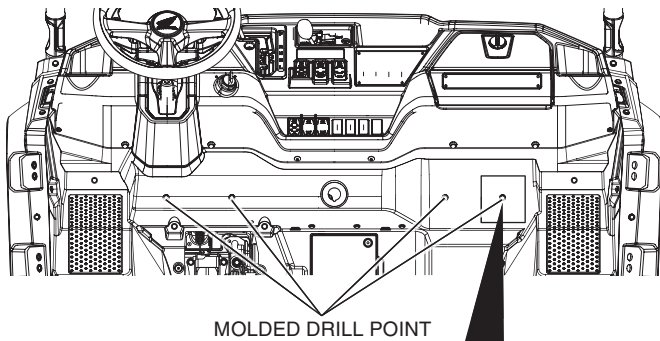
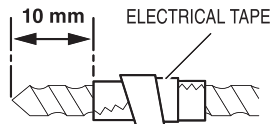

'16 Model Year Only

3. Temporarily install the under dash storage unit assembly on to the instrument panel and secure the center and upper corners as shown using:
 - a. (2) Pan screw, 5 x 16 mm
 - b. (2) Long trim clipDo not set the long trim clip at this time.

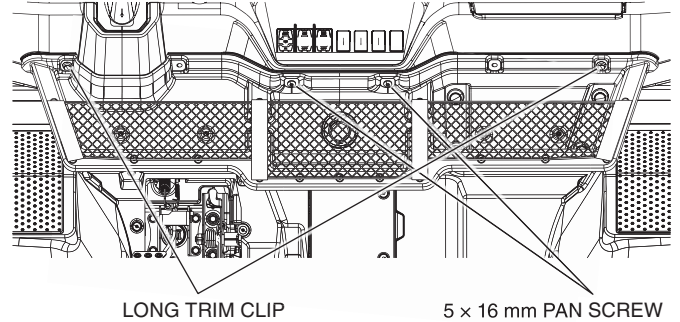

4. Apply upward pressure to hold storage unit assembly firmly against the floor cover panel. Use the holes shown as a template to mark the position of four holes to be drilled in the floor cover.

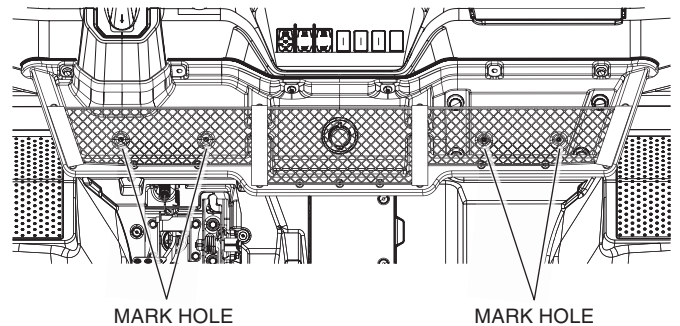

5. Remove the under dash storage unit that was temporarily installed in Step 3.
6. Using the 3/8 inch drill bit, drill holes in the floor cover at the positions marked in Step 4.

Wind the tape around the drill bit leaving 10 mm of the tip of the drill bit exposed to serve as a drill stop.

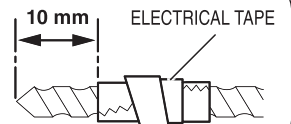

All Years

- 7. Install, but do not tighten the center fasteners through the under dash storage as shown using the 5 × 16 mm pan screws.

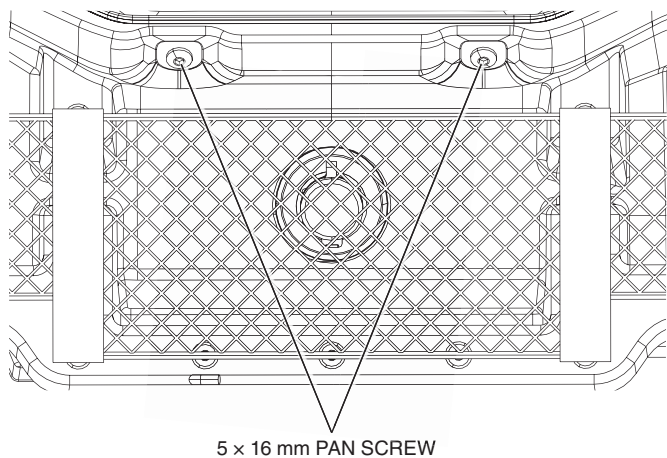

- 8. Install long trim clip at the four locations shown.

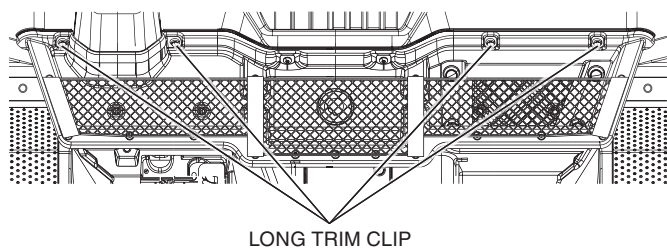

- 9. Install a short trim clip in each of the four previously drilled holes at the locations shown.

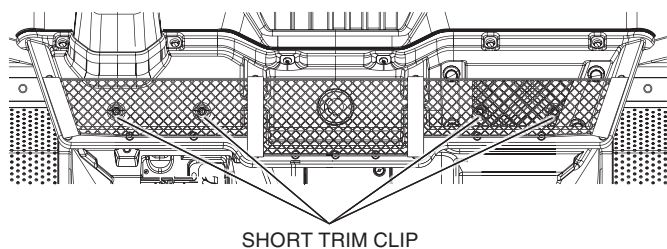

- 10. Install the passenger side storage net to the trim clips as shown.

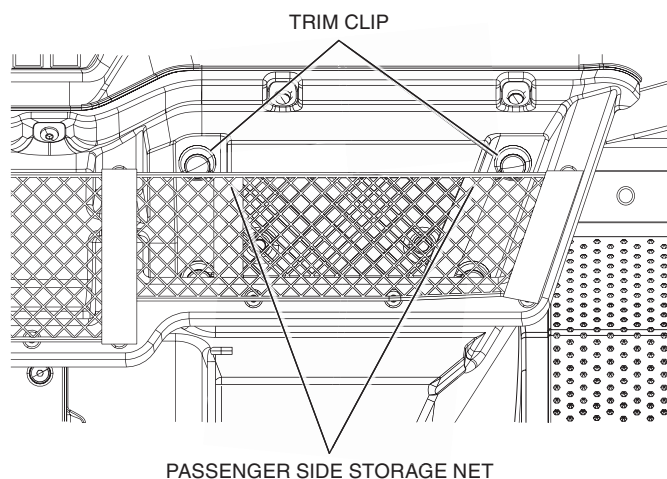

- 11. Tighten the hardware to the specification in the Torque Chart.