



# INSTALLATION INSTRUCTIONS

Accessory

FRONT FORK COVER  
P/N 08F71-K87-A30

Application  
After '19  
CMX300/A  
CMX500/A

Publication No.

MII 17465

Issue Date

March 2020

**Honda Dealer: Please give a copy of these instructions to your customer.**

## PARTS LIST

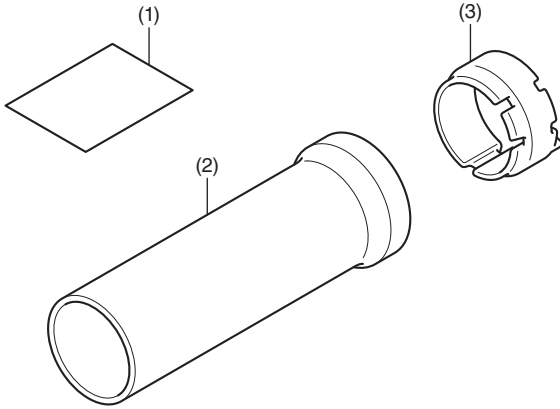

No.	Description	Qty
(1)	URL paper	1
(2)	Front fork cover	2
(3)	Rubber collar	2

### Sold separately



No.	Description	Qty
(1)	Brake caliper bolt (8 mm flange bolt) [90131-KZZ-900]	2
(2)	Front fender bolt (6 mm socket bolt) [90130-K87-A00]	4

## TOOLS REQUIRED

Socket (12 mm)  
Ratchet  
Hex wrench (5 mm)  
Torque wrench

## TORQUE INFORMATION

Refer to the Service Manual for the torque values of the removed parts.

## INSTALLATION

### NOTE:

- Take care not to damage the painted surfaces of the motorcycle.

- Refer to the Service Manual for the motorcycle, remove the motorcycle parts.
  - Do not suspend the brake caliper assembly from the brake hose.**

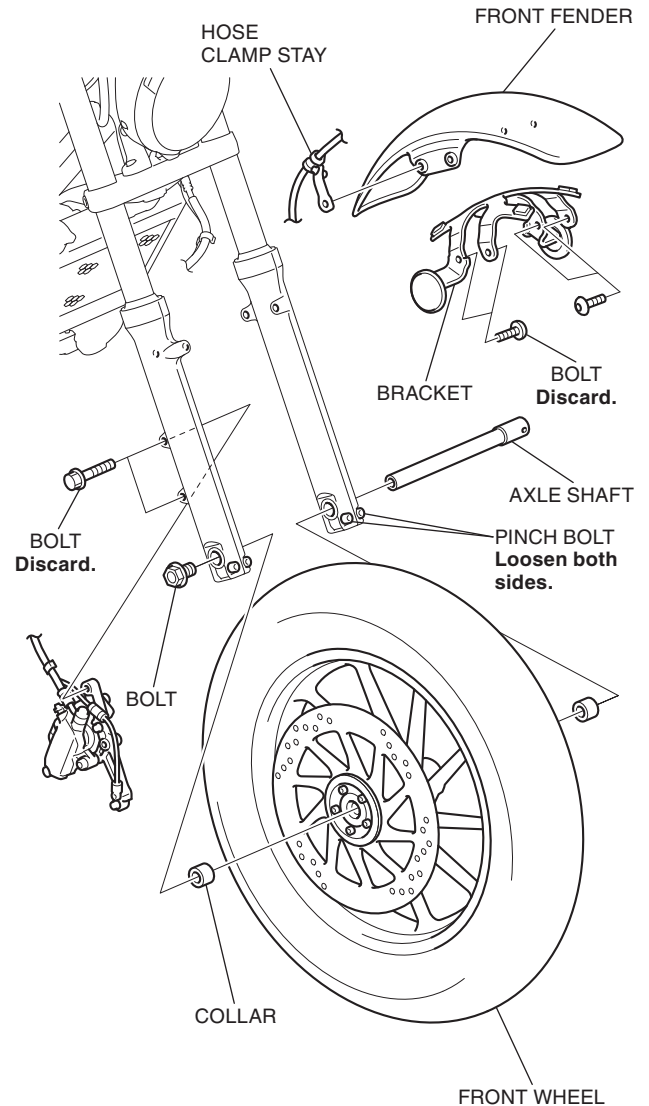

2. Refer to the Service Manual for the motorcycle, remove the motorcycle parts.
  - **Repeat on the left side.**

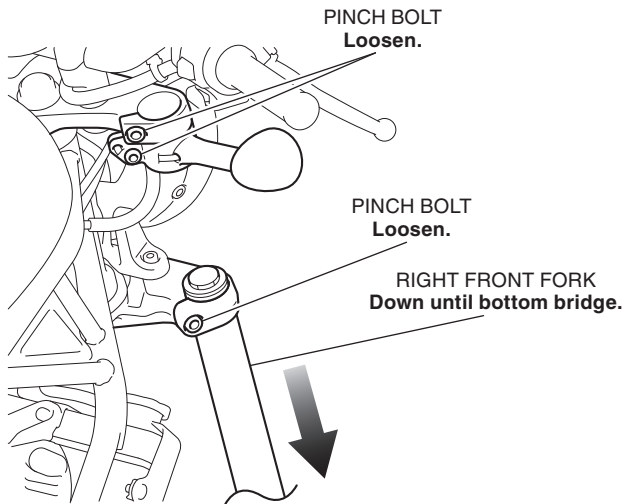

3. Temporarily tighten the bottom bridge pinch bolt and install the front fork cover as shown.
  - **Repeat on the left side.**

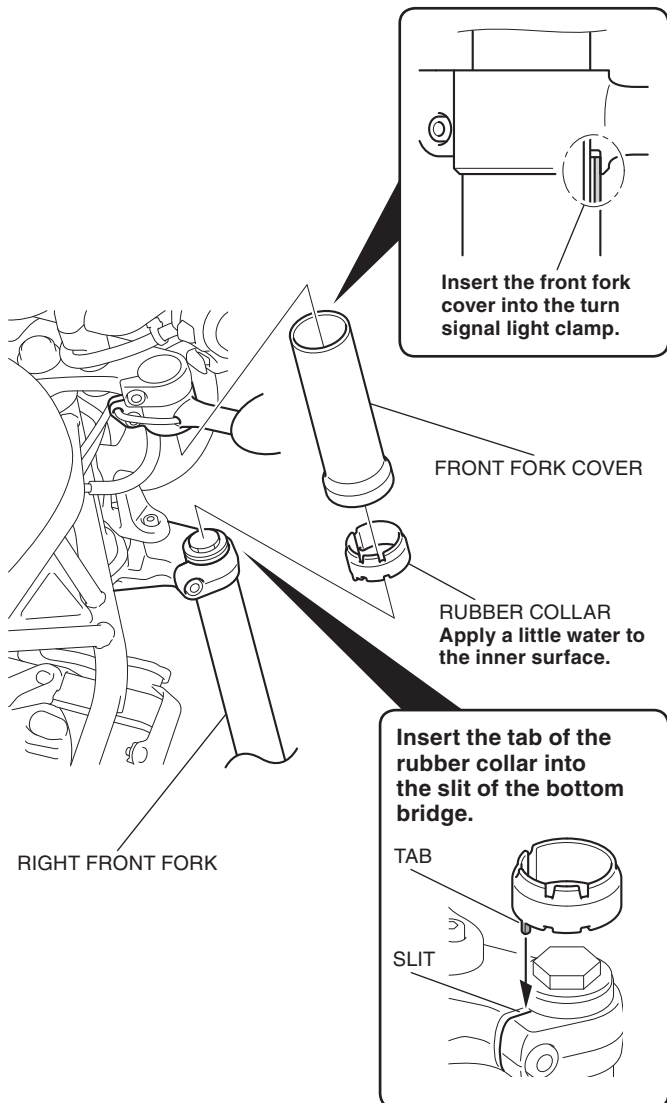

4. Install the removed parts in the reverse order of removal and tighten the loosely installed hardware.
  - **Replace the brake caliper bolts and front fender bolts with new ones.**