



INSTALLATION INSTRUCTIONS

Accessory

FRONT FORK BOOT
P/N 08F70-K87-A30

Application

After '19
CMX300/A
CMX500/A

Publication No.

MII 17465

Issue Date

March 2020

Honda Dealer: Please give a copy of these instructions to your customer.

PARTS LIST

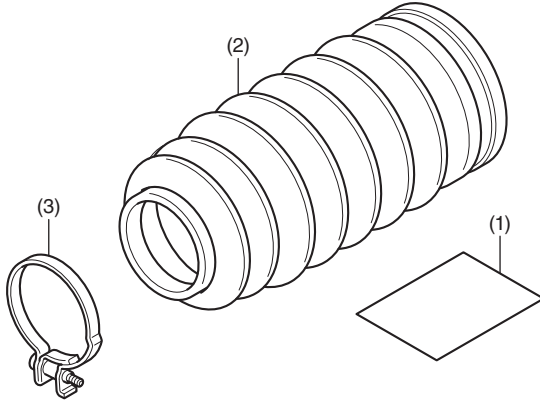

No.	Description	Qty
(1)	URL paper	1
(2)	Front fork boot	2
(3)	Band	2

Sold separately



No.	Description	Qty
(1)	Brake caliper bolt (8 mm flange bolt) [90131-KZZ-900]	2
(2)	Front fender bolt (6 mm socket bolt) [90130-K87-A00]	4

TOOLS REQUIRED

Socket (12 mm)
Ratchet
Hex wrench (5 mm)
Phillips® screwdriver
Torque wrench

TORQUE INFORMATION

Refer to the Service Manual for the torque values of the removed parts.

INSTALLATION

NOTE:

- Take care not to damage the painted surfaces of the motorcycle.

- Refer to the Service Manual for the motorcycle, remove the motorcycle parts.
 - Do not suspend the brake caliper assembly from the brake hose.**

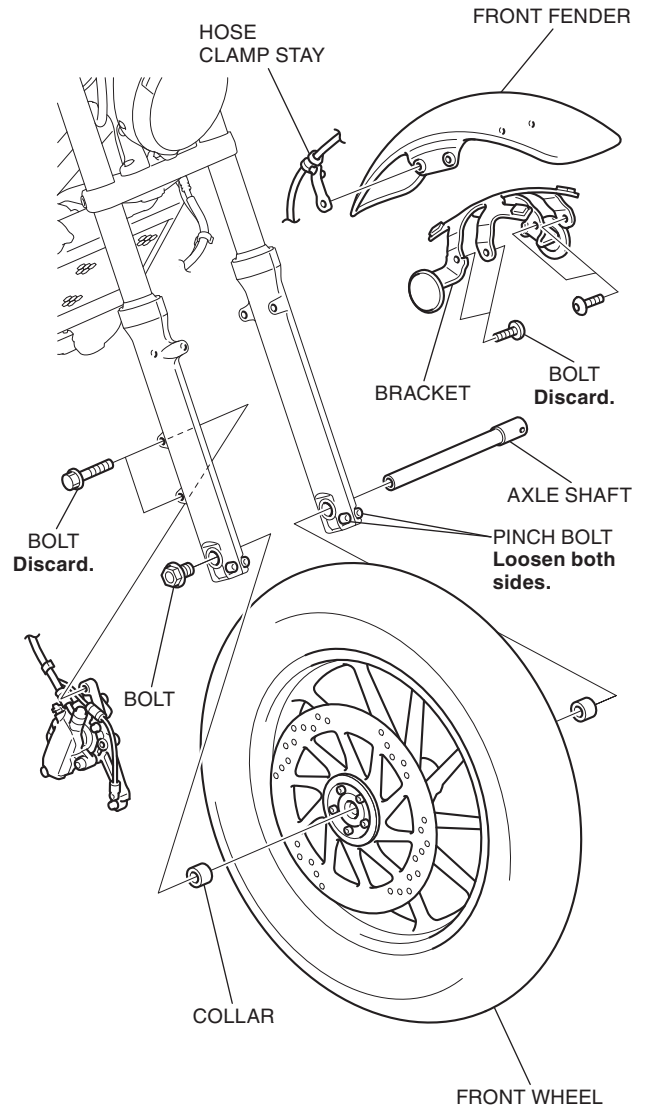

2. Refer to the Service Manual for the motorcycle, remove the motorcycle parts.
 - **Repeat on the left side.**

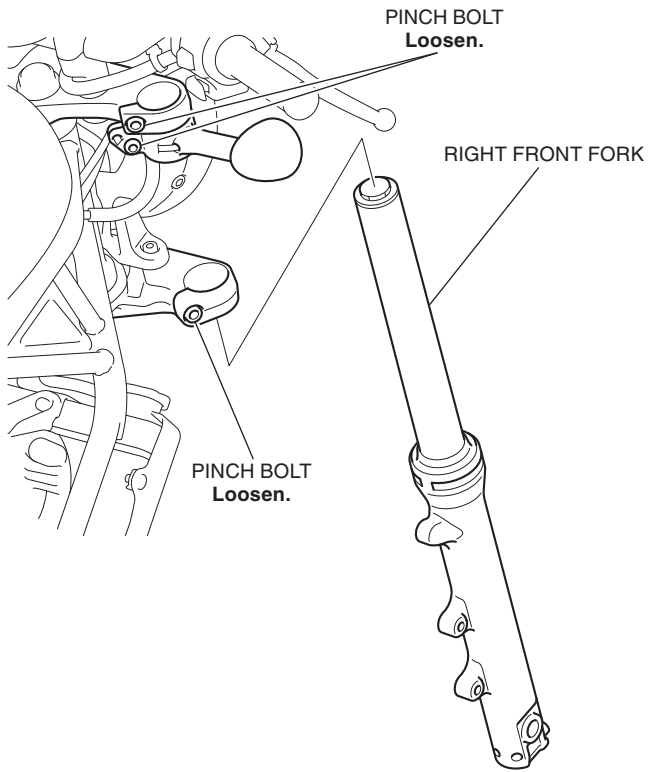

4. Install the removed parts in the reverse order of removal and tighten the loosely installed hardware.
 - **Replace the brake caliper bolts and front fender bolts with new ones.**
 - **Tighten the band screw firmly until the collar is fully seated.**

3. Loosely install the front fork boot as shown.
 - **Repeat on the left side.**

